



USER'S MANUAL

M-GV4 Piccolo

High-efficiency 4kW Genverter for marine use



Art.no. 40200821

WHISPERPOWER BV
Kelvinlaan 82
9207 JB Drachten
Netherlands
Tel.: +31-512-571550
Fax.: +31-512-571599
www.whisperpower.com

V1.1 June 2015

Contents

1	INTRODUCTION	4
1.1	General	4
1.2	Service and maintenance	4
1.3	Guarantee.....	4
1.4	Liability	4
1.5	Identification	4
1.5.2	Identification plate.....	4
2	INFORMATION.....	4
2.1	Safety.....	4
2.1.1	Warnings and symbols.....	4
2.1.2	General	5
2.1.3	Organizational measures	5
2.1.4	Maintenance & repair.....	5
2.1.5	Electrical safety.....	5
2.1.8	Operation.....	5
2.1.9	Fire and explosion.....	6
2.1.10	Chemicals.....	6
2.2	Transport, lifting and storage	6
2.3	Features.....	6
2.3.1	General	6
2.3.2	Construction	6
2.3.3	Control	6
2.3.5	Documentation	6
3	TECHNICAL INFORMATION	7
3.1	Parts and relevant functions.....	7
3.1.1	Engine	7
3.1.2	AC Permanent Magnet Alternator	7
3.1.3	Control	7
3.1.4	Power Module Genverter	8
3.1.6	Battery charger	8
3.1.7	Load indicators.....	8
3.1.8	Fuel	8
3.1.9	Lubricating oil	8
3.1.10	Oil cooling heat exchanger	9
3.2	Technical data	10
3.2.1	General	10
3.2.2	Fuel specifications.....	12
3.2.3	Lubricating oil specifications.....	12
3.2.4	Electrical diagrams.....	12
4	OPERATION	13
4.1	General	13
4.2	Variable speed mode.....	13
4.3	Operating instructions.....	13
4.3.1	Summarized operating instructions (daily use)	13
4.3.2	Extended operating instructions.....	14
5	MAINTENANCE	16
5.1	Maintenance intervals.....	16
5.2	Alternator	16
5.3	Engine.....	16
5.3.1	Preliminary instructions.....	16
5.3.2	Bleeding fuel lines.....	16
5.3.3	Valve clearance	16
5.3.4	Replacing fuel filter	16
5.3.5	Cleaning oil strainer	16
5.3.6	Air filter element.....	17
5.4	Regular maintenance.....	17
5.4.1	Changing oil and cleaning the oil strainer.....	17
5.4.2	Checking the battery.....	17



- 5.4.3 Draining water from the fuel tank 17
- 5.4.4 Replacing the coolant pump impeller 17
- 5.4.5 Replacing the fuel filter..... 17
- 5.4.6 Air filter element..... 17
- 5.4.7 Checking hoses and electrical connections..... 17
- 5.4.8 Retightening cylinder head bolts and adjusting valve clearance 17
- 5.5 Putting out of service 18
- 6 TROUBLESHOOTING 19**
 - 6.1 General 19
 - 6.2 Alternator/ electrical faults 19
 - 6.2.1 Troubleshooting table for alternator 19
 - 6.3 Engine faults 19
 - 6.3.1 General 19
 - 6.3.2 Troubleshooting table for engine 19
 - 6.4 Raw water pump 23
 - 6.5 Warnings 23
 - 6.6 Service address..... 23
- 7 SPARE PARTS LIST 24**
- 8 MAINTENANCE LOG..... 25**

EC Declaration of Conformity

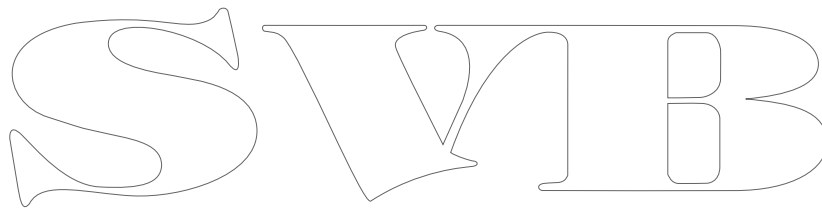

1 INTRODUCTION

1.1 General

This manual serves as a guideline for the safe and effective operation, maintenance and possible correction of minor malfunctions of the M-GV4 Piccolo manufactured and marketed by WhisperPower.

It is therefore obligatory that every person who works on or with the W-GV4 Piccolo must be completely familiar with the contents of this manual, and that he/she carefully follows the instructions contained herein.. Both safety and durability rely very much on the correct identification, installation and a good understanding of ratings, features, design, maintenance and operation procedures.

The information, specifications, illustrations and statements contained within this publication are given with our best intentions and are believed to be correct at the time of going to press.

Our policy is one of continued development and we reserve the right to amend any technical information without prior notice.

Whilst every effort is made to ensure the accuracy of the particulars contained within this publication neither the manufacturer, distributor, or dealer in any circumstances shall be held liable for any inaccuracy or the consequences thereof.

1.2 Service and maintenance

Regular service and maintenance should be carried out according to the directions in this manual. For service and maintenance one can appeal to the manufacturer or the dealers.

1.3 Guarantee

WhisperPower guarantees that this Genverter has been built according to good workmanship, according to the specifications in this manual and according to European Community safety regulations.

During production and prior to delivery, all of our Genverters are tested and inspected.

This Genverter's proper operation is subject to guarantee. The period and conditions of this guarantee are laid down in the general conditions of delivery as registered with the Chamber of Commerce and Industries for the North of the Netherlands number 01120025 and are available on request. The guarantee period is two years, limited to 1000 running hours. Some aspects of our guarantee scheme are given here in more detail:

Guarantee does not cover failures that are caused by misuse, neglect or a faulty installation.

WhisperPower cannot be held responsible for damage caused by the unattended running Genverter.

1.4 Liability

WhisperPower does not accept responsibility for damage, injuries or casualties which are the result of operation of the Genverter in specific conditions which brings dangers which could not be foreseen, or could be avoided by additional measures. WhisperPower does not accept liability for damage due to use of the Genverter, possible errors in the manuals and the results thereof.

1.5 Identification

1.5.2 Identification plate

All required identification data are on the identification plate, providing the following information

The identity of the Genverter is given by the SERIAL NUMBER.

POWER

The identification plate gives the maximum load in kVA (= kW) calculated with power factor one. When calculating a load one should always take into account the power factor or cos phi of this load. The load should never exceed the nominal power as shown on the identification plate. Power is rated at an ambient temperature of 25°C. For higher temperatures the Genverter has to be de-rated.

The identification plate also shows the maximum CURRENT that is acceptable at the specified frequency, voltage and power factor.

DC VOLTAGE is the voltage of the starter battery.

The (approximate) net dry WEIGHT is shown in kg. This is without fuel, oil, cooling liquid, packing and external installation equipment

The CE symbol shows that the Genverter has been built according to European Community safety regulations. Refer to EC Declaration of Conformity for more details.

2 INFORMATION

2.1 Safety

2.1.1 Warnings and symbols

Safety instructions and warnings are marked in this manual by the following pictograms, indicating that a piece of equipment, routine, circumstance, procedure, etc. deserves extra attention:



WARNING

This warning symbol draws attention to special warnings, instructions or procedures which, if not strictly observed, may result in damage or destruction of equipment, severe personal injury or loss of life.



WARNING, Moving machinery

This symbol indicates that a potential hazard exists caused by moving parts and draws attention to special warnings, instructions or procedures which, if not strictly observed, may result in severe personal injury or loss of life.



WARNING

This danger symbol refers to toxic danger caused by Carbon monoxide (CO) and draws attention to special warnings, instructions or procedures which, if not strictly observed, may result in severe personal injury or loss of life.



DANGER

This danger symbol refers to electric danger and draws attention to special warnings, instructions or procedures which, if not strictly observed, may result in electrical shock which will result in severe personal injury or loss of life.

2.1.2 General

When correctly installed and used in normal circumstances this Genverter fulfills EC safety regulations. This Genverter could be part of an installation or could be used in a way that additional regulations of the EC or other authorities have to be taken into account. Refer to the Declaration of Conformity in this manual.

Circumstances could make it also necessary to take additional measures. Be aware of wet conditions and hazardous environments caused by explosive gases etc.

2.1.3 Organizational measures

The user must always:

- have access to the user's manual;
- be familiar with the contents of this manual. This applies in particular to this chapter, Safety Guidelines and Measures.

2.1.4 Maintenance & repair



WARNING

When service has to be carried out while the engine is running, be aware of moving parts.

If the W-GV4 Piccolo is switched off during maintenance and/or repair activities, it should be secured against unexpected and unintentional switching on:

- remove the AC supply;
- remove the connection to the batteries;
- be sure that third parties cannot reverse the measures taken.

If maintenance and repairs are required, use original spare parts only.

Always consult the manual before carrying out maintenance.

2.1.5 Electrical safety

Warning signs indicate parts which could be live.

- Check all wiring at least once a year. Defects, such as loose connections, burned cables etc. must be repaired immediately.
- Do not work on the electrical system if it is still connected to a current source. Only allow changes in your electrical system to be carried out by qualified electricians.
- Connection and protection must be done in accordance with local standards.

2.1.8 Operation

There are no external moving parts like fans and V-belts. The hot parts of the engine are covered by the sound shield and therefore the M-GV4 PICCOLO is very safe when the sound shield is closed.

Nevertheless take note of the signs on the Genverter which show symbols in a triangle indicating danger.

- The Genverter should be operated by authorized personnel only.
- Be aware of hot parts and especially parts of the exhaust system and the cooling system.
- Do not use the M-GV4 Piccolo inside a boat house or in other enclosed areas.
- If the Genverter is unsafe, fit danger notices and disconnect the battery positive (+) lead so that it cannot be started until the condition is corrected.
- Do not attempt to operate the Genverter with a known unsafe condition. Disconnect the battery positive (+) lead prior to attempting any repairs or cleaning inside the enclosure.
- Always consult the manual before carrying out maintenance.
- Do not change the settings without consulting the manufacturer. Keep a record of setting changes in this manual.

2.1.9 Fire and explosion

Fuels can be flammable. Proper handling limits the risk of fire and explosion.



WARNING

Never use the W-GV4 Piccolo in situations where there is danger of gas or dust explosion or potentially flammable products!

- Avoid refilling the fuel tank while the engine is running. When oil or fuel is leaking do not use the GV4 Piccolo.
- Hydrogen gas generated by charging batteries is explosive. Ensure for proper ventilation. Do not smoke or allow sparks, flames, or other sources of ignition around batteries.
- Keep a fire extinguisher on hand.

2.1.10 Chemicals

- Fuels, oils, coolants, and battery electrolyte can be hazardous if not treated properly. Do not swallow or have skin contact with these liquids. Do not wear clothing that has been contaminated by fuel or lubricating oil.
- On no account allow any unprotected skin to come into contact with the injector spray as the fuel may enter the blood stream with fatal results.
- Engines may be fitted with seals or O-rings manufactured from "Viton" or similar material. When exposed to abnormal high temperatures in excess of 400°C an extremely corrosive acid is produced which cannot be removed from the skin. If signs of decomposition are evident, or if in doubt, always wear disposable heavy duty gloves.

2.2 Transport, lifting and storage

When lifting the Genverter avoid any risk of personal injuries, do not stand under the Genverter.

- Use soft slings to avoid damage
- On the engine is a lifting hoist eye which can be used to take the Genverter out of the capsule. It can also be used to lift the complete Genverter including the capsule.
- After transporting the Genverter check for damage before installation.
- Long term storage can have detrimental effects on engine and alternator. The engine should be put through an engine preservation procedure. (Refer to the maintenance chapter).

- The alternator windings tend to condense. To minimize condensation, store the Genverter in a dry and warm storage area.

* While the battery is stored it should be recharged every 12 weeks.

2.3 Features

2.3.1 General

The WhisperPower Genverter combines a small oil cooled diesel engine, a Permanent Magnet alternator and an Inverter, making variable speed possible. Variable speed means that the engine will operate at low rpm when little power is needed and at high speed up to 3600 rpm when a high output is demanded. Because of variable speed the unit operates much more economic (less fuel consumption), the life time is much longer than generators that run constantly at high speed and the noise is much lower when running at low speed.

2.3.2 Construction

The Genverter incorporates a diesel engine which has a permanent magnet alternator in the flywheel. The engine is mounted on a steel base frame and mounted securely on a double set of anti-vibration mounting pads in a sound attenuated canopy. The output of the power from the alternator will be about 300V-400Hz and 400V-500Hz, depending on the engine speed. The separate power module will invert this output to 230V 50Hz.

2.3.3 Control

Digital Diesel Control, incorporated in the Power Module Genverter, is based on microprocessor technology. DDC takes care of engine operation monitoring and control (refer to Digital Diesel Control user's manual for DDC specifications and possibilities).

The full automatic remote control panel including 10 meter cable comes as standard with the Genverter.

2.3.5 Documentation

Included in the delivery are:

- This user's manual (number: 40200821)
- An installation manual (number: 40200831)
- A DDC operating manual (no. 40200801).
- A DDC quick reference guide (no. 40200142)

The user's manual contains a list of important maintenance and spare parts as well as a chapter on maintenance and problem solving. Manuals in other languages are available on request.

3 TECHNICAL INFORMATION

3.1 Parts and relevant functions

The W-GV4 Piccolo Genverter is a very advanced high tech variable speed power supply system. It combines new technologies from different fields such as engine technology, PM alternator technology and inverter technology.

3.1.1 Engine

The engine used in the Genverter is developed by WhisperPower and manufactured exclusively for WhisperPower. The concept is unique as the engine is fully cooled by oil. The same oil that is used for lubrication is also used for cooling. However the lubrication circuit is separate from the cooling circuit that has its own pump.

As the cylinder and cylinder head are surrounded by oil the noise of the engine itself is extremely low. The oil cooling makes it possible to apply the engine in an almost fully enclosed canopy, what makes the Genverter even more silent. The oil is cooled by a relatively small heat exchanger.

The heat exchanger is standard integrated in the sound shield canopy, but can be placed separately (not standard).

One could use the hot oil for generating heat (CHP Combined Heat Power generation). For this application additional information can be provided by WhisperPower.

The engine is directly injected and designed to meet the highest exhaust emission standards.

Further details are in the data sheet on page 16.

3.1.2 AC Permanent Magnet Alternator

The Three Phase Permanent Magnet Alternator is incorporated in the flywheel and has a very high efficiency of 94% or higher because of the very high tech super magnets that are used. The output of the power from the alternator will be between 250V-300Hz and 400V-500Hz, depending on the engine speed. As the efficiency is very high, little cooling is needed. The alternator includes a fan that circulates air to cool the windings.

Further technical data on the design of the alternator can be found in drawings and diagrams in this manual.

3.1.3 Control

WP-PMG POWER MODULE GENVERTER

Through the WP-PMG Power Module Genverter, the user can control and operate the GV4 Piccolo.

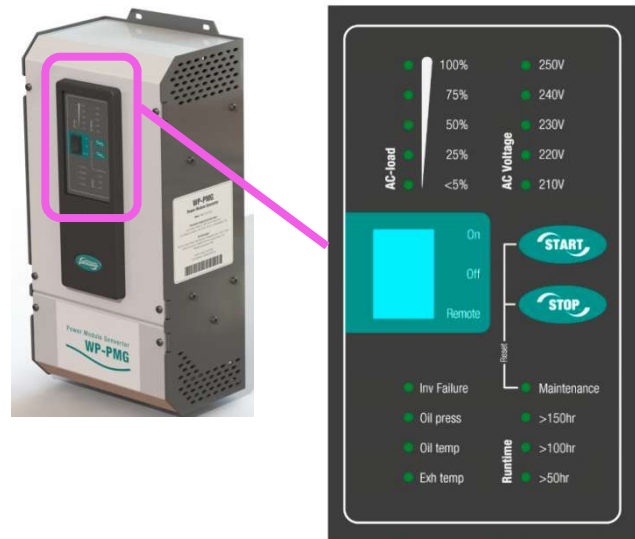

Figure 1: WP-PMG control panel

By pushing the START button on the PMG control panel (refer to Figure 1) for two seconds, the control system is activated and will start the engine automatically. Pushing the STOP button (again hold two seconds) will stop the engine and the electrical system will be deactivated.

DIGITAL DIESEL CONTROL SYSTEM (either incorporated in the WP-PMG or integrated in the DDC control box)

Digital Diesel Control is a very advanced functionality taking care of engine monitoring and control. Depending on the Piccolo system, the DDC is either incorporated in the WP-PMG or it is part of the DDC control box. DDC microprocessors manage both the WP-Piccolo engine and the combined engine - inverter operation.

DDC provides options for the Piccolo user to realize advanced settings and functionality. Change DDC settings by means of the DDC remote control panel to be able to operate the WP-GV4 Piccolo in variable speed or automatic mode.

Refer to Section 4.2. and the DDC operational manual for detailed instructions.

REMOTE CONTROL PANEL (applicable for the DDC control box configuration)

The DDC box remote control panel displays various process parameters and it allows the user to realize operational settings.



1. Start button
2. Stop button
3. Select button
4. Set button
5. Failure lamp
6. Generator load indicator
7. Display

Figure 2: Digital diesel remote control panel

3.1.4 Power Module Genverter

As far as PMG operation and functionality is concerned, the reader is referred to the PMG User's Manual.

3.1.6 Battery charger

The WP-Piccolo system includes a battery charger generating 7A 13.7VDC to charge the starter battery.

3.1.7 Load indicators

Refer to Figure 3: both the PMG local panel and the remote control indicate the AC load. Also the optional external DDC control box – if applicable – displays the load.



Figure 3: Remote and DDC box load indication

3.1.8 Fuel

SPECIFICATIONS

The engine must only be used with diesel fuel oil which conforms to the standards for use in modern diesel engines. Fuel free from water and contaminants is of the utmost importance. Detailed fuel specifications are listed in section 3.2.2.

BIO-DIESEL

The use of diesel fuels to a maximum blend of 5% (by volume) of Fatty Acid Methyl Esters (FAME) known on the market as B5 diesels is allowed as far as these B5 diesel fuels meet the requirements in section 3.2.2.

Bio-fuels should be supplied by recognized and authorized suppliers only.

DIESEL PREHEATER

As an option a diesel pre-heater can be mounted. This is a special feature for applications in extreme cold conditions. In this case the fuel filter will be inside the canopy and before the filter will be a heating element that will prevent the formation of paraffin crystals in the diesel and clogged filters as a result. The operation is temperature-related. The system is controlled by an independent switch to turn it "on" or "off".

3.1.9 Lubricating oil

SPECIFICATIONS

The engine must be run on heavy duty lubricating oil meeting the requirements in section 3.2.3. A well-known brand is recommended.

It is very important to use the correct oil specification. Very often local oil suppliers recommend a higher API class, because they assume that a higher class is allowed. This is not the case. One should not follow these recommendations as these higher class oils contain additives that could cause high oil consumption.

Never mix different types of oil.

OIL VISCOSITY

We recommend multi grade oil 15W40. Cold or hot conditions a special grade could be applied according to the Viscosity Chart below:

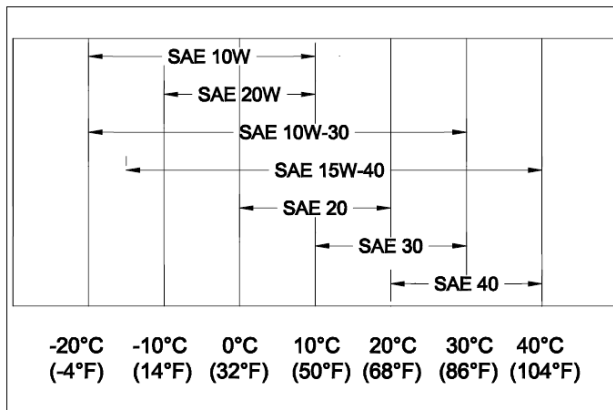

Figure 4: Viscosity chart

It is very important to select the right viscosity. Especially in cold conditions the viscosity of the oil should be low (so the oil should be “thinner”) to keep the oil pressure in the cooling system within acceptable limits.

OIL CAPACITY

The content of the crankcase should be:

- excluding heat exchanger and piping: 2 liter
- including heat exchanger and 2 m piping: 2.9 liter

Do not overfill with lubricating oil as this may have a detrimental effect on engine performance.

Refer to the maintenance chapter (Ch.5) for details.

LUBRICATING OIL PRESSURE

- Minimum at idle:
49 kPa (0,5 kgf/cm² - 7psi)
- Normal at 3000 rpm:
147 .. 490 kPa (1,5 .. 5 kgf/cm² - 21 .. 71 psi)
- Minimum at 3000 rpm:
98 kPa (1,0 kgf/cm² - 14 psi)

COOLING OIL PRESSURE

- Minimum at idle:
149 kPa (1.5 kgf/cm²-21 psi)
- Normal at 3000 rpm (80°C):
180 .. 220 kPa (1,8 .. 2.2 kgf/cm² – 25 .. 35 psi)
- Maximum cooling oil pressure is protected by an overpressure switch that will trip at 550 kPa (5.5 kgf/cm² – 80 psi).
In cold condition the pressure can be higher, but the alarm will be suppressed.

COOLING OIL TEMPERATURE

- Maximum oil cooling temperature 120°C (oil out to the cooler).
- Minimum oil temperature 70°C.
- Sump oil temperature should be between 80°C and 90°C for optimal performance

3.1.10 Oil cooling heat exchanger

The M-GV4 Piccolo engine is cooled by oil and not by cooling liquid. The oil cooled heat exchanger of the M-GV4 Piccolo is not ventilated. The system is ventilated by the engine itself and no expansion tank is applied.

When it is not possible to drain the oil from the heat exchanger every time the oil is changed, one should pump out the engine oil from the engine sump as well as possible and increase the oil change frequency to once every 100 running hours.

A dedicated interval recommendation can be provided for special applications by WhisperPower.

3.2 Technical data

3.2.1 General

M-GV 4 Piccolo Genverter Marine	
Article no. 49002005	
Programmable rpm variable speed single phase Genverter	
1 cyl. 230V / 3.8kVA / 50Hz - PM Technology	
GENERAL SPECIFICATIONS	
Intermittent power	4.4kVA / 4.0kW at 3600rpm
Continuous power (ambient temperature?)	4.4kVA / 3.5kW at 3000rpm
Peak power, 5 seconds	8kVA, surge 200%
RPM range	2800 .. 3600rpm, programmable rpm
Nominal output voltage, frequency	230V, 50Hz
Nominal output current	20.5A
Voltage tolerance	± 5%
Frequency tolerance	± 0.1%
MECHANICAL DIMENSIONS AND WEIGHT	
Genverter h × w × d	520 × 450 × 461mm
Genverter dry weight	68.8kg (incl. polyester sound shield)
WP-PMG h × w × d	420 × 196 × 148mm
WP-PMG dry weight	7.2kg
WP-GVC remote panel h × w × d	55 × 144 × 22mm (table top, flush mounting)
WP-GVC remote panel weight	0.4kg
Temperature range operational	-10°C .. 40°C, derating to zero at 65°C
Temperature range storage	-20°C .. 70°C
Protection degree	Engine compartment: IP21 Electronic compartment: IP21
Max. operating angle	25° in all directions
Relative humidity	Max. 95% RH, non-condensing
Material, color	GRP sound shield, RAL 9010 white, black metallic
Service interval	150h
ENGINE SPECIFICATIONS	
Engine brand	WhisperPower
Engine model	WP1
Intermittent power	4.8kW / 6.4hp rated at 3600rpm, SAE J1349, ISO 3046/1
Continuous power	4.3kW / 5.8hp rated at 3000rpm
Number of cylinders	1
Operation principle	Energize to run
Displacement	0,306 liter
Bore & stroke	78 × 76mm
Air intake system	Naturally aspired
Combustion air consumption	0.42 m3/min
Fuel	Fuel
Fuel consumption	0.8 .. 1.2 liter/h
Fuel temperature	Fuel temperature Max. 40°C at fuel injection pump
Fuel lift pump engine Electrical pump 12VDC external	Electrical pump 12VDC external (standard included)
Oil capacity	2 liter
Oil exchange	External suction pump (not included)
Service interval oil change	200 hours
Engine cooling	Indirect oil-cooling to sea water by heat exchange
Nominal control voltage	Electrical 12VDC, common ground
Nominal starter battery requirement	12V, 55Ah
Battery charger function	Integrated in WP-PMG
Protections	Oil temperature, coolant, exhaust temperature



ALTERNATOR SPECIFICATIONS	
Type	Permanent Magnet Alternator (PM)
Model	16Nm (5kW at 3000rpm), inner rotor, air cooled
Nominal output	420V, line-line, 9.2A, 400Hz, 3 phase star configuration 533Hz
Rotor / stator	105 .. 419V line-line at 1000 .. 4000rpm, 133 .. 533Hz, 24 coils, 16 poles
Insulation grade	Class F, max. 155°C, 3.6kV, 500Hz
Peak efficiency	94%
Cooling	Forced air
Rotor balancing	ISO 1940 G2.5
SOUND SHIELD SPECIFICATIONS	
Material	Polyester, with inner bitumen layer
Insulation	25mm layer
Audible noise level open field	54dBA at 7 meter, 65dBA at 1.5 meter
POWER MODULE SPECIFICATIONS	
Model	WP-PMG Power Module Genverter 4kW frame 1
Input voltage / current / frequency	360 .. 440V, 11A, up to 500Hz, 3 wire (L1, L2, L3)
Output voltage / current / frequency	230V, 16.5A, 50Hz, 3 wire (line, Neutral, PE)
Voltage Total Harmonic Distortion (nominal load)	> 3% THD
Efficiency	Peak 95%, average 93%
Cooling	Forced air cooling
Generator control	Local start/stop; local read out module
Optional generator control	WhisperPower DDC, auto Start / Stop compatible
Standard remote control LED remote panel, 10 mtr cable,	LED remote panel, 10 mtr cable, plug and play RJ12 connectors
COMPLIANCE	
Directives:	EMC 2004/108/EC, EMC 2004/104/EC (automotive), LVD 2006/95/EC
Standards:	EN 55022 (emission), EN 61000-3-2 (harmonics), EN 61000-4-11, EN 61000-3-3 (voltage fluctuations), EN 61000-6-2 (immunity), EN 60950-1, EN 609335-1, EN 60335-2-29 (safety), EN 68-2-6 (vibration), EN 6094 (maritime navigation and radiocommunication), UL 458 (power converters / inverters)
SYSTEM ACCESSORIES	
Base plate (optional)	Aluminium mounting plate 600 × 400mm
Wet exhaust hose	Ø 40mm, 1 $\frac{1}{8}$ "
Water lock	Ø 40mm, 1 $\frac{1}{8}$ "
Water gas separator	Ø 40mm, 1 $\frac{1}{8}$ "
Fuel filter / water separator	30micron
Fuel inlet and return	Ø 8mm tube
Inlet valve / sea water scoop	½ .. ¾" inlet, Ø 12.5mm out
Water strainer in/out	Water strainer in/out Ø 12.5mm
Siphoning valve	Siphoning valve Ø 12.5mm
Seawater inlet suction hose	Seawater inlet suction hose Ø 12.5mm
Underwater inlet / filter	Ø 12.5mm
Starter battery AGM 12V - 55Ah	AGM 12V - 55Ah
Starter kit:	Starter kit:
- Inverter / charger	WP-Combi, WP-Supreme Combi
- Battery charger	WP-Supreme battery charger
- Service batteries	AGM / GEL

3.2.2 Fuel specifications

Diesel Fuel Specification	Location
EN590:96 Bio-diesel: EN 14214	European Union
BS 2869-A1 Or A2	UK
No. 2-R, No 1-D, ASTM D975-94 Bio-diesel: ASTM D-6751	USA
GB252	China
ISO 8217 DMX	International
JIS K2204 Grade No.2	Japan
KSM-2610	Korea

3.2.3 Lubricating oil specifications

The engine must be run on heavy duty lubricating oil meeting the requirements of API class CH-4, CI-4 or CJ-4. It is recommended to use a well-known brand.

3.2.4 Electrical diagrams

Refer to the WP-GV4 Piccolo Installation Manual for system drawings presenting connections and wiring.

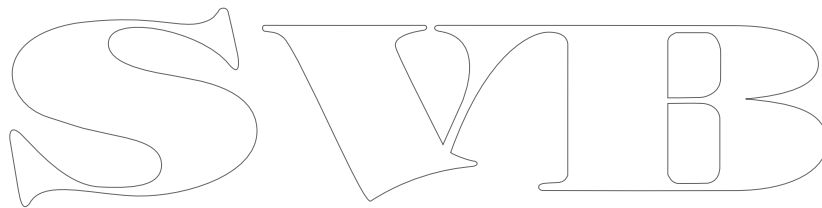

4 OPERATION

4.1 General

The GV4 Piccolo is operational after full installation and filling up with fuel and engine lubricating oil; and subsequently connecting the battery and digital remote control panel. Fill with lubricating oil twice to allow the heat exchanger to get filled with oil. This is done by filling up with oil first, run for 60 seconds, and then stop the engine and fill up again.

When checking the oil level inside the lubricating oil reservoir, simply dip the dipstick into the oil without screwing the dipstick into the sump.

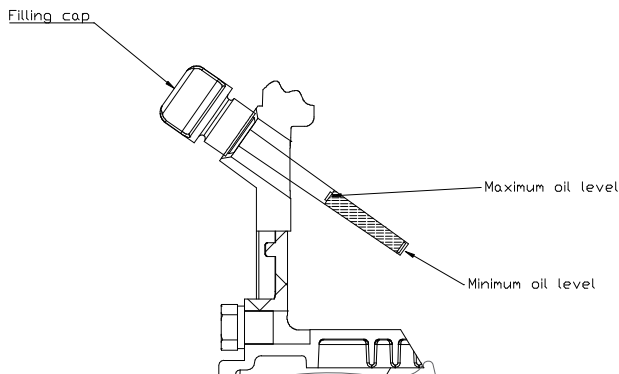

Figure 5: Oil dipstick

ADJUSTING GENERATOR FREQUENCY

The Piccolo operates on fixed speed. Use the speed regulator (refer to Figure 6) to manually adjust speed (according preset speed ranges as documented in the specifications), if preferred. Untighten the regulator, move downward to adjust speed and tighten again.

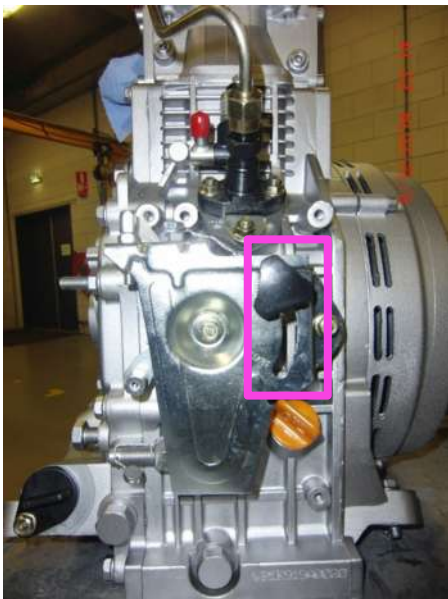

Figure 6: Speed regulator

4.2 Variable speed mode

Realize variable speed operation by changing DDC settings by means of the DDC remote control panel. Refer to the DDC operational manual for detailed instructions.

In variable speed mode the engine will start when the starting button is pushed. The speed will adapt to the load. When an additional load will be switched on the engine will speed up. To avoid that the engine will not provide enough power to speed up while a new heavy load is added, the Minimal Engine Speed has to be set to a minimum (worst case) level from which the engine will be able to speed up again.

Example: When the engine is running at no load (or almost no load at 2500 rpm) and a 3 kW load (e.g. an air-conditioner) with an inrush current for motor starting of 4 x nominal power is switched on, the engine will probably not be able to ramp up the rpm. In this case the low speed setting has to be higher; possibly 2800 rpm. However when load steps of only 1 kW are switched on, one after another, a low speed setting at 2500 rpm will be OK. The optimal low rpm setting can be established by trial and error.

4.3 Operating instructions

While in operation, monitor the Piccolo AC load and voltage by means of the PMG panel LED indicators.

4.3.1 Summarized operating instructions (daily use)

"PRE-START" CHECKS

Perform the following routine "pre-start" checks prior to starting the WP-GV4 Piccolo:

- 1 Check oil level
The GV4 Piccolo Genverter switches off in the event of insufficient oil pressure. Even when the oil level is too low, the oil pressure can be high enough not to trip an alarm. Do not run the engine with the oil below the lowest mark, because a smaller volume of oil will become contaminated considerably quicker than a larger volume. Also the cooling can be affected. Therefore we recommend daily oil-checks. Check oil level prior to starting the engine or at least 5 minutes after the engine has stopped.
- 2 Check for leakages.
- 3 Switch to power source selector switch to "OFF", or switch off all consumers in the usual way.
- 4 Switch on the battery switch (when installed).
- 5 Make sure the fuel valve is open.

STARTING ROUTINE AND CHECKS



Figure 7: WP-PMG local panel

Start the WP_GV4 Piccolo:

- 1 Push the START button on the WP-PMG local panel (Figure 7) and hold for two seconds to initiate the full automatic starting procedure. As a result, the electric system is activated.
You can monitor the procedure on the remote control display.
The first time starting up or after running out of fuel it could be necessary to prime the fuel system. Refer to bleeding fuel system instructions in the maintenance chapter 5.2.2.
- 2 In case of a 'cold start' (starting problems may occur in open air and/or, under winter conditions) the small orange oil screw plug on the cylinder head cover has to be removed. Add 2ml of engine lubrication oil before starting. Push down the decompression lever. It will return automatically when cranking.
Never use ether or gasoline for cold start as it could damage the engine.
Warm up the engine without load for 3 minutes.
- 3 A restart protection prevents starting the engine when it is already running, which may cause damage.

CHECKS WHILE IN OPERATION

When in operation: perform the following operational checks on a regular basis:

- 1 Check for abnormal noise or vibration
- 2 Check the output parameters on the remote control display.
- 3 Switch the power source selector switch to "Power Source Genverter". Before loading the Genverter up to maximum, have it run warm.
Make sure that continuous load does not exceed 70% of maximum load (also refer to "CHECKS DURING LONGER OPERATION"). This is indicated on the top left part of the PMG local panel (Figure 7).

- 4 Observe the exhaust at the normal full load.
The exhaust must be free from soot. Do not allow the engine to run with a dirty exhaust without investigating the cause as this may result in an expensive breakdown. When ramping up rpm, the engine will probably produce some smoke. After stabilizing on the right rpm for the load the exhaust should be free from soot.

STOPPING ROUTINE

How to stop then WP-GV4 Piccolo Genverter:

- 1 Switch off all electrical devices (consumers).
If the GV4 Piccolo has been running under full load for a longer period, do not shut it down abruptly. Reduce the electrical load to about 30% of the rated load and let it run for approx. 5 minutes.
- 2 Press the PMG STOP button (Figure 7) and hold for 2 seconds.
- 3 Switch to another AC power source, if available.

4.3.2 Extended operating instructions

FIRST TIME CHECKS

Check when starting the first time or after a longer period of rest:

- 1 Check for any damages caused by transport or installation.
- 2 Check if the installation conforms to the installation instructions.
- 3 Ensure the engine is free to turn without obstruction.
- 4 By using the decompression handle one can crank the engine easily with a screwdriver (clockwise) pushing the starter gear.
- 5 Check all hoses and hose connections for leaks.
- 6 Check all cables and terminal connections.

CHECKS DURING LONGER OPERATION

Check engine load during longer operation. The first 50 hours of running the continuous load should be restricted to 70 % of maximum load. Running for long periods at no load or light load in the first 50 hours can cause cylinder glazing and high oil consumption.

- 1 Ensure that the WP-GV4 Piccolo is not overloaded.
Overloading occurs when the electrical load (demand) is so high that the alternator cannot be turned around properly by the diesel engine. Overloading causes the engine to run rough, while using oil and excessive fuel and producing soot by the exhaust. The engine can even stop.
The Genverter should therefore only be loaded at the maximum rated power for short periods (2-3 hours) only!

The high peak current is meant for the ability to start electrical devices that need a high current for starting especially electric motors and compressors (from a still stand state).

In order to prolong the Genverter life expectancy, the nominal electrical demand on the system should be about 70% or the rated Genverter's maximum load. Please note this when switching on your electrical devices!

Nevertheless, the M- GV4 Piccolo is designed so as not to overheat, even under extreme conditions.

- 2 Do not run the Genverter for very long periods at no load or at very low load. When this is necessary, do load the Genverter at least one hour in 10 hours for minimum 70%. Long term running at too low load will cause the exhaust to be choked by carbon (soot).

**WARNING !**

Never remove the battery while the engine is running or any electrical cable while the battery is connected in the circuit. Only disconnect the battery with the engine stopped and all switches in "OFF" position.

STOPPING AFTER LONGER OPERATION

Avoid stopping of the Genverter abruptly after a long period of operation at high load! Doing so, you avoid unnecessary

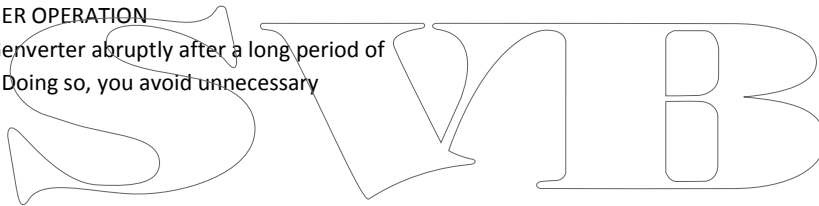

thermal load to the engine!

Furthermore, do not stop the engine with the decompression lever unless in emergency when there is total loss of control.

Act as follows:

- 1 Prior to switching off the WP-GV4 Piccolo, decrease the load (i.e. turn off most electrical users) and let the Piccolo run at low load for approx. 5 minutes to allow the engine to get properly cool (the influent coolant oil must flow through the system in order to cool the engine).
- 2 If the Genverter is operating in a hot environment and you do not act as given above, the excessive heat in the engine can trip the "high temperature" alarms. In that case, a restart of the engine is not possible for some time. It is also recommended to switch off electrical users prior to stopping the Genverter because of the voltage drop that occurs as the engine comes to a halt.
- 3 Press the STOP button and hold for 2 seconds.
- 4 Switch to another 230V power source, if available.

5 MAINTENANCE

5.1 Maintenance intervals

Service level			break-in	1	2	3	4
		before each start	after 35-50 h	every 200 h/ 6M*	every 400 h/ 12M*	every 800 h/ 24M*	every 1600 h/ 36M*
Lubricating oil	check oil level	●					
	change oil and oil filter cartridge		●	● (12M)			
	check lubricating oil pressure						□
Cooling system	check and clean radiator (if installed)				●		
	replace water pump impeller				●		
	check hoses					●	
Exhaust	check exhaust		●				
Nuts & bolts	check all and tighten where necessary		●				
Electrics	check all electrical connections		●			●	
	check battery (acid level, connections)			●			
Fuel system	drain water from tank			●			
	replace fuel filter				●		
	check fuel hoses					●	
	check injection nozzles and injection pressure						□
	check injection pump						□ (3200h)
Air supply	check air strainer and filter element				●		
Cylinder head	Retighten cylinder head bolts and readjust valve clearance				●/□		
* Whichever comes first.							
● Can be done by user. Corrective action to be taken whenever necessary.							
□ WhisperPower service center to be contacted.							

5.2 Alternator

The alternator does not require any maintenance.

5.3 Engine

5.3.1 Preliminary instructions

All regular maintenance can be carried out when the enclosure is open. When oil and dirt has gathered in the enclosure measures have to be taken to avoid spilling oil and polluting the environment.

The first service on the engine should be carried out after 50 hours of its life and after a major overhaul. In the first 50 hours the engine should receive special attention:

- Long periods of light or no load running in the first 50 hours may lead to cylinder glazing and high oil consumption.
- For the same reason it is of the greatest importance to use the right oil specification.
- The first time starting up or after running out of fuel it could be necessary to prime the fuel system.

5.3.2 Bleeding fuel lines

Ensure there is sufficient fuel. The system is self-bleeding. The first time starting up or after running out of fuel it could be

necessary to prime the fuel system. Push the start button activating the electric system and activating the fuel pump. When more time is needed to bleed, push “start” and “hold” the button on the local control panel (so not on the remote panel). When holding the button the pump will work, but the unit will not start. Hold as long as necessary to bleed the system.

5.3.3 Valve clearance

When the engine is in cold condition both valves (inlet and outlet) should have a clearance of $0.15 \pm 0.03\text{mm}$.

5.3.4 Replacing fuel filter

Filter change is needed when the fuel is contaminated and as part of preventive maintenance at least every 400 running hours. Before changing the filter, clamp off the supply line. Remove the hoses from filter and attach them on the new filter again. The arrow on the filter housing indicates the direction of the flow. A clogged filter results in a lack of output of the engine and irregular running.

5.3.5 Cleaning oil strainer

The oil strainer is in front of the service side. Cleaning has to be executed according to the maintenance schedule (refer to section 5.3.1 and Chapter 7). Drain the oil using a vacuum pump; put some tissues under the cap.

5.3.6 Air filter element

The W-GV4 Piccolo is standard supplied with an air inlet filter element. Filter change depends on environmental contamination. Check the air filter at least every 400 running hours. The foam around the filter element can be cleaned by compressed air. Do not use solvents to clean the foam. The filter cannot be cleaned and must be replaced. Access to the filter can be obtained by unscrewing the wing nut and pulling the engine towards the service side. The filter can now be replaced.

5.4 Regular maintenance

5.4.1 Changing oil and cleaning the oil strainer

In practice it will not be possible to change all oil in the system, because some oil will be left in the cooling system. Therefore we recommend changing the oil twice, especially at the end of break-in:

Have the engine run until it is on temperature and stop it. Drain oil by using a vacuum pump as commonly used in garages. Refill the engine with oil; start the engine and have it run for 5 minutes. Stop the engine and pause for a few minutes to let the oil gather in the crankcase.

The oil strainer can be found left below on the service side. Drain the oil again and put some tissues under the oil strainer cap before removing it. Take out the strainer element and clean it if necessary using tissue or white spirit.

Refill with fresh oil for the second time. Start again; after 5 minutes stop; pause for a few minutes check the level and add oil if necessary.

5.4.2 Checking the battery

Check the battery terminals for corrosion and clean if necessary.

If an open lead-acid battery is being used, maintain the electrolyte level between UPPER and LOWER marks on the case. If the battery has not got any level marks, maintain the level 10 to 15mm above the cells. Remove the filler caps and add distilled water when necessary.

5.4.3 Draining water from the fuel tank

Remove the drain plug and allow any water and sediment to drain. Drain at least 1 or 2 liters of fuel to remove the water and sediment.

5.4.4 Replacing the coolant pump impeller

When the impeller is replaced, the gasket between the pump case and the cover should be replaced as well (see also 6.2.3).

Remove the cover to get access to the impeller. Remove the old impeller with the help of two screwdrivers. Install the new impeller and add some grease. Turn the blades in the direction of rotation of the pump, i.e. anticlockwise looking at the impeller. Refit the cover using the new gasket.

5.4.5 Replacing the fuel filter

Filter change is needed when the fuel is contaminated and as part of preventive maintenance at least every 400 running hours. Before changing the filter, clamp off the supply line.

Remove the hoses from filter and attach them on the new filter again. The arrow on the filter housing indicates the direction of the flow. A clogged filter results in a lack of output of the engine and irregular running.

5.4.6 Air filter element

The W-GV4 Piccolo is standard supplied with an air inlet filter element. Filter change depends on environmental contamination. Check the air filter at least every 400 running hours. The foam around the filter element can be cleaned by compressed air. Do not use solvents to clean the foam. The filter cannot be cleaned and must be replaced. Access to the filter can be obtained by unscrewing the wing nut and pulling the engine towards the service side. The filter can now be replaced.

5.4.7 Checking hoses and electrical connections

Visually check cooling hoses, fuel hoses and electrical wiring, paying particular attention to abrasion, wear and corrosion. Have items replaced when necessary.

5.4.8 Retightening cylinder head bolts and adjusting valve clearance

Both procedures have to be carried out with a cold engine. Be sure to retighten the cylinder head bolts before adjusting the valve clearance. First remove the valve cover.

Loosen the bolts slightly, remove the rocker assembly (the rocker arms, shaft, and stays) and then retighten the bolts to the specified torque in the numerical order illustrated

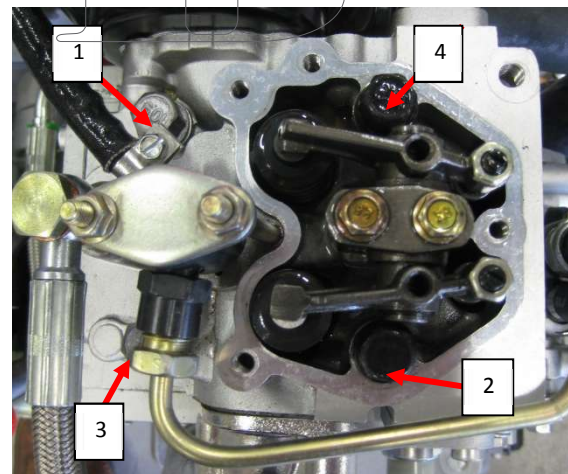

Figure 8: Cylinder head bolts

Tightening torques

Cylinder head screws M9x1,5: 47 to 51 Nm

Rocker arm bracket mounting: M6 x 1: 10 to 12 Nm

Standard torque chart

Size	M6x1.0	M8x1.25	M10x1.5
Nm	10.8 \pm 1.0	25.5 \pm 2.9	49.0 \pm 4.9



Apply 80% torque when tightening bolts to aluminium alloy.

Valve clearance

When the engine is in cold condition both valves should have a clearance of $0.15 \pm 0.03\text{mm}$. The adjustment has to be done at top dead centre (TDC) of the compression stroke. Using a pocket light one can check the position of the flywheel/alternator (refer to Figure 9; for visualization reasons, the PM cover was temporarily removed).

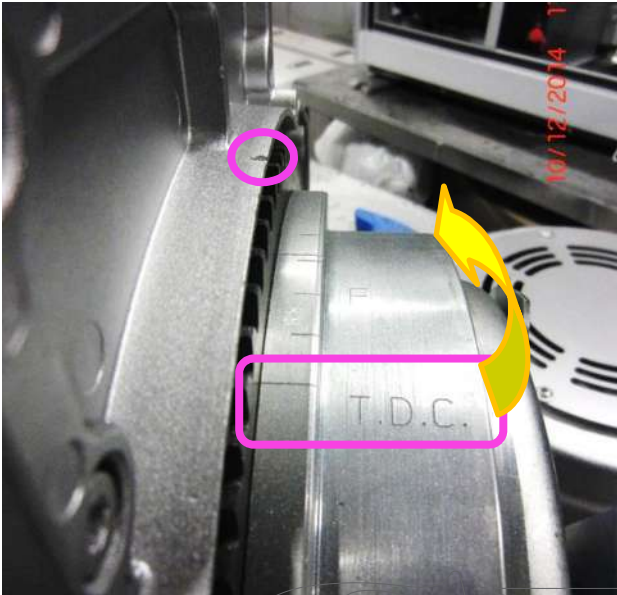

Figure 9: Top Dead Center (TDC)

When one cannot see the mark on the flywheel/alternator, the TDC can be found by rotating the flywheel and watching each valve to open and close.

Rotating the flywheel can be realized by means of the flywheel turning tool (article number 98002002; also refer to Figure 10).

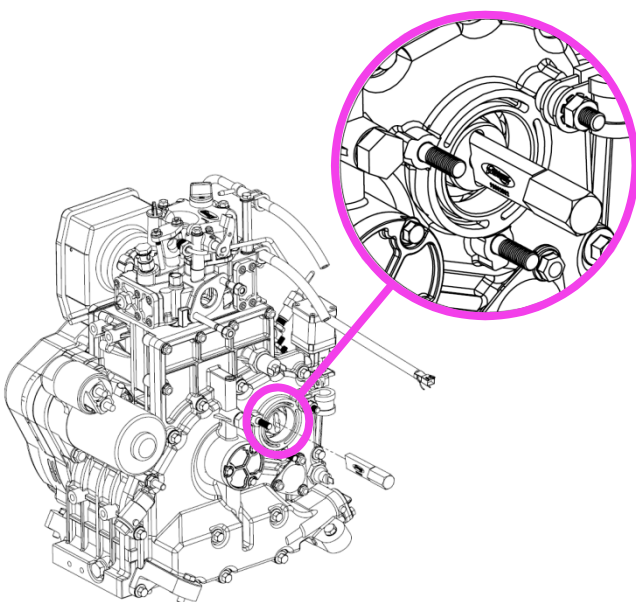

Figure 10: Turning tool to move to Top Dead Center position

To be able to access the turning tool insertion point, first disassemble the water pump. Rotate the flywheel clockwise, allowing the exhaust valve to open and close and the intake valve to open and close. After the intake valve has closed, rotate the flywheel clockwise an additional $\frac{1}{4}$ turn. At this position the piston will be on compression stroke and both valves will be closed allowing valve clearance adjustment to be completed.

Before closing the valve cover apply some oil to the contact surface between the adjusting screw and push rod. Use a new valve cover gasket.

5.5 Putting out of service

When not using the Genverter for a longer period it is recommended to execute an engine preservation procedure.

- 1 Clean the engine.
- 2 Loosen the fuel suction pipe and fuel return and put them in a can with preservation diesel fuel. Start the engine and run the engine warm.
- 3 Stop the engine.
- 4 Drain the hot engine oil and refill with preservation oil.
- 5 Open the orange oil screw plug on the cylinder cover and add 2 cc preservation oil.
- 6 Disconnect the battery and store it in a dry place free of frost and charge it regularly.
- 7 Close inlet- and outlet openings with tape.
- 8 Protect the Genverter against the influences of bad weather conditions.

This method of preservation will be sufficient for 6 months. Change oil before using the engine again.

6 TROUBLESHOOTING

6.1 General

If any problem should occur, check basic conditions and examine all external wiring, switch gear and circuit breakers. Also check if measuring instruments give the correct value. If in doubt, measure directly on the alternator terminals with an independent instrument.

In case of inverter failure or oil pressure, oil temperature or exhaust temperature limit exceeding, the error will be indicated on the PMG local panel (bottom left; refer to Figure 7).

6.2 Alternator/ electrical faults



Beware of parts which are live! The alternator generates voltage up to 650 V.



Remove 3 A fuse from the control panel while working on the Genverter in order to prevent the engine from starting.

6.2.1 Troubleshooting table for alternator

PROBLEM	CAUSE	SOLUTION
No output (voltage) at all	• Circuit breaker "off" or faulty fuse	Check switches and fuses and measure directly on the alternator to exclude external causes.
	• Low engine RPM	Check the engine RPM and adjust
	• Alternator failure	Contact WhisperPower Service
Genverter output voltage too low when in no load condition and RPM is above 2500 RPM	• Alternator failure	Contact WhisperPower Service
Genverter output voltage too low when under load, but OK in no load condition	• Genverter is overloaded	Switch off a load; reduce number of consumers
	• Insufficient engine RPM	Increase minimum RPM setting
	• Engine RPM drops when loaded	Refer to "Engine speed drops" section in 6.2

6.3 Engine faults



Remove 3 A fuse from the control panel while working on the Genverter in order to prevent the engine from starting.

6.3.1 General

When the engine is not cranking well, starting problems almost always originate from battery problems or poor battery cable connections.

When the engine does crank, starting problems almost always originate from lack of fuel or air bubbles in the fuel pipes.

A failure code is displayed when a hardware failure at the engine is detected.

6.3.2 Troubleshooting table for engine

PROBLEM	CAUSE	SOLUTION
Diesel engine fails to crank; no response at all	• Faulty fuse on the control panel	Replace fuse
	• Battery switch off	Switch on
	• Batter completely empty	Charge or replace battery

PROBLEM	CAUSE	SOLUTION
Diesel engine fails to crank, the starter makes clicking noises, or the engine cranks very slowly.	<ul style="list-style-type: none"> • Almost certainly this is a battery problem. Display will indicate "LOW BAT1" 	Check battery voltage. Recharge the battery. Inspect battery terminals and cables for a good electrical connection (inspect for corrosion, tattered wires, etc.)
	<ul style="list-style-type: none"> • Wiring system faulty 	During the normal starting process, the battery voltage drops to 11V (with a fully charged battery). If the voltage does not drop during starting, the electrical connection is faulty. If the battery voltage drops lower than 11V, then the battery has been discharged too deep.
	<ul style="list-style-type: none"> • Starter broken 	Repair the starter motor
	<ul style="list-style-type: none"> • Engine lubricating oil too thick 	Change oil, using a lower viscosity grade
Starter is turning engine smoothly, but engine fails to start	<ul style="list-style-type: none"> • Out of fuel or faulty fuel, water in the fuel 	Fill up with fuel or replace with better quality
	<ul style="list-style-type: none"> • Fuel solenoid is not opening (no "click" can be heard) 	Check wire connections and circuitry to solenoid (refer to Single Line Diagram). Repair if necessary.
	<ul style="list-style-type: none"> • Fuel lift pump is not working 	Check fuel filter and fuel lift pump: clean or replace if necessary
	<ul style="list-style-type: none"> • Air in fuel lines 	Bleed air from fuel system (refer to maintenance section)
	<ul style="list-style-type: none"> • Blocked injector 	Have the injector tested and cleaned if necessary
	<ul style="list-style-type: none"> • Wrong valve clearance 	Adjust valve clearance
	<ul style="list-style-type: none"> • Low compression because of dirty valves 	Contact WhisperPower service department for advice
	<ul style="list-style-type: none"> • Loss of compression by wear out or damage 	Repair by WhisperPower service
Engine runs irregularly	<ul style="list-style-type: none"> • Unsuitable or contaminated fuel 	Fill up with fuel or replace by better quality
	<ul style="list-style-type: none"> • Lack of fuel 	
	<ul style="list-style-type: none"> • Air in the fuel pipes 	Bleed air from fuel system (refer to section 5.2.2)
	<ul style="list-style-type: none"> • Choked fuel filter 	Check fuel filter and replace if necessary
	<ul style="list-style-type: none"> • Disturbances on the electrical system/ user side 	Check whether the equipment using power has higher starter voltage demand. If not, contact WhP service center
	<ul style="list-style-type: none"> • Faulty fuel lift pump 	Check and repair or replace
	<ul style="list-style-type: none"> • Choked air filter 	Check the air intake. Replace air filter if necessary.
	<ul style="list-style-type: none"> • Lack of air 	
	<ul style="list-style-type: none"> • Choked exhaust system, exhaust blocked 	Check the exhaust piping. Contact WhisperPower service department for advice necessary.
	<ul style="list-style-type: none"> • Faulty actuator 	Replace faulty parts. Contact WhisperPower service department for advice.
	<ul style="list-style-type: none"> • Blocked injector 	Have the injector tested and cleaned if necessary
	<ul style="list-style-type: none"> • Wrong valve clearance 	Adjust valve clearance
<ul style="list-style-type: none"> • Lack of fuel 	Check fuel supply system: fuel pump and filter. Clean if necessary	

PROBLEM	CAUSE	SOLUTION
Engine speed drops	• Genverter overloaded	Reduce the electrical load (switch off some consumers)
	• Fuel problem	Check fuel supply and clean fuel filter
	• Too much lubricating oil	Drain oil to proper level
	• Lack of intake air	Check air intake; clean air filter
	• Choked exhaust system, exhaust blocked.	Check the exhaust piping. If necessary, contact WhisperPower service department for advice.
	• Faulty actuator	Contact WhisperPower service department for advice
	• Defective alternator (windings or other)	Genverter must be sent to manufacturer for repair of damaged bearing or winding
	• Damaged engine	Repair by WhisperPower service
Engine does not stop on command	• Fuel solenoid is not switching off	Faulty Digital Diesel Control unit. Stop the engine manually using the stop handle.
	• Loss of control	Check wire connections to stop solenoid. Check solenoid valve function. Replace if necessary.
Engine exhaust smokes	• Faint blue smoke - generally the result of light load	Increase load.
	• Heavy blue smoke - caused by lubricating oil: oil level too high, worn cylinder, stuck, broken or worn piston-rings.	Check the oil-level Check the compression. If necessary, Contact WhisperPower service department for advice.
	• When the engine RPM is ramping up to react at a load step some smoke may be unavoidable.	No action required.
	• Wrong setting of minimum RPM.	Readjust minimum rpm setting
	• Sooty black smoke –incomplete combustion caused by: overload, choked air filter, air inlet temperature too high, unsuitable fuel or water in fuel.	Check the fuel. Check for overload Check the air filter. Replace if necessary
	• Valve clearance incorrect.	Adjust minimal RPM setting Readjust valve clearance
	• Continuous running with very low load.	Increase load and have the engine run for a few hours
	Engine starts, but stops after 10 up to 30 seconds	• Protection system stops the engine; this can be caused by oil pressure failure, loose wire or faulty alarm switch.
• Faulty alarm switch/sensor		Replace the switch. By-passing the switch makes it possible to keep running. But be aware: running with a by-passed alarm switch can cause damage!

PROBLEM	CAUSE	SOLUTION
Engine stops by itself	<ul style="list-style-type: none"> • Overload or short circuit 	Switch off the consumers and test for short circuit. If necessary, contact WhisperPower service department for advice.
	<ul style="list-style-type: none"> • Cooling water temperature too high 	Check raw water pump (refer to section 6.2.3). Replace impeller and/or gasket if necessary
	<ul style="list-style-type: none"> • Lack of fuel 	Check fuel supply system – tank level, fuel lines, pump, filter, valves, etc. – and take appropriate action.
	<ul style="list-style-type: none"> • Oil pressure low (oil pressure switch tripped) 	Check oil level. Refill if necessary. Check oil pressure and have engine repaired by WhisperPower if necessary.
	<ul style="list-style-type: none"> • Air or water in the fuel. • Blocked air or fuel filter. 	Check and clean.
	<ul style="list-style-type: none"> • Loss of compression by wear out or damage. 	Repair by WhisperPower service.
Loss of power	<ul style="list-style-type: none"> • Wrong measurement 	Check if the load is measured correctly. Does the Amp meter show the correct value? When calculating the load by multiplying voltage and amps this should be done using the exact values, taking into account the power factor of the consumers. When in doubt, measure the power directly using an appropriate instrument.
	<ul style="list-style-type: none"> • Oil level too high 	Drain oil to the correct level
	<ul style="list-style-type: none"> • Choked fuel filter 	Replace the fuel filter
	<ul style="list-style-type: none"> • Choked air filter 	Check air inlet openings; clean air filter
	<ul style="list-style-type: none"> • Exhaust blocked 	Check the exhaust system. If necessary, contact WhisperPower service department for advice.
	<ul style="list-style-type: none"> • Injector blocked 	Have the injector checked and – if necessary – repaired.
	<ul style="list-style-type: none"> • Loss of compression, sticking or damaged piston ring 	Have the compression measured. If necessary, contact WhisperPower service department for advice. Clean or replace the rings
	<ul style="list-style-type: none"> • Wear out of cylinder 	Have the compression measured and have the engine overhauled
	<ul style="list-style-type: none"> • Overload 	Reduce the load Clean heat exchanger
	<ul style="list-style-type: none"> • Exhaust choked with carbon • Cooling circuit failure 	Clean exhaust Contact WhisperPower service

6.4 Raw water pump

Exploded view raw water pump (40201270). Replace impeller (50209013) and/or gasket (50209012) in case of failure.

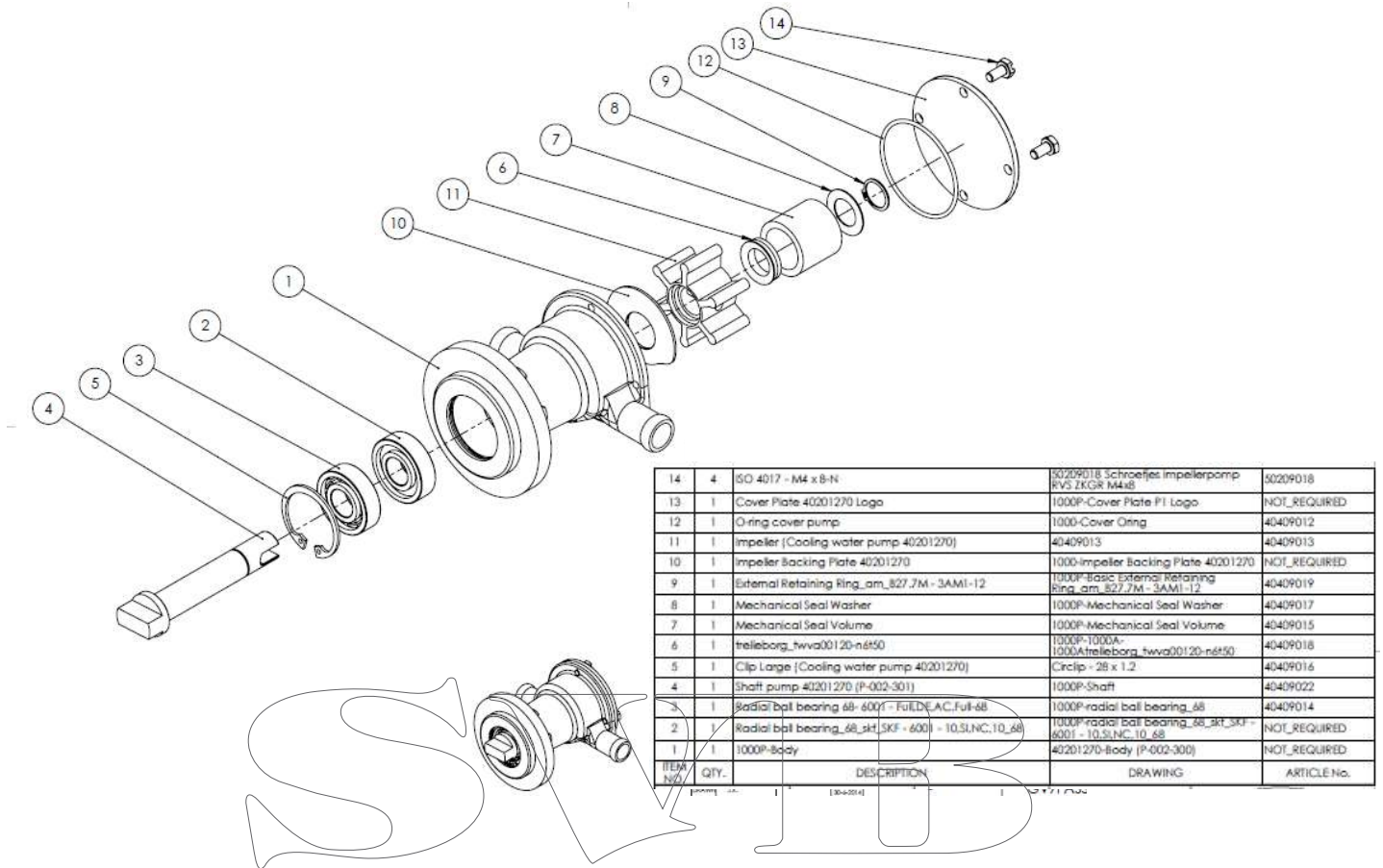

6.5 Warnings



Genverter must be shut off immediately if:

- unusual noise comes from Genverter.
- exhaust gases suddenly color dark.
- engine failure warning light is on.

6.6 Service address

If you cannot correct a problem with the aid of the trouble shooting tables, contact your WhisperPower Service Centre or WhisperPower Netherlands for an extended service list,

Tel: INT +31-512-571555.
7x24 Hr service.

7 SPARE PARTS LIST

We recommend the following spares for service and maintenance.

- Kit A: parts for regular maintenance parts marked (*) article no. 40401170
- Kit B: parts for maintenance + spare parts: all parts marked (*)+(**) article no. 40401171

ARTICLE NO	DESCRIPTION
40209030	Fuel filter (*)
50201160	Fuel lift pump (**)
40401329	Air filter element(*)
40401340	Oil strainer (**)
50209236	Lube oil pressure switch
50209239	Cooling oil pressure switch (**)
50209219	Temperature sensor (**)
40401101	Battery charger
40401062	PCB Local control panel
40401150	Digital Diesel Control unit
40209102	Digital Diesel remote control panel
50212171	Fuses 15 Amps (*)
50212170	Fuses 10 Amps (*)
50212155	Fuses 5 Amps (*)
50212154	Fuses 3 Amps (*)
40401060	Wiring loom
50209136	Remote control cable, 10 m, including connectors
40401279	Valve cover gasket (*)
40401221	Cylinder head gasket
40401392	Cylinder head gasket kit
40401391	Sealing ring / seal kit (**)
40401020	Actuator assembly /w brass spindle (**)
40401385	Injector assembly (**)
40401381	Fuel pump (high pressure), complete
40401240	Fuel pump solenoid (**)
40401386	Starter motor 12V
40201270	Raw water pump (complete, refer to section 6.2.3)
40209011	Kit: impeller (50209013) + gasket (50209012) (*) (refer to section 6.2.3)
40201029	Cover type K (**)
50209018	Cover bolts (**) (6PC)
50201251	Pump repair kit A consisting of: Shaft (50201011), Bearings (2 pcs.) (50209014), O-ring (50209017), Seals (2 pcs.) (50209015), Clips (1 set) (2x 50209019, 1x 50209016)
50209010	Pump repair kit B (**)(same as repair kit A except for the shaft)
40401029	Oil cooler and all fittings (***)
40401018	Oil pipes and fittings (***)
40401024	Water hoses and clamps (***)
40401031	Fuel hose kit

More extensive parts list on the internet: WWW.WHISPERPOWER.COM (fast moving parts)

8 MAINTENANCE LOG

Maintenance log	Wartungslogbuch	Journal de maintenance
This log must remain with the generator. In the event of a warranty claim, a copy of this log has to be sent to the manufacturer.	Dieses Logbuch verbleibt an Bord. Im Falle eines Garantieanspruchs muss eine Kopie an den Hersteller geschickt werden.	Ce journal demeure à bord. En cas de prétention à garantie, une copie est à dresser au fabricant.

	Inspection required at: Vorgesehen bei: Inspection exigée après:	Service level: Inspektionskategorie: Catégorie d'inspection:	Hours on indicator: Stand Betriebsstundenzähler: État du compteur d'heures:	Inspected by: Prüfer: Contrôleur:	Date: Datum:	*) Seal, stamp & full address of responsible WhisperPower Service Center (only applicable to items marked <input type="checkbox"/>) *) Stempel bzw. volle Adresse der Whisperpower Servicefirma (nur für mit <input type="checkbox"/> markierten Servicearbeiten) *) Cachet et adresse complète du centre de services WhisperPower (seulement pour les travaux marqués <input type="checkbox"/>).
01	35 - 50 h	break-in				
02	200 h	1				
03	400 h	1,2				
04	600 h	1				
05	800 h	1,2,3				
06	1000 h	1				
07	1200 h	1,2				
08	1400 h	1				
09	1600 h	1,2,3,4				*)
10	1800 h	1				
11	2000 h	1,2				
12	2200 h	1				
13	2400 h	1,2,3				
14	2600	1				
15	2800 h	1,2				
16	3000 h	1				
13	3200 h	1,2,3,4				*)
14	3400 h	1				
15	3600 h	1,2				
16	3800 h	1				
17	4000 h	1,2,3				

	Inspection required at: Vorgesehen bei: Inspection exigée après:	Service level: Inspektionskategorie: Catégorie d'inspection:	Hours on indicator: Stand Betriebsstundenzähler: Etat du compteur d'heures:	Inspected by: Prüfer: Contrôleur:	Date: Datum:	*) Seal, stamp & full address of responsible WhisperPower Service Center (only applicable to items marked <input type="checkbox"/>) *) Stempel bzw. volle Adresse der Whisperpower Servicefirma (nur für mit <input type="checkbox"/> markierten Servicearbeiten) *) Cachet et adresse complète du centre de services WhisperPower (seulement pour les travaux marqués <input type="checkbox"/>).
18	4200 h	1				
19	4400 h	1,2				
20	4600 h	1				
21	4800 h	1,2,3,4				*)
22	5000 h	1				
23	5200 h	1,2				
24	5400 h	1				
25	5600 h	1,2,3				
26	5800 h	1				
27	6000 h	1,2				
28	6200 h	1				
29	6400 h	1,2,3,4				*)
30	6600 h	1				
31	6800 h	1,2				
32	7000 h	1				
33	7200 h	1,2,3				
34	7400 h	1				
35	7600 h	1,2				
36	7800 h	1				
37	8000 h	1,2,3,4				*)
38	8200 h	1				
39	8400 h	1,2				
40	8600 h	1				
41	8800 h	1,2,3				
42	9000 h	1				

Supplier's Declaration of Conformity/Incorporation

In accordance with EN ISO 17050-1:2004

WhisperPower Genverter models M-GV4

No. 41002005, 41002006, 41002055, 41002065, 49002005, 49002006

Issuer's name: WhisperPower BV

Issuer's address: Kelvinlaan 82, NL-9207 JB Drachten

Object of the declaration:

The object of the declaration described above is in conformity with the requirements of the following Directives and standards, as applicable:

<i>Document</i>	<i>Title</i>
2004/108/EC	Electromagnetic Compatibility Directive
EN 61000-3-2:2014	Electromagnetic compatibility (EMC) - Part 3-2: Limits - Limits for harmonic current emissions (equipment input current ≤ 16 A per phase)
EN61000-6-1: 2007	Electromagnetic compatibility (EMC) - Part 6-1: Generic standards - Immunity for residential, commercial and light-industrial environments
EN 61000-6-2: 2007	Electromagnetic compatibility (EMC) -- Part 6-2: Generic standards - Immunity for industrial environments
EN 61000-6-3: 2007+A1:2011	Electromagnetic compatibility (EMC) -- Part 6-3: Generic standards - Emission standard for residential, commercial and light-industrial environments
2006/95/EC	Low Voltage Directive
EN 60950:2000	Safety of information technology equipment
2004/26/EC	Non-Road Mobile Machinery Exhaust Emissions Directive
2006/42/EC	Machinery Directive
EN 842:1996+A1:2008	Safety of machinery - Visual danger signals - General requirements, design and testing
ISO 12100:2010	Safety of machinery - General principles for design - Risk assessment and risk reduction

The machinery is incomplete and must not be put into service until the machinery into which it is to be incorporated or the vessel into which it is to be installed, has been declared in conformity with the provisions of the Directive.

We undertake to transmit, in response to a reasoned request by the appropriate national authorities, relevant information on the partly completed machinery identified above.

Signed for and on behalf of:

WhisperPower BV

M. Favot,
Chief Technical Officer,

Drachten, November 10, 2014

The technical documentation for the machinery is available from:
WhisperPower BV, Kelvinlaan 82, 9207 JB Drachten, Netherlands

SWIB



Kelvinlaan 82, 9207 JB Drachten, Netherlands

Tel : + 31-512-571550 / Fax : + 31-512-571599

www.whisperpower.com / info@whisperpower.com