

CONTENTS:

1.	SAFETY PRECAUTION AND PROCEDURES.....	3
1.1	BEFORE USE.....	4
1.2	DURING USE.....	5
1.3	AFTER USE.....	5
2.	GENERAL.....	6
3.	FEATURES AND SPECIFICATIONS.....	6
3.1	MAIN FEATURES.....	6
3.2	GENERAL SPECIFICATIONS.....	7
3.3	OPERATION CONDITIONS.....	7
3.4	TECHINICAL SPECIFICATIONS.....	8
4.	OPERATING INSTRUCTIONS.....	10
4.1.	INSTRUMENT DESCRIPTION.....	10
4.1.1	FRONT PANEL DESCRIPTION.....	10
4.1.2	REAR PANEL DESCRIPTION.....	13
5.	POWER SUPPLY DESCRIPTION.....	14
5.1.	SETTING THE OUTPUT VOLTAGE.....	14.
5.2.	SETTING THE OUTPUT CURRENT.....	16
5.3	FIXED 5V/1A OUTPUT (FOR GRADE C MODEL ONL Y).....	18
6.	FUSE REPLACEMENT.....	24
7.	PACKAGE.....	25
8.	TROUBLESHOOTING.....	26
9.	SERVICE.....	26
9.1.	WARRANTY CONDITIONS.....	26
9.2.	SERVICING.....	27

1. SAFETY PRECAUTION AND PROCEDURES

The instrument is designed and tested in accordance with EN publication 61558-2-6:11.97. The instrument has been tested in accordance to the following EC Directives(EMC):

- a. EN61204-3:12.2000
- b. EN61000-3-2:04.95+A1:1998+A2:1998+A14:2000
- c. EN61000-3-3:01.95

The instrument complies with the requirements of the European Council Directive 89/336/EEC(EMC Directive)and 73/23/EEC(Low Voltage Directive).

To ensure that the instrument is used safely, follow all safety and operating Instructions in this manual . If the instrument is not used as described in this manual, the safety features might be impaired

WARNING

Non compliance with the warnings and/or the instructions for use may damage the instrument and/or its components or injure the operator.

Take extreme care under the following conditions when using the instrument:

- For your own safety and that of the instrument ,you must follow the procedure described in this instruction manual.
- Do not use this instrument in a location where there is explosive gas in the vicinity. The use of this instrument in a location where there is explosive gas could result in explosion.
- If there is any smoke, abnormal odor , or abnormal sound coming from this instrument, immediately switch off the power and disconnect the power cord. Continuous using of this instrument under these conditions could result in electrical shock or fire . After disconnecting the power cord, contact the service offices for repair by the user is dangerous and should be strictly avoided.
- Take care not to allow water to get into this instrument .The use of this instrument in a wet state could result in electrical shock or fire. If water or other foreign matter has penetrated this instrument , switch the power off ,then remove the power card and call for repair.
- Do not place this instrument on an unstable or slanting surface. The dropping or turning over this instrument could result in electrical shock, injury or fire. If this instrument has been dropped or its cover has damaged, switch the power off, remove the power cord and call for repair.
- Do not allow any foreign matter such as metal or inflammable substance to get into the instrument via the air holes . The penetration of any foreign matter from the ventilation holes could result in fire . electrical shock ,or power failure.
- Use this instrument with the rated AC power sources . Use of this instrument with a voltage other than specified could result in electrical shock ,fire or power failure. The usable power voltage range is marked on the rear panel.
- Do not remove either the cover or panel.

- **Do not modify this instrument.**
- **Avoid use of damaged cables.**

1.1. BEFORE USE

1. **Make sure the POWER switch is pressed and connect the power cord to the power supply.**
2. **Our PSM series is a dynamic type power supply . The user can ground the output terminal by using the ground plate between the ground (GND)and cathode(-)or the ground(GND)and anode(+).**
3. **To set the constant voltage output: Power on the power supply . Adjust the VOLTAGE tune knob for adjustment . Once the voltage or current value is reached, the desired value will appear on the Display Panel.**

1.2 DURING USE

1. **Ensure the voltage and current is set to zero ,prevent a undesired output for damaging the circuit .**
2. **The supplied voltage should be within 110V AC or 220V AC \pm 10%(50Hz) and the system is capable for supplying the maximum power consumption as indicated on section 3.3.**
3. **keep a distance at least greater than 10cm between the power supply and other things for airy reason when usage . Do not place this power supply in a hot , dusty . wet, corrosive gas stage or near the poison substance.**
4. **The power supply needed warm up for 30 minutes , to meet the specification. Section 3.4.**
5. **keep hands and face away from the ventilation fan.**
6. **Do not touch the rear panel during operation.**

1.3. AFTER USE

1. **Once the operation completed, remove all connections from the power supply ,especially the power source.**
2. **Wait for the power supply to cool down.**
3. **Store in a dry , well air and non-dusty environment.**

2. GENERAL

PSM series is a high performance and precision multi channels DC regulated power supply up to 4-channel outputs. Our PSM series has constant voltage mode , constant current mode ,auto current cut off protection function, overload protection and auto tracking mode .In auto tracking mode ,PSM series can auto connect CH1 and CH2 output either in parallel or in series intermally to provide double current or voltage output.

Our PSM4 series provide 4 channels adjustable outputs . Our PSM3 series provide 2 channels adjustable output and one fixed 5v/1a output. Our PSM2 series provide 2 channels adjustable output .All adjustable outputs voltage and current value can be adjusted linearly.

With the extract stability and enhanced responsibility ,this power supply is suitable for bench , laboratory ,university, high school , and enterprise use or where needed a high performance and precision regulated DC power supply.

3. FEATURES AND SPECIFICATIONS

MAIN FEATURES

- 2 Adjustable Channels Output (RS2 series)
- 3 Adjustable Channels Output (RS3 series)
- 4 Adjustable Channels Output (RS4 series)
- 0-30V Linear Voltage and Current Output Display
- 4 Sets of LED for Voltage and Current Output Display
- Low Noise and Ripple ; Less than 1mV(5Hz-1mHz)
- Voltage and Current Pre-set Feature
- Current Output Protection
- CV/CC Mode Automatic Changer
- Auto Tracking Output
- Auto Parallel or Series connection
- Doubling Current with Series connection
- Doubling Voltage with Parallel connection
- 16 Hours Continuous Operation with Full Loading
- Rugged Metal Cabinet

3.2. GENERAL SPECIFICATIONS

Mode I	No. of Channels	CHANNEL OUTPUT							
		CH1		CH2		CH3		CH4	
		Voltage	Current	Voltage	Current	Voltage	Current	Voltage	Current
RS13 22	2	0~30v	2A	0 ~ 30V	2A	N/A			
RS13 23	2		3A		3A				
RS13 25	2		5A		5A				
RS13 32	3	0~30v	2A	0 ~ 30V	2A	5V	1A	N/A	
RS13 33	3		3A		3A				
RS13 35	3		5A		5A				
RS13 42	4	0~30v	2A	0 ~ 30V	2A	2.2 ~ 5.2V	1A	8~15V	1A
RS13 43	4		3A		3A				
RS13 45	4		5A		5A				

3.3. OPERATION CONDITIONS

Environmental Condition	Operating altitude <2000m.pollution degree II
-------------------------	---

Input Voltage	110VAC/220VAC±10% at 50/60Hz		
Fuse Protection: (Fuse Blow Type)		220V	110V
	RS2	T2A/250V	T6A/250V
	RS3	T3A/250V	T6A/250V
	RS4	T4A/250V	T6A/250V
Power Consumption:	5A output model		600 W
	3A output model		380 W
	2A output model		260 W
Operating Condition	Temperature		0 ~ 40°C
	Relative Humidity		≤80%RH
Storage Condition	Temperature		-1°C ~ 70°C
	Relative Humidity		≤80%RH

3.4. TECHNICAL SPECIFICATIONS

Channel 1 and 2 Characteristic	
Constant Voltage Mode (CV)	
Voltage Range	0 to maximum rated current
Line Effect	$\leq 1 \times 10^{-4} + 3\text{mV}$ (±10% of Rated Voltage)
Loading Effect	$\leq 1 \times 10^{-4} + 3\text{mV}$ (output current $\leq 3\text{A}$) $\leq 2 \times 10^{-4} + 3\text{mV}$ (output current $\geq 3\text{A}$)
Noise and Ripple	$\leq 1\text{mVrms}$ (5Hz-1MHz)
Recovery Time	$\leq 100\text{usec}$ (50% of loading effect with min. loading of 0.5A)
Temperature Coefficient	$\leq 300\text{ppm}/^\circ\text{C}$
Constant Current Mode (CC)	
Current Range	0 to maximum rated current
Line Effect	$\leq 2 \times 10^{-3} + 3\text{mA}$
Loading Effect	$\leq 2 \times 10^{-3} + 3\text{mA}$
Noise and Ripple	$\leq 3\text{mAms}$
Tracking Characteristic (in Series)	
Line Effect	$\leq 1 \times 10^{-4} + 3\text{mV}$
Loading Effect	$\leq 1 \times 10^{-4} + 3\text{mV}$ (Output current $\leq 3\text{A}$) $\leq 2 \times 10^{-4} + 3\text{mV}$ (Output current $\geq 3\text{A}$)
Tracking Characteristic (in Parallel)	
Line Effect	$\leq 1 \times 10^{-4} + 5\text{mV}$
Loading Effect	$\leq 300\text{mV}$
RS4 Channel 3 Characteristic	
Voltage Range	2.2-5.2V (±8%)
Current Range	0-1A

Line Effect	$\leq 5\text{mV}$
Loading Effect	$\leq 15\text{mV}$
Noise and Ripple	$\leq 2\text{mVrms (5Hz-1MHz)}$
RS4 Channel 4 Characteristic	
Voltage Range	8-15V ($\pm 8\%$)
Current Range	0-1A
Line Effect	$\leq 5\text{mV}$
Loading Effect	$\leq 15\text{mV}$
Noise and Ripple	$\leq 2\text{mVrms (5Hz-1MHz)}$
PSM3 Channel 3 Characteristic	
Voltage Range	5.0V ($\pm 8\%$)
Current Range	Fixed 1A
Line Effect	$\leq 5\text{mV}$
Loading Effect	$\leq 15\text{mV}$
Noise and Ripple	$\leq 2\text{mVrms (5Hz-1MHz)}$
Display Accuracy	
Digital Display	3 Digital Display ($\pm 0.5\%+2d$)
Insulation	
Chassis and Terminal	$\leq 20\text{M}\Omega$, at DC500V
Chassis and Power Cord	$\leq 30\text{M}\Omega$, at DC500V
Mechanical Specification	
Weight (kg):	7.5 approximately
Dimension (mm):	255X150X305

4. OPERATING INSTRUCTIONS

4.1. INSTRUMENT DESCRIPTION

4.1.1. Front panel description

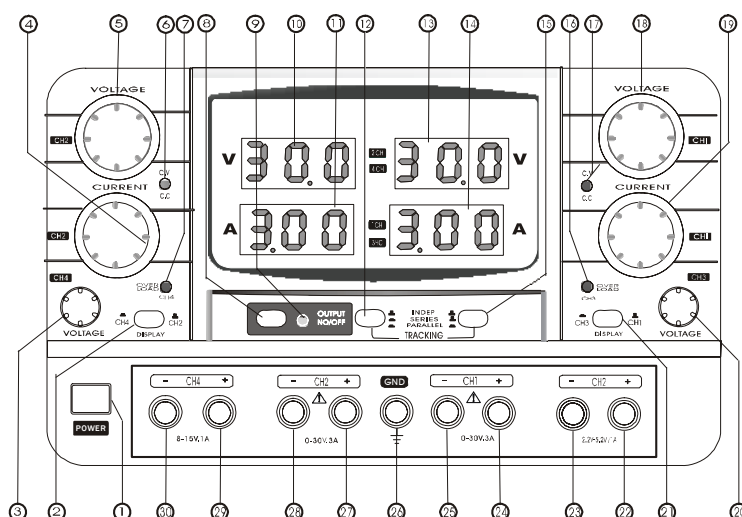

Legend:

Item	Description
1	POWER SWITCH: Press it to power on/off the power supply
2	CH2/CH4 DISPLAY SWITCH: PRESS it to select display CH4 Voltage/current value or release to release to select display

	CH2 voltage/current value.
3	CH4 VOLTAGE tune knob (for PSM4 model):turn clockwise for increasing the voltage value; turn anti-clockwise for decreasing the voltage value.
4	CH2 CURRENT tune knob: Turn clockwise for increasing the current value; turn anti-clockwise for decreasing the voltage value.
5	CH2 VOLTAGE tune knob: Turn clockwise for increasing the voltage value; turn anti-clockwise for decreasing the voltage value.
6	CH2 CV/CC(CONSTANT VOLTAGE/CURRENT MODE) INDICATOR: When CH2 is at the constant voltage mode, this LED light will be on as green colour. When CH2 is at the current mode and in Parallel Tracking Mode ,this LED light will be on as red colour.
7	CH4 OVERLOAD INDICATOR (for psm4 model):When CH4is at the constant current mode this LED light will be on.
8	AUTO CURRENT CUT OFF PROTECTION KEY: After power ON .the power supply will at protection state (no voltage output at all terminals and OUTPUT indicator [9] is OFF);however, the voltage DISPLAY. Panel [10,11]will still show the pre-set voltage value .When the Auto Current Cut off protection key is pressed, all terminals will output the voltage as indicated on the voltage display panel and the OUTPUT indicator [9]is ON. repress the key to cut off the output again .After cut off, it takes 3 seconds interval to return normal.
9	OUTPUT INDICATOR: see [8]
10	CH2/CH4 VOLTAGE DISPLAY PANEL: This display will indicate CH2 or CH4 voltage value that will be applied to the circuit
11	CH1/CH3 VOLTAGE DISPLAY PANEL: This display will indicate CH1 or CH3 voltage value that will be applied to the circuit
12	TRACKING MODE SELECTION KEY: this key is operated with key [5],to select INDEPENDENT MODE, SERIES TRACKING MODE and PARALLEL TRACKING MODE for CH1and CH2 output. a) To select INDEPENDENT MODE: Release these two keys;CH1and CH2 will operate separately. b) To select SERIES TRACKING MODE : press Key [12] and release key [15], CH2 output voltage will be followed by CH1, connect the circuit to CH1 “+” terminal and CH2 “-“terminal to get double rated voltage output. c) To select PARALLEL TRACKING MODE : Press both Key [12] and key [15], CH2 output voltage and current will be followed by CH1, parallel connect the circuit to CH1 output will get 0-30v and double rated current output.
13	CH2/CH4 CURRENT DISPLAY PANEL: This display will indicate CH2 or CH4 current value that will be applied to the circuit
14	CH1/CH3 CURRENT DISPLAY PANEL: This display will indicate CH1 or CH3 current value that will be applied to the circuit
15	TRACKING MODE SELECTION KEY: see [12]
16	CH3 OVERLOAD INDICATOR (for PSM4 model): When CH3 is at the constant current mode this LED light will be on.

17	CH1 CV/CC (CONSTANT VOLTAGE/CURRENT MODE) INDICATOR: When CH1 is at the constant voltage mode, this LED light will be on as green colour. When CH1 is at the current mode and in Parallel Tracking Mode, this LED light will be on as red colour.
18	CH2 VOLTAGE tune knob: Turn clockwise for increasing the voltage value; turn anti-clockwise for decreasing the voltage value. When in SERIES/PARALLEL TRACKING MODE, use this knob to adjust CH2 voltage.
19	CH1 CURRENT tune knob: Turn clockwise for increasing the current value; turn anti-clockwise for decreasing the current value. When in SERIES/PARALLEL TRACKING MODE, use this knob to adjust CH2 current.
20	CH3 VOLTAGE tune knob (for PSM4 model): Turn clockwise for increasing the voltage value; turn anti-clockwise for decreasing the voltage value.
21	CH1/CH3 DISPLAY SWITCH: PRESS it to select display CH3 Voltage/current value or release to select display CH1 voltage/current value.
22	CH3 “+”TERMINAL: Positive terminal of 2.2–5.2v adjustable output (for PSM4 model) or fixed 5v output (for PSM3 model).
23	CH3 “-” TERMINAL: Negative terminal of 2.2–5.2v adjustable output (for PSM4 model) or fixed 5v output (for PSM3 model).
24	CH1 “+”TERMINAL: Positive terminal of 0–30v adjustable output.
25	CH1 “-”TERMINAL: Negative terminal of 0–30v adjustable output.
26	GND grounding terminal: This terminal is connecting to the casing and the Earth.
27	CH2 “+”TERMINAL: Positive terminal of 0–30v adjustable output.
28	CH2 “-”TERMINAL: Negative terminal of 0–30v adjustable output.
29	CH4 “+”TERMINAL: Positive terminal of 8–15v adjustable output. (for PSM4 model).
30	CH4 “-”TERMINAL: Negative terminal of 8–15v adjustable output. (for PSM4 model).

4.1.2 Rear panel description

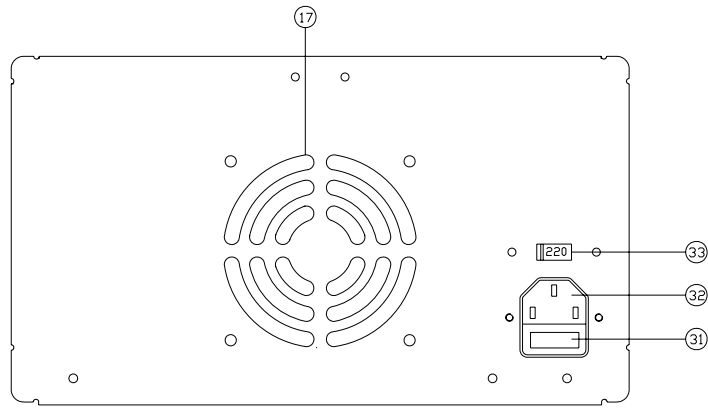

Legend:

ITEMS	Description
31	FUSE SOCKET: Use suitable fuse which is stated in Section 3.3
32	POWER INPUT SOCKET : Input AC220V/AC110V $\pm 10\%$ 50/60Hz
33	INPUT VOLTAGE SELECTOR : For 110V AC power system, please switch the INPUT VOLTAGE SELECTOR switch to the top for 110v AC power system selection. For 220V AC power system, please switch the INPUT VOLTAGE SELECTOR switch to the top for 220v AC power system selection.
34	VENTILATION FAN: This fan is used to exhaust heat air from internal heat sink.

5. POWER SUPPLY DESCRIPTION

5.1 SETTING THE CH1 AND CH2 OUTPUT VOLTAGE

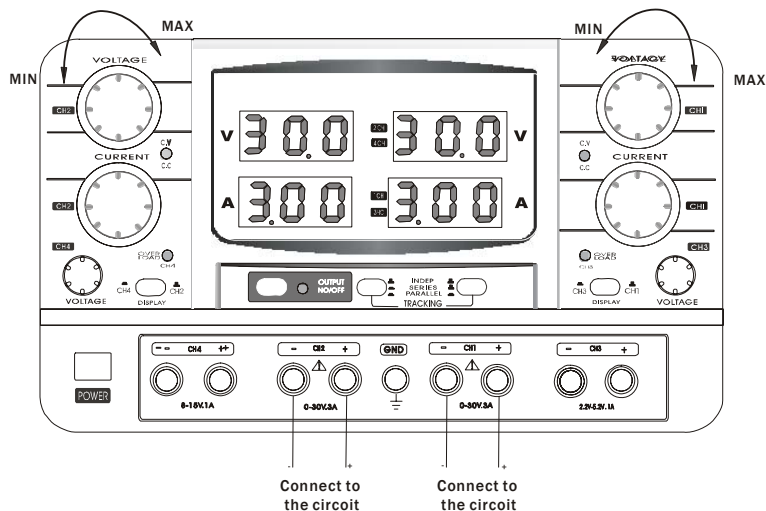

1. Connect the power supply to the power source.
2. Press the **POWER SWITCH [1]** to turn on the power supply.
3. To setting CH1, use the **CH1 VOLTAGE TUNE KNOB [18]** to adjust **CH1** voltage to give a desired output voltage.
4. Connect the circuit to the **TERMINALS [24, 25]**
5. Press **AUTO CURRENT CUT OFF PROTECTION KEY [8]** to activate output and the **OUTPUT INDICATOR [9]** will on.
6. When the **CH1 CV/CC INDICATOR [17]** is in red colour , adjust the **CH1 CURRENT TUNE KNOB[19]** to give a suitable current.
7. To setting CH2 voltage , repeat the above steps , use **CH2 VOLTAGE TUNE KNOB [5]**, short **MAIN TERMINAL [26, 27]** and **CH2 CV/CC INDICATOR [6]** instead.

Remarks:

1. If CH2 cannot be adjusted , check the **TRACKING MODE SELECTION KEY [12, 15]** is not pressed.
2. If want to preset a desired current output before connecting to the circuit , read Section 5.2 first.

Caution:

- Make sure the **INPUT VOLTAGE SELECTOR [33]** set to a correct position Otherwise , it will damage the power supply.
- Do not short the **MAIN TERMINALS** over 1 minute; it will damage the power supply.

5.2. SETTING THE CH1 OR CH2 OUTPUT CURRENT

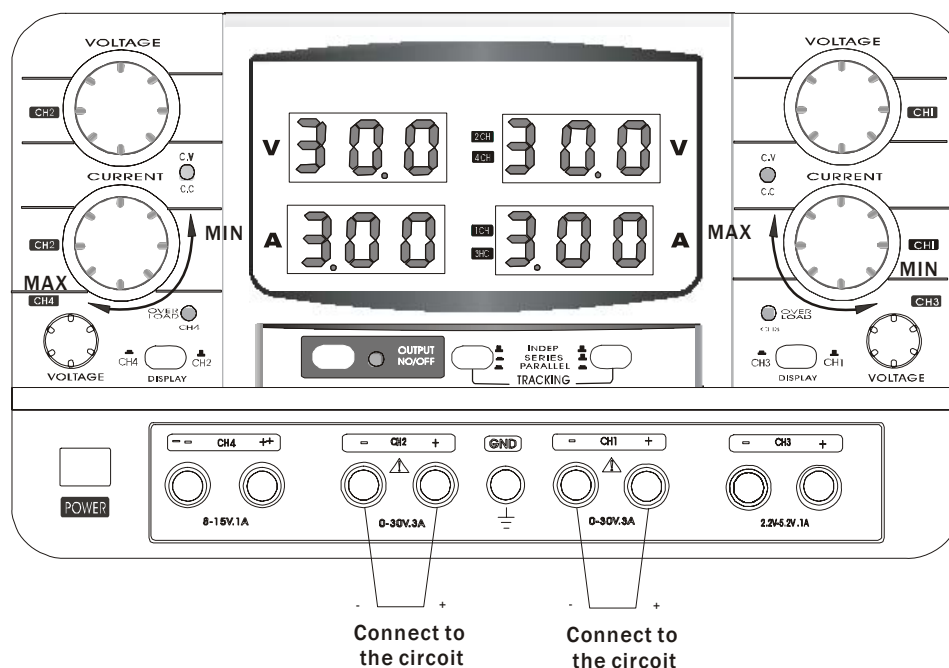

1. Turn to the power supply
2. Refer to Section 5.1 step 1-4 to give the voltage around 2-5V
3. For CH1, turn the **CH1 CURRENT TUNE KNOB [19]** anticlockwise reach the minimum current value.
4. Short the + and the - **MAIN TERMINAL [24, 25]** with a conductor which is cross section area not less than 0.5mm^2 .
5. Ensure the output indicator is on. Otherwise, press the **AUTO CURRENT CUT OFF PROTECTION KEY [8]**. Then the **CH1 CV/CC INDICATOR [17]** will turn to red colour.
6. Adjust the **CH1 CURRENT KNOB [19]** to give a desired output current.
7. Repress the **AUTO CURRENT CUT OFF PROTECTION KEY [8]** to Cut off the output.
8. Then the **CH1 CV/CC INDICATOR [17]** will turn to green colour.
9. Remove the conductor the **MAIN TERMINA [24, 25]**
10. Set to desired voltage.
11. Connect the circuit to the **MAIN TERMINA [24, 25]**
12. To setting CH2 current, repeat the above steps, use **CH2 CURRENT TUNE KNOB [4]**, short **MAIN TERMINAL [26, 27]** and **CH2 CV/CC INDICATOR [6]** instead.

Remarks:

- The conductor is not provided

Caution:

- Ensure the current is set to zero before shorting the **MAIN TERMINALS**. Otherwise it will damage the power supply.
- Do not short the **MAIN TERMINALS** over 1 minute; it will damage the power supply.

5.3. SETTING CH3 VOLTAGE OUTPUT (FOR RS3 AND RS4 ONLY)

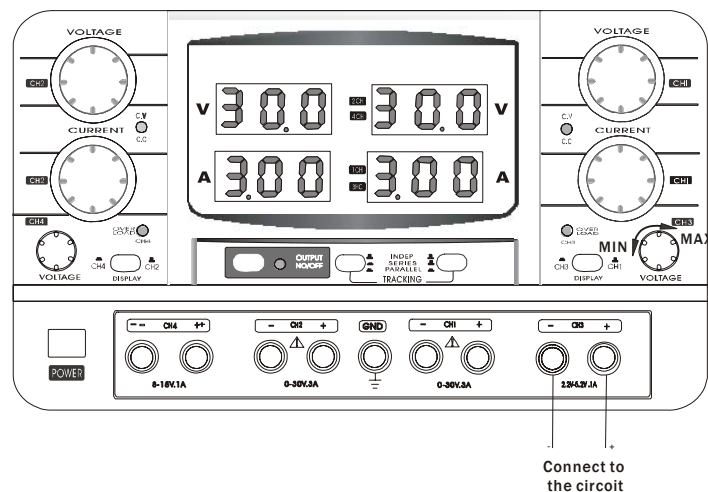

1. Connect the power supply to the power source.
2. Press the **POWER SWITCH [1]** to turn on the power supply
3. Press **CH1/CH3 DISPLAY SWITCH [21]** to select display CH3

voltage and current value . When display CH3 value , the “CH3” icon will on .

4. Use the CH3 VOLTAGE KNOB [20] to adjust CH3 voltage to give a desired output voltage.
5. Connect the circuit to the CH3 TERMINAL [22, 23].
6. Press AUTO CURRENT CUT OFF PROTECTION KEY [8] to activate output and the OUTPUT INDICATOR [9] will on.
7. When the CH3 OVERLOAD INDICATOR [16] is on , remove some loading on the terminal to reduce current consumption.

Remarks:

- Current output is fixed to 1A, not adjustable.

Caution:

- Make sure the INPUT VOLTAGE SELECTOR [33] set to a correct position Otherwise , it will damage the power supply.
- Do not short the MAIN TERMINALS over 1 minute; it will damage the power supply.

5. 4. SETTING CH4 VOLTAGE OUTPUT (FOR PSM4 ONLY)

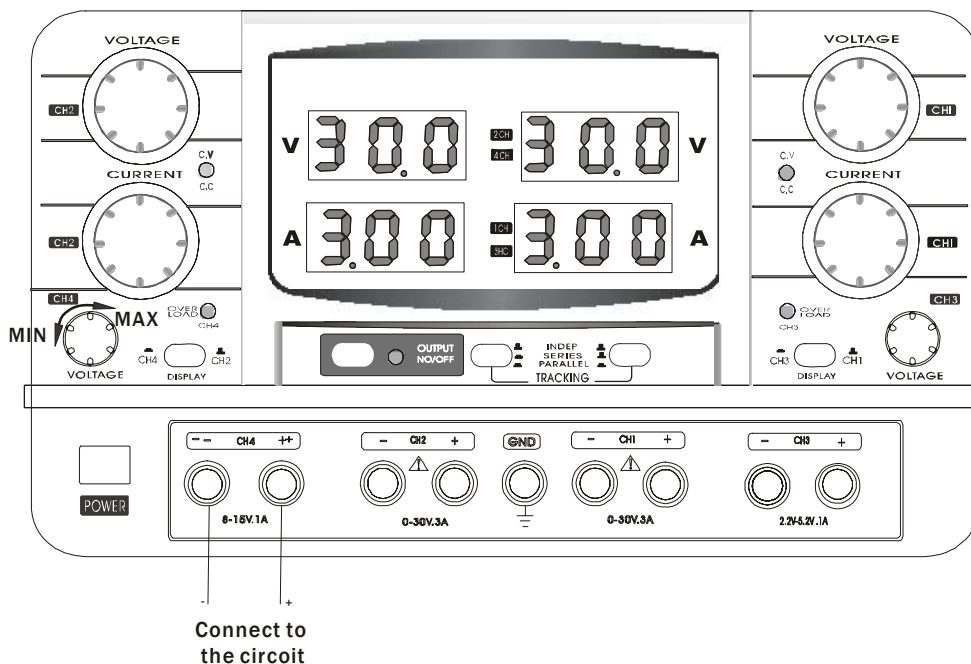

1. Connect the power supply to the power source.
2. Press the POWER SWITCH [1] to turn on the power supply
3. Press CH2/CH4 DISPLAY SWITCH [2] to select display CH4 voltage and current value . When display CH4 value , the “CH4” icon will on .
4. Use the CH4 VOLTAGE KNOB [3] to adjust CH4 voltage to give a desired output voltage.
5. Connect the circuit to the CH4 TERMINAL [29, 30].

6. Press AUTO CURRENT CUT OFF PROTECTION KEY [8] to activate output and the OUTPUT INDICATOR [9] will on.
7. When the CH4 OVERLOAD INDICATOR [7] is on ,remove some loading on the terminal to reduce current consumption.

Remarks:

- Current output is fixed to 1A, not adjustable.

Caution:

- Make sure the INPUT VOLTAGE SELECTOR [33] set to a correct position Otherwise , it will damage the power supply.
- Do not short the MAIN TERMINALS over 1 minute; it will damage the power supply.

5.5. SETTING INDEPENDENT MODE

1. Release both TRACKING MODE SLECTION KEY [12, 15].
2. In independent mode ,CH1 and CH2 is two independent power supply unit ,voltage or current can be adjusted separately.
3. Adjust CH1 or CH2 VOLTAGE/CURRENT KNOB [19, 20/4, 5] to set the desired value.
4. Connect the circuit to the CH1 or CH2 terminals.

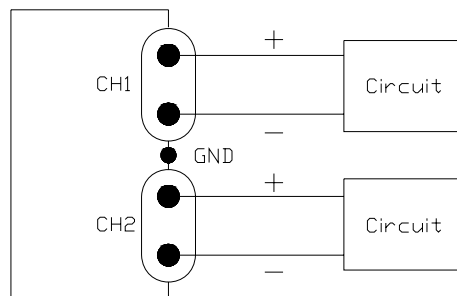

Regulated
DC Power Supply
Illustration of independent mode

5.6. SETTING SERIES TRACKING MODE

1. Press TRACKING MODE SLECTION KEY [12] and release TRACKING MODE SLECTION KEY [15] to enable series tracking mode .In series tracking mode ,CH2 output voltage and current value follows CH1 setting. The output voltage is double to the CH1 display value.

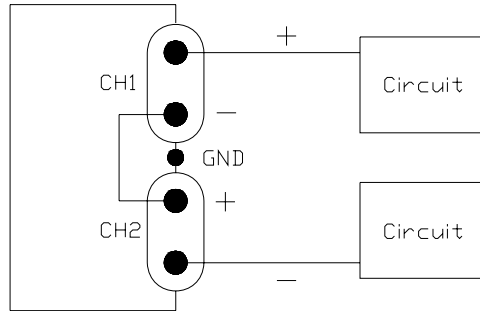

Regulated
DC Power Supply
Illustration of series tracking mode

2. Turn CH2 CURRENT KNOB[4] clockwise to maximum current output, and then use CH1 CURRENT KNOB[19] adjust the desired current output value. (Reference to Section 5.2)
3. Use CH1 VOLTAGE KNOB [18] to adjust the desired voltage output value.
4. Connect the circuit to the CH1 “+”TERMINAL[24] and CH2“-”TERMINAL[28] to get double voltage output.
5. For the bi-polar DC power supply with common ground, connect CH2 “+” TERMINAL[27] to “GND” GROUNDING TERMINAL [26]. CH1 “+”TERMINAL[24] is the positive output and CH2 “-”TERMINAL[28] is the negative output.

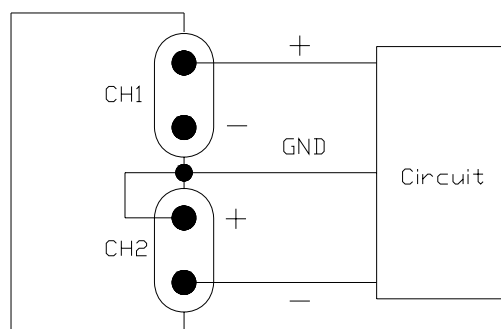

Regulated
DC Power Supply
Illustration of Bi-Polar Tracking Mode

SETTING PARALLEL TRACKING MODE

1. Press both TRACKING MODE SLECTION KEY[12, 15] to enable parallel tracking mode . In parallel tracking mode , CH2

output voltage and current value follows CH1 setting.
The output current is double to the CH1 display value.

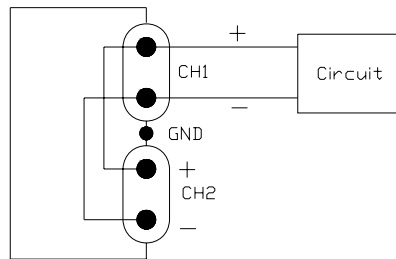

Regulated
DC Power Supply
Illustration of Parallel Tracking Mode

2. Use CH1 VOLTAGE KNOB [18] to adjust the desired voltage output value.
3. CH1 CURRENT KNOB[19] adjust the desired current output value. (Reference to Section 5.2)
4. Connect the circuit to the CH1 TERMINAL [24, 25] to get double current output.

5.8 FUSE REPLACEMENT

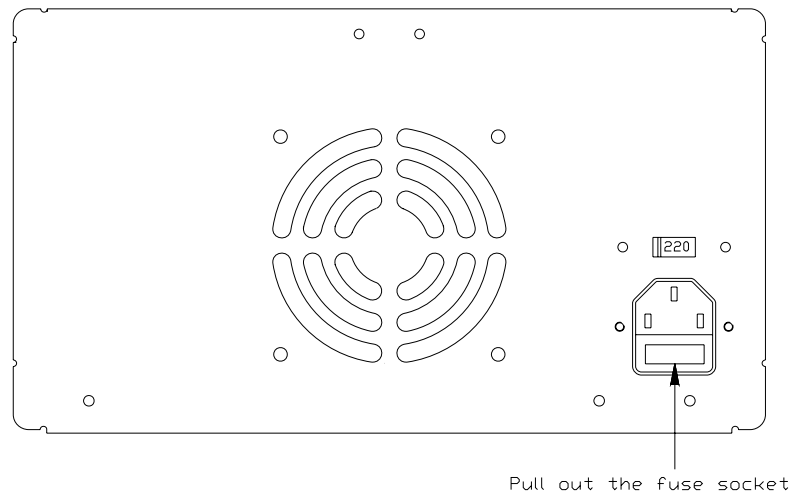

1. Disconnect all power connection.
2. Locate the fuse socket at the rear panel power socket.
3. Pull out the fuse socket from the power socket.
Replace the fuse with identical rating .Refer to section 3.3
4. Reinstall the fuse socket. (Re-push the fuse socket to

the power socket.

Caution:

- Ensure no power is connected to the power supply ; otherwise , electrical shock may occur.
- Do not over push the fuse socket , or the fuse socket may be damaged.

6. PACKAGE

1. Power supply
2. power cord
3. Instruction manual
4. Main connection cable
 - RS4:4 cables
 - RS4:3 cables
 - RS4:2 cables

7. TROUBLESHOOTNG

Problem	Solution
The power supply cannot start up (NO DISPLAY)	<ol style="list-style-type: none">1. Ensure the power source or power cord is working properly2. Check the fuse . if the fuse broken , disconnect from the power source then replace with identical rated fuse.
While operating in the CV mode, the voltage suddenly drop down and the CC indicator turns	This power supply is current protected. The desired current range is under the circuit gain; therefore ,the power supply is switched to CC mode ,Adjust the current knob clockwise to increase the current range.
The power supply output unstable.	<ol style="list-style-type: none">1. The power supply needs at least 30minutes to warm up and reach the specification.2. The power source (voltage) is under the minimum requirement.

If the above solution cannot solve the problem ,please contact the local dealer , distributor or the manufacturer listed at the back.

8. SERVICE

WARRANTY CONDITIONS

This instrument is guaranteed against any material fault or manufacturer's defect ,in accordance with the general conditions of sale. During the warranty period (one year). faulty parts may be replaced ,with the manufacturer

reserving the right to decide either to repair or replace the product.

In the event of returning the instrument to the after-sales service or to a regional branch, the outward transport is payable by the customer. The delivery must be agreed in advance with consignee. For delivery indicate, by means of an enclosed note, as clear as possible, the reasons for returning. Use only the original packing. Any damage caused by shipment using NOT original packing will be charged in any case to the consignor.

The manufacturer will not be responsible for any damage to persons or things.

The warranty does not apply to the following cases:

- Accessories and fuse are not included in warranty.
- Repairs following unsuitable use of the instrument or by combining the latter with incompatible instrument.
- Repairs resulting from incorrect shipping.
- Repairs resulting from servicing carried out by a person not approved by the company.
- Modifications to the instrument without explicit authorization from our technical department.
- Adaptation to a particular application not provided for by the definition of the instrument or by the instruction manual.

The contents of this manual may not be reproduced in any form whatsoever without the manufacturer's authorization.

<p>This product has been patented/pending to be patented in many countries that it has been distributed. The logotypes are registered. We reserve the right to modify specifications and prices as part of technological developments, which might be necessary without prior notice.</p>

SERVICING

Before contact for Servicing, please check the power source and fuse (change them if necessary). If the power supply still does not work, check if your operating procedure agrees with the description in this manual. In the event of returning the power supply, it must be re-sent to the after-sales service (at address or to a regional branch), the outward transport is payable by the customer. The delivery must be agreed in advance with

consignee . For delivery indicate the reasons for returning it . (By means of an enclosed note, as clear as possible) use only the original packing . Any damage caused by delivery with NO original packing will be charged in any case to the consignor.