

CHAPTER 8

CALIBRATING AND MAINTAINING MULTIPROBE INSTRUMENTS

This chapter describes the calibration procedures for the most commonly used multiprobe instruments. Since the TCEQ and the CRP planning agencies use Hydrolab and YSI products, this section was written to address calibration and maintenance of those products. If another multiprobe instrument (for example, Greenspan, In-Situ) is being used, refer to the manufacturer's instruction manual. Such other instruments must meet the post-calibration error limits discussed in this chapter. The manufacturers' manuals also detail other instrument functions not described in this chapter, such as downloading data. For all instruments used, manufacturers' maintenance and calibration manuals must be kept for reference. All calibration and maintenance activities must be recorded in a *SWQM Multiprobe Calibration Logbook* or something similar (see Figures 8.3 and 8.4 for examples).

Calibrate parameters in the order given in this chapter and on the calibration log sheets—specific conductance, pH, and DO (see Figures 8.3 and 8.4).

Calibration Logbooks for SWQM

Each instrument must have its own logbook to facilitate efficient review of calibration and post-calibration results and maintenance procedures. The SWQM Program has developed logbooks for use with Hydrolab and YSI instruments; they are available upon request from the SWQM Program or the CRP. Both the Hydrolab and YSI calibration logbooks summarize the calibration procedures and contain a number of individual calibration log sheets. See Figures 8.3 and 8.4 for YSI and Hydrolab calibration log sheets. The calibration log sheets are also available on the Web (see Appendix A).

Keep full calibration logs on file for at least five years or as defined in a program or project QAPP.

The following is basic information to be recorded in a log for each calibration.

- The date, time, and the initials of the person performing the calibration.
- The name and model number of the instrument being calibrated.
- The battery voltage.
- Initial instrument readings during immersion in the calibration standard before calibration (temperature, value of standard, and initial reading).
- The *calibrated to* value obtained after adjusting the instrument to the calibration standard value.

As needed, the following information is recorded for each instrument.

- Factory maintenance, including the date shipped for any repairs, the date returned from repair, and a description of the repair work.

- In-house instrument maintenance, including the date and a description of any maintenance activity (for example, battery replacement, probe cleaning, membrane replacement, stirrer cleaning, reference-solution replacement).

Temperature-Controlled Environment

Take into consideration the environment in which the multiprobe instrument will be calibrated. It is very important that the standards, buffers, rinse waters, and the instrument itself be acclimated in a environment with stable temperature. Deionized (DI) water used for rinsing sensors should be stored in a large container in the room normally used for calibration. The temperature of tap water or DI water from a column used for rinsing is often very different from room temperature.

If the instrument, standards, buffers, and rinse water are transported to the field, and calibration or a post-calibration check away from the laboratory becomes necessary, make sure the instruments have acclimated to the same temperature. For example, place the solutions and instruments in a motel room in the evening and calibrate in the morning.

Rinsing the Sensors

It is very important to rinse with DI water between the calibration of specific conductance and pH.

- Unscrew the cap and remove it from the calibration cup.
- Fill the calibration cup about halfway with DI water.
- Place the cap on the calibration cup.
- Shake the sonde to rinse any contaminants that might interfere with calibration. Rinse with DI water at least twice.
- Repeat this procedure with the appropriate calibration standard. Rinse at least twice, discarding the rinse each time. Fill the calibration cup with the standard and proceed with calibration.
- **Warning:** Do not allow the calibration cup to touch any of the sensors during this procedure. Damage can occur if the cup makes hard contact with a sensor face.

Temperature-Sensor Check

Temperature is essential to the successful calibration of the other instrument parameters (DO, pH, and specific conductance) so it is important to determine the continued accuracy of the temperature probe. Multiprobe temperature sensors are typically very stable and accurate over a long period of time. Temperature sensors are factory calibrated and cannot be adjusted by the user. Calibration and maintenance (other than general cleaning) of the sensor are not required. However, a check must be performed to ensure the proper calibration of other multiprobe water quality sensors. Temperature data are used by **every** sensor in the sonde. A malfunctioning temperature probe will cause calibration errors.

Check the temperature-sensor accuracy during routine instrument maintenance.

- Using water acclimated to room temperature, put a laboratory thermistor or thermometer with an accuracy of $\pm 0.2^{\circ}\text{C}$ and the instrument into the same water bath. This can be an ice chest or a large bucket.

- Allow the temperature to stabilize and record the reading from the multiprobe instrument and the laboratory thermistor or thermometer in the calibration log. The difference between the two temperatures must be within $\pm 0.2^{\circ}\text{C}$.
- If the temperature of the multiprobe is off by more than $\pm 0.2^{\circ}\text{C}$, schedule the instrument for recalibration by the manufacturer. If the temperature is off by $\pm 0.5^{\circ}\text{C}$ or more, data collected between the accuracy checks may need to be flagged.

The laboratory thermistor or thermometer must be calibrated annually against a National Institute of Standards and Technology (NIST) traceable thermometer. Some electronic thermistors can be calibrated and are to be adjusted to the NIST value. Traditional thermometers cannot be changed; check the NIST thermometer against the lab thermometer and determine a correction value. For example, if the lab thermometer reads 23.1°C and the NIST thermometer reads 23.3°C , a correction factor must be applied to the laboratory thermometer. Each time you take a reading, add 0.2°C . Attach a correction-factor label to the thermometer. The calibration can be performed for TCEQ personnel either during the annual audit or at the annual SWQM meeting. Other monitoring organizations may choose an appropriate time for their annual calibration.

Calibration Standards and Multiprobe-Sensor Solutions

Store calibration standards and electrolyte solutions in a temperature-controlled environment. Date containers upon receipt and again after opening them. Label any secondary containers with their contents and expiration date. Commercially purchased calibration standards, which must be NIST traceable, come with an expiration date. Do not use calibration standards for specific conductance and pH beyond their expiration dates. However, expired calibration standards can be used for rinsing probes during and after calibration. DO-electrolyte and pH reference solutions have an indefinite shelf life.

Specific-Conductance Calibration Standards

Calibrate the conductivity system with a potassium chloride solution of known specific conductance. Choose a standard solution with a specific conductance similar to, but higher than, that of the water being sampled. For example, if the same instrument is used to sample water bodies with specific-conductance values ranging from 250 to $800\ \mu\text{S}/\text{cm}$, calibrate with a standard greater than $800\ \mu\text{S}/\text{cm}$, typically $1,500\ \mu\text{S}/\text{cm}$.

Calibrating Hydrolab Instruments

Specific Conductance

Series 3 (DataSonde 3, H20, Recorder, Reporter) and Quanta Sondes

Series 3 and Quanta Sondes require a one-point conductivity calibration (no zero needed).

- Before calibration, rinse the sensors twice with DI water.
- Use the rubber cap to cover the calibration cup and shake vigorously.
- Rinse at least twice with the chosen standard solution and dispose of the solution.
- Fill the calibration cup, covering the DO sensor, with the calibration standard and allow the sensor to stabilize.

- In Series 3 Sondes, check for air bubbles that may have become trapped in the conductivity cell block. Remove bubbles if present.
- Record the *initial specific conductance value*, *value of standard*, and *temperature of the calibration standard* in the calibration log.
- Using the four Function Keys under the LCD Screen, select *Setup/Cal*, *Calibrate*, and then *Sonde*.
- Use the arrow keys to scroll through the MiniSonde menu options.
- Scroll to *SpCond:μS/cm* (or *SpCond:mS/cm*). Press *Select*.
- Use the arrow keys to move the cursor left or right to enter the conductivity standard concentration. Press *Select* to select the appropriate number. Enter the appropriate concentration, and press *Done*.
- The messages *Calibration Successful*, *Press any key* should appear. Select any function key to remove the message.
- Select *Go Back* and confirm the specific conductance reading from the display screen.
- Record the value *calibrated to* in the calibration log.

Series 4, Series 4a, and Series 5 Sondes (DataSonde and MiniSonde)

Series 4, 4a, and 5 sondes require a two-point conductivity calibration.

- Before calibration, rinse the sensors twice with DI water.
- Replace the storage cup cap to cover the storage cup and shake vigorously.
- Calibrate the zero point first by leaving the conductivity sensor in air.
- Record the *initial value*, the value *calibrated to*, and the temperature in the calibration log.
- Correct the initial specific-conductance value to zero and save the calibration.
- Record the initial value and the value *calibrated to* (zero) in the calibration log, and the temperature in the calibration log.
- Calibrate the second point (“slope”) by rinsing at least twice with the chosen standard solution.
- Fill the storage cup with calibration standard, covering the DO sensor, and allow the sensor to stabilize.
- Record the *initial specific-conductance value*, *the value of the standard*, and the temperature of the standard in the calibration log.
- Correct the initial specific conductance value to match the standard value and save the calibration.
- Record the initial value, the value of the standard, the value calibrated to, and the temperature in the calibration log.

pH Sensor

Calibrate the pH system with a buffer of pH 7.0, and either pH 4.0 for naturally acidic waters or pH 10.0 for alkaline waters. The pH buffers contain high concentrations of phosphate.

During calibration, avoid leaving traces of buffer on equipment or at the workplace that could contaminate water samples.

- Before calibration, check the condition of the probes—ensure that they are intact and free of surface films. If probes appear questionable, perform sensor maintenance according to accepted procedures.
- For Series 3 and Quanta Sondes, remove the storage cup from the sonde and replace with the calibration cup. For Series 4, 4a, and 5 Sondes, remove the cap from the storage cup. Rinse the sensors twice with DI water. Cover the cup and shake it.
- Rinse at least twice with the pH 7 buffer solution.
- Fill the cup, covering the DO sensor, with the pH 7 buffer solution and allow the sensor to stabilize for two minutes.
- Record the *initial pH value* and the *temperature of the calibration standard* in the calibration log.
- Using the temperature of the pH 7 buffer solution, determine the pH 7 calibration value. See Table 8.3 for pH-calibration values corrected for temperature.
- Record the *calibration standard value* in the calibration log.
- Using the four function keys under the LCD Screen, select *Setup/Cal*, *Calibrate*, and then *Sonde*.
- Use the arrow keys to scroll through the MiniSonde menu options.
- Scroll to *pH*. Press *Select*.
- Use the arrow keys to move the cursor left or right to enter the pH standard concentration. Press *Select* to choose the appropriate number, then press *Done*.
- The messages *Calibration Successful*, *Press any key* should appear. Press any function key to remove the message.
- Record the value *calibrated to* in the calibration log.
- Select *Go Back* and confirm the pH reading from the display screen.
- Repeat this procedure with either pH 4 or pH 10 buffer solution. Choose a pH buffer that best represents the pH of the environment to be monitored.

Dissolved-Oxygen Sensor

DO concentrations in water are measured using either a polarographic electrode or optical sensors.

DO-sensor calibration requires a current uncorrected reading for barometric pressure (BP). See below, “Barometric Pressure.”

Clark Polarographic DO Cell Precalibration

Clean the sonde and the stirrer using running water to remove debris. Check the condition of the DO membrane—ensure it is intact and free of wrinkles, bubbles, and surface films. Inspect the appearance of the DO sensor and the electrolyte. Note any discoloration. If probes appear

questionable, perform sensor maintenance according to accepted procedures. Confirm that the circulator or stirrer is operational.

Calibration

- Remove the DO sensor guard if present. Invert the sonde (point its sensors upward) with the calibration cup in place.
- Carefully blot the DO membrane dry using a Kimwipe or a soft towel. Be careful not to apply pressure to the membrane, which can change its tension.
- Fill the calibration cup with water to a level just below the trimmed edge of the DO membrane and O-ring.
- Cover the calibration cup loosely with the cap to prevent air exchange and allow the sensor to stabilize for about five minutes.
- Record the *initial DO% saturation value, temperature, and calibration standard (100%)* in the calibration log.
- Calibrate the DO sensor using *DO% Saturation*. Enter the uncorrected BP stated in mm Hg. See below, “Barometric Pressure.” Using the four function keys under the LCD Screen, select *Setup/Cal, Calibrate*, and then *Sonde*.
- Use the arrow keys to scroll through the Minisonde menu options.
- Scroll to *DO%: Sat*. Press *Select*.
- Use the arrow keys to move the cursor left or right to enter the absolute BP. Select the appropriate number, then press *Done*.
- The messages *Calibration Successful, Press any key* should appear. Select any function key to remove the message.
- Select *Go Back* and confirm the DO percent saturation reading from the display screen. The value should be at or near 100 percent.
- Record the value *calibrated to* in the calibration log. For Hydrolab instruments the value is 100 percent, indicating oxygen saturation referenced to the uncorrected BP input by the user.

Luminescent DO Cell—Series 5 Sondes Only

Precalibration

Clean the sonde using running water to remove debris. Inspect the cap of the luminescent dissolved-oxygen (LDO) sensor cap. If the cap or the sensor appears questionable, perform sensor maintenance according to accepted procedures.

Water-Saturated-Air Calibration

Note: It is important to maintain temperature stability during calibration. Keep the sonde out of direct sunlight and away from any other source of heat or other energy that may change the temperature in the cup during calibration. If the temperature in the cup changes more than 0.5°C during calibration, recalibration is recommended.

To calibrate the sensor using water-saturated air:

- Remove the calibration cup from the sonde. Fill the calibration cup with approximately ½ inch of DI water or tap water (specific conductance < 0.5 mS/cm). See Figure 8.1.

- Before attaching the calibration cup to the sonde carefully remove any water droplets from the sensor cap.
- Gently set the sonde with the sensors down into the calibration cup. Do not fully attach the calibration cup. The goal is to block air exchange with the outside environment. Fully attaching the cup increases the inside pressure and will give a false reading. The water should not touch the sensor cap (see Figure 8.1).
- Allow the DO and temperature readings to stabilize for approximately 5–10 minutes. At this point the air inside the calibration cup should be fully saturated with water.
- Record the *initial DO% saturation value, temperature, and calibration standard (100%)* in the calibration log.
- Calibrate the DO sensor using *LDO% Saturation*. Enter the uncorrected BP stated in mm Hg. See below, “Barometric Pressure.” Using the four function keys under the LCD Screen, select *Setup/Cal, Calibrate, and then Sonde*.
- Use the arrow keys to scroll through the Minisonde menu options.
- Scroll to *LDO%: Sat*. Press *Select*.
- Use the arrow keys to move the cursor left or right to enter the absolute BP. *Select* the appropriate number, then press *Done*.
- The messages *Calibration Successful, Press any key* should appear. Select any function key to remove the message.
- Select *Go Back* and confirm the reading for DO percent saturation from the display screen. The value should be at or near 100 percent.
- Record the value *calibrated to* in the calibration log. For Hydrolab instruments the value is 100 percent, indicating oxygen saturation referenced to the uncorrected BP input by the user.

Calibrating YSI Instruments

Specific Conductance

This procedure calibrates conductivity, specific conductance, salinity, and total dissolved solids.

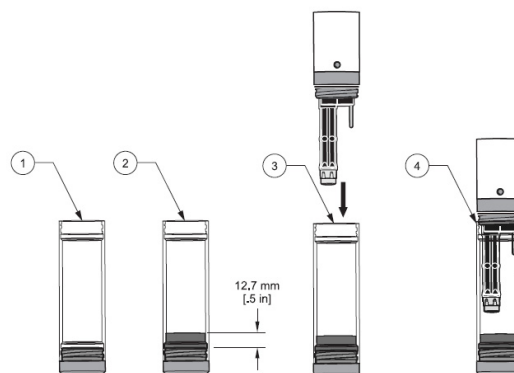

Figure 8.1. Water-Saturated-Air Calibration: (1) Calibration Cup, (2) Filling Calibration Cup, (3) Putting Sonde in Cup, (4) Screwing Calibration Cup to Sonde

Pour enough standard into the calibration cup to fully immerse the cell and temperature sensor. Choose a standard within the same conductivity range as the ambient water to be measured.

Note: Standards with conductivities less than 1 mS/cm (1000 μ S/cm) are not recommended.

- Rinse the sensor twice with the conductivity standard. Fill the calibration cup with the standard. Make sure that the probe is completely immersed past the vent hole. Gently tap the side of the calibration cup to dislodge any air bubbles from the cell.
- Allow at least one minute for temperature equilibration to occur before processing.
- From the Calibrate Menu, select *I—Conductivity* to access the calibration procedure or *I—SpCond* to initiate the procedure for calibrating specific conductance. Enter the calibration value of the standard ms/cm at 25°C and press *Enter*. The current values of all enabled sensors will appear on the screen and will change with time as they stabilize.
- Record the *initial specific conductance value*, *value of standard*, and temperature of the standard in the calibration log.
- Observe readings under *Specific Conductance*; when no significant change is observed for approximately 30 seconds, press *Enter*. The screen will indicate that the calibration has been accepted; press *Enter* again and return to the *Calibrate* menu.
- Record calibration information in the calibration log. Rinse the sonde with DI water.

Conductivity Cell Constant

Record the conductivity probe *cell constant* after calibration. Access the cell constant from the sonde's *Advanced* menu, select *Calibration Constants*. The acceptable range is 5.0 ± 0.5 . The probe cell constant is similar in principle to an instrument offset, and is an indication of how well an instrument has been calibrated. Accepting a bad calibration will cause the cell constant to fall outside of the acceptable range.

The cell constant is a maintenance tool, not a QA or QC measurement. An out-of-range cell constant does not signify an inaccurate measurement and does not mean that data need to be flagged as suspect. Maintenance and recalibration of the sensor are recommended if the cell constant is out of range. Replacement of the sensor may become necessary if the cell constant remains out of range and the sensor fails to calibrate properly.

pH Two-Point Calibration

pH 7

- Rinse the sensors at least twice with pH buffer.
- Place enough pH 7 buffer into the prerinsed calibration cup to immerse the pH probe, reference junction, and thermistor. Allow at least one minute for the temperature to equilibrate before reading.
- From the *Calibrate Menu*, select *4-ISE 1 pH* to access the pH calibration choices, then press *2-2 Point* (or *3-3 Point*). Press *Enter* and input the value of the buffer at the prompt. Press *Enter*, and the current values of all enabled sensors will appear on the screen. Observe the pH mV reading. This value should be $0.0 \text{ mV} \pm 50 \text{ mV}$. Record this value in the calibration log.
- Record the *initial pH value*, and *temperature of the calibration standard* in the calibration log.

- Observe the pH reading and when it shows no significant change for approximately 30 seconds, press *Enter*. The display will indicate that the calibration is accepted.
- Record the value *calibrated to* in the calibration log.
- After the pH 7 calibration is complete, press *Enter* again to continue. Rinse the sonde with DI water.

pH 4 or 10

- Rinse the sensors at least twice with pH buffer.
- Place enough pH 4 (or 10) buffer into a prerinsed calibration cup to immerse the pH probe, reference junction, and thermistor. Allow at least one minute for the temperature to equilibrate before reading.
- Press *Enter* and input the value of the second buffer at the prompt. Press *Enter* and the current values of all enabled sensors will appear on the screen.
- Observe the pH mV reading. This value should range from 130 to 230 in pH 4 buffer, and from -130 to -230 mV in pH 10 buffer. Record this value in the calibration log. See “pH Millivolt Response,” below, for additional information on this response indicator.
- Record the *initial pH value* and the *temperature of the calibration standard* in the calibration log.
- Observe the pH reading. When it shows no significant change for approximately 30 seconds, press *Enter*. After the second calibration is completed, press *Enter* again. If you are performing a two-point calibration, the screen will return to the *Calibrate Menu*.
- Record calibration information in the calibration log. Rinse the sonde with DI water.
- Discard the pH buffer and rinse with DI water (to remove any residual buffer) before calibrating the DO sensor.

pH Millivolt Response

YSI multiprobe instruments report millivolts (mV) as an indicator of pH sensor response. *Millivolt response* should be recorded in the logbook to assist the user with in troubleshooting activities, and to track sensor performance over time. An out-of-range response alerts the user that a probe may soon require reconditioning or replacement. There are expected *mV response* ranges for the various pH buffers:

Buffer	Response
4	130 to 230
7	-50 to +50
10	-130 to -230
Slope	160 to 185

The *mV response* is a maintenance tool, not a QA or QC measurement. An out-of-range mV response does not signify an inaccurate measurement and does not mean that data need to be flagged as suspect. However, a sensor slope (mV difference between pH 7 and 10 or pH 4 and 7) less than 160 mV is an indication that the sensor is malfunctioning and pH data are suspect.

DO (Rapid Pulse Sensor) Calibration for Instantaneous Sampling

- When using the YSI Model 600XLM or Model 6920 for instantaneous (discrete) sampling, disable the auto-sleep function. From the *Main Menu*, select 8—*Advanced* and then 2—*Setup*. If the auto-sleep functions are enabled, select 5—*Auto Sleep RS232* and 6—*Auto Sleep SDI12* and press *Enter* to disable them.
- Pour about $\frac{1}{8}$ inch of water in the bottom of the calibration cup. Place the probe in the cup. Make certain that the DO and temperature probes are not immersed in the water. Engage only one thread of the calibration cup to ensure that the DO probe is vented to the atmosphere. Wait at least 10 to 15 minutes for the air in the calibration cup to become water saturated and for the temperature to equilibrate. **Note:** Run the sonde in *Discrete Mode* while waiting. This will help burn in the sensor and improve stability.
- Record the *initial DO% saturation value* and *temperature* in the calibration log.
- From the *Calibrate Menu*, select 2—*Dissolved Oxygen*, then 1—*DO%* to access the calibration procedure for DO percent saturation.
- Enter the current BP in mm Hg. See below, “Barometric Pressure.”
- Observe the temperature and DO readings; when there is no significant change for approximately 30 seconds, press *Enter*. The screen will indicate that the calibration has been accepted. Press *Enter* again to return to the *Calibrate Menu*.
- Record calibration information in the calibration log. For YSI instruments the value *calibrated to* is determined for each calibration site and oxygen saturation referenced to 760 mm Hg. To determine the calibration standard for DO percent saturation, use the following equation:

$$\text{Current barometric pressure} / 760 \times 100 = \text{DO\% saturation calibration standard}$$

DO (Rapid Pulse Sensor) Indicators

There are several indicators of DO sensor response, *DO gain* and *DO charge*. These indicators are recorded in the calibration log. *DO gain* and *DO charge* ranges should not be considered quality control criteria, but rather guidelines to assist the user in performing maintenance and calibration activities.

- Record the *DO gain*, located in the *Advanced Menu > Cal Constants*. The range should be -0.7 to 1.4 . *DO gain* is similar in principle to an instrument offset, and is an indication of how well an instrument has been calibrated. If you accept a bad calibration, the gain will fall outside of range. If DO gain remains out of range, and the sensor ceases to calibrate properly, its replacement may become necessary.
- Record the *DO charge*, which can be set to appear on the display screen from the *Report Menu*. The range should be 25 to 75. The DO charge is an indicator of membrane, electrolyte, and sensor-electrode condition. When the DO charge falls outside of the acceptable range, perform maintenance procedures—including electrode polishing, and replacement of the KCl solution and the Teflon membrane.

DO (Rapid Pulse Sensor) Calibration for Unattended Sampling

When using the Model 600XLM or Model 6920 in unattended mode, make sure the auto-sleep functions are enabled. From the *Main Menu*, select *8—Advanced* and then *2—Setup*. Ensure that *5—Auto Sleep RS232* and *6—Auto Sleep SDI12* are enabled. If not, select *5—Auto Sleep RS232* and *6—Auto Sleep SDI12* and press *Enter* to enable both functions.

Verify that the sonde DO warm-up time—located in the *Advanced Menu > Sensor*—is set correctly. The 600XLM factory default is 40 seconds; for all other instruments, 60 seconds is recommended. When setting up any YSI instrument, ensure that the warm-up time is set at **90 seconds**, rather than the default.

Calibrate as described in the previous section, “YSI Instruments DO (Rapid Pulse Sensor) Calibration Procedure for Instantaneous Sampling.”

Place the sonde in the calibration cup (vented) with water and allow 15 minutes for the water to saturate. Select *DO%* and activate the countdown timer for the DO warm-up time. After DO warm-up is complete, the readings just before and after calibration are displayed. Press *Enter* when prompted and the screen will return to the *DO Calibration Menu*.

Record the DO gain found at the *Advanced Menu > Cal Constants*. The range should fall between -0.7 to 1.4 .

Record the DO charge, enabled from the *Report Menu*. The range should be 25 to 75.

DO ROX Optical-Sensor Calibration Calibration Using Percent Air Saturation—One Point

The calibration procedure for the DO ROX optical sensor is the same for both discrete and unattended sampling. There are several methods for calibrating this sensor. YSI recommends one-point calibration using water-saturated air to obtain sufficient accuracy under normal operating conditions.

Note: Air-saturated-water calibration of the optical dissolved-oxygen (ODO) sensor will provide the maximum accuracy, since it reduces variability associated with changing air temperature. This method uses a saturated water bath which can simply be a 5 gallon pail that has been sparged with room-temperature air (using an aquarium air pump) for at least 1 hour. Since the air-saturated water method is time-consuming, the water-saturated air method is recommended for routine water quality monitoring in the SWQM program.

Water-Saturated-Air Calibration

- Place the YSI optical DO sensor (6150) into a calibration cup—vented (by loosening the threads)—containing about $\frac{1}{8}$ inch of water. Wait approximately 15 minutes before proceeding to allow the temperature and oxygen sensors to equilibrate.
- Select *ODO sat%* and then *1-Point* to access the DO-calibration procedure. Calibration of the optical DO sensor in the *DO%* mode results in the calibration of the *DO mg/L* mode.
- Enter the current uncorrected BP reading in mm Hg ($\text{mm} = \text{in} \times 25.4$). See below, “Barometric Pressure.”

- Press *Enter* and the current values of all enabled sensors will appear on the screen and change with time as they stabilize. Observe the readings under *ODO sat%*. When there is no change for approximately 30 seconds, press *Enter*. The screen will indicate that the calibration has been accepted. Press *Enter* again to return to the *Calibrate* menu.
- Record the initial value, the value calibrated to, and the temperature in the calibration log. Record the ODO Gain also found at the sonde's *Advanced Menu > Calibration Constants*. The value should fall between -0.7 and 1.45 .

Barometric Pressure

Obtaining the correct BP is essential in calibrating the DO sensor. BP affects the partial pressure of oxygen in saturated water. The higher the BP, the more oxygen can be dissolved in water—thus, the percent-saturation calibration value will also be higher.

If the instrument display unit has an internal BP function installed, take the reading directly from the unit. However, the internal BP function should be checked against a known BP at least once a month. Barometric pressure for both YSI and Hydrolab handheld display units can be calibrated. The calibration of BP follows the general calibration procedure used for other parameters.

Details on calibrating the BP are outlined in the operating manuals for the display units (Appendix 3 for Hydrolab and Section 9.2 for YSI).

For display units without a BP function, a detailed discussion on obtaining the uncorrected absolute BP follows.

Absolute Barometric Pressure

Barometer. Absolute BP is defined as what a mercury barometer would read in the room where the calibration is taking place. There are several options for determining BP. The most direct method is to read a handheld or fixed (mounted) barometer. No corrections are required.

Weather reports. The second option is to obtain a BP reading from a local weather office, radio or television station, weather radio, or similar source. Many local television stations have Web sites or links to sites where local weather information, including BP, is continuously updated. The National Weather Service also offers easy-to-access weather information online. See Appendix A.

Uncorrecting barometric readings corrected to sea level. Most barometric readings obtained from local and Internet sources are corrected to sea level to remove the effect of altitude and are reported in inches of mercury. Sometimes corrections are reported as altimeter readings in inches of mercury.

Convert the barometric reading reported in inches Hg to millimeters (mm) Hg by multiplying inches by 25.4. The **corrected** BP value will always be available; however, you may ask for the **uncorrected** BP. Many stations can provide this absolute reading. The *uncorrected* BP reading (after conversion to mm) can be directly entered, provided the weather station is located nearby and at the same general elevation.

If the BP reading supplied is corrected to sea level, obtain the local altitude where the instrument is being calibrated in feet above sea level from a USGS topographic map or other

source and use the following equation (which is also located on each calibration log sheet), to account for altitude.

<p>Barometric Pressure (BP) = Corrected Barometric Pressure (CBP) – 2.5 (A/100)</p> <p>where BP = estimated absolute barometric pressure</p> <p>CBP = local BP corrected to sea level (from a weather bureau or other source); convert reading supplied in inches to mm: inches × 25.4 = mm</p> <p>2.5 = decrease in constant atmospheric pressure decreases (in mm Hg) for each increase in altitude of 30.5 meters (100 feet)</p> <p>A = local altitude in feet above mean sea level</p>
<p>Example: A BP reading of 29.50 in mm Hg, corrected to sea level, at an altitude of 650 feet above sea level is uncorrected by:</p> $29.5 \text{ inches} \times 25.4 = 749 \text{ mm Hg}$ $\text{BP} = 749 \text{ mm} - 2.5 (650/100)$ $\text{BP} = 732.8 \text{ mm Hg}$

The above equation should be posted in the laboratory or at the site where the instruments are routinely calibrated. Once an initial calculation is made, the last term of the equation, $2.5 (A/100)$, will then be constant and can be subtracted from the corrected BP.

If an instrument needs to be calibrated at a remote location where the BP is not available from the usual sources, the BP can be estimated from the following equation:

<p>Barometric Pressure (BP) = 760 – 2.5 (A/100)</p>
<p>Example: If the altitude at the site of calibration is 1,200 feet above sea level, the estimated BP is:</p> $\text{BP} = 760 - 2.5 (1200/100)$ $\text{BP} = 730 \text{ mm Hg}$

Calculating a DO Calibration Value (mg/L)

Hydrolab and YSI multiprobe instruments use DO% saturation to calibrate the DO sensor. Other instruments may be calibrated using a calculated DO calibration value in mg/L. Use the following procedure to calculate a DO calibration value in mg/L.

- Using the *temperature* recorded at the start of calibration, go to the DO saturation table (Table 8.1) to obtain the *DO saturation value*. For example, the temperature is 22.2°C. The DO saturation value for this temperature is 8.68 mg/L.
- Get the local BP value as described in the previous section. Uncorrect the BP if necessary. For this example, the uncorrected BP is 756.8 mm.

Table 8.1. DO Saturation Values in mg/L (Oxygen Content of Air-Saturated Freshwater at 760 mm Hg)

Temp (°C)	Oxygen Solubility at 760 mmHg									
	0.0	0.1	0.2	0.3	0.4	0.5	0.6	0.7	0.8	0.9
1	14.17	14.13	14.09	14.06	14.02	13.98	13.94	13.90	13.87	13.83
2	13.79	13.75	13.72	13.68	13.65	13.61	13.57	13.54	13.50	13.47
3	13.43	13.40	13.36	13.33	13.29	13.26	13.22	13.19	13.15	13.12
4	13.08	13.05	13.01	12.98	12.94	12.91	12.88	12.84	12.81	12.77
5	12.74	12.71	12.68	12.64	12.61	12.58	12.55	12.52	12.48	12.45
6	12.42	12.39	12.36	12.33	12.30	12.27	12.23	12.20	12.17	12.14
7	12.11	12.08	12.05	12.02	11.99	11.96	11.93	11.90	11.87	11.84
8	11.81	11.78	11.75	11.73	11.70	11.67	11.64	11.61	11.59	11.56
9	11.53	11.50	11.48	11.45	11.42	11.40	11.37	11.34	11.31	11.29
10	11.26	11.23	11.21	11.18	11.15	11.13	11.10	11.07	11.04	11.02
11	10.99	10.97	10.94	10.92	10.89	10.87	10.84	10.82	10.79	10.77
12	10.74	10.72	10.69	10.67	10.64	10.62	10.60	10.57	10.55	10.52
13	10.50	10.48	10.45	10.43	10.41	10.39	10.36	10.34	10.32	10.29
14	10.27	10.25	10.23	10.20	10.18	10.16	10.14	10.12	10.09	10.07
15	10.05	10.03	10.01	9.98	9.96	9.94	9.92	9.90	9.87	9.85
16	9.83	9.81	9.79	9.77	9.75	9.73	9.71	9.69	9.67	9.65
17	9.63	9.61	9.59	9.57	9.55	9.53	9.51	9.49	9.47	9.45
18	9.43	9.41	9.39	9.37	9.35	9.34	9.32	9.30	9.28	9.26
19	9.24	9.22	9.20	9.19	9.17	9.15	9.13	9.11	9.10	9.08
20	9.06	9.04	9.02	9.01	8.99	8.97	8.95	8.93	8.92	8.90
21	8.88	8.86	8.85	8.83	8.81	8.80	8.78	8.76	8.74	8.73
22	8.71	8.69	8.68	8.66	8.65	8.63	8.61	8.60	8.58	8.57
23	8.55	8.53	8.52	8.50	8.49	8.47	8.45	8.44	8.42	8.41
24	8.39	8.38	8.36	8.35	8.33	8.32	8.30	8.29	8.27	8.26
25	8.24	8.23	8.21	8.20	8.18	8.17	8.15	8.14	8.12	8.11
26	8.09	8.08	8.06	8.05	8.03	8.02	8.01	7.99	7.98	7.96
27	7.95	7.94	7.92	7.91	7.89	7.88	7.87	7.85	7.84	7.82
28	7.81	7.80	7.78	7.77	7.76	7.75	7.73	7.72	7.71	7.69
29	7.68	7.67	7.65	7.64	7.63	7.62	7.60	7.59	7.58	7.56
30	7.55	7.54	7.52	7.51	7.50	7.49	7.47	7.46	7.45	7.43
31	7.42	7.41	7.40	7.38	7.37	7.36	7.35	7.34	7.32	7.31
32	7.30	7.29	7.28	7.26	7.25	7.24	7.23	7.22	7.20	7.19
33	7.18	7.17	7.16	7.15	7.14	7.13	7.11	7.10	7.09	7.08
34	7.07	7.06	7.05	7.03	7.02	7.01	7.00	6.99	6.97	6.96
35	6.95	6.94	6.93	6.92	6.91	6.90	6.88	6.87	6.86	6.85

- Next, calculate the *correction factor (CF)* for the DO saturation value. This adjusts the table DO saturation value to the local BP. The correction factor is determined using the following calculation:

$$\text{Uncorrected BP mm} / 760 \text{ mm} = \text{CF}$$

(for example, 756.8 mm / 760 mm = 0.996)

- After determining the correction factor, calculate the *calibration value* using the following equation:

$$\text{table saturation value} \times \text{CF} = \text{calibration value}$$

(for example, 8.68 × 0.996 = 8.82 mg/L)

Calibrating the Depth Sensor

- Zero the depth sensor immediately before making the initial measurement with the instrument at the first station of the day.
- For Hydrolab instruments, calibrate by entering zero for the standard at the monitoring site or laboratory (if the BP at the lab is the same as that of the sample site) to cancel the effect of changes in BP.
- For YSI instruments, from the *Calibration* menu, select *Pressure-Abs* to begin depth calibration. Input *0.00*, press *Enter*, and wait for the reading to stabilize. If no significant change occurs after 30 seconds, press *Enter* to confirm the calibration. This zeroes the sensor with regard to the current BP. Press *Enter* again to return to the *Calibration* menu. Record the BP at the time of calibration.

Post-Calibration Check

The post-calibration check is a QC measure to verify the measurement accuracy of the instrument. A post-calibration check must be performed after each use of the instrument and before any instrument maintenance. The sooner this procedure is performed, the more representative the results will be for assessing performance during the preceding field measurements. Calibration and post-calibration should be no more than 24 hours apart when used for routine monitoring.

After making measurements at the last station, fill the sampling cup with ambient water (not deionized or tap water) and return to the lab. In the lab, take the same care used in performing the initial calibration and—

- Rinse with DI water and the appropriate calibration standard.
- Fill the calibration cup with the standard and allow the instrument to stabilize.
- Read the value directly off the instrument display unit.
- Record the value in the same log used for the calibration.

Do not use the calibration menu during the post-calibration check. No adjustments are made during this process.

The purpose of post-calibration is to determine if the instrument has held calibration during the day of sampling. Compare the post-calibration values to the expected values for the standards, so the field measurements for the day can be reported with confidence. The difference between the post-calibration value and expected standard value can be used to indicate both calibration precision and instrument performance.

24-Hour DO Monitoring

Post-calibration-check requirements for other monitoring activities such as 24-hour DO and continuous monitoring vary depending on the deployment time and location of the site. For 24-hour DO monitoring, the post-calibration check should be done as soon as possible when returning from the field. The period of time an instrument is left at a site when collecting 24-hour DO data is generally based on the instrument being used, the conditions at the site, and the operator's experience with the instrument. The longer the time between calibration and the post-calibration check, the greater the risk of losing data due to failure of the QC checks.

Post-Calibration Check: Error Limits

If post-calibration values fall outside the error limits for DO, pH, and specific conductance, then the data collected do not pass QA and should not be reported (Table 8.2). If post-calibration measurements do not consistently fall within the error limits after in-house troubleshooting, return the instrument to the manufacturer for maintenance. For depth and temperature, errors found during the routine checks need to be corrected by the manufacturer.

Table 8.2. Error Limits for the Post-Calibration Check

Parameter	Value
Dissolved oxygen	± 0.5 mg/L, $\pm 6\%$ saturation
pH	± 0.5 standard units
Specific conductance	$\pm 5\%$
Temperature	$\pm 0.2^\circ\text{C}$
Depth	± 0.2 m at 1 m

General Maintenance

Document maintenance in the calibration and maintenance log.

Short-Term Instrument Storage

- Keep the sensors moist.
- Thoroughly rinse the sensors with tap water upon returning from the field.
- Pour a small amount of tap water into the storage cup. It is not required that the sensors be immersed in water. It is recommended that the sensors be stored with at least 10 mL (approximately 2 teaspoons) of water in the sealed storage cup.

- Avoid storing the sondes where they would be subjected to extreme high and low temperatures. Do not allow water to freeze in the storage cup.

Note: Never use alcohol to prevent freezing—it may damage sensors.

Scheduled Maintenance

Hydrolab Multiprobes

Make sure to observe the following schedule for minimal maintenance, regardless of how much use the instruments get. This schedule has been developed from the record of instrument performance and from consultation with the manufacturer.

Routine maintenance. Carry out these important steps in preventive maintenance.

- Post-calibrate the instrument before general cleaning and maintenance.
- Following post-calibration, rinse off the sensors and store them in tap water. Do not use distilled or deionized water for storage.
- Keep the watertight rubber cable connectors well lubricated and dry on the inside. The best procedure is to store the instrument with all connectors separated and open to the air until dry.
- Check rubber cable connectors regularly to ensure that the mated surfaces are covered with a **thin** film of white silicone.
- As necessary, use tissue paper to remove old traces of silicone and dirt and then reapply the silicone.
- Before calibrating, **flush the entire instrument with clean, fresh water. Use soapy water and a soft brush to clean the outside surfaces of the instrument. A mild dishwashing detergent will work very well. Soak the entire instrument in fresh water for at least 30 minutes.**

Note (DO membrane): Exercise particular caution when cleaning the polarographic dissolved-oxygen membrane as its tension may be affected.

Note (pH electrode): Use a cotton swab or a soft brush to clean the glass bulb of the pH electrode.

Conductivity

Every two months or once every 15 field trips

- For instruments with cell blocks, polish the conductivity electrode shafts and tips with emery paper.
- Remove the O-rings on the electrodes before polishing the electrode shafts. Take care not to scratch the glass pH probe.
- Swab the conductivity cell block with a cotton swab soaked in methanol to remove dirt, grease, and other substances. Rinse twice with deionized water.
- Inspect the small O-rings and replace them if stiff, cut, or flattened.
- Reassemble the components, ensuring that the O-rings are wet to create a proper seal.
- Rinse well with deionized water.

- If possible, let the conductivity electrodes stand in tap water overnight before calibrating again.
- For newer-generation products without cell blocks, clean the conductivity sensor with a cotton swab soaked with methanol or detergent.

pH

Every two months or once every 15 field trips

- Wipe the pH probe with a cotton swab soaked in warm, soapy water.

Note: Alcohol is **not** recommended for cleaning the pH probe as it may damage some of the sensors by drying the glass electrode.

For 4000 series, Surveyor 2, and DataSonde 1 Instruments

- Replace the pH electrolyte solution in the pH reference probe sleeve with 3M KCl solution in pH 7 buffer (225g KCl in 1L of pH 7 buffer).

For Series 3, 4, 4a, and 5 Sondes and Quanta Transmitters

- Replace the pH electrolyte solution with pH reference electrolyte (Hydrolab part number 005308HY), 4M KCl saturated with silver chloride. Additionally, potassium chloride pellets (Hydrolab part number 005376HY) may be added. The KCl pellets serve to maintain the pH reference electrolyte at saturation—useful if working long term in waters of very low conductivity.
- Clean the plastic reference probe sleeve and Teflon junction inside and out with a cotton swab soaked in warm, soapy water.

For 4000 Series, Surveyor 2, and DataSonde 1 Instruments

- Wipe the reference pH electrode (glass bulb) with a cotton swab soaked in warm, soapy water.
- Series 3, Series 4, Series 4a, and Series 5 Sondes and Quanta transmitters use a silver anode in the pH reference probe. This anode should not require cleaning or general maintenance.
- Rinse everything with deionized water before refilling and reassembling.
- When replacing the pH reference sleeve, fill the sleeve completely with pH reference electrolyte. Point the sonde downward and push the sleeve up until it contacts and just covers the O-ring. Then point the sonde upward and continue to push the sleeve all the way to the base of the probe. This allows any trapped air to rise to the top, where it is forced out through the porous Teflon junction with excess electrolyte. As a side benefit, it also serves to clean the Teflon junction.
- Inspect the pH reference sleeve for air bubbles by observing the pH reference probe while inverting the sonde. If a large bubble is found, repeat the filling procedure.
- Some Series 4, 4a, and 5 Sondes may be configured with an integrated pH-reference probe. In those cases, the Teflon junction is noticeably smaller and installed using a screwdriver.
- To refill an integrated pH-reference probe with pH-reference electrolyte, point the sonde upward and fill the reference reservoir using a plastic syringe. This ensures that the reservoir is completely filled and no large air bubbles are left. When it is full, install the Teflon

junction with a screwdriver, using care to not over tighten the junction. Observe excess electrolyte being forced out through the porous Teflon junction.

Every 12 months

- Replace the Teflon junction and O-ring.
- Store spare junctions in a 2–5 molar (> 50,000 $\mu\text{S}/\text{cm}$) KCl solution.

pH Troubleshooting

If pH still doesn't calibrate correctly, do the following:

- Evaluate the condition of the Teflon junction on the terminal end of the pH reference sleeve. The sleeve should slide on easily with some force applied. If the sleeve is difficult to apply, then the junction may have become clogged. In contrast, if the sleeve slides on too easily with little resistance, the junction is too porous. In both instances the junction must be replaced.
- If replacing the junction does not solve pH problems, then clean the probe by alternately soaking it in 0.1 N HCl and then in 0.1 N NaOH for five minutes in each solution. Use the small black caps that protect display unit terminals to isolate the probes for soaking with these solutions.

Safety Note: Wear safety glasses and gloves when working with these corrosive chemicals.

- For 4000 series, Surveyor 2, and DataSonde 1 instruments, clean the glass pH and reference probes at the same time. **Do not** use these solutions on the metallic posts of newer-generation products (H20, Reporters, Recorders, DataSondes 3 or 4, and MiniSondes).
- Reattach the calibration cup, fill it with pH 4.0 buffer, and allow all probes to soak an additional 10 minutes.
- Thoroughly rinse with deionized water and refill the pH reference sleeve.
- If those two procedures do not correct pH problems, check with the manufacturer. A new probe may be required.

Batteries

Every two months or once every 15 field trips

- Review the calibration and replacement schedule for batteries.
- Recharge the 6-volt NiCad Gel cell batteries (nickel-cadmium or nickel-metal hydride) for 12 to 24 hours, regardless of the voltage displayed by the instrument. Ensure that NiCad batteries are recycled or disposed of properly. They should not be put in the regular trash.

Stirrer

Every two months or once every 15 field trips

For 4000 Series, Surveyor 2, and Series 3 Stirrers

Lift the impeller off its post. Thoroughly clean all lubricant, dirt, and debris from the impeller and the post. Reapply a very small amount of silicon grease to the tip and replace the impeller on its

post. Test the stirrer's performance; if sluggish, wipe away excess silicon grease from the impeller post and retest.

For Series 4, 4a, and 5 Sondes and Quanta Transmitters

Remove the screw that holds the impeller in place. Visually inspect the impeller—it should move very freely on the screw. If there is any resistance, clean the bore in the impeller using the screw. Replace the impeller if it should show extreme wear.

Test the screw for straightness by laying it on a desktop and gently pushing it. A straight screw should roll in a circle without any noticeable wobble. Replace it if crooked.

Visually inspect the impeller bearing for extreme wear. Replace it if it is worn out.

Reinstall the impeller bushing, the impeller, and the impeller screw. Make certain that the impeller is oriented with the dimples upward. Test the stirrer performance.

Dissolved Oxygen

Every six months or once every 15 field trips

Clark Polarographic DO Cell

- Change the DO membrane and add fresh DO electrolyte (Hydrolab part number 000537HY).
- Invert the sonde on a ring stand.
- Remove the DO guard, the O-ring, and the old membrane.
- Shake out the old DO electrolyte.
- Rinse the DO cell twice with fresh DO electrolyte.
- Fill the DO cell with fresh DO electrolyte. Gently tap the side of the DO cell to release any bubbles trapped in the DO cell.
- Replace the DO membrane (Hydrolab part number 002589HY) and secure with the O-ring (Hydrolab part number 000498HY). See Figure 8.2.
- Visually inspect the membrane for wrinkles, tears, or trapped air bubbles.
- Remove the membrane and pour out the DO electrolyte.
- Rinse the DO cell with deionized water.
- Invert the sonde on a ring stand and, with a small syringe, fill the DO cell with 1:1 ammonia solution until the anode is covered. Do not allow the ammonia solution to contact the gold cathode ring. Have a moist towel available to wipe the ring if needed.
- Let stand for 10 minutes.
- Rinse twice with deionized water and refill according to the standard procedure as described above.

- A. Secure a membrane between your thumb and the probe body. Add electrolyte solution to the probe until a large meniscus covers the gold-colored cathode.

Note: Handle membrane material with care, touching only the edges.

- B. With the thumb and forefinger of your other hand, grasp the free end of the membrane.
- C. With a continuous motion, stretch the membrane up, over, and down the other side of the sensor. Stretching forms the membrane to the contour of the sensor tip.
- D. Secure the end of the membrane under your forefinger while still holding the probe.
- E. Roll the O-ring over the end of the probe, being careful not to touch the membrane surface. There should be no wrinkles in the membrane or trapped air bubbles under it. Some wrinkles may be removed by lightly tugging on the edges of the membrane beyond the O-ring.
- F. Trim off excess membrane with scissors or a knife.

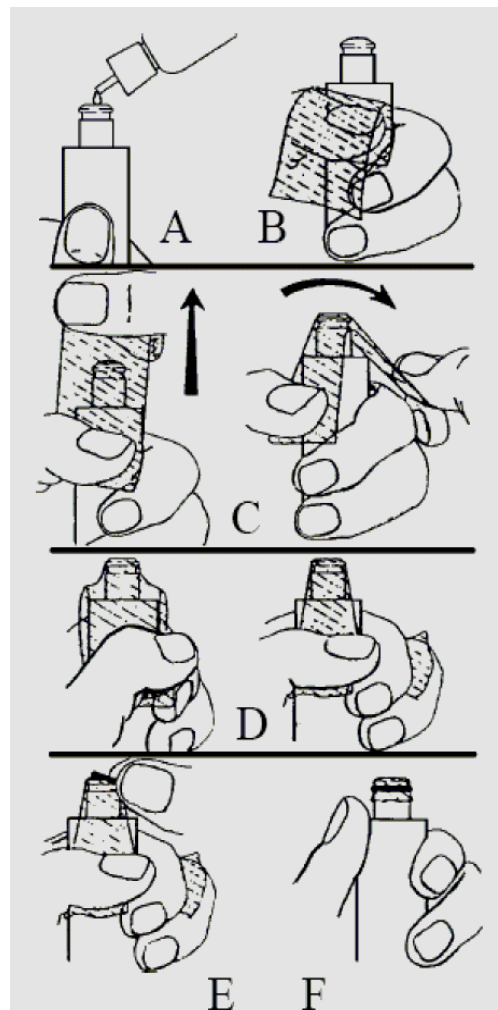

Figure 8.2. Replacing the DO Membrane

(text, Southern Illinois University, 2003; illustration from YSI operations manual)

Troubleshooting Notes

1. If anything other than a rapid and stable oxygen calibration occurs, replace the membrane as a first step in troubleshooting. Please note that the new DO membrane is stretched during installation (see Figure 8.2). This stretching affects the rate of diffusion for oxygen molecules passing through the membrane to the DO cell. As the membrane relaxes, the rate of diffusion will change unpredictably. For that reason it is recommended that the newly installed DO membrane be allowed up to eight hours to ensure total relaxation. If the sonde must be pressed into service, 2–3 hours is recommended to allow the membrane to achieve at minimum approximately 80 percent relaxation.
2. If it is necessary to use the DO probe before the new membrane has eight hours to relax, carefully recalibrate the probe immediately before taking each set of measurements.
3. If the gold cathode ring is discolored or appears tarnished, polish it lightly with a lint-free cloth or a pencil eraser. **Point the sonde downward to prevent any debris from falling into the DO cell. Flush the cell twice with DO electrolyte to remove any debris.**

4. **The white triangular anode in the center of the DO cell may discolor with use, darkening from white to gray to black. The darkening is generally caused by a buildup of silver oxide. Darkening of the anode indicates wear, but does not automatically indicate a problem.** The anode may be cleaned using a 1:1 solution of household ammonia and deionized water.

Luminescent DO Cell—Series 5 Sondes Only

The Hach LDO sensor is not affected by fouling or other debris, unless the growth is an organism that locally consumes or produces oxygen, such as barnacles, or algae growing on the sensor cap. Nevertheless, the manufacturer recommends periodic maintenance to remove contaminants such as oil, biological growth, and dirt. Sensor maintenance should be conducted after every deployment cycle.

Visually inspect the LDO sensor cap. Use optical tissue or a cotton swab with soapy water to clean the sensor cap. Rinse with fresh water.

Note: Do not use organic solvent solutions such as acetone or methanol with the Hach LDO sensor. Those solvents will damage the plastic sensor cap.

Avoid removing the LDO sensor cap unless the cap is being replaced. If the cap is sealed properly using the top O-ring seal, no water should be present between the cap and the clear plastic window and the top of the probe. If water is present, remove the cap and thoroughly dry the inside of the cap and the clear plastic window. The cap may require replacement.

For detailed instructions on replacing the LDO sensor cap, refer to the *Hach LDO Sensor Instruction Sheet* (see Appendix A).

Sonde

Every 12 months

Replace desiccant inside the display and sonde units.

YSI Multiprobes

The following schedule for minimum maintenance is mandatory, regardless of the use that the instruments get. This schedule has been developed from the record of instrument performance and in consultation with the manufacturer.

DO Probe

- Change the KCl solution and membrane before each long-term deployment and at least once every 30 days.
- Replace the KCl and membrane if (a) air bubbles are visible under the membrane, (b) deposits of dried KCl appear on the membrane or O-ring, (c) the readings are unstable, or (d) the DO charge reading is less than 25 or greater than 75.
- If the DO charge is higher than 75, perform maintenance on the DO probe.
- Remove the membrane and dry the probe completely with lens-cleaning tissue.
- Next, hold the probe in a vertical position, place one of the fine sanding disks (in the 6035 DO Probe Reconditioning Kit) under your thumb, and stroke the probe face in a direction

parallel to the gold electrode. The motion should be similar to that used in striking a match. Stroke the electrodes 10 times in each direction.

- After completing the sanding procedure, rinse the probe face with water and wipe with lens-cleaning tissue to remove any grit left by the sanding disk.
- After cleaning, thoroughly rinse the entire tip of the probe with water.
- Replace the KCl solution, install a new membrane, and change the O-ring that retains the membrane. A loose-fitting O-ring can allow the electrolyte to leak out and cause noisy data.

Notes: (1) Use **only** the fine sanding disks provided in the 6035 maintenance kits. (2) Sand parallel to the gold electrode.

Conductivity and Temperature Probe

- The conductivity cell must be cleaned regularly to remove deposits formed on the electrode. The conductivity cell constant should be in the range of 4.5–5.5.
- Dip the cleaning brush into water and insert into each hole 15–20 times. You may also use a mild detergent to remove deposits from the electrodes.
- Rinse the cell with tap water, then rinse it several times with deionized water.
- After cleaning, check the response and accuracy of the conductivity cell with fresh standard.
- Check the cell constant to ensure that it is within the specified range.
- Dry the sonde port and probe connector.
- Clean probe O-rings and apply a very thin coat of lubricant before installation.
- Keep the thermistor clean and free of debris, using water and a cotton swab. Use mild detergent and a cloth, as necessary.

Notes:

- To access the conductivity cell constant using the 610-D display: from the main menu, select *Smart Terminal*, then choose *Advanced*, and choose *Cal constants*.
- To access the cell constant using the 610-DM display-logger: From the *Main Menu*, select *Communications* and then *Smart Terminal*. Select *Advanced* and then choose *Cal constants*.
- To access the conductivity cell constant using PC 6000 or Ecowatch software, select 8—*Advanced*, press *Enter*, and then choose 1—*Cal constants*.

pH Probe

Cleaning is required whenever deposits or contaminants appear on the glass surface of the probe. Use clean water and a cotton swab to remove all foreign material from the glass bulb. Use a moistened cotton swab to carefully remove any material that may be blocking the reference electrode junction of the sensor.

If good pH is not restored, perform the following procedure:

1. Soak the probe for 10 to 15 minutes in clean water containing a few drops of dishwashing liquid.
2. **Gently** clean the glass bulb with a cotton swab.

3. Rinse the probe with clean water, wipe with a cotton swab saturated with clean water, and then rinse with clean water again.

If you suspect biological contamination of the reference junction, or if good response is not restored by the above procedures, perform the following cleaning steps:

1. Soak the probe for approximately one hour in a 1:1 dilution of commercially available chlorine bleach and water.
2. Rinse the probe with clean water and then soak for at least one hour in clean water with occasional stirring to remove residual bleach from the junction. (If possible, soak the probe for a period of time longer than 1 hour in order to remove all traces of chlorine bleach.) Then rinse the probe again with clean water and retest.

Caution: Dry the probe port and probe connector and apply a very thin coat of O-ring lubricant to all O-rings before reinstallation.

Depth Sensor

Clean the depth sensor after each deployment or when readings become unstable. At the side of the instrument there is a circular cap with two or four small holes that protect the depth sensor. The cap cannot be removed, but a syringe is supplied in the maintenance kit for cleaning the pressure port. Fill the syringe with clean water, place the tip of the syringe into one of the holes, and gently force water through the pressure port. Ensure that water comes out of the other hole. Continue flushing the pressure port until the water comes out clean.

Note: Never try to remove the circular pressure-port cap.

Long-Term Storage of Hydrolab Instruments

The following information applies specifically to Hydrolab instruments. Refer to the YSI instrument manual for long-term storage recommendations specific to YSI instruments.

Field instruments are often stored for indefinite periods of time. For example, backup instruments are used during repair of the primary instrument. The instrument cannot be kept in a perpetual state of readiness without regular maintenance.

Whenever multiprobe instruments are to be stored for extended periods of time, make the following preparations:

- Thoroughly clean the probes.
- Remove installed batteries such as AA or C cells. If a lithium battery powers the multiprobe internal clock, **do not** remove it.
- Fill the storage cup with 1 inch of clean tap water and screw the cap onto the instrument.
- Store the instrument in a location where freezing will not occur, away from direct sunlight.

The instrument can be reliably reactivated the day before field use with minimal effort.

Downloading Data

HyperTerminal is readily available software that can be used to download data from both YSI and Hydrolab instruments. YSI also uses EcoWatch for Windows to download data; its use is detailed in the *YSI 6-Series User's Manual*. See Appendix A; also refer to the manufacturer's instruction manual for specific details on programming instruments and downloading data from long-term deployments.

Calibration					
Date:	Time:	Employee Name:			
Battery Voltage:		Sonde Type and Serial No.:			
Function	Temp. of Standard	Value of Standard	Initial Reading	Calibrated to	Comments
Specific conductance (high) $\geq 1,000 \mu\text{S/cm}$					
Conductivity cell constant					Range 5.0 ± 0.5
pH calibrated (~7)					
pH mV for pH 7 solution					Range $0 \pm 50 \text{ mV}$
pH slope (~ 4/10)					
pH mV for pH 10 pH mV for pH 4					Range: -130 to -230 mV Range: 130 to 230 mV
Dissolved oxygen (%sat) *					
Dissolved-oxygen charge					Range 25 to 75
Dissolved-oxygen gain					Range 0.7 to 1.4
DATA NEEDED FOR DISSOLVED-OXYGEN CALIBRATION					
Altitude (A) = _____ feet above MSL Barometric pressure _____ inches _____ mm					
Barometric-Pressure (BP) Options		Barometric-Pressure Formulas			
Barometer		Barometric pressure (inches) _____ $\times 25.4 = \text{BP}$ _____ mm			
From local source after correction (CBP)		BP _____ mm = CBP _____ mm $- 2.5$ (altitude ____/100)			
Estimated from altitude only		BP _____ mm = $760 \text{ mm} - 2.5$ (altitude ____/100)			
* DO% saturation standard calculation Current barometric pressure in mm / 760 \times 100					
Deployment Checklist (required for data logging only)					
Logging interval: Yes No		SDI-12 Autosleep enabled: Yes No			
DO warm-up time:		Battery volts in sonde (days):			
RS 232 autosleep enabled: Yes No		Available memory in sonde (days):			
Post-Calibration Check					
Date:	Time:	Employee Name:			
Battery Voltage:		Sonde Type and Serial No.:			
Function	Temp. of Standard	Value of Standard	Initial Reading	Comments	
Specific conductance					
pH calibrated (~7)					
pH slope (~ 4/10)					
Dissolved oxygen (% sat) *					
Barometric pressure _____ inches _____ mm			Were data associated with this cal/post-cal used? Yes No		
Check previous maintenance and use; do the following before calibration as scheduled:					
Brush conductivity cell. Must be cleaned within the last two months or once every 15 field trips or deployment days.		Date:	Name/comments:		
Inspect DO membrane for nicks or bubbles. Must be changed within last six months or once every 15 field trips or deployment days.		Date:	Name/comments:		
Temperature: Check temperature as part of routine maintenance against NIST traceable thermometer		Date:	Thermometer:	Sonde:	Difference:
Location of Deployment, Routine Run, or Special Study:		Date/Time Deployed:		Date/Time Retrieved:	
Use (circle one):	24-hour	Continuous	Grab	Referee	

Figure 8.3. YSI Multiprobe Calibration and Maintenance Log

Date:	Time:	Employee Name:			
Battery Voltage:		Sonde Type and Serial No.:			
Calibration					
Function	Temp. of Standard	Value of Standard	Initial Reading	Calibrated to	Comments
Specific conductance (zero)					
Specific conductance (2nd point or slope)					
pH calibrated (~7)					
pH slope (~ 4/10)					
Dissolved oxygen*					
*DO% saturation standard calculation Current barometric pressure in mm / 760 × 100					
Altitude (A) = _____ feet above MSL		Barometric pressure _____ inches _____ mm			
Barometric-Pressure (BP) Options		Barometric-Pressure Formulas			
Barometer		Barometric pressure (inches) _____ × 25.4 = BP _____ mm			
From local source correction (CBP)		BP _____ mm = CBP _____ mm – 2.5 (altitude ____/100)			
Estimated from altitude only		BP _____ mm = 760 mm – 2.5 (altitude ____/100)			
Post-Calibration					
Date:	Time:	Employee Name:			
Battery Voltage:		Sonde Type and Serial No.:			
Function	Temp. of Standard	Value of Standard	Initial Reading	Was this within post-calibration error limits? Yes No	Were data associated with this Cal/Post-Cal used? Yes No
Specific conductance					
pH calibrated (~7)					
pH slope (~ 4/10)					
Dissolved oxygen*					
* DO% saturation standard calculation Current barometric pressure in mm / 760 × 100					
Altitude (A) = _____ feet above MSL		Barometric pressure _____ inches _____ mm			
MAINTENANCE (Refer to Chapter 8 for maintenance requirements)					
Temperature Check	Sonde	Thermometer	Difference	The difference between the thermometer and sonde should be within ±0.2°C	
Temperature				Perform temperature check along with regular maintenance	
Sensor	Date	Initials	Maintenance Completed		
pH					
DO					
Specific Conductance					
Location of Deployment, Routine Run, or Special Study:			Date/Time Deployed:	Date/Time Retrieved:	
Use (circle one):	24-hour	Continuous	Grab	Referee	

Figure 8.4. Hydrolab Multiprobe Calibration and Maintenance Log

Table 8.3. pH-Calibration Standards

Temperature (°C)	pH 4 Standard	pH 7 Standard	pH 9 Standard	pH 10 Standard
10	4.00	7.06	9.33	10.15
11	4.00	7.06	9.32	10.14
12	4.00	7.05	9.31	10.13
13	4.00	7.05	9.30	10.12
14	4.00	7.04	9.29	10.11
15	4.00	7.04	9.28	10.10
16	4.00	7.04	9.27	10.09
17	4.00	7.03	9.26	10.08
18	4.00	7.03	9.25	10.07
19	4.00	7.02	9.24	10.06
20	4.00	7.02	9.23	10.05
21	4.00	7.01	9.22	10.05
22	4.00	7.01	9.21	10.04
23	4.00	7.00	9.20	10.03
24	4.00	7.00	9.19	10.01
25	4.00	7.00	9.18	10.00
26	4.00	7.00	9.17	9.99
27	4.00	7.00	9.16	9.98
28	4.01	6.99	9.16	9.98
29	4.01	6.99	9.15	9.97
30	4.01	6.99	9.14	9.96
31	4.01	6.99	9.13	9.95
32	4.01	6.99	9.13	9.94
33	4.02	6.98	9.12	9.93
34	4.02	6.98	9.12	9.92
35	4.02	6.98	9.11	9.91
36	4.02	6.98	9.10	9.90
37	4.02	6.98	9.09	9.89
38	4.02	6.98	9.08	9.88