



Partner in Growing



User Manual

Original document

version 2015-1



Easytopper

Machine nr.:



Javo BV
PO Box 21
2210 AA Noordwijkerhout
Holland
T: +31 (0)252 343121
F: +31 (0)252 377423
info@javo.eu
www.javo.eu

© All rights reserved

The information provided herein may not be reproduced and/or published in any form, by print, photo print, microfilm or any other means whatsoever (electronically or mechanically) without the prior written authorisation of JAVO BV.

Preface

This user manual is written for anyone working on or with the machine. Before working on or with the machine, first read this manual.

This user manual contains important instructions / information on how to use the machine in a safe, professional and economical way and must always be available where the machine is used.

In addition to this user manual, the mandatory rules and regulations for accident prevention and environmental protection in the country and place of use of the machine must also be observed.

This user manual contains information on the operation of the machine with all the possible options. Use only the information that applies to your machine. Depending on the intensity of use and customer requirements, this machine can be equipped with various options. Contact your sales consultant.

Supplier details if not directly supplied by Javo BV. Dealer stamp:



Javo BV is not responsible for any errors in this manual or the consequences thereof.

Javo BV is not liable for damage or consequential damage caused by operating errors, lack of expert maintenance and any use other than described in this manual.

The liability of Javo BV also expires once modifications or additions are made without written permission of Javo BV.

This machine is suitable for process and environmental conditions as stated in section "Specifications and Tolerances" of this manual. Any other use is not authorized by Javo BV and this allows the operator and / or its environment at risk.

Table of contents

1	Technical specifications and tolerances	4
1.1	Type plate.....	4
2	Safety.....	5
2.1	Provisions	5
2.2	Safety devices on the machine	6
2.3	Explanation of icons and symbols.....	6
3	Description of the machine	7
3.1	Machine overview.....	7
3.2	Outline drawing with main dimensions	7
3.3	Options.....	8
3.4	Operation	8
3.5	Machine workstations.....	8
3.6	Controls.....	9
4	Transport	10
5	Mounting, installation and commissioning	11
5.1	Placement	11
5.2	Facilities to take care of by the user	11
5.3	Mounting / Connecting.....	11
5.4	Check elevator rotation direction.....	12
5.5	Check elevator chain tension.....	12
5.6	Check substrate conveyor tension.....	12
5.7	Set substrate conveyor speed.....	13
5.8	Set speed, rotation direction and rotation speed of the string conveyors.....	13
5.9	Set the wipers position	13
5.10	Set the width of the string conveyors.....	14
5.11	Fill substrate bin.....	14
6	Operation.....	15
6.1	Start.....	15
6.2	Stop	15
6.3	Emergency stop.....	15
7	Maintenance	16
7.1	Required tools and equipment	16
7.2	Preventive Maintenance.....	16
7.3	Elevator cleaning.....	17
7.4	Test safety circuit	17
7.5	Fault list.....	17
7.6	Drawings and schemes.....	18
7.7	Spare parts	18

7.8	JavoNet.....	18
7.9	Customer support and advice.....	19
8	Disposal of machine or machine parts	19
9	EG-conformity statement.....	20

1 Technical specifications and tolerances

This machine is intended to be used for filling pots automatically with substrate only. The filled pots are discharged over a conveyor belt. This machine is meant for processing pots, substrate and other materials that are described in this manual only. Detailed operation of the machine is described in section "Operation".



This machine may be used only within the limits for specifications and tolerances of the order, on the assembly drawing and indicated in this manual. If the machine is used outside these specifications, Javo BV cannot take responsibility for this machine.



This machine is intended for products as agreed in the order confirmation only. To ensure the proper operation of this machine, only products with specifications and tolerances as specified in the order may be used.



Do not use the machine for purposes other than the intended purpose of Javo BV. This can lead to damage and danger to the operator and its environment.



This machine is CE marked. When placing multiple machines in one line, the entire line must be properly CE marked before using this machine. Until proper CE Marking of the line is carried out, commissioning of this machine is prohibited.

Specifications	
Voltage	400Volt 50Hz 3~+N+ PE
Machine connection	16A 5pole CEE plug
Power consumption	1,2 kW
Weight	±750 kg
Height conveyor	830 mm
Length x width x height	3160 x 1730 x 2210 mm
Max. speed	± 6.000 pots/h (strongly dependent on pot size)
Min. speed	0 pots/h
Minimum pot diameter	8 cm
Maximum pot diameter	32 cm (12 Litre)
Content substrate bin	± 770 Litre
Working direction pots	Both left and right acting (ex works)
Adjustment transit string ties	Elevator side is fixed and the other is easily adjusted with a lever.
Suspension	Adjustable in width.
Substrate Slide in the substrate bin	Standard.
Pot wiper	3 wiper incl. suspension and adjustment
Operation machine	Movable control box incl. Start / stop / reset.
Maximum passage pots	27 cm at 1,5 cm height of pots led strip.
Belt guide	Height adjustable in small increments.
Year of construction	See type plate.
Type product	As agreed in the order confirmation.

1.1 Type plate

The type plate is placed onto the main cabinet door.



Partner in Growing

Westeinde 4 2211 XP Noorwijkerhout Nederland
www.javo.eu info@javo.eu

Type	
Machine nr.	
Bouwjaar	
<input type="checkbox"/> V	<input type="checkbox"/> kW
<input type="checkbox"/> A	<input type="checkbox"/> Hz



2 Safety



This machine is built according the state of the art technique and the accredited safety regulations. Despite this, the body and life from the user or third parties can be in danger when using it. There could also arise damage to the machine or other goods when using it.



This machine is CE marked. When placing multiple machines in one line, the entire line must be properly CE marked before using this machine. Untill proper CE Marking of the line is carried out, commissioning of this machine is prohibited.

2.1 Provisions

1. Operation and maintenance of this machine must be performed by qualified personnel in compliance with warnings on the machine and in accordance with the user manual. Keep children and other (unauthorized) persons away while using machine.
2. This machine is suitable for process and environmental conditions as stated in section "Specifications and Tolerances" of this manual only. Any other use is not authorized by Javo BV and this allows the operator and / or the environment at risk.
3. It is prohibited to modify this machine, without prior written approval of Javo BV.
4. Thermal fuses and torque limiters may not be set different upon delivery of the new machine. The thermal circuit breakers should never be used to turn on / off the machine.
5. This machine should be installed so that there is sufficient space remaining for providing safe instructions and / or performing maintenance and / or inspections. Put the brakes on the castors before the machine is turned on.
6. Keep the work area clean and well lit. Cluttered or dark areas invite accidents.
7. This machine is not suitable to be used outside. Electrical components are only splashproof. Keep the machine away from rain and moisture. When using the machine in a humid environment is unavoidable, you should use an RCD.
8. Keep hands, hair, loose clothing and / or jewelry away from moving parts of the machine. Wear appropriate clothing without loose parts. Wear non-slip work shoes.
9. As long as the machine is on, no connection or safety devices may be removed. The machine may only be used when all protective devices and safety-related facilities are available and ready for use.
10. Do not stand on the machine when it is operating.
11. Never move the machine if the power cable and / or pneumatic supply is still connected.
12. Prescribed checks and maintenance in the user manual must be observed.
13. Allow the machine to be serviced and repaired by qualified personell only with original replacement parts.
14. In addition to the user manual, generally applicable statutory and other regulations regarding accident prevention and environmental protection have to be respected. This is also referred to handling of personal protective equipment.
15. Inform operating personnel before start maintenance. Interrupt if possible the power (mains), before start machine investigation or maintenance by turning off the main switch and locking the main switch. Pull the plug from the wall socket.
 - a. As work must be done with power supply (mains) voltage on the machine, then arrange an additional person who can operate the emergency stop.
16. When a machine part is damaged or not working in the prescribed manner, the work must be interrupted immediately. Resumption allowed only when the machine part is repaired or replaced and checked. Consult your dealer if the machine is not functioning properly.
17. Machine and / or parts must be disposed in accordance with local laws and regulations.

2.2 Safety devices on the machine



Caps and doors are screening moving parts. Always place back caps and close doors before the machine is turned on. Caps and doors should remain closed while operating the machine.

The motors of the machine are protected against overload by thermal switches. These switches are located in the control box.

2.3 Explanation of icons and symbols

Pictogram	Meaning
	Read and understand this manual before using the machine and / or performing maintenance.
	Remove Power (mains).
	Wear during all work on or with the machine safety shoes and safety glasses.
	Wear during cleaning and maintenance work on this machine also safety gloves and protective clothing.
	Warning. Important points and / or instructions regarding safety and / or injury prevention are marked with this warning sign.
	Dangerous electrical voltage. Dangerous electrical voltage present.
	Risk of crushing. Danger of moving or rotating parts.
	It is forbidden to wear Loose clothing, long hair and / or jewelry nearby moving parts of the machine.
	Trespassing.
	Do not rinse control cabinet Danger of moisture in the cabinet when it is rinsed with water.

Symbols that may be present on this machine			
Drill 	Direction of movement 	Speed ground feeder (curved) 	Speed ground feeder (straight)
Speed pot belt (curved) 	Speed pot belt (straight) 	Brush disc Rotofill 	Tray belt Rotofill
Rotor Rotofill 			

3 Description of the machine

3.1 Machine overview

- A. Substrate bin
- B. Belt transport
- C. Elevator
- D. Exit
- E. Wipers
- F. Movable control box
- G. Main cabinet



3.2 Outline drawing with main dimensions

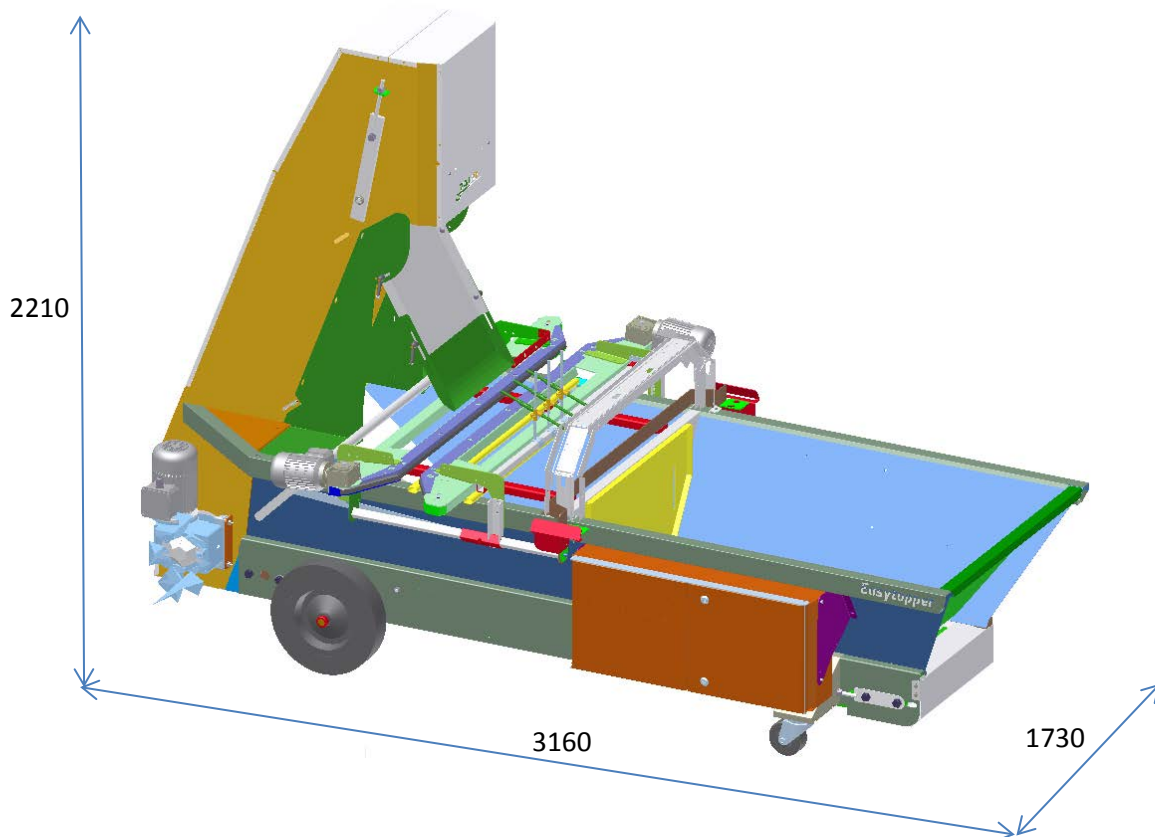

3.3 Options

Depending on the intensity of use and customer requirements, this machine can be equipped with various options. Contact your sales consultant.

Options	Code	Specifications
4 meter 5x1.5 cable incl. 16A plug	900965	
Continuous socket	900966	Non Standard
Substrate bin increase		705 Litre extra
Extra set pot wiper		3 wiper incl. suspension and adjustment

3.4 Operation

This machine is intended to be used for filling pots automatically with substrate only. The filled pots are discharged over a conveyor belt. This machine is meant for processing pots, substrate and other materials that are described in this manual only.

The process of the machine starts with the substrate bin, which is filled with substrate. By using the substrate conveyor belt, the substrate is transferred to the elevator.

The elevator takes over the substrate and transfers it over the discharge opening onto pots.

The pots are moved under the elevator by the string conveyor. Excess substrate is scraped from the pots.

The machine is equipped with wheels, which makes the machine easy to move.

3.5 Machine workstations

This machine has no operator places. Adjustments on this machine has to be carried out when the machine is off.

3.6 Controls

The motor is controlled with the control panel. This control panel is flexible around the machine to be used by means of a cable. The control panel consists of the following buttons;

- A. Start button
- B. Stop button
- C. Reset button

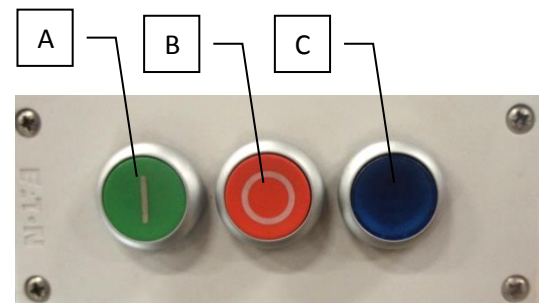

At the electrical cabinet of the machine, these buttons and connectors are placed:

- A. Main switch
- B. Elevator off / on
- C. Pot conveyor off / on
- D. Speed adjustment string conveyor left
- E. Speed adjustment string conveyor right
- F. Error indication

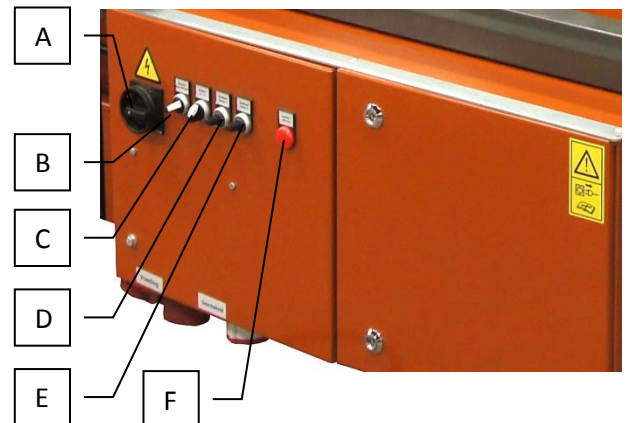

- G. Continuous power IN
- H. Switched power OUT (optional)

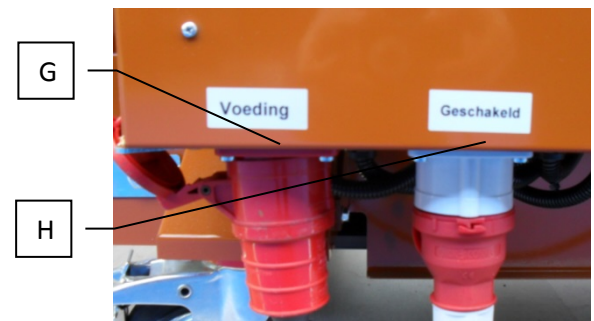

The machine is equipped with 2 emergency stop buttons (at the left and right hand side of the substrate bin).



The string conveyor and elevator can be controlled by frequency converters, which control the speed of motors. The potentiometers are mounted on a control panel:

- Frequency inverter string conveyor
- Frequency inverter elevator (option)

Information about inverters is added to this manual separately.

4 Transport



Follow all instructions described in this manual, in particular chapter safety.

On delivery of the machine, a Javo mechanical engineer must be present to unload the machine from the (freight) wagon.

Prior to moving the machine, the power should be disconnected. Make sure the cables are stowed sufficiently.

When moving within the company (when the machine does not need to be lifted) the state of the machine should be checked. Make sure the path to be travelled is free, so the machine can be moved to the desired position without obstacles.

If the machine is to be lifted for movement (outside the company), please contact your dealer or contact a professional shipping company.

The machine must be transported upright.

The relative humidity should not be too high so that water condenses in the machine.

Report damage during or immediately after delivery to the transport company and to Javo BV. Take all necessary steps to prevent further damage.

5 Mounting, installation and commissioning



Follow all instructions described in this manual, in particular chapter safety.



This machine is CE marked. When placing multiple machines in one line, the entire line must be properly CE marked before using this machine. Up to CE Marking of the line, commissioning of this machine is prohibited.

5.1 Placement

The machine must be placed on a flat surface, with sufficient weight capacity. Install the machine so that there is enough space left for service providing, safe instructions and / or cleaning, maintenance and / or inspections. Put the brakes on the castors before the machine is turned on.



This machine is not suitable to be used in the open air. Electrical components are only splashproof. Keep the machine away from rain and moisture. When using the machine in a humid location is unavoidable, you should use an RCD.

5.2 Facilities to take care of by the user

Prior to delivery of the machine, the required materials and facilities (air, power, substrate, etc.) needs to be present within 3 meters of machine.

Required power supply: 400 Volt, 3 Phase + Neutral + Earth. (N. America: 208/220V 60Hz.).

5.3 Mounting / Connecting

If applicable, the components supplied are to be mounted on the machine. Make sure that the moving parts are free. If the machine is complete, it can be connected (by a competent person) to the power supply.



Keep hands, hair, loose clothing and / or jewellery away from moving parts of the machine. Wear appropriate clothing without loose parts. Wear non-slip work shoes.



As long as the machine is on, no connection or safety devices may be removed. The machine may only be used when all protective devices and safety-related facilities are available and ready for use.

5.4 Check elevator rotation direction



Check the rotation direction of the elevator before you start working with the machine.

Procedure:

1. Connect the power cable.
2. Start the elevator.
 - a. Turn off the main switch.
 - b. Press the reset button emergency stop circuit.
 - c. Start the elevator with the elevator button.
3. Check the direction of rotation of the elevator.
 - a. The correct rotation direction is shown at the picture.
4. Stop the elevator by turning the elevator switch off.
5. Switch the main switch off.
6. When rotation direction is incorrect:
 - a. Remove the plug from the socket.
 - b. Open the plug and switch 2 of the 3 phases in the plug. This should only be carried out by suitably qualified personnel.

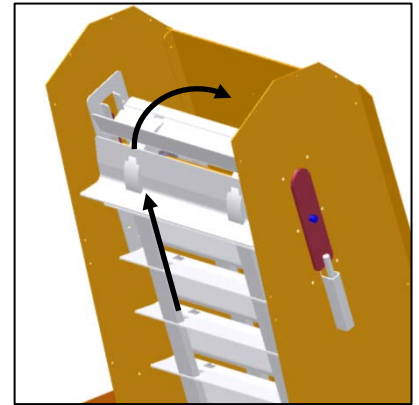

5.5 Check elevator chain tension



Check the elevator chain tension before you start working with the machine.

Procedure:

1. Check the elevator chain tension. The correct tension is obtained when the chain in the middle deflects $\pm 10\text{mm}$.
2. Adjust the chain tension if necessary .
 - a. The tension can be adjusted using the two clamping nuts, located on opposite sides of the elevator housing.
 - b. Tighten the nuts (A) on both sides of the elevator equally.

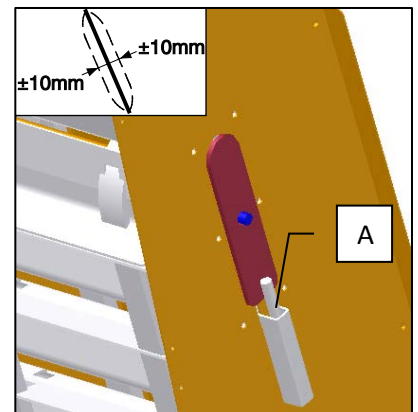

The tension of the chain should not be too tight.

5.6 Check substrate conveyor tension



Check the substrate conveyor belt tension before you start working with the machine.

Procedure:

1. Check the substrate conveyor belt tension. The correct tension is obtained when the belt in the middle deflects $\pm 40\text{mm}$.
2. Adjust the belt tension if necessary .
 - a. Loosen the four screws (B) to the block bearings.
 - b. The tension can be adjusted by simultaneously turning both sides of the ground belt (A).
 - c. Tighten the four screws (B) to the block bearings.

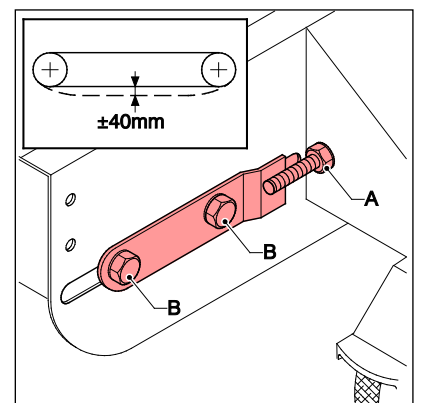

5.7 Set substrate conveyor speed



Set the substrate conveyor speed before you start working with the machine.

Procedure:

1. Check the substrate conveyor speed. Set the speed in this way that trays are being filled sufficiently before they reach the substrate slide.



Adjust the speed of the conveyor belt as slowly as possible. Do not add more soil than necessary.



Adjust the speed of the conveyor belt only when engines are running.

2. When the speed needs to be adjusted:
 - a. Loosen locking bar (A).
 - b. Turn wheel (B):
 - i. CCW = substrate conveyor speed is increased.
 - ii. Clockwise = the speed of the conveyor will run slower.
 - c. Tighten locking bar (A).

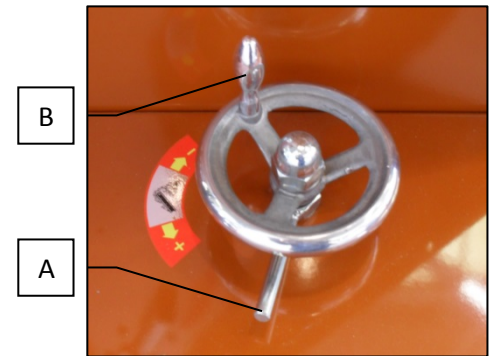

5.8 Set speed, rotation direction and rotation speed of the string conveyors



Set the speed, rotation direction and rotation speed of the string conveyors before you start working with the machine.

Procedure:

1. Check the speed of the string conveyors. Set the speed in a way that all pots are sufficiently filled before they reach the wipers.
2. When the speed needs to be adjusted, use two potentiometers at the main cabinet to adjust speed, rotations direction and rotation speed.

5.9 Set the wipers position



Set the wipers position before you start working with the machine.

The wipers will wipe topside of the pot smoothly when set at the correct height and position.

Procedure:

1. Loosen the clamps.
2. Set wipers in a way that they reach the top of the pot and do not touch the stem.
3. Set the string conveyors in a way that pots will rotate sufficiently so that pots are wiped all the way around the pot.

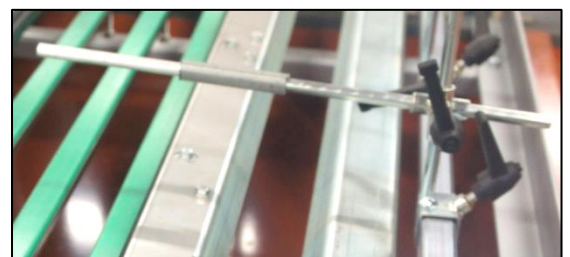

5.10 Set the width of the string conveyors



Set the width of the string conveyors before you start working with the machine.

Procedure with fixed string conveyor position at elevator side:

1. Loosen clamp (A) on both sides of the string conveyors.
2. Adjust the width of the conveyor belts with lever (B). The width of the string conveyance path (C) is now adjusted.
3. Tighten clamp (A) on both sides of the string conveyors.

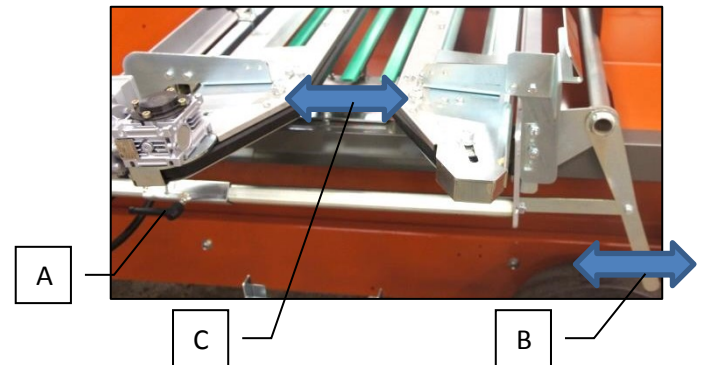

There is also a possibility to set the two string conveyors relative to the heart of the conveyor path.

5.11 Fill substrate bin



Fill the substrate bin before you start working with the machine.

Before starting the machine, the bottom level in the substrate bin must be at least 14 inches above the substrate belt for proper operation.

6 Operation



Follow all instructions described in this manual, in particular chapter safety.



Keep hands, hair, loose clothing and / or jewelry away from moving parts of the machine. Wear appropriate clothing without loose parts. Wear non-slip work shoes.



As long as the machine is on, no connection or safety devices may be removed. The machine may only be used when all protective devices and safety-related facilities are available and ready for use.



If a machine part is damaged or not working in the prescribed manner, work must be interrupted immediately. Resumption allowed only when the machine part is repaired or replaced and checked. Consult your dealer if the machine is not functioning properly.

6.1 Start

Start procedure:

1. Turn on the main power at the electrical cabinet (A).
2. Turn on the elevator with switch (B) at the electrical cabinet.
3. Turn on the string conveyors with switch (C) at the electrical cabinet.
4. Set the speed, rotations speed and rotation direction with potentiometers (D) and (E) at the electrical cabinet.
5. Press the blue reset button (C).
6. Press the green button (A) on the control panel to start the machine.

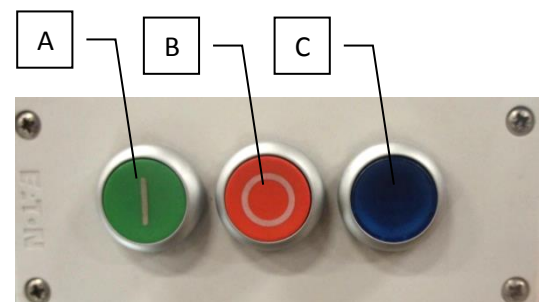
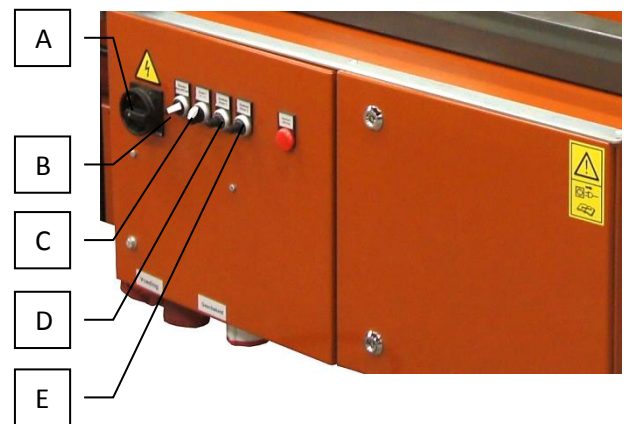

6.2 Stop

Stop procedure:

1. Press the red stop button (B) on the control panel.

6.3 Emergency stop

Emergency stop procedure:

1. Press the red emergency stop button on the machine to activate the emergency stop.

Restart after emergency stop procedure:

1. Ensure that the cause of the emergency is resolved.
2. Close all doors and covers.
3. Pull the red emergency stop button to reset.
4. Press the reset button.
5. Press the green button on the control panel to start the machine.



7 Maintenance



Follow all instructions described in this manual, in particular chapter safety.



Maintenance of this machine must be performed in compliance with warnings on the machine and in accordance with the user manual by qualified personnel.



Keep hands, hair, loose clothing and / or jewelry away from moving parts of the machine. Wear appropriate clothing without loose parts. Wear non-slip work shoes.



As long as the machine is on, no connection or safety devices may be removed. The machine may only be used when all protective devices and safety-related facilities are available and ready for use.



Always unplug the plug from the socket before starting maintenance. Wear personal protective equipment (see section 2.3).



Inform operating personnel before start maintenance. Interrupt if possible the power (mains), before the machine is investigated or maintained by turning off the main switch and locking it and pull the plug from the socket. If work must be done with power supply (mains) voltage on the machine, work with an additional person who can operate the emergency stop.

7.1 Required tools and equipment

A set of keys is included with the machine, consisting of:

- A. Door key
- B. Spanner 24-27mm
- C. Spanner 17-19mm
- D. Spanner 10-13mm

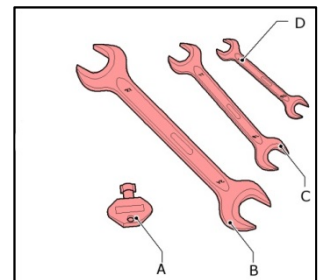

7.2 Preventive Maintenance

For the following maintenance instructions normal use is considered. With heavy use, or use under extreme conditions, maintenance should be performed at shorter intervals.

Item	1x per...	Comments
Machine	Day	Check if moving parts are functioning correctly and not clamping and / or parts are broken or damaged in such a way that the operation is adversely affected. Have damaged parts repaired before use.
Materials in the machine	Day	Remove trays or other material that has fallen into the machine before starting the machine.
Elevator chain	Day	Check tension. See section "Mounting, installation and commissioning".
Elevator	Month	Cleaning. See section "Elevator cleaning".
Safety components	Week	Test the safety circuit. See section "Test safety circuit".
Pictograms	Week	Check readability and replace if necessary.
Electrical installation	Year	Check for damage.
Electric motors	Year	Remove dust.

7.3 Elevator cleaning

Procedure:

1. Turn off the machine and remove plug from socket.
2. Remove protective cover (A) and (B) at the backside of the elevator by opening lock (C) and (D).
3. Clean the blades with compressed air or a dry brush.
4. Install the protective cover on the machine.

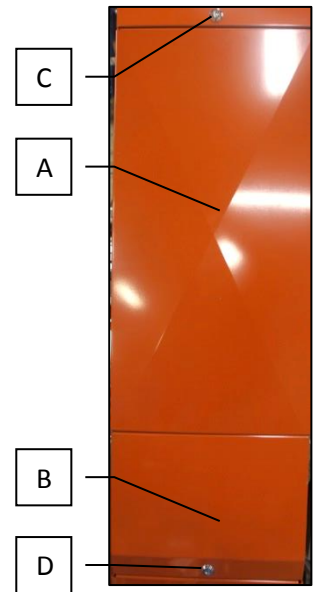

7.4 Test safety circuit

Procedure:

1. Start the machine.
2. Press the emergency stop button. The machine is now disabled.
3. Pull the Emergency Stop button. The machine remains off.
4. Press the reset button emergency stop circuit. All possibly connected conveyors start moving.
5. Start the machine



The machine must not be used when going through the above process, the machine responds differently than described above. Warn directly Javo BV.

7.5 Fault list

Problem	Possible cause	Action / Solution
Motor fault	mains voltage deviates more than 10% of the rated motor voltage	Provide the correct voltage
	Too high cooling air temperature	Provide cool air
	Poor cable connection	check the cable connection and repair if necessary
	Blown fuse	Replace fuse
	Too little cooling air caused by a clogged cooling air passage	Ensure proper inlet and outlet of the cooling air
The motor hums and takes too much power	Defect winding	Repair or replace the motor winding
Fuses are blown	Motor fault	Call a mechanic
	Mechanical blockage of pottrack, elevator	Remove blockages
	Motor is connected incorrectly	Connect the motor correct
Substrate conveyor is not moving	The motor or mechanical drive is not functioning	Check motor and drive mechanism
	Conveyor tension is too low (belt slipping)	Increase conveyor belt tension
	Fault at the inverter	Check inverter manual if there is a fault code shown at the inverter

Problem	Possible cause	Action / Solution
String conveyors are not moving	Super grip belt is slipping	Increase conveyor belt tension
		Align string drives (pulleys)
		Clean string drives
The elevator chain does not move	Obstacles in chain	Remove obstacles
	Ground freezes in elevator	Remove excess soil from elevator paddles
Machine does not start	Emergency stop button is not pulled	Pull Emergency Stop button and reset the safety circuit by pressing the reset button
	Emergency stop button not reset	Reset the safety circuit by pressing the reset button
	Breaker tripped in main cabinet	See why circuit breaker has tripped. Remove obstacles to conveyors. Switch on the machine after solving the problem.
	Cable length too large causing voltage loss	Reduce cable length
	Voltage fluctuations caused by other devices on the same group	Ensure the correct voltage. Turn off other devices
	A second machine in line is not ready	Check second machine.
Amount of soil provided is not enough	Soilslide is set too low.	Set the soil slide higher.
	Soilslide is set too low and a tunnel is build up above the soil conveyor.	Set the soil slide higher.
	belt slipping.	Check conveyor tension.
No soil provided	Elevator is stuck	Move elevator back and forwards and decrease the soil supply.

7.6 Drawings and schemes

The drawings accompanying this machine are supplied in a separate file. The wiring diagrams are included in the electrical cabinet of the machine.

7.7 Spare parts

Only original spare parts and accessories of Javo BV may be used on the machine.

Javo BV advises you to take certain parts in stock because of wear sensitivity and / or any expected downtime for re-ordering of the parts.

The spare parts list can be found on the assembly drawings. These can be found on JavoNet.

When ordering (spare) parts at Javo BV, the following information must be included: drawing number, item number, desired length (if applicable) and the desired number of pieces.

7.8 JavoNet

We recommend you to register your machine on JavoNet. This way you get online access to all technical drawings and documents pertaining to your machine.

Visit our website (www.javo.eu) for more information and to request an account.



7.9 Customer support and advice

Our technical department will answer your other questions about repair and maintenance of your machine and spare parts. We can help you with any questions regarding the purchase, use and settings of products and accessories.

8 Disposal of machine or machine parts



Follow all instructions described in this manual, in particular chapter safety.

Perform the following steps when disposing the machine:

1. Decommission the machine and remove electric and pneumatic power.
2. Drain and remove all consumables.
3. Scrap the machine according to the local legislation.

9 EG-conformity statement

EG-conformity statement for machines (directive 2006/42/EG, annex II, under A.)



Javo BV
 Westeinde 4
 2211XP Noordwijkerhout
 The Netherlands

Declares that:

Machine: **Easytopper**
Type: **Potmachine**

is in accordance with the **Machine directive 2006/42/EG** and complies with the provisions of the **EMC-directive 2004/108/EEG**

Complies with the harmonized European Standards:

Harmonized European standard	definition	Harmonized European standard	definition
NEN-EN-ISO 12100:2010	Safety of machinery - Basic concepts, general principles for design - Part 1: Basic terminology, methodology	NPR-ISO/TR 14121-2:2010	Safety of machinery - Risk assessment - Part 2: Practical guidance and examples of methods
NEN-EN-ISO 13857	Safety of machinery - Safety distances to prevent hazard zones being reached by the upper and lower limbs	NEN-EN 13850	Safety of machinery - Emergency stop - Principles for design
NEN-EN-ISO 13849-1	Safety of machinery - Parts of Control Systems with a safety function - Part 1: General principles for design	NEN-EN-IEC 60204-1	Safety of machinery - Electrical equipment of machines - Part 1: General requirements

The Netherlands, Noordwijkerhout,
 January 2015

Cees Bouwmeester
 Director