

## USER GUIDE

# SCC-ACC01 Accelerometer Input Module

The SCC-ACC01 accelerometer (ACC) input module accepts an active accelerometer input signal, passes it through a 0.8 Hz highpass filter, amplifies it, and then passes it through a 19 kHz lowpass Bessel filter and an output buffer. The module has a fixed gain of 2, so the maximum input range is  $\pm 5$  V. The SCC-ACC01 also provides a 4 mA current source for accelerometer excitation.

## Conventions

---

The following conventions are used in this guide:

<>

Angle brackets that contain numbers separated by an ellipsis represent a range of values associated with a bit or signal name—for example, P0.<3..0>.

»

The » symbol leads you through nested menu items and dialog box options to a final action. The sequence **File»Page Setup»Options** directs you to pull down the **File** menu, select the **Page Setup** item, and select **Options** from the last dialog box.



This icon denotes a note, which alerts you to important information.



This icon denotes a caution, which advises you of precautions to take to avoid injury, data loss, or a system crash. When this symbol is marked on the product, refer to the *Read Me First: Safety and Radio-Frequency Interference* document, shipped with the product, for precautions to take.



When symbol is marked on a product, it denotes a warning advising you to take precautions to avoid electrical shock.



When symbol is marked on a product, it denotes a component that may be hot. Touching this component may result in bodily injury.

<b>bold</b>	Bold text denotes items that you must select in software, such as menu items and dialog box options. Bold text also denotes parameter names.
<i>italic</i>	Italic text denotes variables, emphasis, a cross reference, or an introduction to a key concept. This font also denotes text that is a placeholder for a word or value that you must supply.
monospace	Text in this font denotes text or characters that you should enter from the keyboard. This font is also used for the proper names of disk drives, paths, directories, programs, subprograms, subroutines, device names, functions, operations, variables, filenames, and extensions.
SC-2345	SC-2345 refers to both the SC-2345 connector block and the SC-2345 with configurable connectors.
SCC	SCC refers to any SCC Series signal conditioning module.

# What You Need to Get Started

---

To set up and use the SCC-ACC01, you need the following items:

- SC-2345/2350 with one of the following:
  - SCC-PWR01
  - SCC-PWR02 and the PS01 power supply
  - SCC-PWR03—requires a 7 to 42 VDC power supply (not included)
- One or more SCC-ACC01
- SCC-ACC01 Accelerometer Input Module User Guide*
- Read Me First: Safety and Radio-Frequency Interference*
- SC-2345/2350 User Manual*, available at [ni.com](http://ni.com)
- SCC Quick Start Guide*, available at [ni.com](http://ni.com)
- SC-2345 Quick Reference Label
- 68-pin E Series DAQ device, documentation, and 68-pin cable
- 1/8 in. flathead screwdriver
- Numbers 1 and 2 Phillips screwdrivers
- Wire insulation strippers
- NI-DAQ (current version) for Windows 2000/NT/XP/Me



**Note** Software scaling of measurements is not supported on the Macintosh operating system.

# Device Specific Information

---



**Note** For general SCC module installation and signal connection information, and information about the SC-2350 carrier, refer to the *SCC Quick Start Guide*, available for download at [ni.com/manuals](http://ni.com/manuals).

## Installing the Module



**Caution** Refer to the *Read Me First: Safety and Radio-Frequency Interference* document before removing equipment covers or connecting/disconnecting any signal wires.

You can plug the SCC-ACC01 into any analog input socket on the SC-2345. It can function as a single-stage module or as the first stage of a dual-stage signal conditioning configuration. The socket you choose determines which E Series DAQ device channels receive the SCC-ACC01 signals, as explained in the *Connecting the Input Signals* section.

For single-stage input conditioning, plug the SCC-ACC01 into any socket J(X+1), where X is 0 to 7, and connect the input signals to the module as described in the *Connecting the Input Signals* section.

If you use the SCC-ACC01 in a dual-stage configuration, the SCC-ACC01 must be the first-stage module. Plug it into any socket J(X+9) and plug the second-stage SCC into socket J(X+1), where X is 0 to 7. Connect the input signals to the SCC-ACC01 as described in the *Connecting the Input Signals* section. The SC-2345 connects the output signals of the first-stage SCC to the inputs of the second-stage SCC. An example of dual-stage conditioning is an SCC-ACC01 followed by a lowpass filter module (SCC-LPXX).

Although not available for the SCC-ACC01, sockets J9 to J16 are available for digital input/output conditioning or control with another SCC module. Refer to the *SC-2345/2350 User Manual* for more information on configuring, connecting, and installing SCC modules.

## Connecting the Input Signals



**Note** The signal names have changed. Refer to [ni.com/info](http://ni.com/info) and enter `rdntng` to confirm the signal names.

Each screw terminal is labeled by pin number <1..4>. Pins 1 and 2 form a differential (DIFF) analog input channel for measuring the voltage across the accelerometer. This channel is routed to E Series DAQ device channel X, where X is 0 to 7 depending on the socket where you plug in the SCC-ACC01. Pins 3 and 4 carry the 4 mA constant-current excitation source. Figure 1 shows the SCC-ACC01 signal connections.

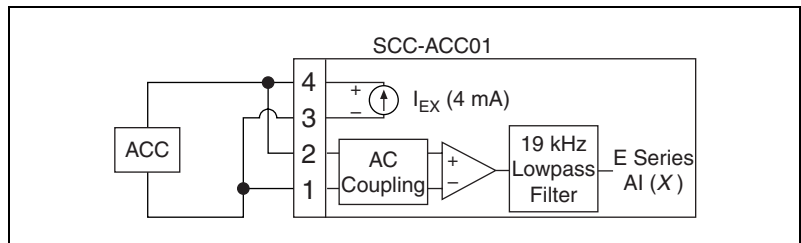

**Figure 1.** SCC-ACC01 Signal Connections

The signal source can be floating or ground-referenced. The SCC-ACC01 input circuitry includes high-impedance bias resistors typically required for floating sources. External bias resistors connected to ground are not required.

For floating signal sources in high-noise environments, connect the negative terminal of the signal source to the AI GND terminal on the SC-2345 screw-terminal block to reduce common-mode noise.

For information about how to configure the SCC-ACC01 module using NI-DAQmx, refer to the *SCC Quick Start Guide*.

## Using the SCC-ACC01

### Scaling Voltage Measurements

If you configured the SCC-ACC01 using Measurement & Automation Explorer (MAX) and are using NI-DAQ, the reading you get from the E Series DAQ device is properly scaled. Use scaling constants obtained from your sensor data sheet to convert the accelerometer voltage to the desired unit, such as newtons,  $m/s^2$ , or g. Otherwise, complete the following steps to scale the readings:

1. Measure the accelerometer voltage.
  - a. Read the accelerometer channel on the E Series DAQ device  $V_{ESERIES}$  (CHX).
  - b. Calculate the accelerometer voltage using this formula:

$$V_{ACC} = V_{ESERIES}/2$$

where

$V_{ACC}$  is the SCC-ACC01 input voltage.

$V_{ESERIES}$  is the E Series DAQ device input voltage.

2. If the module is configured using MAX, use scaling constants obtained from your sensor data sheet to convert  $V_{ACC}$  voltage to the desired unit, such as newtons,  $m/s^2$ , or g.



**Note** Step 1 provides proper scaling for the amplifier in the SCC-ACC01 if the module is not configured using MAX.

## Specifications

---

These ratings are typical at 25 °C unless otherwise stated.

### Analog Input

Number of input channels.....	1 DIFF
Input range .....	$\pm 5$ V (fixed gain of 2)
Input coupling .....	AC (highpass 1-pole RC filter)
-3 dB cutoff frequency .....	0.8 Hz
Filter type.....	Lowpass 3-pole Bessel
-3 dB cutoff frequency .....	19 kHz
Passband flatness .....	$\pm 0.3$ dB, 10 Hz–5 kHz; $\pm 1$ dB, 5 Hz–10 kHz
Input impedance .....	0.39 $\mu$ F in series with 5 M $\Omega$ (powered on or off)
System noise .....	130 $\mu$ V <sub>rms</sub> (referred to input, [RTI]) <sup>1</sup>

---

<sup>1</sup> This specification is calculated relative to the input range of the module.

# Transfer Characteristics

Gain ..... 2

Gain transfer

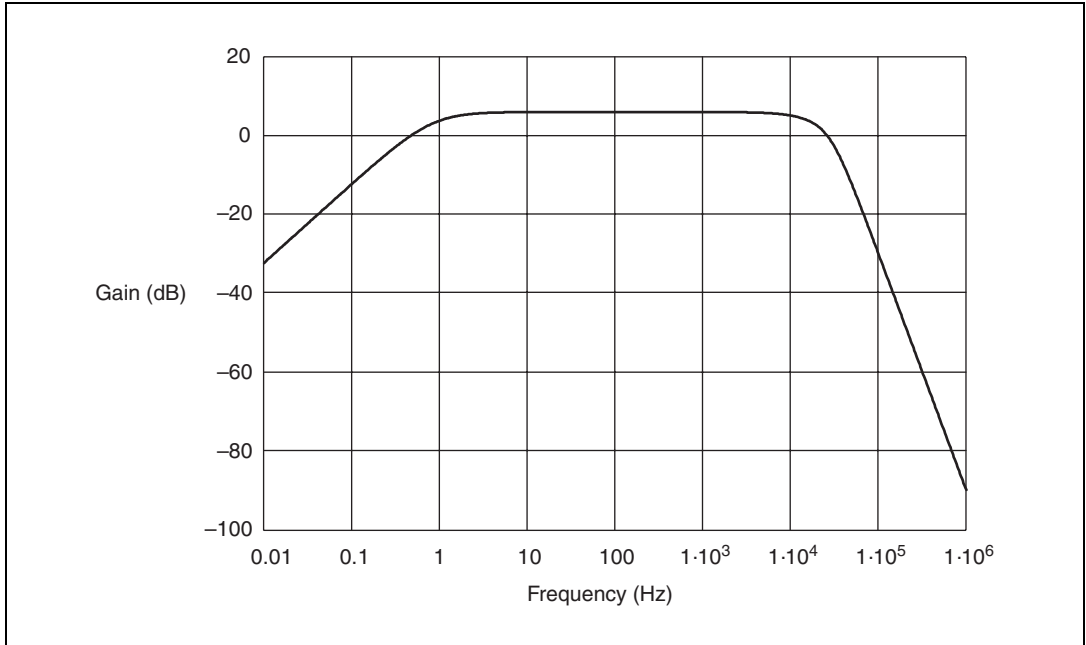

## Phase transfer

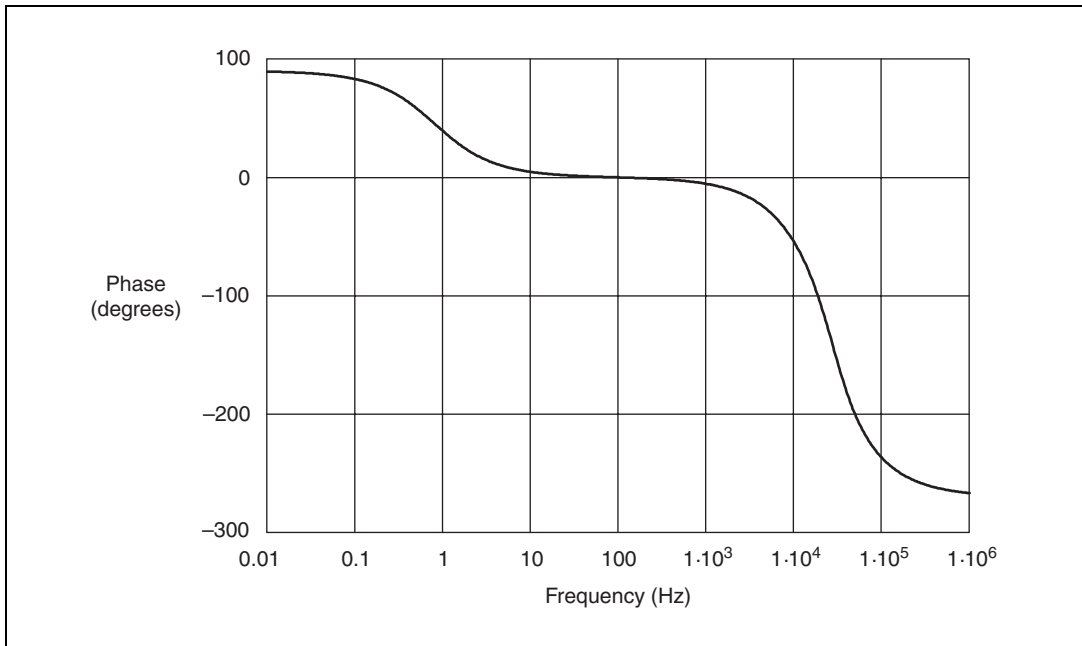

Gain error..... $\pm 1\%$  of reading

Gain-error temperature coefficient ..... $\pm 10$  ppm/ $^{\circ}\text{C}$

Offset error ..... $\pm 3$  mV RTI

Offset-error temperature coefficient ..... $\pm 1.6$   $\mu\text{V}/^{\circ}\text{C}$

Nonlinearity ..... 10 ppm of full scale

Recommended warm-up time.....5 min

## Amplifier Characteristics

Common-mode rejection ratio .....80 dB at 60 Hz

Output range ..... $\pm 10$  V

## Excitation

Number of channels.....1

Constant-current source.....4 mA



Maximum voltage level without losing regulation .....	24 V
Temperature drift .....	$\pm 127$ ppm/ $^{\circ}\text{C}$

## Power Requirement

Analog power .....	89 mW max
+15 V .....	3 mA max
-15 V .....	3 mA max
Digital power .....	420 mW max
+5 V .....	84 mA max

## Physical

Dimensions .....	8.89 cm $\times$ 2.92 cm $\times$ 1.85 cm (3.50 in. $\times$ 1.15 in. $\times$ 0.73 in.)
Mass .....	28.6 g (1.0 oz)
I/O connectors .....	One 20-pin right-angle male connector, one 6-pin screw terminal
Field-wiring diameter .....	28 to 16 AWG

## Maximum Working Voltage

Maximum working voltage refers to the signal voltage plus the common-mode voltage.

Channel-to-earth (inputs) .....	42 VDC, 30 $V_{\text{rms}}$ , Installation Category I
Channel-to-channel (inputs) .....	42 VDC, 30 $V_{\text{rms}}$ , Installation Category I

## Environmental

Operating temperature .....	0 to 50 $^{\circ}\text{C}$
Storage temperature .....	-20 to 70 $^{\circ}\text{C}$
Relative humidity .....	10 to 90%, noncondensing

Maximum altitude.....2,000 m

Pollution Degree (indoor use only) .....2

## Safety

This product is designed to meet the requirements of the following standards of safety for electrical equipment for measurement, control, and laboratory use:

- IEC 61010-1, EN 61010-1
- UL 3111-1, UL 6101B-1
- CAN/CSA C22.2 No. 1010.1



**Note** For UL and other safety certifications, refer to the product label or visit [ni.com/hardref.nsf](http://ni.com/hardref.nsf), search by model number or product line, and click the appropriate link in the Certification column.

## Electromagnetic Compatibility

Emissions.....EN 55011 Class A at 10 m  
FCC Part 15A above 1 GHz

Immunity .....EN 61326:1997 + A2:2001,  
Table 1

CE, C-Tick, and FCC Part 15 (Class A) Compliant



**Note** For EMC compliance, operate this device with shielded cabling.

## CE Compliance

This product meets the essential requirements of applicable European directives, as amended for CE marking, as follows:

Low-Voltage Directive (safety).....73/23/EEC

Electromagnetic Compatibility  
Directive (EMC) .....89/336/EEC



**Note** Refer to the Declaration of Conformity (DoC) for this product for any additional regulatory compliance information. To obtain the DoC for this product, visit [ni.com/hardref.nsf](http://ni.com/hardref.nsf), search by model number or product line, and click the appropriate link in the Certification column.

# SCC-ACC01 Module Pin Assignments

Figure 2 shows the I/O connector pins on the bottom of the module.

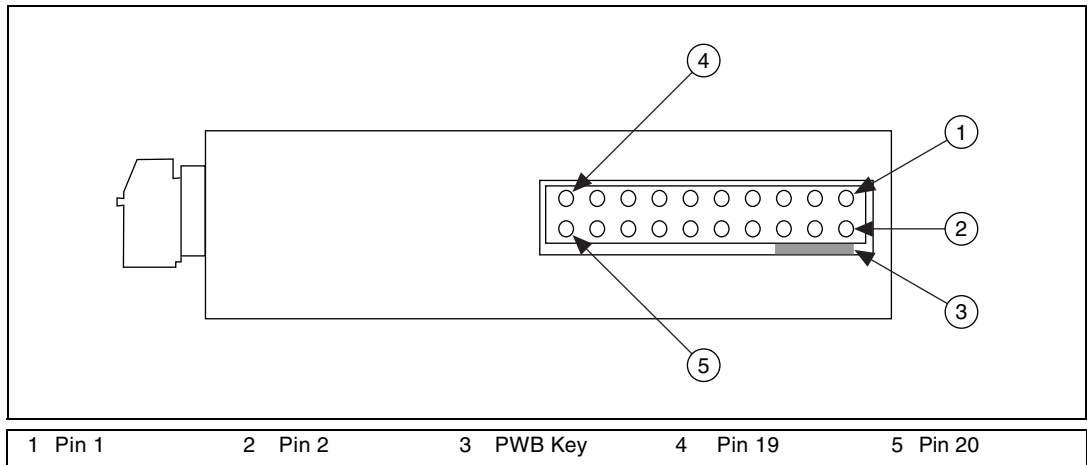

**Figure 2.** SCC Module Bottom View

Table 1 lists the signal corresponding to each pin. AI ( $X$ ) is an analog input signal channel of the E Series DAQ device. AI GND is the analog input ground signal and is the reference for AI ( $X$ ). A GND is the reference for the  $\pm 15$  V supplies and REF 5 V. AI GND and A GND connect to the SC-2345 at the SCC-PWR connector. GND is the reference for the +5 V supply.

**Table 1.** SCC-ACC01 Module Pin Assignments

Pin Number	Signal
1	E Series AI ( $X$ )
2	E Series AI GND
3	—
4	—
5	—
6	E Series AI GND
7	—
8	E Series AI GND
9	+5 V
10	GND

**Table 1.** SCC-ACC01 Module Pin Assignments (Continued)

<b>Pin Number</b>	<b>Signal</b>
11	A GND
12	—
13	+15 V
14	-15 V
15	—
16	—
17	—
18	—
19	—
20	—

National Instruments™, NI™, ni.com™, and NI-DAQ™ are trademarks of National Instruments Corporation. Product and company names mentioned herein are trademarks or trade names of their respective companies. For patents covering National Instruments products, refer to the appropriate location: **Help»Patents** in your software, the `patents.txt` file on your CD, or [ni.com/patents](http://ni.com/patents).

© 2002–2004 National Instruments Corp. All rights reserved.



371070B-01

Mar04