

TANNOY®

**VS15 BP
USER MANUAL**

CONTENTS

1. Introduction
2. Unpacking
3. Connectors/Cabling
4. Amplification & Power Handling
5. Crossovers
6. Equalisation/Positioning
7. Dimensions
8. Technical Specifications
9. Rigging & Suspension
 - 9.1 General Safety Advice
 - 9.2 SECUR ET – VTH Pole Mount
 - 9.3 SECUR ET – VEB Eyebolt
10. System Configurations & OEM Controllers
11. VS15BP Service Parts & Accessories
12. Warranty
13. Declaration of Conformity

1. Introduction

The Tannoy VS15BP is a compact, versatile subwoofer system, primarily designed to extend the low frequency response of the V series loudspeakers and increase system headroom.

The VS15BP will extend the frequency response of these systems to below 40Hz and is capable of providing output levels normally be associated with considerably larger enclosures.

The VS15BP comprises one high efficiency 380mm(15") drive unit. The cabinet is constructed from multiple-ply hardwood, which will survive the punishment that speaker systems are subjected to on the road and in club installations. The compact dimensions of the V15BP enable it to be used in permanent or portable applications without being obtrusive.

The VS15BP features recessed carrying handles and blank plate for a top-mounted stand socket, which serves as a base for locating the main full range or mid/high speakers in the air. By using 35mm tubing the need for a tripod stand can be eliminated.

2. Unpacking

Every Tannoy VS15BP is carefully inspected before packing. After unpacking your loudspeaker, please inspect for any exterior physical damage, and save the carton and any relevant packaging materials in case the loudspeaker again requires packing and shipping. In the event that damage has been sustained in transit notify your dealer immediately.

3. Connectors/Cabling

The VS15BP is fitted with 4-pole Neutrik Speakon™ connectors. Speakon has the following advantages over EP and XLR type connectors: All terminations are solderless; this makes life easier at the time of installation or when field servicing is required. Contacts will accept 6 sq. mm wires with an outside diameter of up to 15mm and a current rating of 30 Amps. The pins of the 2 Speakon sockets on the input panel are paralleled within the enclosure. Tannoy has adopted the conventional wiring standard for the VS15BP product: -

Pin 1+ is Positive
Pin 1- is Negative

For a worldwide list of Neutrik distributors see <http://www.neutrik.com/>

Cable choice consists mainly of selecting the correct cross sectional area in relation to the cable length and the load impedance. A small cross sectional area would increase the cables series resistance, inducing power loss and response variations (damping factor).

Connectors should be wired with a minimum of 2.5 sq. mm (12 gauge) cable. This will be perfectly satisfactory under normal conditions. In the case of very long cable runs the wire size should exceed this, refer to the following table for guidance:-

CABLE RUN (m)	C.S.A. OF EACH CONDUCTOR (mm)	CABLE RESISTANCE Ω	% POWER LOSS INTO 8 Ω LOAD	% POWER LOSS INTO 4 Ω LOAD
10	2.5	0.14	1.7	3.5
	4.0	0.09	1.1	2.2
	6.0	0.06	0.73	1.5
25	2.5	0.35	4.3	8.6
	4.0	0.22	2.7	5.4
	6.0	0.14	1.8	3.6
50	2.5	0.69	8.6	17.0
	4.0	0.43	5.4	11.0
	6.0	0.29	3.6	7.2
100	2.5	1.38	17.0	35.0
	4.0	0.86	11.0	22.0
	6.0	0.58	7.2	14.0

4. Amplification & Power Handling

As with all professional loudspeaker systems, the power handling is a function of voice coil thermal capacity. Care should be taken to avoid running the amplifier into clip (clipping is the end result of overdriving any amplifier). Damage to the loudspeaker will be sustained if the amplifier is driven into clip for any extended period of time. Headroom of at least 3dB should be allowed. When evaluating an amplifier, it is important to take into account its behaviour under low impedance load conditions. A loudspeaker system is highly reactive and with transient signals it can require more current than the nominal impedance would indicate.

Generally a higher power amplifier running free from distortion will do less damage to the loudspeaker than a lower power amplifier continually clipping. It is also worth remembering that a high powered amplifier running at less than 90% of output power generally sounds a lot better than a lower power amplifier running at 100%. An amplifier with insufficient drive capability will not allow the full performance of the loudspeaker to be realised.

It is important when using different manufacturers' amplifiers in a single installation that they have very closely matched gains, the variation should be less than +/- 0.5dB. This precaution is important to the overall system balance when only a single active crossover is being used with multiple cabinets; it is therefore recommended that the same amplifiers be used throughout.

5. **Crossovers**

The VS15BP has been designed to be used in conjunction with Tannoy controllers for optimum performance, these provides specific crossover and equalisation functions for the V series combinations as well as combinations of other Tannoy products. Of course the VS15BP is compatible with other OEM controllers/crossovers. For optimum performance please refer to the section on **System Configurations & OEM Controllers**.

6. **Equalisation/Positioning**

The VS15BP is designed to need no equalisation or correction to overcome system limitations. As a result, it will only need equalisation to compensate for difficult acoustic environments.

Excess equalisation can reduce system headroom, and introduce phase distortion resulting in greater problems than it cures. If equalisation is required then it should be applied gently and smoothly. Violent equalisation will be detrimental to the overall sound quality.

The frequency band over which a subwoofer operates is essentially omni-directional, therefore efficiency of the VS15BP may be further enhanced if the unit is placed against a wall, where the radiation in the forward plane will be doubled due to the addition of the reflected rear directed energy, and a 3dB increase in sound pressure will occur. If another boundary is introduced, say a floor, then the effective radiation space is halved again, resulting in a further 3dB lift, and if placed in a corner, once again the sound pressure level will increase by a further 3dB.

7. Dimensions

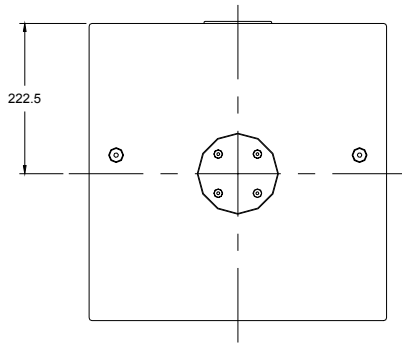
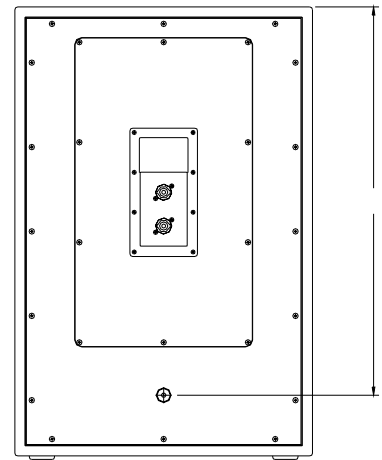
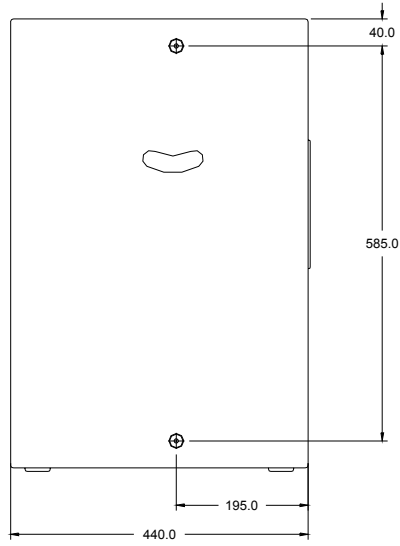
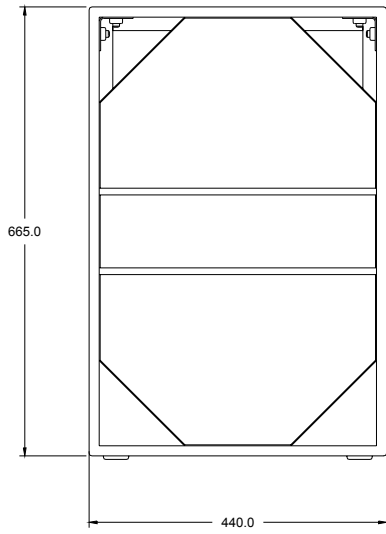

VIEW OF TOP

Vs 15BP

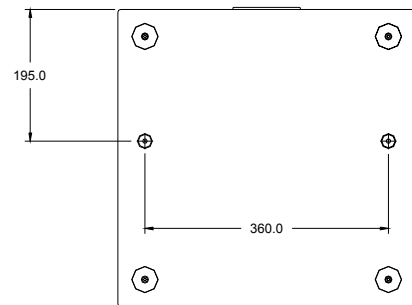

VIEW OF BASE

8. Technical Specifications

Frequency response (1) +/- 3dB	36Hz - 160Hz	
Recommended Amplifier Power	300 - 600 watt / 8 ohm	
Power Handling	Average(2) Programme Peak (10ms) 300 watt 600 watt 1200 watt	
Sensitivity (1) 2.83 volt @ 1m	96 dB 99 dB (half space conditions)	
Maximum SPL (3) @ 1m	Average 124 dB	Peak 130 dB
Impedance	Nominal Minimum	8.0 ohm 7.1 ohm
Distortion		
0.1 Full Power	2nd Harmonic	3rd Harmonic
50 Hz	0.22%	0.71%
100 Hz	0.56%	0.31%
0.01 Full Power	2nd Harmonic	3rd Harmonic
50 Hz	0.21%	0.31%
100 Hz	0.25%	0.18%
Driver Complement	1 x 15" (381mm) LF Driver Type number 3813	
Recommended Crossover Point	80Hz - 160Hz, 24dB/octave Recommended High-pass filter-30Hz, 24dB/octave	
Enclosure	100 litre vented, 15mm (5/8") birch plywood	
Finish	Textured black paint (optional in white)	
Connectors	2 x Speakon NL4MPR IN/OUT	
Fittings	2 x Recessed carrying handles 1 x Blanking plate allows installation of a 35mm pole-mounting socket 8 x M10 flying inserts. 4 x Rubber feet	
Dimensions	665mm(H) x 440mm(W) x 440mm(D) 26 3/16 "(H) x 17 5/16"(W) x 17 5/16"(D)	
Weight	27 Kg (59.4 lbs)	

NOTES:

(1) Average over stated bandwidth. Measured at 1m on axis, in an anechoic chamber.

(2) Long term power handling capacity as defined in EIA standard RS - 426A.

(3) Unweighted pink noise input, measured at 1m in half space conditions.

Tannoy operates a policy of continuous research and development. The introduction of new materials or manufacturing methods will always equal or exceed the published specifications which Tannoy reserve the right to alter without prior notice. Please verify the latest specifications when dealing with critical applications.

9. Rigging & Suspension

9.1 General Safety Advice

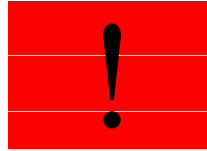

WARNING: As the legal requirements for flying change from country to country, please consult your local safety standards office before installing any product. We also recommend that you thoroughly check any laws and bylaws prior to commencing work. Qualified personnel trained in safe rigging practices should only suspend the system.

Whenever a Tannoy Professional loudspeaker is fixed to a surface using a Tannoy Professional hardware device, the installer must ensure that the surface is capable of safely and securely supporting the load. The hardware employed must be safely and securely, attached both to the loudspeaker and also to the surface in question, using only the fixing holes provided. Secure fixings to the building structure are vital. Seek help from architects, structural engineers or other specialists if in any doubt.

All loudspeakers flown in theatres, nightclubs, conference centre or other places of work and entertainment must, be provided with an independent, correctly rated and securely attached secondary safety – in addition to the principle hardware device. This secondary safety must prevent the loudspeaker from dropping more than 150mm (6”) should the principle hardware device fail.

Threaded inserts are fitted to the VS15BP to allow the suspension of a single enclosure. Never suspend one enclosure from another to form an array or cluster using only these fittings.

If eyebolts are being used then only forged shoulder eyebolts should be used with a thread length of 30mm (see section 8.3).

9.2 SECUR – ET VTH Pole Mount

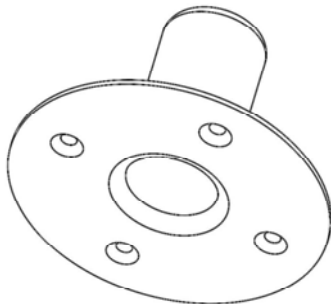

The Tannoy VS15BP loudspeaker is fitted as standard with a blanking plate on top of the cabinet. However, should you ever wish to mount a V series cabinet above the VS15BP using standard 35mm tube, this blanking plate can be quickly and easily removed and replaced by a VTH pole mount. The same screws that secure the blanking plate should be used to secure the VTH in position.

9.3 SECUR ET – VEB Eyebolt

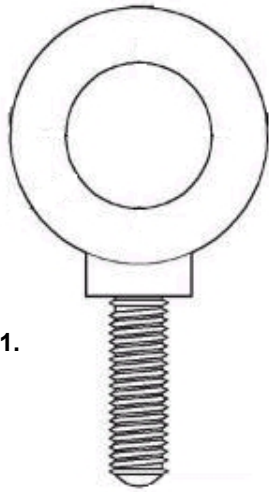

FIG 1.

The Tannoy VS15BP loudspeaker can be flown with high quality VEB M10 eyebolts with collar to BS4278:1984. The loudspeaker is equipped with internal steel braces, which also double as the flying points, and accept VEB M10 eyebolts.

To install the VEB M10 eyebolts remove the original M10 counter sunk screws from the locations you wish to install the VEB M10 eyebolts. Then replace these counter sunk M10 screws with the VEB M10 eyebolts.



Important: It is imperative for safety reasons that two eyebolts linked to two independently fixed straps are used per cabinet. VEB eyebolts should be installed into the relative sides of the cabinet, and should NEVER be installed on the top of the cabinet. Never suspend one enclosure from another to form an array or cluster using these fittings.

Never attempt to use formed eyebolts i.e. formed from a steel rod and bent into an eye.

10. System Configurations & OEM Controllers

With the vast array of digital loudspeaker management systems available it is inevitable that the user may opt to use a controller other than a Tannoy controller as part of a large scale integrated system. The VS15BP has been designed to need no external equalisation to overcome system limitations. Below is a list of recommended parameters; these parameters can be further tailored depending on the acoustic environment or specific application:-

Parameter	Unit/Name	
Gain	(dB)	User definable
Delay	(ms)	User definable
Polarity		Positive
HPF	Freq (Hz)	30
	Slope (dB/oct)	24
	Filter Shape	Butterworth
LPF	Freq (Hz)	80 – 160
	Slope (dB/oct)	24
	Filter Shape	Butterworth
PEQ 1	Freq (Hz)	40
	Level (dB)	+4
	Type	Parametric
	Q / Bandwidth	2.0 / 0.5

11. VS15BP Service Parts & Accessories

Part Number	Description
7900 0596	Driver Kit - 3813
7900 0600	Recone Kit - 3813
8001 2860	VTH – Secur ET – Top Hat (Black)
8001 2870	VTH – Secur ET – Top Hat (White)
8001 2820	VEB – Secur ET – Eyebolts M10

12. Warranty

No maintenance of the VS15BP loudspeaker is necessary.

All Tannoy professional loudspeaker products are covered by a 5 year warranty from the date of manufacture subject to the absence of misuse, overload or accidental damage. Claims will not be considered if the serial number has been altered or removed. A Tannoy Professional dealer or service agent should only carry out work under warranty. This warranty in no way affects your statutory rights. For further information please contact your dealer or distributor in your country. If you cannot locate your distributor please contact Customer Services, Tannoy Ltd at the address given below.

Customer Services
Tannoy Ltd.
Rosehall Industrial Estate
Coatbridge
Strathclyde
ML5 4TF
Scotland

Telephone: 01236 420199 (National)
+44 1236 420199 (International)
Fax: 01236 428230 (National)
+44 1236 428230 (International)
E-Mail: prosales@tannoy.com

DO NOT SHIP ANY PRODUCT TO TANNOY WITHOUT PREVIOUS AUTHORISATION

Our policy commits us to incorporating improvements to our products through continuous research and development. Please confirm current specifications for critical applications with your supplier.

13. Declaration of Conformity

The following apparatus is/are manufactured in the United Kingdom by Tannoy Ltd of Rosehall Industrial estate, Coatbridge, Scotland, ML5 4TF and conform(s) to the protection requirements of the European Electromagnetic Compatibility Standards and Directives relevant to Domestic Electrical Equipment. The apparatus is designed and constructed such that electromagnetic disturbances generated do not exceed levels allowing radio and telecommunications equipment and other apparatus to operate as intended, and, the apparatus has an adequate level of intrinsic immunity to electromagnetic disturbance to enable operation as specified and intended.

Details of the Apparatus: Tannoy Contractor Loudspeaker
Model Number: VS15BP

Associated Technical File: EMCVS15

Applicable Standards: EN 50081-1 Emission
EN 50082-1 Immunity

Signed:



Position: Engineering Director
Tannoy Professional

Date: 4th May 2003

For Tannoy Ltd



Tannoy United Kingdom | T: +44 (0) 1236 420199 | F: +44 (0) 1236 428230 | E: enquiries@tannoy.com
Tannoy North America | T: (519) 745 1158 | F: (519) 745 2364 | E: inquiries@tannoyna.com

Tannoy adopts a policy of continuous improvement and product specification is subject to change.

tannoy[®].com