

Quick reference guide

# Leksell® Multi Purpose Stereotactic Arc

## Introduction

This is a quick reference guide for Leksell® Multi Purpose Stereotactic Arc. It is the user's responsibility to be fully informed of its proper use. For detailed instructions read Leksell® Multi Purpose Stereotactic Arc, Instructions for Use.

Leksell® Multi Purpose Stereotactic Arc is part of Leksell Stereotactic System®, which is intended for localization and diagnosis of intracranial disorders and their surgical treatment including radiosurgery and stereotactic radiation therapy.

## Caution

The user must read and fully understand the Hazard Notices and other Notices contained in Leksell® Multi Purpose Stereotactic Arc, Instructions for Use.

## Names and abbreviations

**Arc** = Leksell® Multi Purpose Stereotactic Arc

**Frame** = Leksell® Coordinate Frame G

## Main Parts

- |  |                                  |
|--|----------------------------------|
| <b>1</b> Semicircular arc                  | <b>6</b> Axis support            |
| <b>2</b> Instrument carrier                | <b>7</b> Arc axis – engraved     |
| <b>3</b> Instrument stop holder – engraved | <b>8</b> Arc axis                |
| <b>4</b> Instrument guide holder           | <b>9</b> Arc supports – engraved |
| <b>5</b> Axis support – engraved           | <b>10</b> Slides                 |
|  | <b>11</b> Instrument screwdriver |

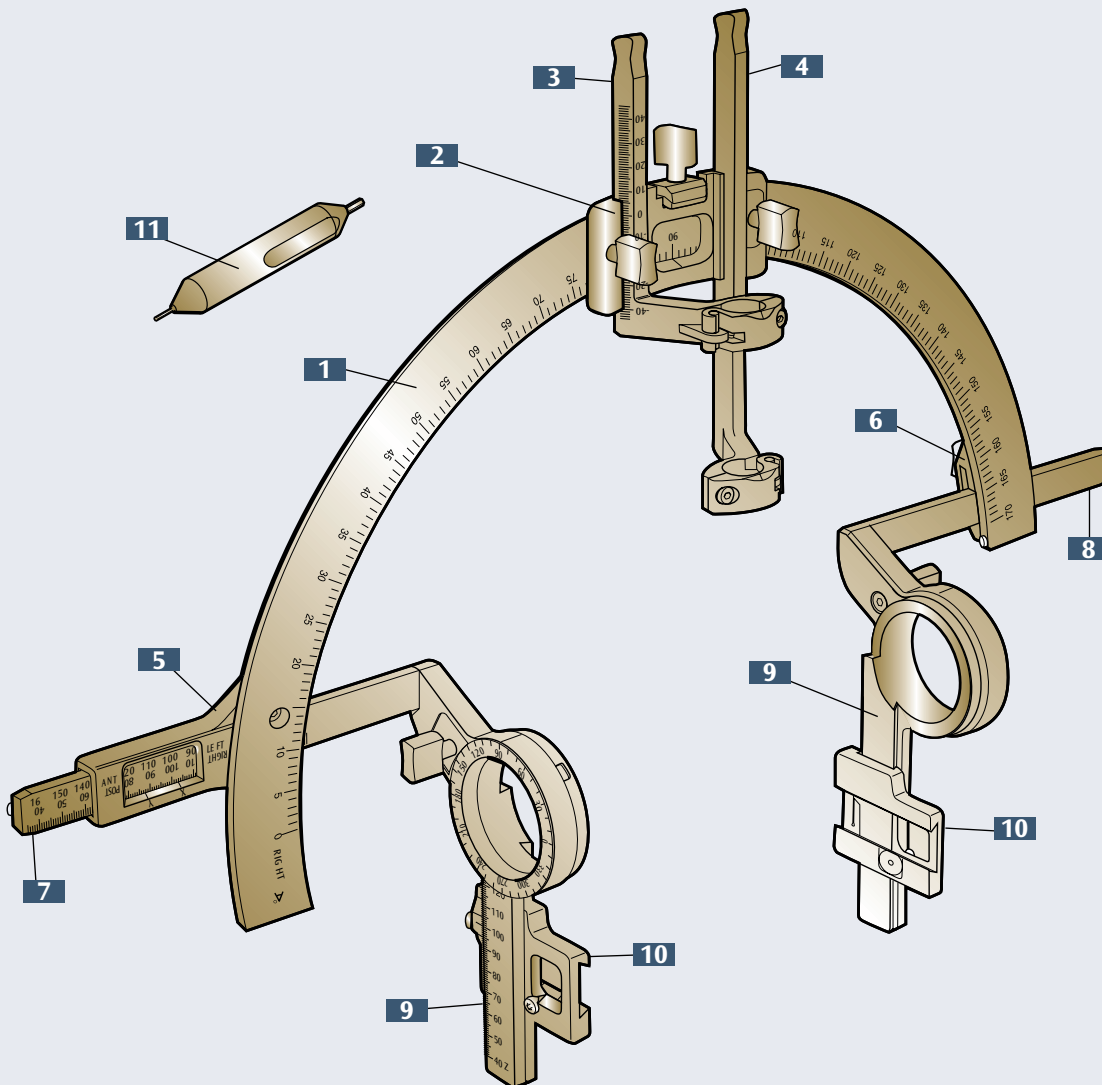

ELEKTA

## Arc orientations

### Lateral right orientation

- The engraved arc axis is on the patient's **right** side.
- The engraved surface of the arc faces **anterior**.
- The **X** coordinate is set on the **RIGHT** scale.

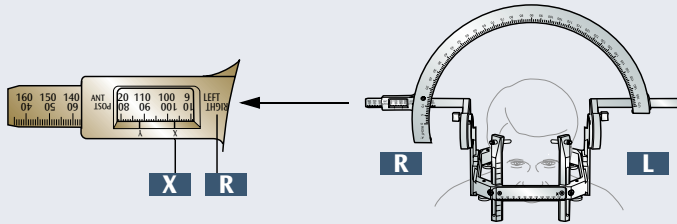

### Lateral left orientation

- The engraved arc axis is on the patient's **left** side.
- The engraved surface of the arc faces **posterior**.
- The **X** coordinate is set on the **LEFT** scale.

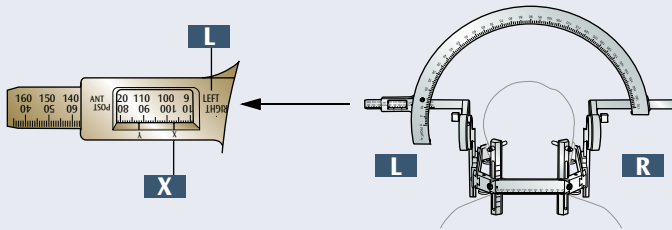

### Sagittal posterior orientation

- The engraved arc axis is at the patient's **posterior**.
- The engraved surface of the arc faces the patient's **right** side.
- The **Y** coordinate is set on the **POST** scale.

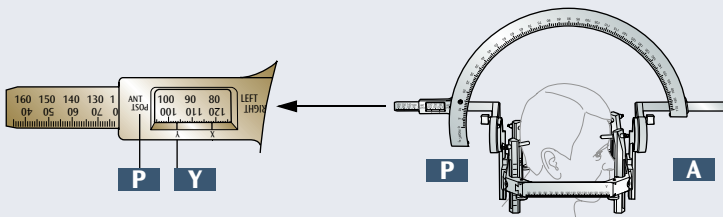

### Sagittal anterior orientation

- The engraved arc axis is at the patient's **anterior**.
- The engraved surface of the arc faces the patient's **left** side.
- The **Y** coordinate is set on the **ANT** scale.

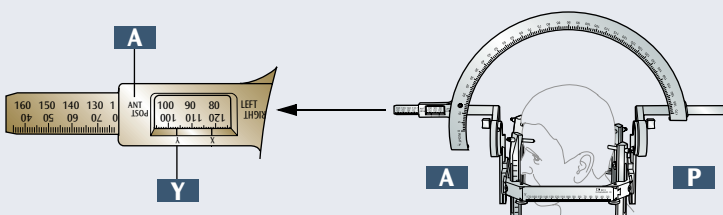

## Assembling – lateral arc orientations

### Fitting arc supports and setting Z coordinate

1. Insert an arc support **9** in a slide **10**
2. Move support and align the required Z coordinate exactly with the index mark **12**
3. Secure the arc support at the required Z coordinate.

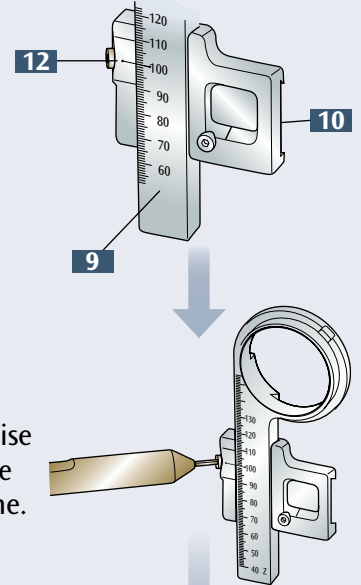

### NOTE

Do not overtighten the screw to secure Z coordinate. Otherwise it may be difficult to move slide and arc support along the frame.

4. Fit and secure the other arc support in the slide in the same manner.

### Fitting slides and setting Y coordinate

1. Insert a slide (with arc support) **10** over the groove of a side bar.

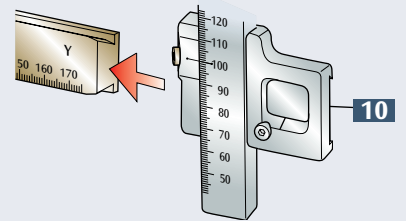

2. Move the slide and align the required Y coordinate exactly with the vertical index mark **13**

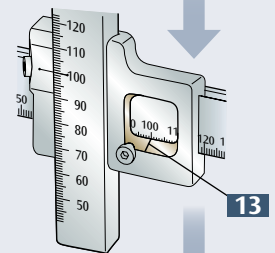

3. Secure the slide with the instrument screwdriver.
4. Fit and secure the other slide with arc support.

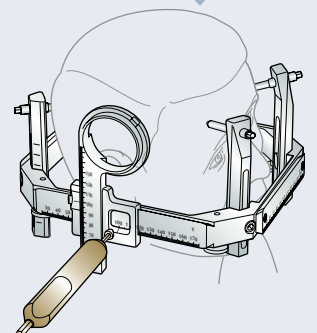

## Fitting arc axis and setting X coordinate

### NOTE

If the arc axis holders have been disassembled ensure that both have been properly remounted. There should be no gap **15** between them and the back surface of the arc.

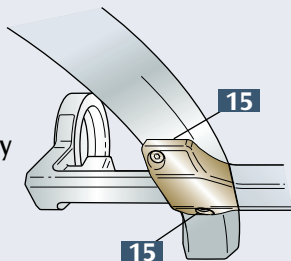

1. Loosen thumbwheel at back of unmarked axis support and slide unmarked axis to open position.

2. Move the engraved arc axis and align the required X coordinate exactly with the X index mark.

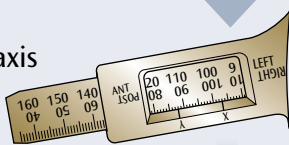

### NOTE

Make sure to use correct scale.

3. Secure the arc axis by tightening the screw **14** on the engraved face with the instrument screwdriver.

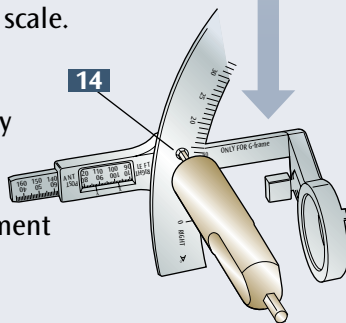

## Fitting the arc and setting the ring angle

1. Align the arc correctly with the frame.
  - Lateral right orientation – the engraved arc axis must mate with the arc support ring on the patient's **right side**.
  - Lateral left orientation – the engraved arc axis must mate with the arc support ring on the patient's **left side**.

2. Introduce the ring of the engraved arc axis into the annulus of the ring on the arc support.

Ensure the small tab fits into the corresponding indent.

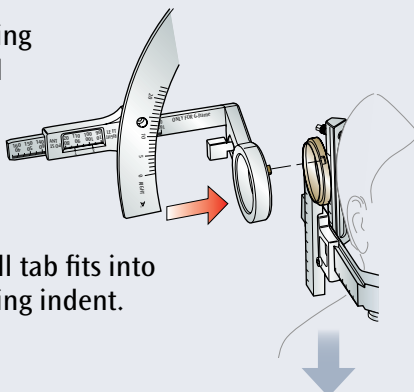

3. Fit the ring of the unmarked arc axis into the ring of the other arc support.

Ensure the small tab fits into the corresponding indent.

4. Carefully push the unmarked arc axis inwards and hold it firmly. Tighten thumbwheel on back of unmarked arc axis with other hand to secure the unmarked arc axis in place. Make sure there is no narrow opening **16**

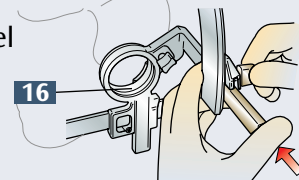

5. Release the thumbwheel at the ring on each arc axis.

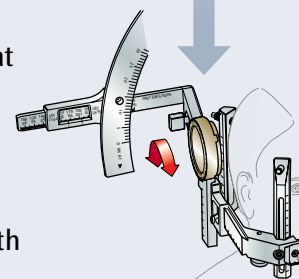

6. Tilt the arc until the index mark is exactly aligned with the desired ring angle.

7. Tighten the thumbwheels on both arc axis to secure the arc at the desired ring angle.

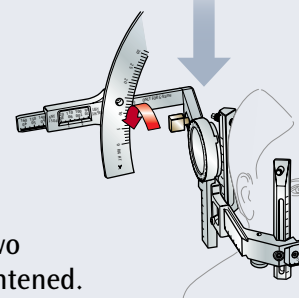

### NOTE

It is very important that the two thumbwheels are properly tightened.

## Assembling – sagittal arc orientations

### NOTE

For sagittal orientations use a straight or slotted front piece – not a curved one.

Assembling of the arc for sagittal orientations follows in principal the same workflow as for lateral orientations with some important exceptions.

1. **Setting Z coordinate**

The Z coordinate is set in the same way as for lateral orientations.

The coordinate is set on the arc support.

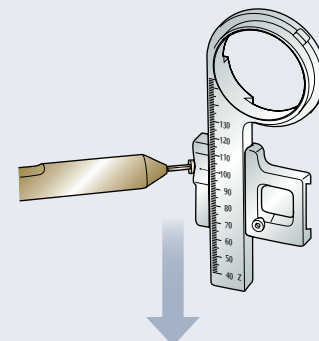

**2. Setting X coordinate**

For sagittal orientations the X coordinate is set before setting the Y coordinate. The X coordinate is set on the front piece and back piece of the frame.

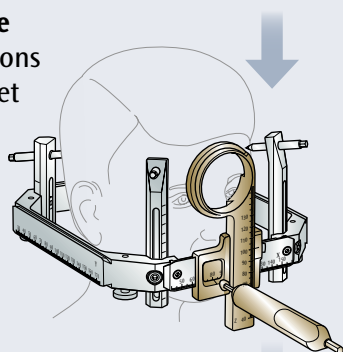

**3. Setting Y coordinate**

For sagittal orientations the Y coordinate is the last coordinate set.

The coordinate is set on the engraved arc axis **7** with the Y index mark.

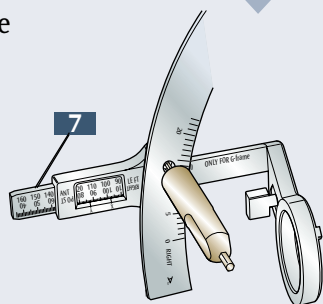

**NOTE**

Make sure to use the correct scale.

**4. Align the arc correctly with the frame.**

- Sagittal posterior orientation – the engraved arc axis must mate with the arc support ring on the patient's **posterior**.
- Sagittal anterior orientation – the engraved arc axis must mate with the arc support ring on the patient's **anterior**.

- 5. Tighten thumbwheel on top to secure the instrument carrier.**

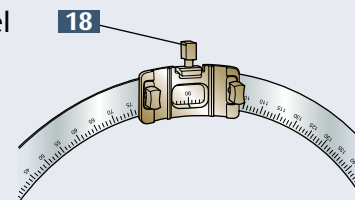

**Fitting the instrument guide and stop holders**

1. Insert the stem of the instrument guide holder **19** into the unmarked slot in the instrument carrier with the collar nearest to the patient's skull.
2. Tighten the thumbwheel to secure the guide holder.
3. Insert the stem of the instrument stop holder **20** in the marked slot of the instrument holder with the collar nearest to the patient's skull.
4. Move instrument stop holder until the horizontal index mark on the carrier is exactly aligned with the desired mark on the stop holder scale.
5. Tighten the thumbwheel to secure the stop holder in place.

- 6. The arc is now fully assembled. The stop insert **21** and guide insert **22** of the selected instrument can now be inserted into the collars. See User's manual for selected instrument!**

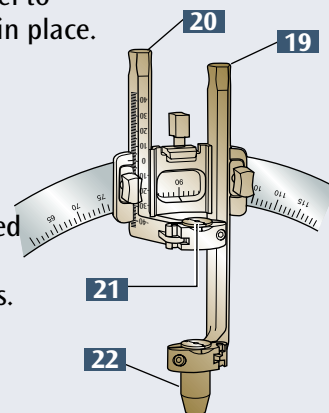

**Fitting the instrument carrier**

**Setting the arc angle**

1. Release locking thumbwheel **18**
2. Attach the instrument carrier to the arc.
3. Ensure that the carrier is correctly oriented so that index mark is visible at the engraved face of the arc.
4. Move the carrier until the desired arc angle is exactly aligned with the index mark.

**Removing of the Arc**

Remove the Arc from the Frame in the reverse of that when securing the Arc.

**Disassembly**

Disassemble the Arc in the reverse of the assembly procedure.

**Care & maintenance**

For detailed instructions read Leksell® Multi Purpose Stereotactic Arc Instructions for Use.