

T1 CSU ACE

Part Number 1202022L1

Document Number 61202022L1-1B

September 2000





901 Explorer Boulevard
P.O. Box 140000
Huntsville, AL 35814-4000
(256) 963-8000

2000 ADTRAN, Inc.
All Rights Reserved
Printed in U.S.A.

FCC regulations require that the following information be provided in this manual:

1. This equipment complies with Part 68 of the FCC rules. On the bottom of the equipment housing is a label that shows the FCC Registration Number and Ringer Equivalence Number (REN) for this equipment. If requested, provide this information to the telephone company. REN is not required for some types of analog or digital facilities.
2. If this equipment causes harm to the telephone network, the telephone company may temporarily discontinue service. If possible, advance notification is given; otherwise, notification is given as soon as possible. The telephone company will advise the customer of the right to file a complaint with the FCC.
3. The telephone company may make changes in its facilities, equipment, operations or procedures that could affect the proper operation of this equipment; advance notification and the opportunity to maintain uninterrupted service is given.
4. If experiencing difficulty with this equipment, please contact ADTRAN for repair and warranty information. The telephone company may require this equipment to be disconnected from the network until the problem is corrected, or it is certain the equipment is not malfunctioning.
5. This unit contains no user-serviceable parts.
6. An FCC compliant telephone cord with a modular plug is provided with this equipment. This equipment is designed to be connected to the telephone network or premises wiring using an FCC-compatible modular jack, which is Part 68-compliant.
7. The following information may be required when applying to the local telephone company for leased line facilities.

Service Type	Digital Facility Interface Code	Service Order Code	Network Jacks
1.544 MB/S Digital Interface SF	04DU9-BN	6.0N	RJ48C
1.544 MB/S Digital Interface ESF	04DU9-DN		
1.544 MB/S Digital Interface ESF with B8ZS	04DU9-1KN 04DU9-1SN		

8. In case of equipment malfunction, all repairs must be performed by ADTRAN or an authorized agent. It is the responsibility of users requiring service to report the need for service to ADTRAN or one of our authorized agents. Service can be facilitated through our office. See the back page of this manual for the address and phone numbers.

Federal Communications Commission Radio Frequency Interference Statement

This equipment has been tested and found to comply with the limits for a Class B digital device, pursuant to Part 15 of the FCC Rules. This device complies with Part 15 of the FCC rules. Operation is subject to the following two conditions:

1. This device may not cause harmful interference,
2. This device must accept any interference received, including interference that may cause undesired operation.



No changes or modifications to this unit are allowed unless expressly approved by the party responsible for compliance. Modifications could void the user's authority to operate the equipment within the FCC rules.

Canadian Emissions Requirements

This digital apparatus does not exceed the Class B limits for radio noise emissions from digital apparatus, as set out in the interference-causing equipment standard entitled "Digital Apparatus," ICES-003 of the Department of Communications.

Cet appareil numérique respecte les limites de bruits radioélectriques applicables aux appareils numériques de Class A prescrites dans la norme sur le matériel brouilleur: "Appareils Numériques," NMB-003 édictée par le ministre des Communications.

Canadian Equipment Limitations

Notice: The Canadian Industry and Science Canada label identifies certified equipment. This certification means that the equipment meets certain telecommunications network protective, operational, and safety requirements. The Department does not guarantee the equipment will operate to the user's satisfaction.

Before installing this equipment, users should ensure that it is permissible to be connected to the facilities of the local telecommunications company. The equipment must also be installed using an acceptable method of connection. In some cases, the company's inside wiring associated with a single line individual service may be extended by means of a certified connector assembly (telephone extension cord). The customer should be aware that compliance with the above limitations may not prevent degradation of service in some situations.

Repairs to certified equipment should be made by an authorized Canadian maintenance facility designated by the supplier. Any repairs or alterations made by the user to this equipment, or equipment malfunctions, may give the telecommunications company cause to request the user to disconnect the equipment.

WARNING

Users should ensure for their own protection that the electrical ground connections of the power utility, telephone lines and internal metallic water pipe system, if present, are connected together. This precaution may be particularly important in rural areas.

WARNING

Users should not attempt to make such connections themselves, but should contact the appropriate electric inspection authority, or an electrician, as needed.

The Load Number (LN) assigned to each terminal device denotes the percentage of the total load to be connected to a telephone loop which is used by the device, to prevent overloading. The termination on a loop may consist of any combination of devices subject only to the requirement that the total of the Load Numbers of all devices does not exceed 100.

IMPORTANT SAFETY INSTRUCTIONS

WARNING

When using telephone equipment, please follow these basic safety precautions to reduce the risk of fire, electrical shock, or personal injury.

1. Do not use this product near water, such as a bathtub, wash bowl, kitchen sink, laundry tub, in a wet basement, or a swimming pool.
2. Avoid using a telephone (other than a cordless type) during an electrical storm. There is a remote risk of shock from lightning.
3. Do not use the telephone to report a gas leak in the vicinity of the leak.
4. Use only the power cord, power supply, and/or batteries indicated in the manual. Do not dispose of batteries in a fire. They may explode. Check with local codes for special disposal instructions.

SAVE THESE INSTRUCTIONS

Warranty and Customer Service

ADTRAN will replace or repair this product within five years from the date of shipment if it does not meet its published specifications or fails while in service. For detailed warranty, repair, and return information refer to the ADTRAN Equipment Warranty and Repair and Return Policy Procedure on the last page of this manual.

Return Material Authorization (RMA) is required prior to returning equipment to ADTRAN.

For service, RMA requests, or further information, contact one of the numbers listed on the last page of this manual.

**Affidavit for the Connection of Customer premises
Equipment to the 1.544 Mbps and /or Subrate Digital
Services.**

For work to be performed in the certified territory of:

Telco's Name: _____

State of: _____

Country of: _____

I, _____, of _____
(Name of Authorized Representative) (Customer Name)

_____, _____
(Customer's Address) (Telephone Number)

being duly sworn, state:

I have responsibility for the operation and maintenance of the terminal equipment to be connected to _____ 1.544 Mbps and/or _____ Subrate digital services. The terminal equipment to be connected complies with part 68 of the commissions rules except for the encoded analog content and billing protection specifications. With respect to encoded analog content and billing protection:

- I attest that all operations associated with the establishment, maintenance and adjustment of the digital CPE with respect to encoded analog content and encoded billing information continuously complies with Part 68 of the FCC's Rules and Regulations.
- The digital CPE does not transmit digital signals containing encoded analog content or billing information which is intended to be decoded within the telecommunications network.
- The encoded analog and billing protection is factory set and is not under the control of the customer.

I attest that the operator(s) maintainer(s) of the digital CPE responsible for the establishment, maintenance and adjustment of the encoded analog content and billing information has (have) been trained to perform

these functions by successfully completing one of the following:
Check appropriate ones(s):

() A. A training course provided by the manufacturer/
grantee of the equipment used to encode analog signals; or

() B. A training course provided by the customer or autho-
rized representative, using training materials and instruc-
tions provided by the manufacturer/grantee of the
equipment used to encode signals; or

() C. An independent training course (e.g., trade school or
technical institution) recognized by the manufacturer/
grantee of the equipment used to encode analog signals; or

() D. In lieu of the proceeding training requirements, the
operator(s) maintainer(s) is (are) under the control of a super-
visor trained in accordance with _____ above.

I agree to provide _____ with proper
documentation _____ (Telco's Name)
to demonstrate compliance with the information as provided in the
proceeding paragraph, if so requested.

_____ (Signature)

_____ (Title)

_____ (Date)

Subscribed and sworn to before me this day _____, month _____,
year _____.

_____ (Notary Public)

My commission expires: _____

LIMITED PRODUCT WARRANTY

ADTRAN warrants that for five (5) years from the date of shipment to Customer, all products manufactured by ADTRAN will be free from defects in materials and workmanship. ADTRAN also warrants that products will conform to the applicable specifications and drawings for such products, as contained in the Product Manual or in ADTRAN's internal specifications and drawings for such products (which may or may not be reflected in the Product Manual). This warranty only applies if Customer gives ADTRAN written notice of defects during the warranty period. Upon such notice, ADTRAN will, at its option, either repair or replace the defective item. If ADTRAN is unable, in a reasonable time, to repair or replace any equipment to a condition as warranted, Customer is entitled to a full refund of the purchase price upon return of the equipment to ADTRAN. This warranty applies only to the original purchaser and is not transferable without ADTRAN's express written permission. This warranty becomes null and void if Customer modifies or alters the equipment in any way, other than as specifically authorized by ADTRAN.

EXCEPT FOR THE LIMITED WARRANTY DESCRIBED ABOVE, THE FOREGOING CONSTITUTES THE SOLE AND EXCLUSIVE REMEDY OF THE CUSTOMER AND THE EXCLUSIVE LIABILITY OF ADTRAN AND IS IN LIEU OF ANY AND ALL OTHER WARRANTIES (EXPRESSED OR IMPLIED). ADTRAN SPECIFICALLY DISCLAIMS ALL OTHER WARRANTIES, INCLUDING (WITHOUT LIMITATION), ALL WARRANTIES OF MERCHANTABILITY AND FITNESS FOR A PARTICULAR PURPOSE. SOME STATES DO NOT ALLOW THE EXCLUSION OF IMPLIED WARRANTIES, SO THIS EXCLUSION MAY NOT APPLY TO CUSTOMER.

In no event will ADTRAN or its suppliers be liable to Customer for any incidental, special, punitive, exemplary or consequential damages experienced by either Customer or a third party (including, but not limited to, loss of data or information, loss of profits, or loss of use). ADTRAN is not liable for damages for any cause whatsoever (whether based in contract, tort, or otherwise) in excess of the amount paid for the item. Some states do not allow the limitation or exclusion of liability for incidental or consequential damages, so the above limitation or exclusion may not apply to Customer.

Table of Contents

List of Figures	xiii
List of Tables	xv
Chapter 1 General	1-1
Unit Overview	1-1
Power Options	1-3
Alarms	1-4
Loopback	1-5
Line Build Out	1-6
Chapter 2 Installation	2-1
Setting the LBO switch positions	2-1
Powering the Unit	2-2
Connecting to The Network and CPE	2-4
Test and Monitor Access	2-5
Monitor Jacks	2-5
Break-and-Test Jacks	2-6
Wall Mounting	2-7
Chapter 3 Troubleshooting and Maintenance	3-1
Troubleshooting	3-1
Power	3-1
Network LOS	3-1
Equipment LOS	3-2
Power On - Self Check Failure	3-2
EPROM Checksum Failure	3-2
Maintenance	3-2
Chapter 4 Specifications	4-1
Network and Customer Interface	4-1
Line	4-1
Data Rate	4-1
Signal Format	4-1
Output Amplitude	4-1
Network Connector Type	4-1

Customer Interface Connector Type	4-1
LED Indicators	4-1
Power	4-1
Net LOS	4-1
Equip LOS	4-1
NET LB	4-1
EQ LB	4-2
Power	4-2
Local Power	4-2
Environmental	4-2
Temperature	4-2
Relative Humidity	4-2
Index	Index-1

List of Figures

Figure 1-1. T1 CSU ACE Applications.	1-1
Figure 1-2. T1 CSU ACE Block Diagram.	1-2
Figure 1-3. T1 CSU ACE Power Supply	1-3
Figure 1-4. T1 CSU ACE LED Alarms	1-4
Figure 1-5. T1 CSU ACE Loopback Switch and LED	1-5
Figure 1-6. Line Build Out Switch	1-6
Figure 2-1. Power Connection	2-3
Figure 2-2. T1 CSU ACE Bantam Jacks	2-5
Figure 2-3. Wall Mounting	2-7

List of Tables

Table 2-1.	Network LBO Switch Position Settings	2-1
Table 2-2.	Customer LBO Switch Position Settings.	2-1
Table 2-3.	Network RJ48C Connector Pin Assignments	2-4
Table 2-4.	CPE Connector Pin Assignments	2-4

UNIT OVERVIEW

The ADTRAN T1 Channel Service Unit (CSU) Advanced Communications Equipment (ACE) provides the T1 interface between customer premises equipment (CPE) such as channel banks, T1 multiplexers, and the carrier network as shown in Figure 1-1. The unit complies with Part 68 of FCC Rules and with applicable sections of AT&T 62411, ANSI T1.102 and ANSI T1. 403.

The unit provides functions such as surge protection, signal regeneration, alarms, loopbacks necessary for circuit operation and fault isolation as illustrated in Figure 1-2 on page 1-2. The unit is transparent to ESF or SF framing formats and AMI or B8ZS line coding.

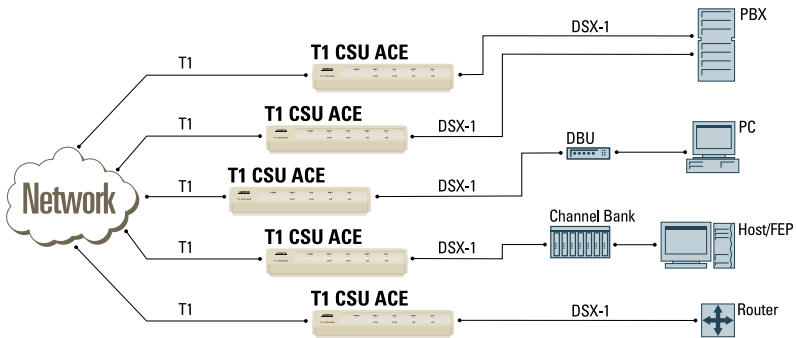

Figure 1-1. T1 CSU ACE Applications

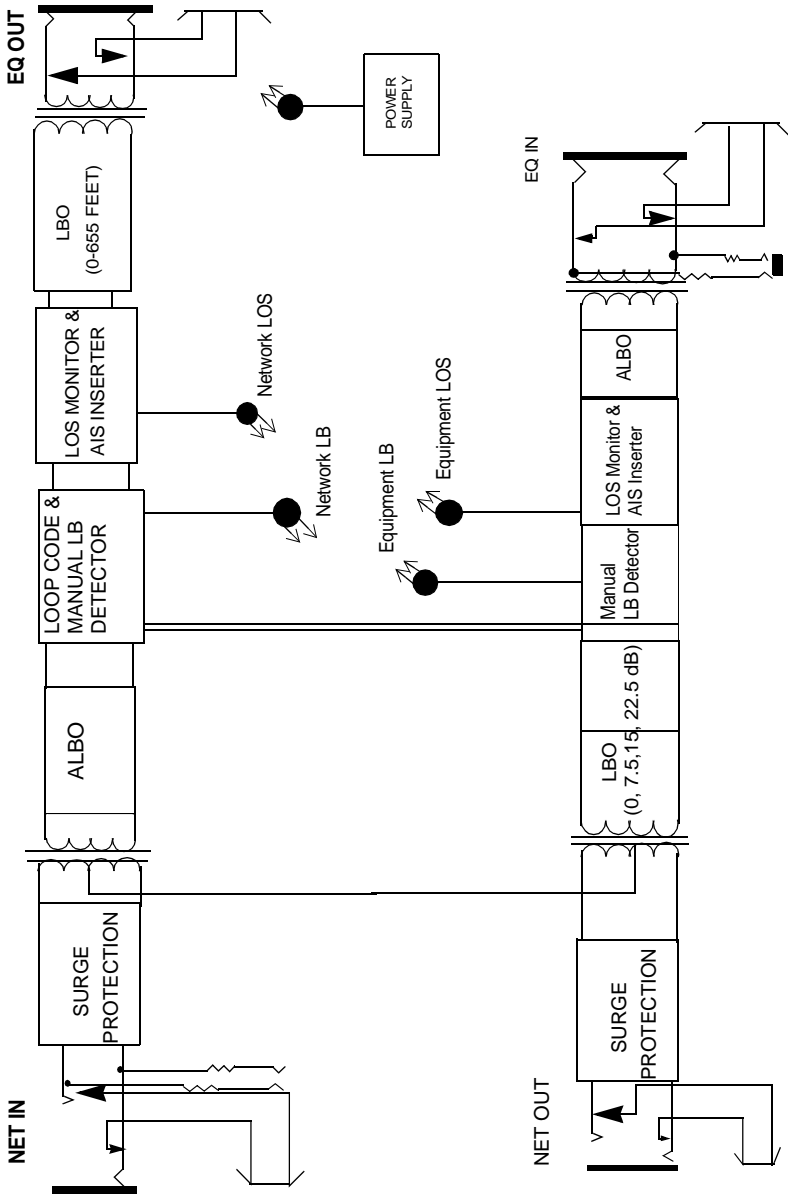

Figure 1-2. T1 CSU ACE Block Diagram

POWER OPTIONS

The T1 CSU ACE may receive power from a local power supply located on the customer's premises. Local power can be supplied by the customer's own 12 to 48-volt supply with the supplied power cable, or by the wall-mount power supply shipped with the unit (see Figure 1-3). The wall mount power supply is an NEC class 2 device.

WARNING

See *Powering the Unit* on page 2-2 for details on connecting the power to the unit.

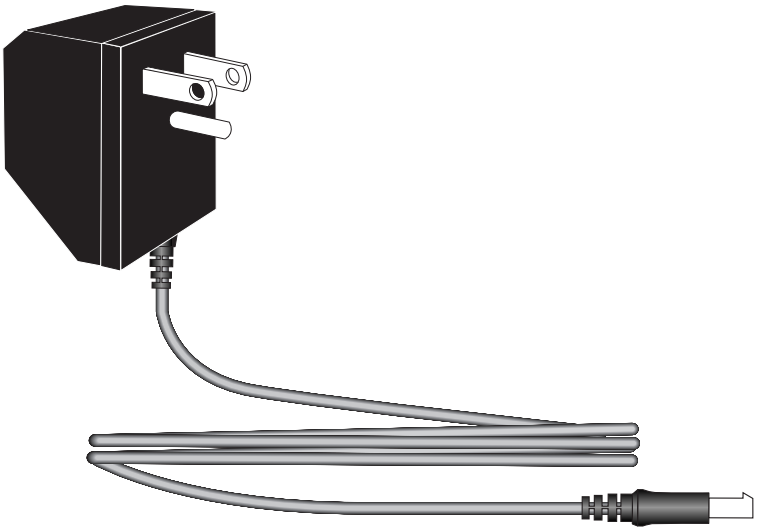

Figure 1-3. T1 CSU ACE Power Supply

ALARMS

The T1 CSU ACE provides five LED alarms on the front of the unit to help troubleshoot the communication channel (See Figure 1-4.) The alarm descriptions are as follows:

- The **POWER** LED shows that the unit is receiving power.
- **NET LOS** indicates loss of signal (LOS) from the network.
- **EQ LOS** is illuminated when a loss of signal from the CPE is detected.
- **NET LB** indicates a manual network loopback when On or a network-activated network loopback when blinking.
- **EQ LB** indicates a manual equipment loopback.

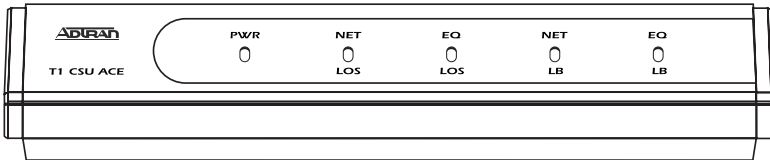

Figure 1-4. T1 CSU ACE LED Alarms

LOOPBACK

The T1 CSU ACE supports three types of loopbacks (LB). With the first two, the unit loops the signal received from the network back to the network and transmits an unframed **all 1s** pattern to the CPE. The signal received from the CPE is ignored. The **NET LB** LED will be illuminated when either form of network loopback is in progress (See Figure 1-5).

The first type of loopback, **Manual Network Loopback**, is initiated by switching on the **NET LB** switch on the back of the unit. The **NET LB** LED will turn **On** and the loopback will continue until it is switched off. See Figure 1-5.

The second type of loopback, **Network LB**, is activated by sending the unit a **1-in-5** pattern (10000) from the network side for five seconds. The **NET LB** LED will **blink** until it is cleared by sending a **1-in-3** pattern (100) for five seconds. The patterns may be **Unframed** or **Framed** (SF or ESF).

The third type of loopback, **Manual Equipment Loopback**, is initiated by the **Equip LB** switch on the back of the unit. It will continue until **Equip LB** is switched off. With the **Equip LB**, the unit loops the signal received from the CPE equipment back to the CPE equipment, and transmits an unframed **all 1s** pattern to the network. The signal received from the network is ignored. The **EQ LB** LED will **illuminate** when the loopback is in progress. See Figure 1-5.

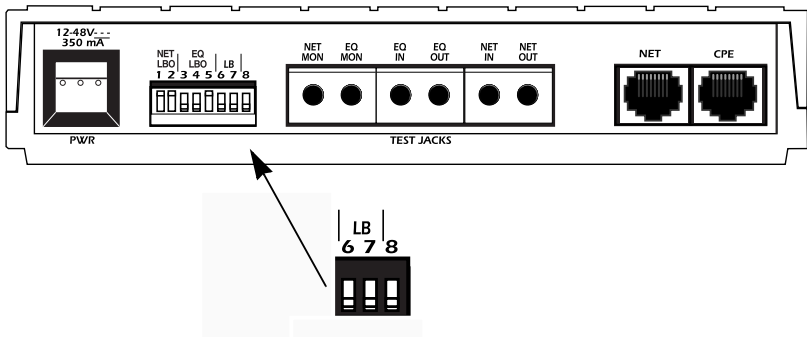

Figure 1-5. T1 CSU ACE Loopback Switch and LED

LINE BUILD OUT

The first five positions of the switch on the back of T1 CSU ACE selects **Line Build Out (LBO)**. See Figure 1-6. Separate LBOs set the transmit levels for the network and CPE sides of the T1 CSU ACE. The receivers on both sides of the CSU ACE contain **Automatic Line Build Out (ALBO)** circuitry to compensate for loss.

On the **Network side**, the amount of attenuation in decibels (dB) specified by the carrier can be selected as shown in Table 2-1 on page 2-1.

On the **CPE side**, the amount of attenuation is determined by the maximum length of cable between the T1 CSU ACE and the CPE, as shown in Table 2-2 on page 2-1.

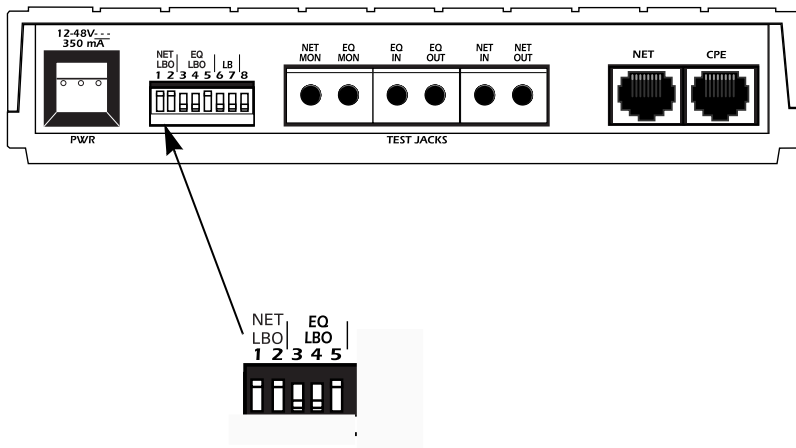

Figure 1-6. Line Build Out Switch

SETTING THE LBO SWITCH POSITIONS

Network and customer LBO Switch position settings are defined in Table 2-1 and Table 2-2.

Table 2-1. Network LBO Switch Position Settings

POSITION 1	POSITION 2	ATTENUATION (dB)
On	On	0
On	Off	7.5
Off	On	15
Off	Off	22.5

Table 2-2. Customer LBO Switch Position Settings

POSITION 3	POSITION 4	POSITION 5	CABLE LENGTH (feet)
Off	Off	On	0-133
On	On	Off	134-265
Off	On	Off	266-399
On	Off	Off	400-533
Off	Off	Off	534-655

POWERING THE UNIT

The unit may be powered by using the supplied NEC Class 2, 12V wall mount power supply. It may also be locally powered by using the power cable supplied and the customer's own 12 to 48-volt power supply.

See Figure 2-1 on page 2-3 for an illustration of cable installation. Once power has been applied to the unit, the **POWER LED** will be illuminated.

The unit can be powered by either of the following methods:

Method 1

- | |
|--|
| <ul style="list-style-type: none">• Use the included NEC Class 2, 12V at 400 mA wall mount power supply. |
|--|

<i>Note: The wall outlet shall be near the equipment and readily accessible.</i>
--

OR

Method 2

- | |
|--|
| <ul style="list-style-type: none">• Connect to a reliably-grounded 12-48 Vdc source which is electrically isolated from the AC source. |
|--|

<i>Note: The branch circuit overcurrent protection shall be a fuse or circuit breaker rated 48 V, minimum to 10A, maximum.</i>
--

<i>A readily accessible disconnect device that is suitably approved and rated, shall be incorporated in the field wiring.</i>

<i>The unit shall be installed in accordance with the requirements of NEC NFPA 70, where applicable.</i>
--

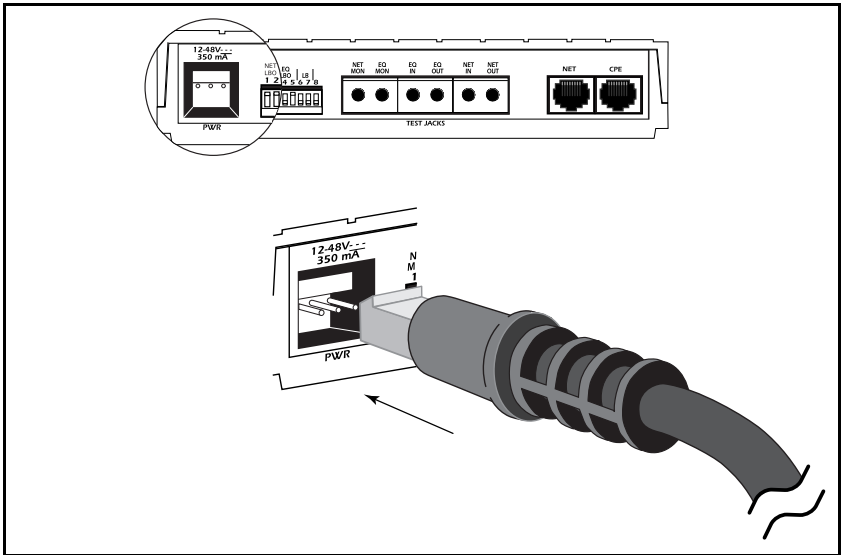

Figure 2-1. Power Connection



With the T1 CSU face up, plug in the cable with the plug oriented as shown above.

CONNECTING TO THE NETWORK AND CPE

Two 8-pin modular connectors are located on the back of the T1 CSU ACE (see Figure 2-1 on page 2-3). **Net** connects the unit to the network via the network cable. The connector marked **CPE** connects the cable from the customer equipment to the T1 CSU ACE.

Notify the carrier before connecting the T1 CSU ACE to the carrier network. Connect the T1 CSU ACE to the network demarcation before connecting to the **CPE**. Connector pin assignments for the Net RJ48C are listed in Table 2-3. Connector pin assignments for the CPE 8-Pin modular jack are listed in Table 2-4.

Table 2-3. Network RJ48C Connector Pin Assignments

PIN	NET
1	R1 (Receive from Network)
2	T1 (Receive from Network)
3	Not Used
4	R (Transmit to Network)
5	T (Transmit to Network)
6	Not Used
7	Not Used
8	Not Used

Table 2-4. CPE Connector Pin Assignments

PIN	CPE
1	R (Transmit to CPE)
2	T (Transmit to CPE)
3	Not Used
4	R1 (Receive from CPE)
5	T1 (Receive from CPE)
6	Not Used
7	Not Used
8	Not Used

TEST AND MONITOR ACCESS

The six Bantam jacks located on the back of the T1 CSU ACE provide test and monitor access for the network and equipment side of the T1 CSU ACE. The diagram on the face of the unit shows each jack's function, as seen in Figure 2-2.

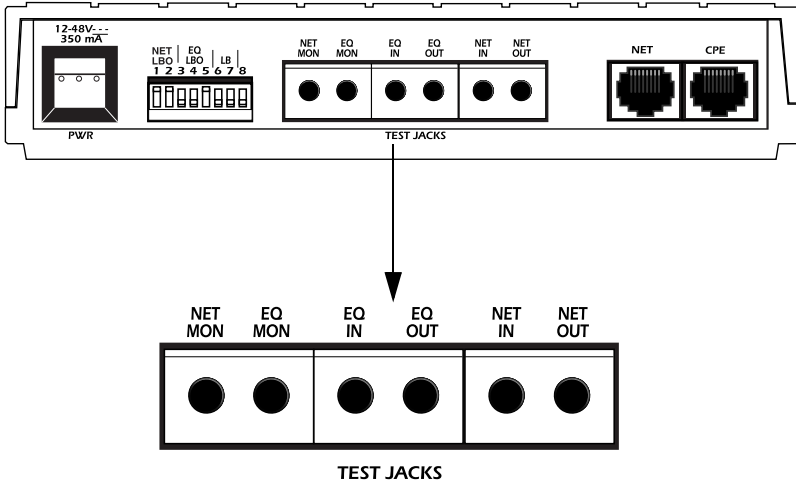

Figure 2-2. T1 CSU ACE Bantam Jacks

Monitor Jacks

The first two jacks are **monitor jacks** used for monitoring the circuit while in service. **NET MON** monitors the signal received from the network. **EQ MON** monitors the signal received from the CPE.



*The test set's input impedance must be set for **DSX-MON** when connected to the monitor jacks.*

Break-and-Test Jacks

The other four jacks are **break-and-test** jacks used for out-of-service testing. These jacks bypass the connections of the modular jacks. **NET IN** and **NET OUT** are used to simulate the network input and output of the T1 CSU ACE. To test the CPE, a T1 Bit Error Rate Test (BERT) test set can be used to simulate the network. **EQ IN** and **EQ OUT** can be used to simulate the CPE with a BERT test set, allowing the network to be tested. The T1 CSU ACE on the other end of the circuit can be looped back to test only the network. Most BERT test sets have the ability to send LB enable and LB clear codes.



NOTE

*The test set's input impedance must be set for **TERM** when connected to the break-and-test jacks.*

WALL MOUNTING

The T1 CSU ACE includes a plate that can be screwed to the back of the unit for wall mounting. See Figure 2-3.

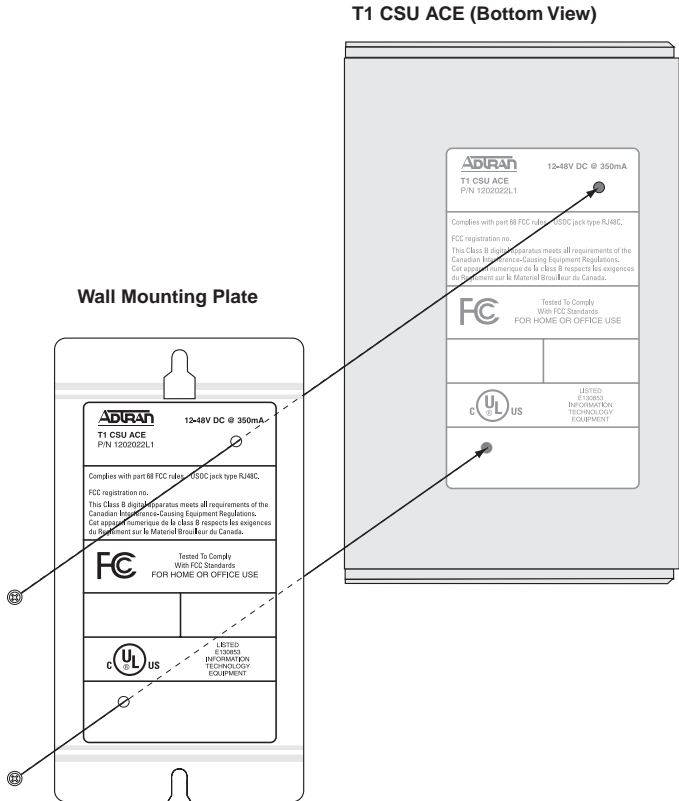

Figure 2-3. Wall Mounting

Chapter 3 Troubleshooting and Maintenance

Troubleshooting guidelines and maintenance information are provided in this chapter.

TROUBLESHOOTING

Power

Condition: PWR LED is not illuminated.

1. If locally powered, verify the power cable installation.
2. If the 12-volt wall-mount power supply is used, check the supply's cable and the circuit breaker for the 120 V receptacle the supply is plugged into.

Network LOS

Condition: NET LOS LED is illuminated.

1. Verify that the cable from the network demarcation is in **NET** modular jack on the bottom/end of the T1 CSU ACE.
2. If all connections seem intact, the far end CSU ACE can be looped back (using a BERT test set to send the LB code, or using **MANUAL LB** at the other end) to isolate the problem to the far end customer premises or the network.
3. If the problem persists after the LB has been activated, the problem appears to be within the network or the far end CSU ACE. In this case, notify the carrier.
4. If the problem disappears after loop-up, then the cause must be at the far end customer premises.

Equipment LOS

Condition: EQ LOS LED is illuminated.

1. Verify that the cable from the CPE is in the **CPE** modular jack on the bottom/end of the CSU ACE.
2. If all connections seem intact, use a BERT test set in the **NET IN** and **NET OUT** jacks to test the CPE.

Power On - Self Check Failure

Condition: NET LOS, EQ LOS, NET LB, and EQ LB all flash in unison, continuously.

- The unit has failed its' internal self check. Return the unit to the ADTRAN Customer and Product Service (CAPS) Department as instructed in the Product Support page on the back page of this manual.

EPROM Checksum Failure

Condition: NET LOS and EQ LOS Flash alternately with NET LB and EQ LB for the first 10 seconds after power up.

- The unit's EPROM has a bad checksum. Return the unit to the ADTRAN CAPS Department as instructed in the Product Support page on the back page of this manual.

MAINTENANCE

The T1 CSU ACE requires no routine maintenance. No repairs should be performed by the customer. Repair services can be obtained by returning the unit to the ADTRAN Customer and Product Service (CAPS) department as instructed in the Product Support page on the back page of this manual.

NETWORK AND CUSTOMER INTERFACE

Line

4-Wire (T, R, T1, and R1).

Data Rate

1.544 Mbps +/-50 bps.

Signal Format

Bipolar with B8ZS transparency.

Output Amplitude

6 Volts, peak-to-peak nominal.

Network Connector Type

8-pin modular (RJ48C).

Customer Interface Connector Type

8-pin modular jack.

LED INDICATORS

Power

Power is On.

Net LOS

Loss of Signal from network.

Equip LOS

Loss of Signal from CPE.

NET LB

Network or manual loopback.

EQ LB

Manual Loopback.

POWER

Local Power

35 mA typ. at 48 volts.

90 mA typ. at 12 volts.

ENVIRONMENTAL

Temperature

Operating 0°C to 50°C.

Storage -20°C to 70°C.

Relative Humidity

Up to 95% (non-condensing).

Index

A

alarms, using to troubleshoot 1-4
Automatic Line Build Out 1-6

B

Break-and-Test Jacks 2-6

C

Canadian Emissions Requirements iv
Canadian Equipment Limitations v
Connecting to the network and CPE 2-4
Customer Interface Connector Type 4-1
Customer LBO Switch Positions 2-1

D

Data Rate 4-1

E

Environmental, specifications 4-2
EPROM Checksum Failure 3-2
EQ LB, alarm 1-4
EQ LB, LED indicator 4-2
EQ LOS 1-4
EQ LOS, alarm 1-4
EQ MON 2-5
Equip LB 1-5
Equip LOS, LED indicator 4-1
Equipment LOS, problems 3-2

F

FCC Radio Frequency Interference Statement iv
FCC regulations iii

I

installation 2-1

L

LBO Switch positions 2-1
LBO, line buildout 1-6

LED Indicators, specifications 4-1
limited product warranty ix
Line Build Out 1-6
Line, 4-wire 4-1
Local Power 4-2
loopback
 manual, network, equip 1-5

M

Maintenance 3-2
Manual Loopback 1-5
Monitor Jacks 2-5

N

NET LB 1-5
NET LB, alarm 1-4
NET LB, LED indicator 4-1
NET LOS, alarm 1-4
Net LOS, LED indicator 4-1
NET MON 2-5
Network and Customer Interface, specifications 4-1
Network Connector Type 4-1
Network LBO Switch Positions 2-1
Network Loopback 1-5
Network LOS, problems 3-1

O

Output Amplitude 4-1

P

POWER LED, alarm 1-4
Power On - Self Check Failure 3-2
power options 1-3
Power, LED indicator 4-1
Power, problems 3-1
Power, specifications 4-2
Powering the Unit 2-2

R

return material authorization (RMA) vi

S

safety instructions vi
Setting the LBO switch positions 2-1
Signal Format 4-1
Specifications 4-1

T

T1 CSU ACE, overview 1-1
Temperature, storage and operation 4-2

test and monitor access 2-4
Troubleshooting 3-1

U

Unit overview 1-1

W

Wall Mounting the unit, how to 2-7
warranty and customer service vi

Product Support Information

Presales Inquiries and Applications Support

Please contact your local distributor, ADTRAN Applications Engineering, or ADTRAN Sales:

Applications Engineering (800) 615-1176

Sales (800) 827-0807

Post-Sale Support

Please contact your local distributor first. If your local distributor cannot help, please contact ADTRAN Technical Support and have the unit serial number available.

Technical Support (888) 4ADTRAN

Repair and Return

If ADTRAN Technical Support determines that a repair is needed, Technical Support will coordinate with the Customer and Product Service (CAPS) department to issue an RMA number. For information regarding equipment currently in house or possible fees associated with repair, contact CaPS directly at the following number:

CAPS Department (256) 963-8722

Identify the RMA number clearly on the package (below address), and return to the following address:

ADTRAN, Inc.
CAPS Department
6767 Old Madison Pike
Progress Center
Building #6, Suite 690
Huntsville, AL 35807

RMA # _____

