



9 Series Controlled Humidity Heated Holding & Proofing Cabinets

USER MANUAL



InterMetro Industries Corporation
Wilkes-Barre, PA 18705
570-825-2741 www.metro.com



METRO[®]

CONTROLLED HUMIDITY CABINET BASIC OPERATING GUIDELINES

1. With the POWER switch OFF, plug the supply cord into a grounded 20 amp 120VAC receptacle. (refer to the cabinet data plate for ampere rating).
2. Fill the water reservoir in the floor of the cabinet with clean warm water. The capacity of the reservoir is about 4½ US. Gallons (17 liters). The water level should be no higher than ½ inch (13mm) below the bottom of the water reservoir cover
3. Ensure that the water reservoir cover is installed (refer to the cabinet operating instructions). This is required for the cabinet to function properly.
4. Set the POWER switch to the ON position.
5. The cabinet will initially display current temperature and humidity set points and then show the actual cabinet temperature and humidity.
6. The temperature and humidity displays will continue to blink until the temperature set point is reached.
7. To change temperature or humidity set points, turn a control knob. As a knob is turned, the temperature and humidity display will show the set points, and the "F° and C°" indicator lamps will blink. About 3 seconds after a knob is turned, the display will show the actual cabinet temperature and humidity.
8. Press and release "Recall Set Points" button to see the current cabinet temperature and humidity set points.
9. To see the current alarm set point, press and release "Low Temp Alarm" button. To change the alarm set point, press and hold "Low Temp Alarm" button, turn the temperature knob to the desired setting, and release button.
10. To clean cabinet, turn power off, unplug from wall outlet, allow cabinet to cool, wipe with a damp cloth and dry with a towel. Floor of cabinet and water reservoir may be rinsed out with a low pressure hose.
11. Consult the user manual for additional operation and maintenance information.



CAUTION



- UNPLUG CABINET FROM POWER SOURCE, ALLOW CABINET AND WATER TO COOL, BEFORE CLEANING OR SERVICING.
- SOME SURFACES, WATER, AND ESCAPING VAPOR CAN BE HOT ENOUGH TO BURN. USE CAUTION WHEN OPENING DOORS AND WORKING IN AND AROUND THIS CABINET.
- DO NOT SPRAY OR POUR WATER INTO THE CONTROLLER ENCLOSURE. TO CLEAN CABINET, WIPE WITH A DAMP CLOTH AND DRY WITH A TOWEL. FLOOR OF CABINET AND WATER RESERVOIR MAY BE HOSED OUT AT LOW PRESSURE.
- KEEP THE CABINET CLEAN. ACCUMULATION OF GREASE AND DIRT MAY IGNITE.

TABLE OF CONTENTS

SECTION	PAGE
I. Quick Start Guide	(cover)
II. Basic Operating Guidelines.....	Inside Front Cover
III. Safety Instructions.....	1
IV. Identifying Your Cabinet	2
V. Installation & Set-up	3
VI. Product Features	7
VII. Operating Instructions.....	8
VIII. Care & Maintenance	10
IX. Basic Troubleshooting	11
X. Service & Replacement Parts	13
XI. Warranty.....	Inside Back

SAFETY INFORMATION

WARNING: Follow all food safety guidelines. Pre-heat the cabinet to the desired temperature before placing cooked, hot food into the cabinet. This is not a re-thermalizing cabinet. Food must be at the appropriate temperature before being placed into this cabinet. Use a food probe to check internal food temperature — the cabinet temperature is not necessarily the internal food temperature.

WARNING: Only factory approved service agents should attempt to service, repair or replace electrical components, wiring or power cord.

WARNING: Unplug the cabinet before cleaning or servicing. Do not wash the cabinet with a water jet or high pressure water.

WARNING: This cabinet is only for hot food holding applications.

CAUTION: Do not spray or pour water into the top of the cabinet (control enclosure). To clean the cabinet, wipe with a damp cloth and dry with a towel. Use only cleaning agents approved for stainless steel or aluminum (depending on your cabinet construction). The floor of the cabinet and water reservoir may be hosed out with low pressure water.

CAUTION: Water dripping onto the floor from open doors can be a slip hazard.

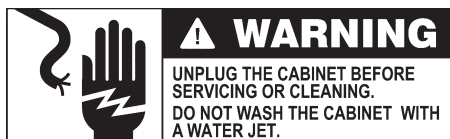

IDENTIFYING YOUR CABINET

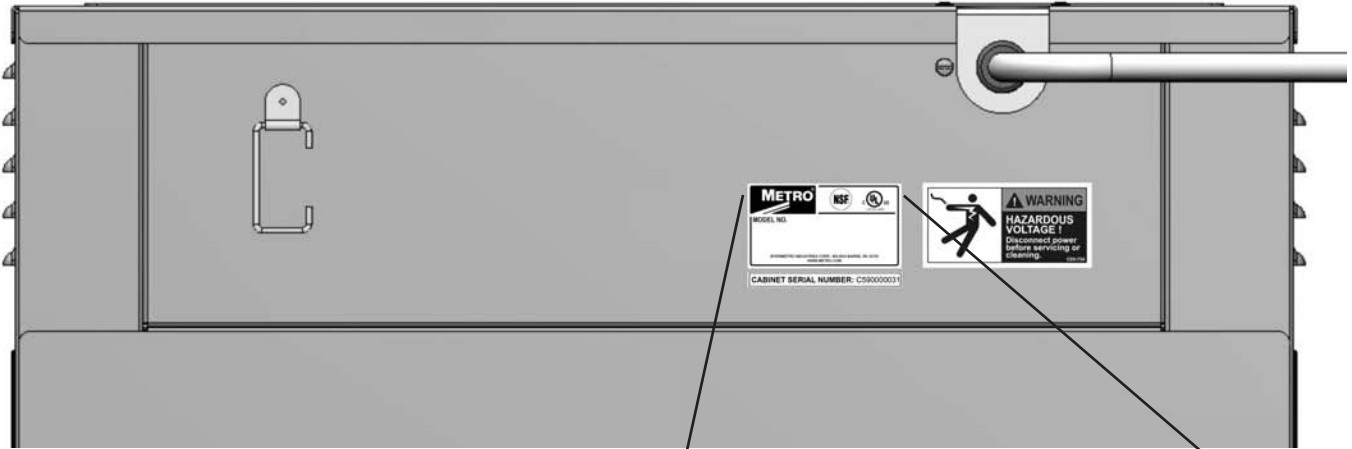

For future reference, note the serial and model number, found on the data plate of the cabinet, here.

Serial number _____

Model number _____

Date the cabinet was put into service _____

Fill out and return the warranty card located at the back of this manual.

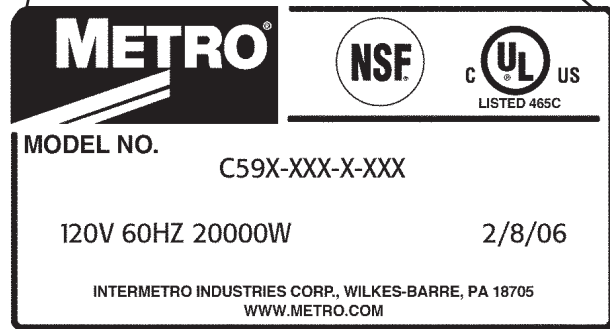

CABINET SERIAL NUMBER: C590000031

PART NUMBERING

C5 9 9 - S FS - L P FS A

CABINET NAME _____

CABINET TYPE _____

9 = 9 SERIES
(CONTROLLED HUMIDITY)

CABINET SIZE (HEIGHT) _____

9 = FULL
7 = 3/4
5 = 1/2
3 = UNDER COUNTER

MATERIAL _____

S = STAINLESS
N = ALUMINUM

A = ACCESSORIES (IF APPLICABLE)

**REAR DOOR(S)
(PASS-THRU)**

BLANK = NON-PASS THRU
FS = FULL SOLID
DS = DUTCH SOLID
FC = FULL CLEAR
DC = DUTCH CLEAR

CABINET CONSTRUCTION

BLANK = NON-PASS THRU
P = PASS-THRU, DOORS
(FRONT & REAR)

SLIDES

L = LIP LOAD (FIXED)
U = UNIVERSAL (ADJUSTABLE)

FRONT DOOR(S)

FS = FULL SOLID
DS = DUTCH SOLID
FC = FULL CLEAR
DC = DUTCH CLEAR

INSTALLATION AND SET-UP

1. Check for Shipping Damage: Check the packaging and cabinet for shipping damage before and after unloading the unit, and after removing all the packaging.
2. The receiver of this product is responsible for filing freight damage claims. This equipment must be opened immediately for inspection. All visible damage must be reported to the freight company within 48 hours and must be noted on freight bill at the time of delivery.
3. Concealed damage is your responsibility — you must advise the carrier of any loss or damage within 15 days after receipt of the cabinet. If there is damage, retain the original packaging for inspectors.
4. After unpacking the cabinet, remove all tape and packing material from the inside as well as outside of the unit.
5. Any protective covers (plastic or paper sheet) on the sheet metal or clear door(s), if applicable, must also be removed before turning the cabinet on.

WARNING: Only factory approved service agents should attempt to service, repair or replace electrical components, wiring or the power cord.

6. The power cord can be installed to exit the back of the cabinet for wall outlets or out the top of the cabinet for ceiling power drops. To change the position of the power cord, first make sure the cabinet power switch is off and the power cord is unplugged from any electrical outlet. Remove the (7) screws holding the cabinet top in place. Lift the rear portion of the cabinet top and slide it away from under the front control bezel, removing it from the cabinet. Remove the (2) screws on the rear of the cabinet that hold the cord bracket in place. Rotate the power cord bracket 90° to the desired position and reattach it with the (2) screws to the back of the cabinet. Make sure the green ground wire connection and the wire nuts on the black and white wires are not loosened. Do not alter the wiring of the power cord to the cabinet. Replace the cabinet top and the (7) screws holding it in place.



7. Plug the power cord into a grounded outlet with a minimum of 20 amp electrical service. The required electrical service is 120 VAC, 60 cycle, single phase. Make sure all applicable local electrical codes are met.

Wrong
15 Amp Outlet



Correct
20 Amp Outlet

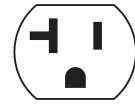

8. The factory setting for temperature is Fahrenheit. To change the temperature display from Fahrenheit to Celsius a jumper needs to be changed on the back of the controller circuit board. Turn the cabinet off, unplug the cabinet from the electrical supply and remove the top of the cabinet (refer to step #6). See the control wiring diagram below for the location of jumper JP5. For Fahrenheit control, the jumper is on the lower two pins. For Centigrade control, move the jumper from the lower two pins to the upper two pins. After changing the jumper, replace the top, plug the cabinet in, turn the cabinet on and **adjust the temperature and low temperature alarm settings for the new units (°C or °F)** of temperature selected.

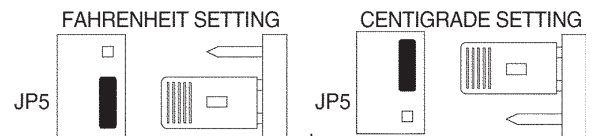

9. Your C5 cabinet is designed to operate next to walls and other kitchen equipment. However, the greater the clearance around the sides and the top of the cabinet, the cooler the electrical components will operate. This may result in a longer life expectancy for the electrical components.

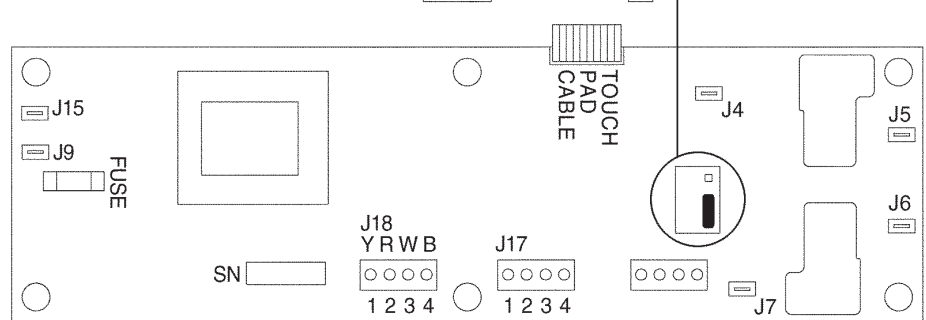

WARNING: Do not allow combustible materials to be stored or accumulate on, under or next to the cabinet. Do not block any ventilation louvers or slots.

INSTALLATION AND SET-UP (continued)

SLIDE INSTALLATION

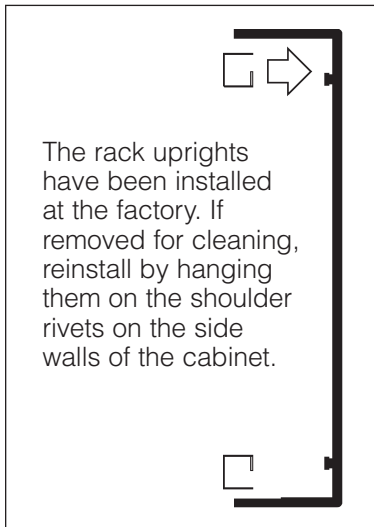

The rack uprights have been installed at the factory. If removed for cleaning, reinstall by hanging them on the shoulder rivets on the side walls of the cabinet.

TOP VIEW

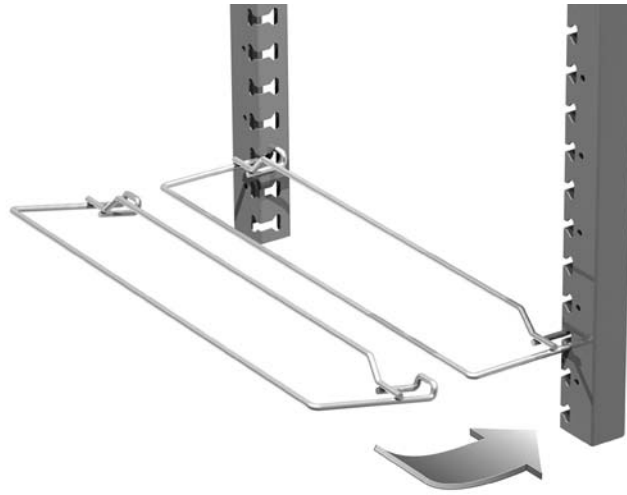

SLIDE POSITION to MAXIMIZE 3" PAN CAPACITY OF UNIVERSAL SLIDES

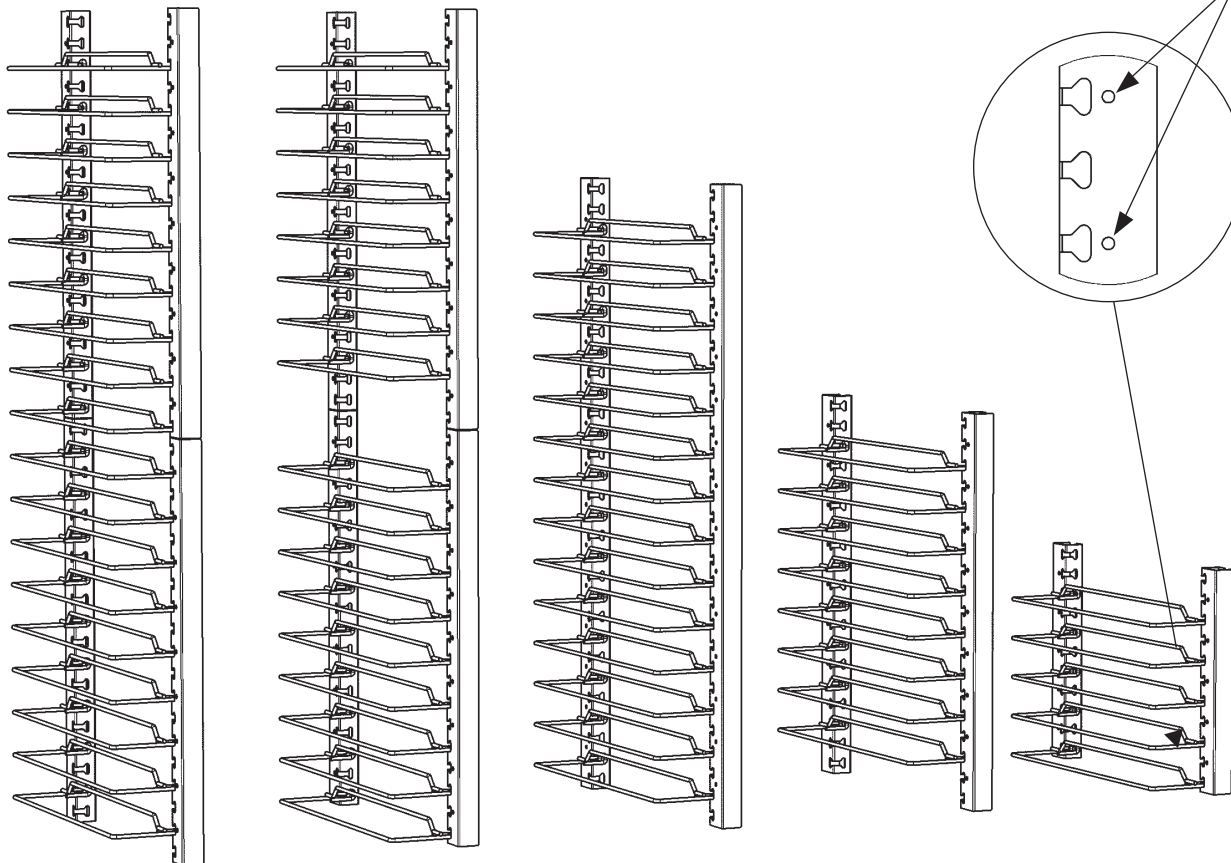

SiteSelect™ features make slide installation easier.

Full Height Single Door
18 Levels
(Position 2nd from Bottom)
Part No. C5-U-9

Full Height Dutch Doors
17 Levels
(Position Bottom)
Part No. C5-U-9

3/4 Height Cabinet
14 Levels
(Position 2nd from Bottom)
Part No. C5-U-7

1/2 Height Cabinet
8 Levels
(Position 3rd from Bottom)
Part No. C5-U-5

Under Counter Cabinet
5 Levels
(Position Bottom)
Part No. C5-U-3

Slides sold in pairs. For additional pair of wire slides, order C5-USLIDECPR.

INSTALLATION AND SET-UP (continued)

CORRECT ORIENTATION OF LIP LOADED SLIDE RACKS

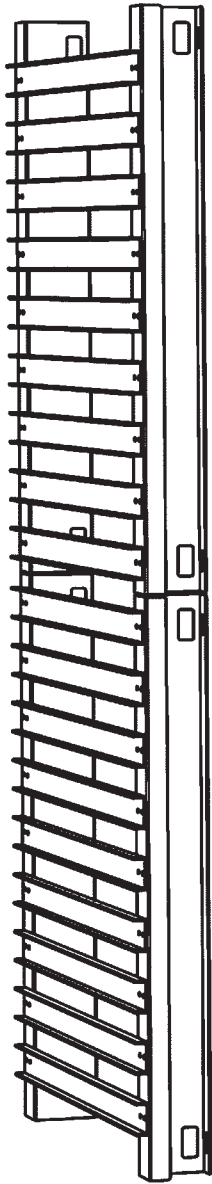

**Full Height
Single Door**
2-piece Construction
Part No. C5-L-9

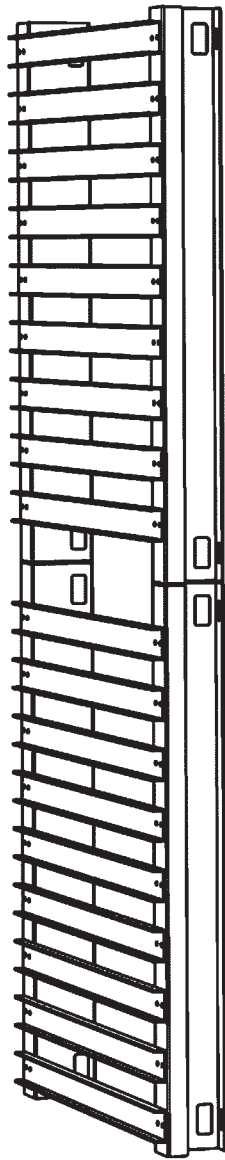

**Full Height
Dutch Doors**
2-piece Construction
Part No. C5-L-9

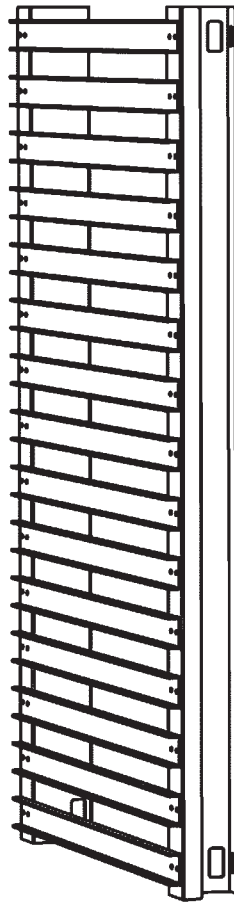

**3/4 Height
Cabinet**
1-piece Construction
Part No. C5-L-7

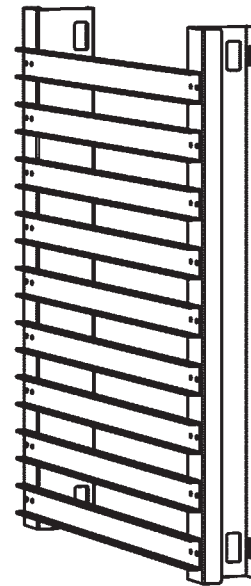

**1/2 Height
Cabinet**
1-piece Construction
Part No. C5-L-5

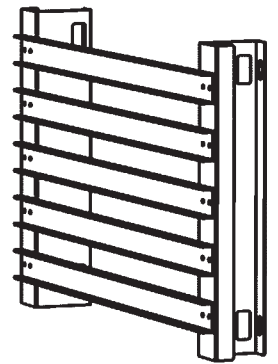

**Under Counter
Cabinet**
1-piece Construction
Part No. C5-L-3

Slides sold in pairs.

REVERSING THE DOORS

⚠ WARNING • TIP HAZARD

Tip Hazard: On Pass-Thru cabinets that include any clear doors, when field reversing, the front and back doors must be hinged from opposite sides of the cabinet. See illustration below.

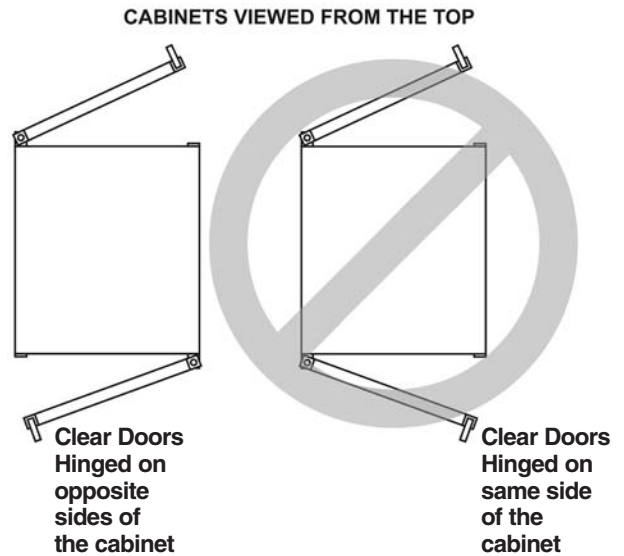
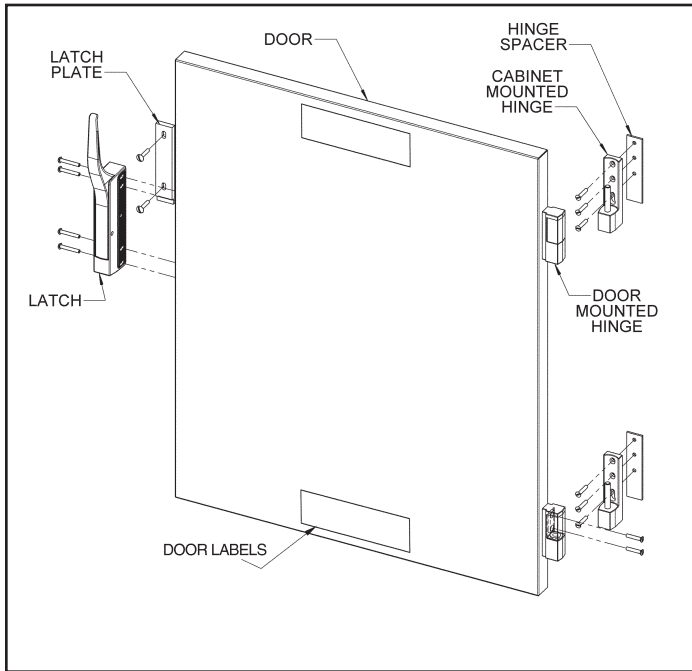

After reversing the door hinging direction, labels are now upside down. You may contact InterMetro for a new set of labels, part number RPC5-DRLBL, at no charge, to be placed in the proper orientation.

C5 doors are normally hinged on the right hand side at the factory. If the cabinet has been in operation, allow the door to cool before reversing the door hinging direction. Note: When finished, all holes will have screws in them and there will be no exposed holes left in the cabinet.

1. If the cabinet has Dutch Doors, note which is the top and which is the bottom door. Open the door, lift it off the cabinet hinges and set it aside noting which is the top and bottom of the door.
2. On the cabinet, remove the latch strike plate and hinges and install them on the other side of the cabinet. On the door, remove the hinge covers to access the mounting screws. Remove the hinges.
3. Rotate the door so the previous bottom is now the top and install the hinges. On Dutch Doors, do not remove the handles, the top door becomes the bottom and the bottom door the top. On single door units, rotate the handles 180° and reinstall.
4. On the cabinet mounted hinges, lift the white bushing and rotate it 180° and push it down to reseal it on the hinge pin.
5. Install the door onto the cabinet hinges and check to make sure the door latches properly and the gaskets are in compression.

PRODUCT FEATURES

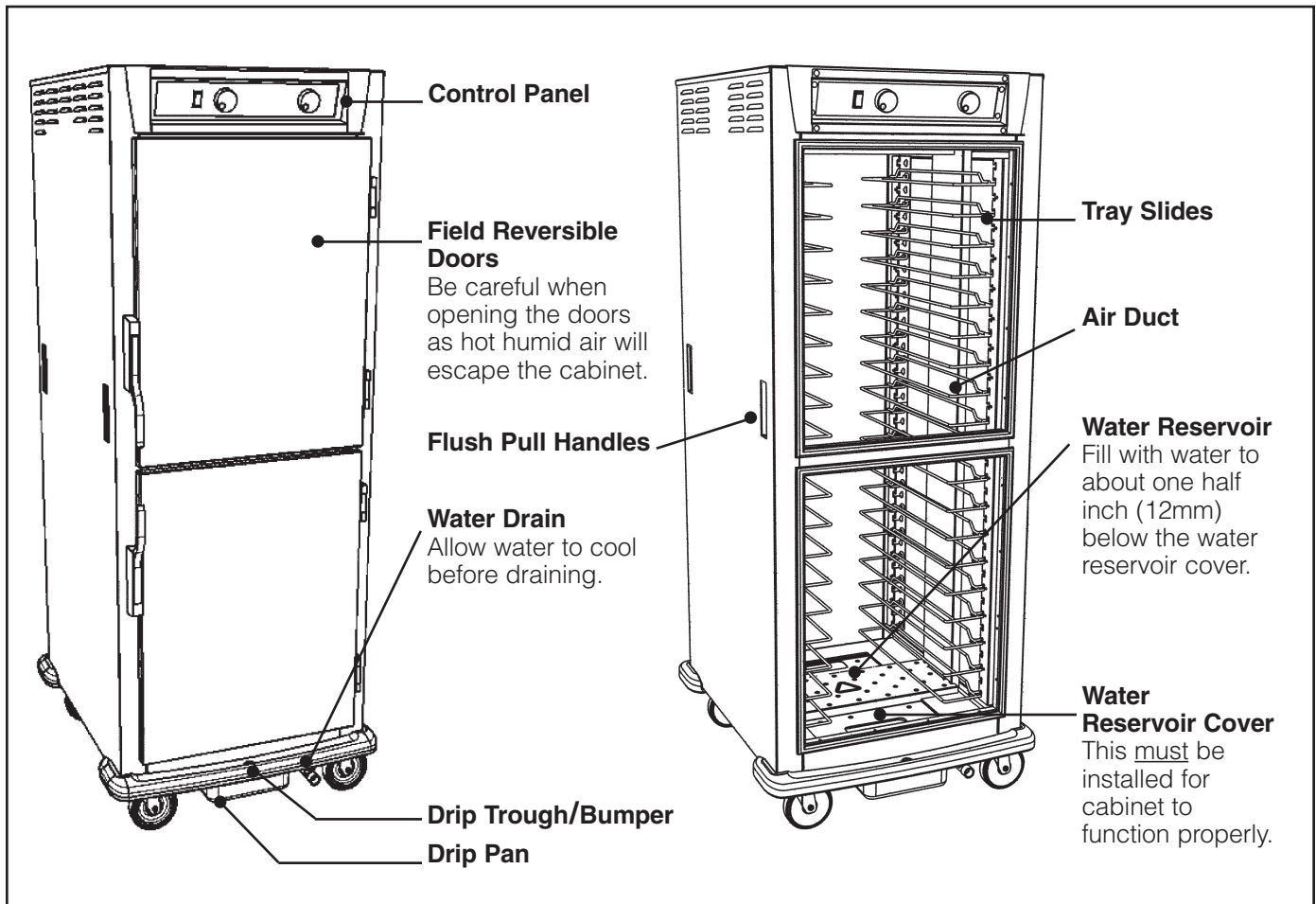

Temperature Control

Controls the temperature in the cabinet. Turn the knob to change the temperature set point. The display shows new set point as the knob is turned.

Humidity Control

Controls the relative humidity in the cabinet. Turn the knob to change the humidity set point. The display shows the new set point as the knob is turned.

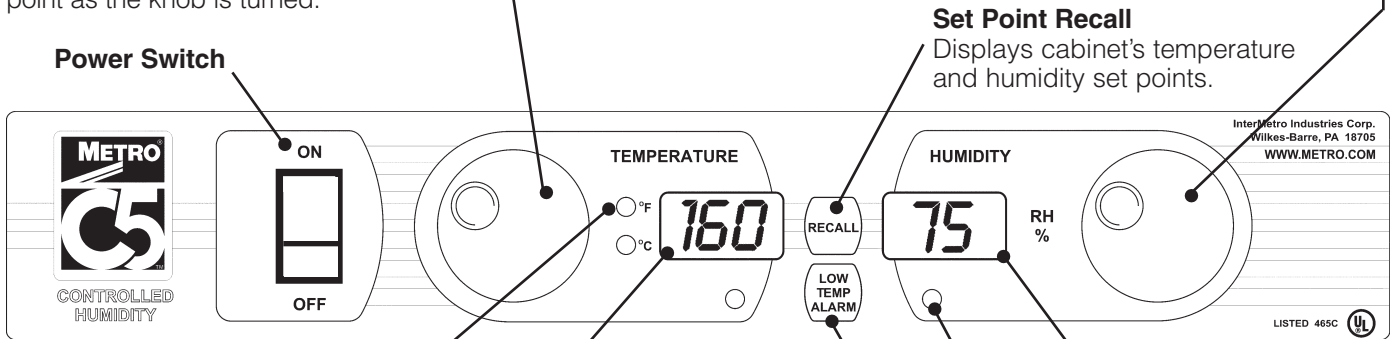

OPERATING INSTRUCTIONS

Power-Up & Pre-Heat

- When the cabinet is switched on, the controller displays “Set Pnt” followed by the current temperature and humidity set points. The temperature and humidity displays will begin to blink, indicating that the cabinet is pre-heating. The displays will stop blinking after the temperature set point is reached.
- **Factory presets are 160°F and 50% relative humidity (RH).**
- Turn “Temperature” and “Humidity” knobs at any time to change the desired settings.
- Press the “Recall” button at any time to display the current temperature and humidity settings.
- If the “Humidity” display flashes “Fill” accompanied by an audible alarm, fill the water reservoir with water.

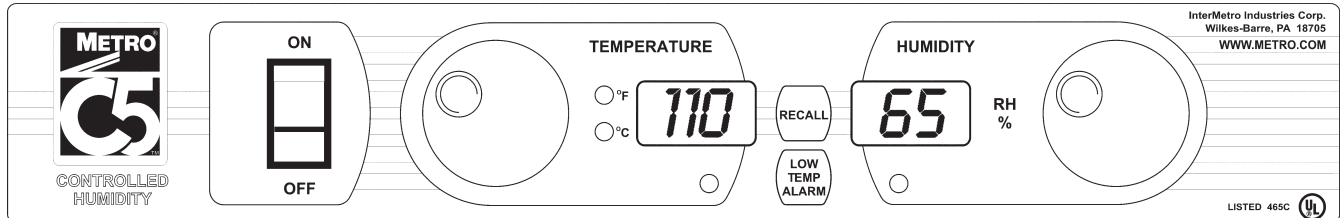

1. Allow the cabinet to pre-heat without food for 30 minutes to an hour. The time required to reach the temperature set point is dependent on the set point, the size of the cabinet, the door type (solid or clear) and the temperature of the room the cabinet is in. **Factory presets are 160°F and 50% RH.**

Warning: Follow all food safety guidelines. Pre-heat the cabinet to the desired temperature before putting cooked, hot food into the cabinet. This is not a re-thermization cabinet. Food must be at the appropriate temperature before being placed into this cabinet.

2. To insure food safety, the C5 cabinet uses Temperature Priority. This feature is designed to minimize the time required to pre-heat a cold cabinet to the desired operating temperature and to recover to the operating temperature after a door has been opened and closed. To do this, during pre-heat and recovery, all the available electrical energy is used to heat the cabinet. (Initially this may cause the temperature to exceed the set point. However, this will rapidly correct itself and equalize to the operating temperature within a few minutes.) The C5 controls will continuously monitor temperature and humidity and energize the heat elements accordingly. Note, as the cabinet pre-heats the air, the humidity level may drop significantly. This is because hotter air can hold more moisture and therefore the relative humidity goes down as the cabinet pre-heats. Once the cabinet operating temperature is reached, the cabinet will then produce humidity as required. The Temperature Priority feature, heat before humidity, ensures the food is held at the desired temperature. Food holding temperature is one of the key elements for safe food holding. By prioritizing temperature, the C5 cabinet promotes food safety when used properly.

Low Temperature Alarm

- The Cabinet is equipped with a low temperature alarm system that will alert you if the cabinet falls below the alarm set point for more than 5 minutes during operation (unless the low temperature alarm has been disabled — see below). The TEMPERATURE display will begin to blink “LO” alternating with the current temperature. An audible alarm will also sound 3 times every 10 seconds (See “Sound On and Off” below for more information on the audio alarm)
- **Factory preset for the low temperature alarm is 140°F.**
- To check the existing low temperature alarm set point, press and release the LOW TEMP ALARM button.
- To change the low temperature alarm set point, press and hold the LOW TEMP ALARM button while turning the TEMPERATURE knob.
- If the cabinet’s temperature set point is set below the low temperature alarm set point, the alarm is disabled.
- The low temperature alarm is also disabled during pre-heat.

Sound On and Off

Press LOW TEMP ALARM and RECALL and hold for 5 seconds to toggle sound off and on. Display will show “SND OFF” or “SND ON”

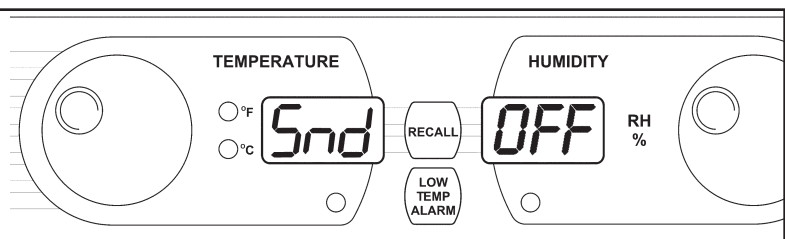

- Your C5 9 Series cabinet is capable of creating high levels of humidity at all operating temperatures. As you operate the cabinet and open and close the door(s), condensation will form on the inside surfaces of the cabinet. Some dripping of water may occur to the outside of the cabinet particularly at the door seals. A drip trough is part of the bumper and will direct most of this water to a removable water pan under the bumper. Water may also drip off opened doors onto the floor.

Caution: Water dripping onto the floor from open doors can be a slip hazard.

Warning: Some surfaces, water and escaping vapor can be hot enough to burn. Use caution when opening doors and working in and around this cabinet.

- The cabinet controls will “remember” their settings when the cabinet is turned off. Therefore, when the unit is turned on the settings will be the same as they were during the previous use.



- A red indicator light below each digital display indicates when the temperature or humidity heater element is energized. As the control settings are adjusted, it may take a few moments for the status of the indicator lights to reflect the new control settings and cabinet conditions depending on when in the control cycle the settings are changed.

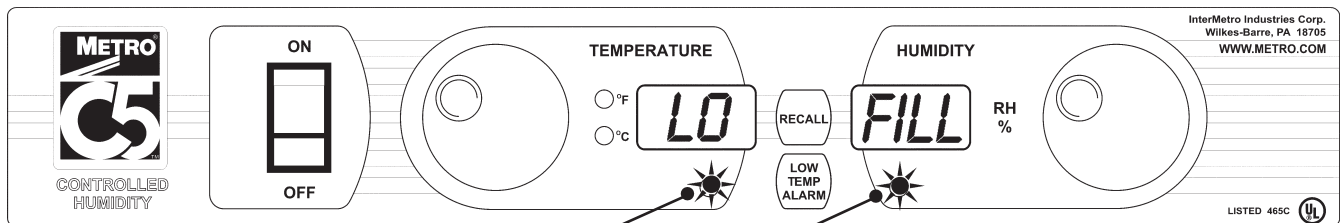

Element Indicators

- If humidity is required, fill the water reservoir in the bottom of the cabinet to about 1/2" (13mm) below the bottom of the water reservoir cover. Potable (suitable for drinking) water should be used. Water can be poured through the rectangular hole in the water reservoir cover. If the cover is removed, replace it before using the cabinet. A water sensor detects a low water condition and will prevent the water reservoir element from being energized. The reservoir needs refilling when there is about 1" (25mm) of water left in the reservoir. At this point, the display will blink “Fill,” and an audible alarm will sound every 10 seconds, and **the water reservoir element will not heat until the water reservoir is filled.** If humidity is not required, empty the water reservoir and turn the humidity control knob counterclockwise until the display reads “Off.” This will prevent the display from blinking “Fill.”

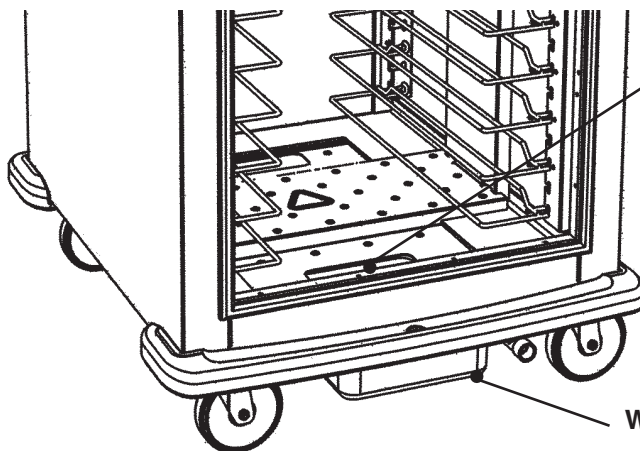

Water Reservoir

Fill with water to one half inch below the water reservoir cover.



Water Reservoir Drain Valve

- To remove the water from the water reservoir, allow the water to cool, open the drain valve under the right end of the drip trough and allow the water to drain. Any remaining water in the bottom of the reservoir can be removed with a clean towel.

Note: When turning the cabinet off at the end of the work day, it is recommended to leave the door(s) open to prevent heat and condensation build up within the cabinet.

Note: If the cabinet is not going to be used for an extended period of time, all water should be removed from the water reservoir and the cabinet completely cleaned and dried out.

CARE & MAINTENANCE

Cleaning The Cabinet

Warning: Unplug the cabinet before cleaning or servicing. Do not wash the cabinet with a water jet or high pressure water.

Caution: Do not spray or pour water into the control enclosure. To clean the cabinet, wipe with a damp cloth and dry with a towel. Use only cleaning agents approved for stainless steel or aluminum (depending on your cabinet construction).

Caution: Do not use cleaners with chlorides or phosphates as they may cause damage to stainless steel. Do not use strong alkalis on aluminum as they may discolor it.

1. Use cleaners in the proper concentrations. Follow the manufacturer's directions for the cleaning product used. The floor of the cabinet and water reservoir may be hosed out with low pressure water. After using any cleaning products, thoroughly rinse all surfaces to remove all residue.
2. Use a damp cloth or sponge. Mild soap suitable for stainless steel and aluminum is acceptable. Dry with a clean towel. Wipe up spills as soon as possible and regularly clean the cabinet to avoid staining and difficult to clean conditions.

If a control knob needs to be removed for cleaning, use a $\frac{5}{64}$ " Allen key to loosen the set screw on the control knob. Remove the knob, clean the control face and/or knob and replace the knob and tighten the set screw.

Cleaning and De-scaling Instructions for the Water Reservoir:

1. Use only potable water (water suitable for drinking) in the cabinet. The reservoir is equipped with a heater, which heats the water to create humidity and a water level sensor. As water evaporates from the reservoir, any minerals and chemicals present in the water are left behind in the remaining water. Given enough time, these minerals can build up on the reservoir, heater and sensor causing corrosion and a decrease in performance. Using distilled water or conditioned water will help prevent scale build up. **If distilled water is used, you may need to add baking soda to the water for the low water sensor to work properly.** Contact your local water authority for help in determining if a water conditioning system is advised. Adding approximately one tablespoon of white vinegar or lemon juice to the water reservoir will help prevent scale build-up.

Warning: Water inside this cabinet's reservoir is hot during use! Turn the cabinet off, unplug it from the electrical outlet and allow the cabinet and water to cool before draining the water reservoir.

2. **Do not allow scale to build up on the reservoir, heater or sensor.** Dirty water should not be allowed to sit overnight in the cabinet. At the end of each operating day, turn the power off and allow the cabinet and water to cool. Drain the reservoir.

To de-scale the reservoir, heater element and water level sensor you may use a food grade de-scaler suitable for stainless steel. You may already be using a de-scaling product in your kitchen for use in your icemaker, dishwasher or coffee maker equipment. Follow the cleaning instructions on the product label. When finished, thoroughly rinse all cleaning agents off the reservoir, heater and sensor and allow them to dry. At the beginning of the next operating shift, refill the reservoir with potable water.

BASIC TROUBLESHOOTING

Warning: Only factory approved service agents should attempt to service, repair or replace electrical components, wiring or power cord.

1. Controls do not work (no display or indicator lights):

- a. Check that the cabinet is plugged in.
- b. Check that the outlet has power.
- c. Check that the power switch is in the “On” position.
- d. Check the cabinet wiring from the power cord to the power switch and to the controller.
- e. Check that the fuse on the back of the controller is not blown.
- f. Controller is faulty.

2. Controller display all dashes instead of current humidity:

- a. The humidity sensor and controller are not communicating:
 - i. Humidity sensor wires are broken or disconnected from the controller.
 - ii. Humidity sensor filter needs to be cleaned.
 - iii. Humidity sensor needs to be replaced.
 - iv. Controller needs to be replaced.

3. Controller temperature display does not change (displays a constant value approximately equal to the minimum or maximum of the temperature control range, 70°F (21°C) or 200°F (93°C):

- a. The temperature sensor and controller are not communicating:
 - i. Temperature sensor wires are broken or disconnected from the controller.
 - ii. Controller needs to be replaced.
 - iii. Temperature sensor needs to be replaced.

4. Temperature too hot:

- a. Set point is too high. Turn temperature set point down to the desired temperature.
- b. During initial pre-heat some over temperature may occur but will quickly return to the set point.
- c. If displayed temperature exceeds 220°F (104°C):
 - i. Blower wiring is faulty or disconnected.
 - ii. Blower needs replacing.
 - iii. The thermostat may have failed and the thermal overload device is controlling the temperature. Stop using the cabinet immediately and contact a factory approved service agent.
- d. Water reservoir may be empty but the water reservoir element is on, heating the cabinet. The water sensor probe may need to be cleaned or de-scaled.

5. Temperature too low:

- a. The cabinet may still be in pre-heat or recovering from the a door being opened.
- b. Set point is too low. Turn temperature set point up to the desired temperature.
- c. A door is not closed or sealing properly.
- d. Blower is not circulating air:
 - i. Blower wiring is faulty or disconnected.
 - ii. Blower needs replacing.

6. No heat generated

- a. If the heat indicator light is on but the cabinet does not draw approximately 16 amps:
 - i. Air heater element may be faulty.
 - ii. The wiring to the air heater element may be faulty or disconnected.
 - iii. The controller (air heater relay) may be faulty.
- b. If the heat indicator light does not come on, the controller may be faulty.

7. Humidity is too high:

- a. Set point is too high. Turn humidity set point down to the desired humidity.
- b. The food in the cabinet has enough moisture to drive the cabinet humidity above the set point. This indicates the current set point may dry the food. The humidity set point may need to be adjusted to the displayed humidity level.

BASIC TROUBLESHOOTING (continued)

Warning: Only factory approved service agents should attempt to service, repair or replace electrical components, wiring or power cord.

8. Humidity too low:

- a. Set point is too low. Turn humidity set point up to the desired humidity.
- b. Cabinet may be producing the maximum humidity capable at the current temperature setting and food moisture content. Example: The cabinet might only produce 80% humidity at 200°F (93°C).
- c. A door is not closed or sealing properly.
- d. If the humidity display is blinking “Fill,” the water reservoir needs to be re-filled.
- e. If there is more than 1" (25mm) of water in the water reservoir and the display is blinking “Fill”
 - i. The water in the reservoir is too pure (example — distilled water). Add a tablespoon of baking soda to the water and stir the water.
 - ii. The wiring to the water sensor probe may be faulty or disconnected.
 - iii. The water sensor probe is not pointing vertically down or the plastic bushing is missing from the probe.
 - iv. The water sensor probe may need to be cleaned or de-scaled.
- f. Or see step 9.

9. No humidity generation:

- a. If humidity indicator light is on but the cabinet does not draw approximately 16 amps:
 - i. Water heater element may be faulty.
 - ii. The wiring to the water heater element may be faulty or disconnected.
 - iii. The controller (water heater relay) may be faulty.
- b. If the humidity indicator light does not come on, the controller may be faulty.

10. Displays blink “LO” or “Fill” and Alarm beeps (if “Sound” is on):

- a. If the temperature display alternately blinks the current cabinet temperature and then “LO”, refer to steps 5 and 6.
- b. If the humidity display alternatively blinks the current cabinet humidity level and “Fill”, refer to steps 8d and 8e.

11. Water level is low but display does not flash “Fill.”

- a. Accumulation of dirt or scale needs to be cleaned off of water level sensor.
- b. Controller may be faulty.

12. Cabinet trips GFCI (ground fault circuit interrupter):

A GFCI receptacle protects against “ground faults” whenever an electrical product is plugged into the GFCI outlet by constantly monitoring the electricity for any loss of current. If the current flowing out of the receptacle differs by a small amount from that returning, the GFCI quickly switches off power to that circuit. The GFCI interrupts power extremely fast to minimize the possibility of an electric shock.

- a. The heater elements may absorb some moisture into their casing and insulation during shipment or during long periods of not being used (such as during the summer in a closed school kitchen). Plug the cabinet (without water in the water reservoir) into a non-GFCI outlet, set the temperature to 200°F (93°C) and let it run for 30-60 minutes to dry out any moisture the elements may have absorbed. (If it trips the standard circuit breaker call factory approved service agent.) After drying the elements, plug the cabinet into the GFCI outlet; the cabinet should run without tripping the GFCI.
- b. If the cabinet still trips the GFCI, call a factory approved service agent.

Note: The temperature and humidity controls do not require field calibration.

SERVICE and REPLACEMENT PARTS

C5 9 SERIES REPLACEMENT PARTS

ITEM # Replacement Part No. Description

ELECTRICAL

1	RPC5-9CONTR	CONTROLLER, SENSORS & WIRING
2	RPC13-127	MASTER SWITCH
3	RPC5-KNOB	CONTROLLER KNOB — 1 PIECE
4	RPC11-191	INTAKE COLLAR
5	RPHM20-2103	BLOWER
6	RPC13-093	AIR DUCT ELEMENT
7	RPC13-198	THERMAL CUT-OUT
8	RPC13-099	POWER CORD WITH STR PLUG
	RPC13-217	POWER CORD WITH TWIST LOCK PLUG
	RPQC13-001	POWER CORD WITH RIGHT ANGLE PLUG
9	REC13-098	POWER CORD STRAIN RELIEF
10	RPC13-096	TERMINAL BLOCK
11	RPC07-055	SENSOR CABLE GROMMET
12	RPC5-SCLP	SENSOR CLAMPS & SCREW
13	RPC5-WSNSR	WATER SENSOR & FLGD BUSHING
14	RPC06-885	FLGD BUSHING, WATER SENSOR
15	RPC15-030	BULKHEAD FITTING
16	RPC13-200	WATER RESERVOIR ELEMENT

CABINET BODY

17	RPC06-836B	FULL HEIGHT DOOR GASKET
	RPC06-836C	3/4 HEIGHT DOOR GASKET
	RPC06-836A	1/2 HEIGHT & DUTCH DOOR GASKET
	RPC06-836D	UNDER COUNTER DOOR GASKET
18	RPC5-S9DR	STAINLESS STEEL FULL HEIGHT SOLID DOOR
	RPC5-S7DR	STAINLESS STEEL 3/4 HEIGHT SOLID DOOR
	RPC5-S5DR	STAINLESS STEEL 1/2 HEIGHT & BOT D SOLID DOOR
	RPC5-S9TDDR	STAINLESS STEEL TOP DUTCH SOLID DOOR
	RPC5-S3DR	STAINLESS STEEL UNDER COUNTER SOLID DOOR
	RPC5-N9DR	ALUMINUM FULL HEIGHT SOLID DOOR
	RPC5-N7DR	ALUMINUM 3/4 HEIGHT SOLID DOOR
	RPC5-N5DR	ALUMINUM 1/2 HEIGHT & BOT D SOLID DOOR
	RPC5-N9TDDR	ALUMINUM TOP DUTCH SOLID DOOR
	RPC5-N3DR	ALUMINUM UNDER COUNTER SOLID DOOR
	RPC5-S9CDR	STAINLESS STEEL FULL HEIGHT CLEAR DOOR
	RPC5-S7CDR	STAINLESS STEEL 3/4 HEIGHT CLEAR DOOR
	RPC5-S5CDR	STAINLESS STEEL 1/2 HEIGHT & BOT D CLEAR DOOR
	RPC5-S9CTDDR	STAINLESS STEEL TOP DUTCH CLEAR DOOR

ITEM # Replacement Part No. Description

CABINET BODY (continued)

	RPC5-S3CDR	STAINLESS STEEL UNDER COUNTER CLEAR DOOR
	RPC5-N9CDR	ALUMINUM FULL HEIGHT CLEAR DOOR
	RPC5-N7CDR	ALUMINUM 3/4 HEIGHT CLEAR DOOR
	RPC5-N5CDR	ALUMINUM 1/2 HEIGHT & BOT D CLEAR DOOR
	RPC5-N9CTDDR	ALUMINUM TOP DUTCH CLEAR DOOR
	RPC5-N3CDR	ALUMINUM UNDER COUNTER CLEAR DOOR
19	RPC11-274	DOOR LATCH — 1 PIECE
	RPC14-118A	FLUSH HANDLE DOOR LATCH — 1 PIECE
	RPC14-251	DOOR LATCH WITH TWIST LOCK — 1 PIECE
20	RPC14-042	DOOR HINGE — 1 PIECE
21	RPC5-BMPR	BUMPER/DRIP TROUGH
22	B5DNB	5" BRAKE CASTER
	B3B	3" BRAKE CASTER
23	B5DN	5" SWIVEL CASTER
	B3	3" SWIVEL CASTER
24	RPC5-DRPAN	DRAIN PAN
25	RPC06-872	POCKET HANDLE
26	RPC15-028	RESERVOIR DRAIN VALVE
27	RPC5-WRSVR	WATER RESERVOIR & GASKET
28	RPC06-881A	WATER RESERVOIR GASKET
29	RPSNR-5011	WATER SENSOR RETAINER
*30	C5-L-9	TALL CABINET LIP LOADED SLIDE ASSEMBLY
	C5-L-7	3/4 HEIGHT CABINET LIP LOADED SLIDE ASSEMBLY
	C5-L-5	1/2 HEIGHT CABINET LIP LOADED SLIDE ASSEMBLY
	C5-L-3	UNDER COUNTER CABINET LIP LOADED SLIDE ASSEMBLY
*31	C5-U-9	TALL CABINET UNIVERSAL SLIDE ASSEMBLY (INCLUDES WIRE SLIDES & UPRIGHTS)
	C5-U-7	3/4 HEIGHT CABINET UNIVERSAL SLIDE ASSEMBLY (INCLUDES WIRE SLIDES & UPRIGHTS)
	C5-U-5	1/2 HEIGHT CABINET UNIVERSAL SLIDE ASSEMBLY (INCLUDES WIRE SLIDES & UPRIGHTS)
	C5-U-3	UNDER COUNTER CABINET UNIV. SLIDE ASSEMBLY (INCLUDES WIRE SLIDES & UPRIGHTS)
32	C5-USLIDECPR	UNIVERSAL WIRE SLIDES — 1 PAIR
33	RPQC03-001	EQUIPMENT LEG — QTY. 1
34	RPC5-DRLBL	DOOR LABELS — QTY. 2 (USED WHEN REVERSING DOORS)
35	RPC15-029	DRAIN HOSE ADAPTER

*See pages 4 and 5 for slide identification.
All slides sold as pairs.

SERVICE and REPLACEMENT PARTS (continued)

Replacement Parts Diagram

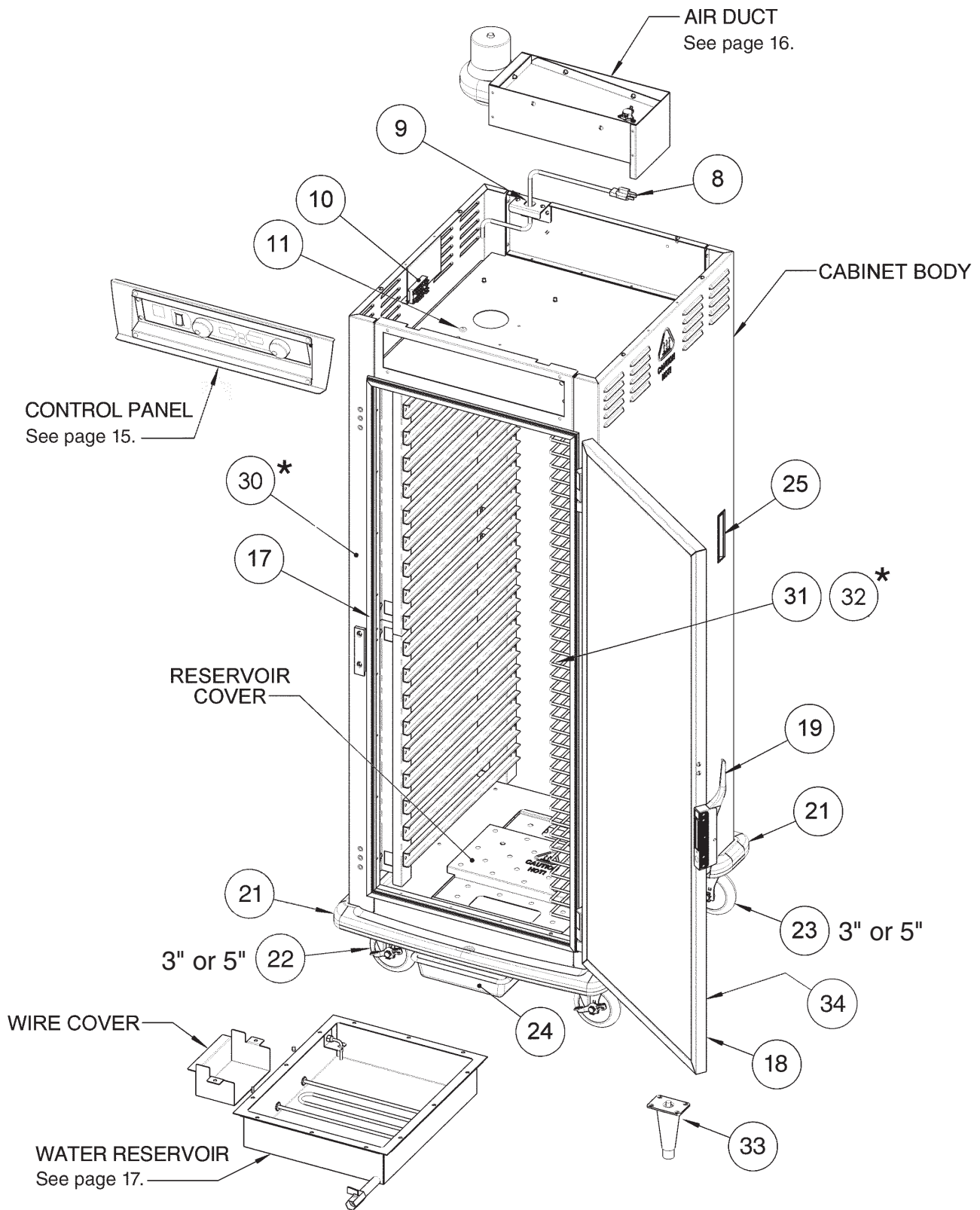

*For slide identification, see pages 4 and 5.

SERVICE and REPLACEMENT PARTS (continued)

Warning: Only factory approved service agents should attempt to service, repair or replace electrical components, wiring or power cord.

To access the controller area, remove the (7) screws holding the cabinet top in place. Lift the rear portion of the cabinet top and slide it away from under the front control bezel, removing it from the cabinet. After servicing, replace the cabinet top and the (7) screws holding it in place.

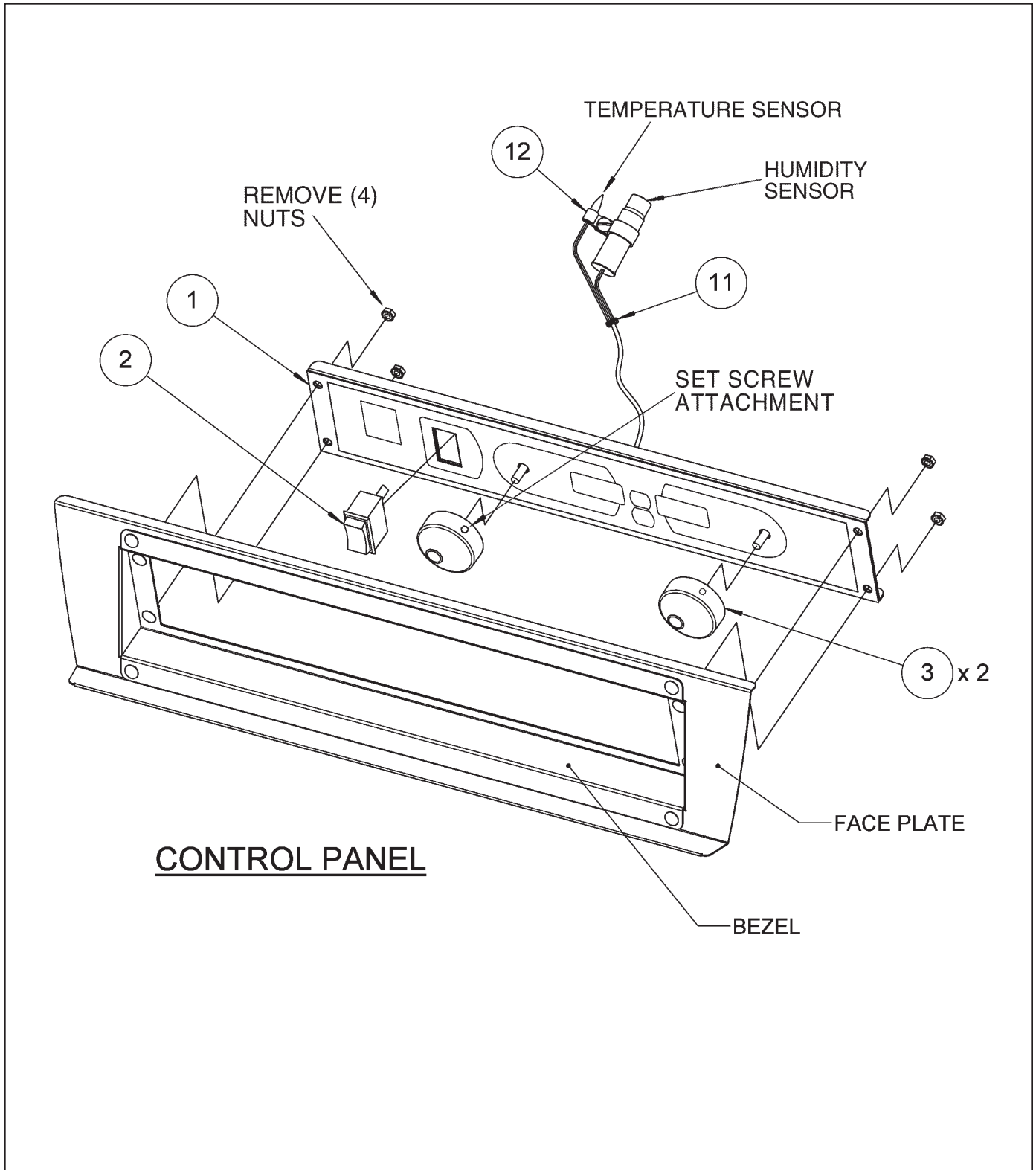

SERVICE and REPLACEMENT PARTS (continued)

Wiring Diagram

Warning: Only factory approved service agents should attempt to service, repair or replace electrical components, wiring or power cord.

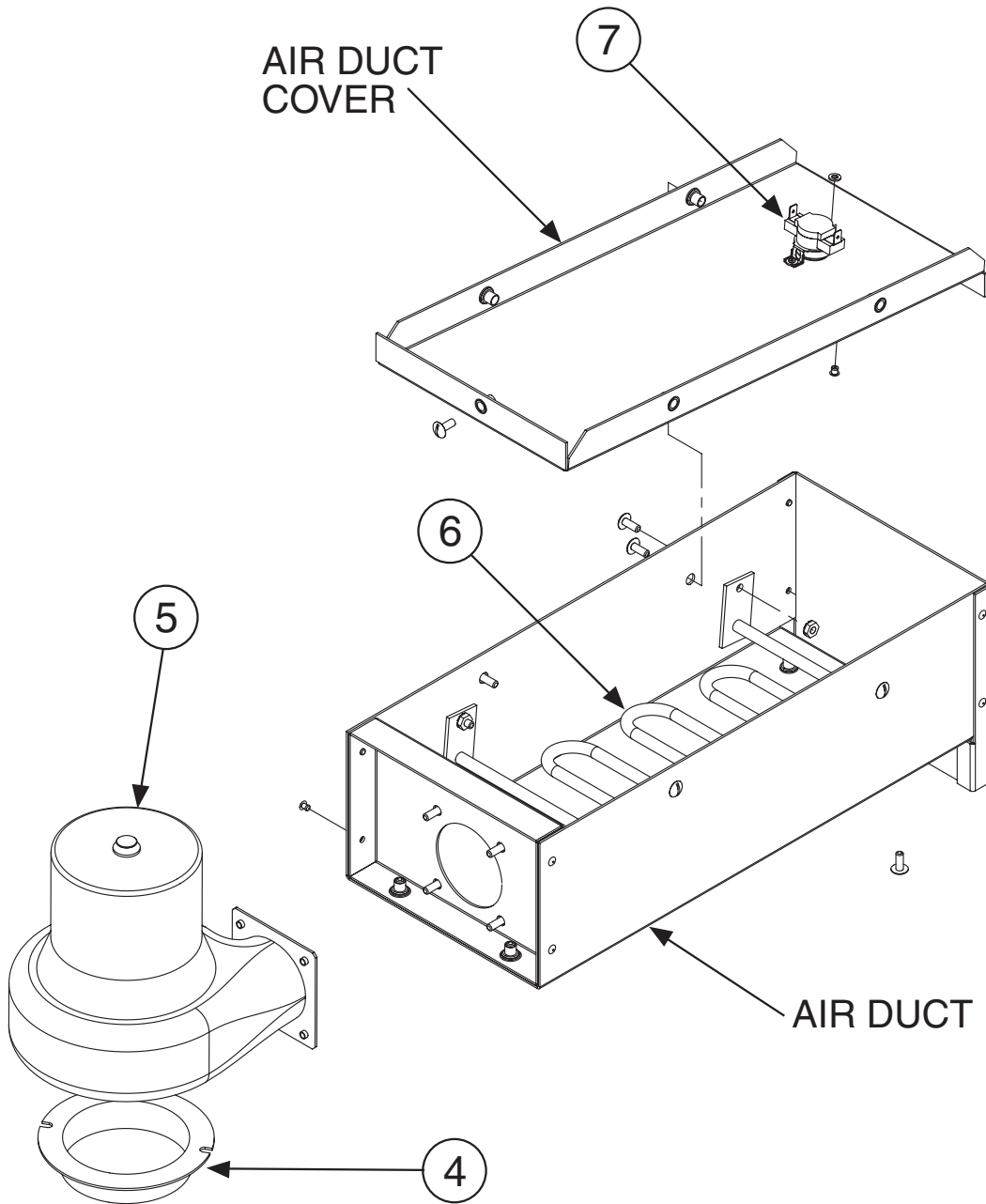

AIR DUCT

SERVICE and REPLACEMENT PARTS (continued)

Warning: Only factory approved service agents should attempt to service, repair or replace electrical components, wiring or power cord.

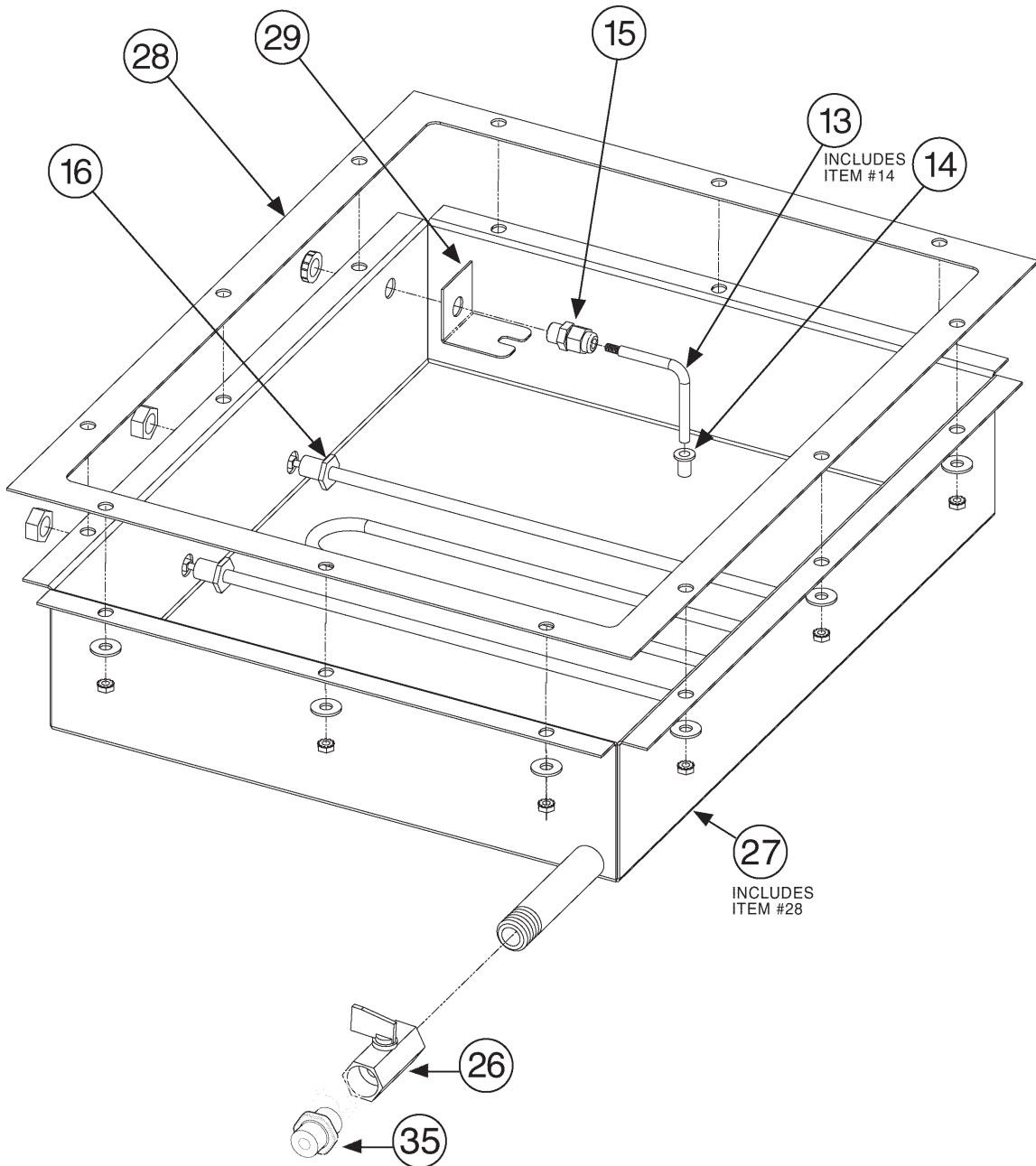

WATER RESERVOIR

SERVICE and REPLACEMENT PARTS (continued)

Warning: Only factory approved service agents should attempt to service, repair or replace electrical components, wiring or power cord.

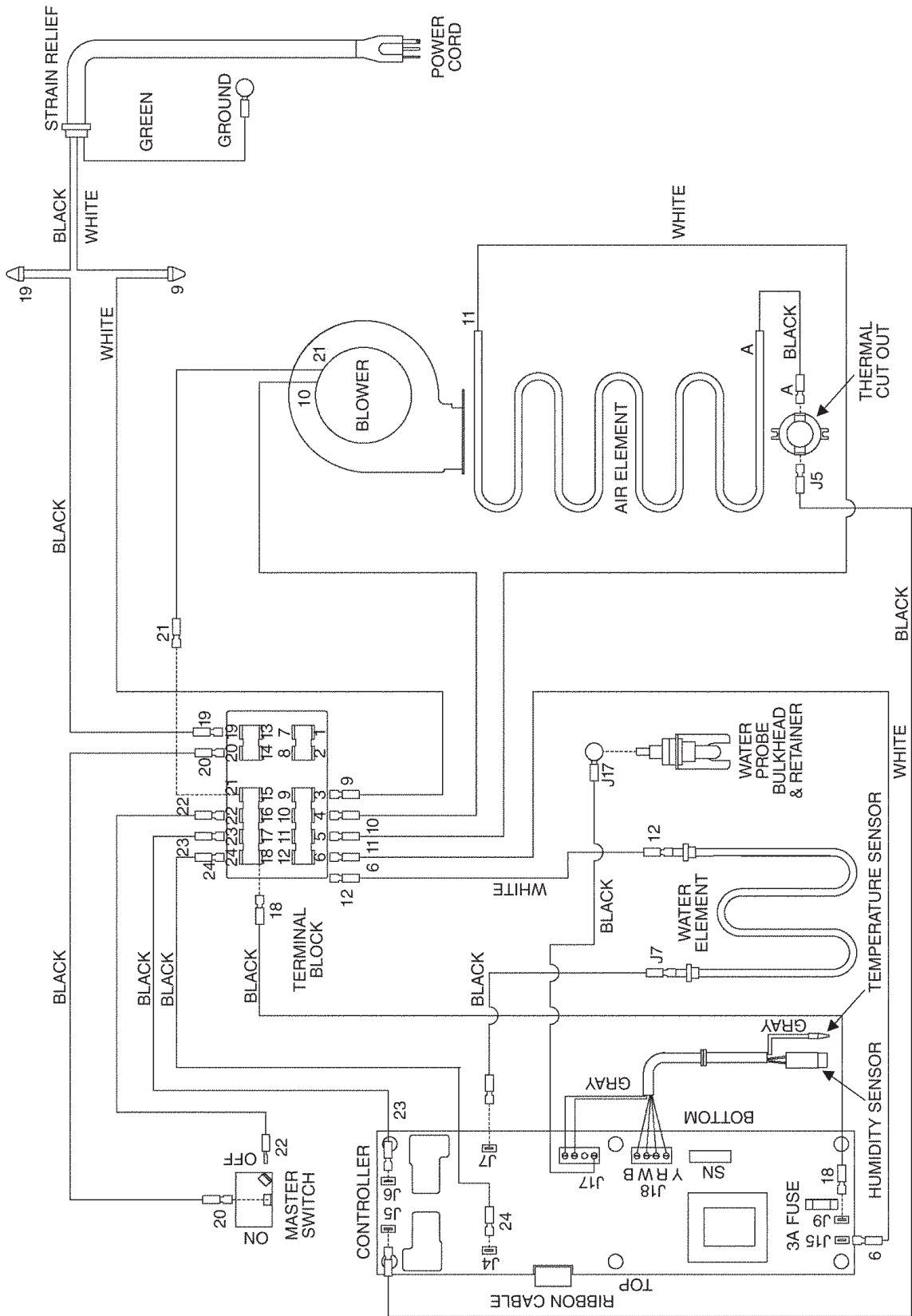

Thank you for purchasing a Metro C5 Controlled Humidity Cabinet. We are certain you will be more than satisfied with its quality and performance. Please fill in the warranty information space below so we may register your warranty. Also, so that we may learn more about our customers and hopefully be of continued service in the future, please take a moment to fill in the customer information space below.

Thank You

CUT ALONG DOTTED LINE

CUSTOMER INFORMATION

1. Which one of the following best describes your establishment?

- a. Full-Service Restaurant
- b. Banquet Hall
- c. Hotel/Motel
- d. Hospital/Nursing Home
- e. College/University
- f. School
- g. Employee Feeding
- h. Other _____

WARRANTY INFORMATION:

Cabinet Model No. _____
Cabinet Serial No. _____
Date Purchased _____
Customer Name _____
Address _____

Phone No. _____

For warranty coverage, this card must be returned to Metro.

FOLD HERE — DO NOT DETACH

2. Please indicate the two product benefits that were of major interest to you.

- a. Easy-to-use controls
- b. Humidity readout
- c. Door selection
- d. Bumper/Drip Trough
- e. Size Selection
- f. Cabinet capacity
- g. Slide selection
- h. Easy-to-clean design
- i. Other _____

3. Main factor that led to your decision to purchase this product?

- a. Product operating and functional features
- b. Overall quality
- c. Price
- d. Availability
- e. Other _____

4. Three sources that led to the purchase of his product — in the order of their impact (1 — being most impact; 3 — being least impact).

- a. Trade Journal Ad
- b. Trade Show
- c. Sales Call
- d. Direct Mail
- e. Previous Purchase
- f. Other _____

CUT ALONG DOTTED LINE



INTERMETRO INDUSTRIES CORPORATION
 ATTN: CUSTOMER SERVICE
 P O BOX A
 WILKES-BARRE PA 18705-9968

POSTAGE WILL BE PAID BY

BUSINESS REPLY MAIL
 FIRST-CLASS PERMIT NO. 121 WILKES-BARRE, PA



NO POSTAGE
 NECESSARY
 IF MAILED
 IN THE
 UNITED STATES

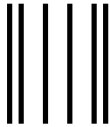

FOLD HERE — DO NOT DETACH

STAPLE HERE

STAPLE HERE

STAPLE HERE

Warranty

WARRANTY, EXCLUSION OF WARRANTIES AND LIMITATION OF LIABILITY.

InterMetro Industries Corporation (hereinafter referred to as "Seller") warrants to the original purchaser that all products in its catalog, or custom products, delivered hereunder will be free from defects in workmanship and material. THE FOREGOING WARRANTY IS EXCLUSIVE AND IN LIEU OF ALL OTHER WARRANTIES, EXPRESS, IMPLIED OR STATUTORY, INCLUDING ANY WARRANTY OF MERCHANTABILITY OR FITNESS FOR A PARTICULAR PURPOSE. This Warranty shall be for a period of one (1) year from the date of shipment from Seller's warehouse or factory. If any product delivered hereunder does not meet the Warranty specified above, providing the product has not been altered in any way by anyone other than Seller's factory-authorized representative, and assuming normal and proper use and maintenance, Seller will, at its option, repair or replace any part or material it determines, upon inspection, to be defective; provided however, that a charge for labor will be made except during a period of one (1) year from the date of original shipment from Seller's warehouse or factory. No product, or part thereof, is to be returned to Seller without prior written approval from Seller's factory. All exchanges and replacement shipments will be F.O.B. Seller's factory. Warranties for equipment or articles not manufactured by the Seller are solely the warranties of the manufacturers thereof and they are hereby assigned to the purchaser without recourse to the Seller.

SELLER'S LIABILITY FOR ANY CLAIM OF ANY KIND, WHETHER BASED ON CONTRACT, NEGLIGENCE OR STRICT LIABILITY IN TORT, AND BY WHOMEVER MADE, FOR ANY DIRECT, INDIRECT, INCIDENTAL OR CONSEQUENTIAL LOSS, DAMAGE OR INJURY, RESULTING TO THE PURCHASER OR ANY THIRD PARTIES, arising out of, connected with or resulting from this Agreement, or from the performance or breach thereof, or from the manufacture, sale, delivery, resale, installation, inspection, repair or use of any product covered by or furnished under this Agreement, WHETHER OR NOT CAUSED BY SELLER'S NEGLIGENCE, SHALL IN ALL EVENTS BE EXCLUSIVELY LIMITED TO THE COST OF CORRECTING DEFECTIVE, DAMAGED OR NON-CONFORMING PARTS OR MATERIAL AS HEREIN PROVIDED, and upon the expiration of one (1) year, all such liability shall terminate.

SELLER DOES NOT AUTHORIZE any person to assume for it any obligations or liabilities greater than or different than those set forth in this Warranty. The terms under which any of Seller's products may be resold must be limited in accordance with this Warranty.

THIS AGREEMENT, and all the rights and obligations arising hereunder, shall be construed in accordance with, and be governed by, the law of the Commonwealth of Pennsylvania, U.S.A.

TO INSURE WARRANTY implementation, return the completed registration card within 15 days of cabinets' receipt to: InterMetro Industries Corp., Wilkes-Barre, PA 18705



InterMetro Industries Corporation
Wilkes-Barre, PA 18705



InterMetro Industries Corporation
North Washington Street, Wilkes-Barre, PA 18705
For Product Information Call: 1-800-433-2232
Visit Our Web Site: www.metro.com

L01-419
Rev. A
05/06

Information and specifications are subject to change
without notice. Please confirm at time of order.