



Yes, you can.[®]

Invacare[®] **Alegio**[™]

User's Manual



CE

Quality Declaration

Congratulations with your new bed Invacare® Alegio™ from Invacare®.

Your new bed is **CE**-marked in accordance with directive 93/42/EEC concerning medical devices.

Invacare® Alegio™ is developed and constructed with consideration for the user and others handling or assisting at the bed. Furthermore, the bed is developed in accordance with the European Standard EN 1970.

Invacare® Alegio™ is supervised and quality controlled throughout the entire production process, and the finished bed is inspected by our finished goods control. Identification label are located on the bed confirming that the finished goods control has approved the bed.

Please read the entire user's manual before using the bed.

Invacare® France Operation SAS is certified according to ISO 9001 and ISO 13485.

For and on behalf of Invacare® France Operation SAS:

A handwritten signature in black ink, appearing to read 'Eric Michel', is written over a solid horizontal line.

Eric Michel
Managing Director

DK

KVALITETSDEKLARATION

Tillykke med Deres nye seng *Invacare*[®] **Alegio**[™] fra *Invacare*[®] France Operation SAS.
Deres nye seng er CE - mærket og lever op til alle krav i henhold til direktiv 93/42/EØF om medicinske anordninger.
Sengen er udviklet og konstrueret under størst mulig hensyntagen til brugeren samt alle andre, der enten håndterer sengen eller hjælper til ved sengen.
Invacare[®] **Alegio**[™] er udviklet under hensyntagen til de sikkerhedsmæssige krav i den Europæiske Standard EN 1970. Hver seng har gennem hele produktionsforløbet været overvåget og kontrolleret, og den færdige seng er blevet inspiceret af vores færdigvarekontrol.
Typeskilt påsættes sengen som dokumentation for, at færdigvare kontrollen har godkendt sengen. Før ibrugtagning af Deres seng skal De gennemlæse brugermanualen grundigt.
Invacare[®] France Operation SAS er certificeret i henhold til ISO 9001 og ISO 13485.

DE

QUALITÄTSDOKUMENTATION

Herzlichen Glückwunsch zu Ihrem neuen Pflegebett *Invacare*[®] **Alegio**[™] von *Invacare*[®] France Operation SAS.
Ihr neues Pflegebett ist gemäß der Richtlinie 93/42/EWG für Medizinprodukte CE-gekennzeichnet.
Der *Invacare*[®] **Alegio**[™] wurde unter Berücksichtigung der Bedürfnisse von Benutzer und Pflegepersonal entwickelt und in Übereinstimmung mit der Europäischen Norm EN 1970 konzipiert und hergestellt.
Während des gesamten Herstellungsprozesses unterliegt der *Invacare*[®] **Alegio**[™] einer ständigen Qualitätskontrolle und wird im Anschluss nochmals durch unsere Endkontrolle geprüft.
Das Typenschild sind am Bett angebracht, um die Abnahme durch unsere Qualitätskontrolle zu bestätigen.
Bitte lesen die gesamte Bedienungsanleitung, bevor Sie den Bett in Gebrauch nehmen.
Invacare[®] France Operation SAS ist zertifiziert nach ISO 9001 und ISO 13485.

NL

KWALITEITSGARANTIE

Gefeliciteerd met de aanschaf van uw nieuwe bed **Alegio**[™] van *Invacare*[®] EC- Hong A/S.
Invacare[®] **Alegio**[™] is CE - gecertificeerd en goedgekeurd conform richtlijn 93/42/EEC betreffende medische hulpmiddelen.
Invacare[®] **Alegio**[™] is ontwikkeld en geconstrueerd met inachtneming van de behoeften van de gebruiker en verzorgers.
Invacare[®] **Alegio**[™] is ontwikkeld in overeenstemming met de Europese Standaard EN 1970.
Gedurende het gehele productieproces is het **Alegio**[™] bed gecontroleerd op kwaliteitsaspecten en het complete bed is na productie zorgvuldig gecontroleerd. Het productlabel zijn op het bed bevestigd om aan te tonen dat de bedden zijn gecontroleerd en goed zijn bevonden door de afdeling productcontrole. Wij verzoeken u vriendelijk de gehele gebruikershandleiding te lezen voordat u het bed in gebruik neemt.
Invacare[®] France Operation SAS is ISO 9001 en ISO 13485 gecertificeerd.

IT

DICHIARAZIONE DI QUALITÀ

Complimenti per aver scelto il letto *Invacare*[®] **Alegio**[™] prodotto da *Invacare*[®] France Operation SAS.
Il vostro nuovo letto è marcato CE - ai sensi della Direttiva 93/42/EEC relativa ai dispositivi medici.
Il letto è stato progettato e costruito con un occhio di riguardo per gli utilizzatori e per i loro assistenti. *Invacare*[®] **Alegio**[™] è stato realizzato nel rispetto della Normativa Europea EN 1970.
Il letto è stato oggetto di accurate verifiche qualitative durante l'intero processo produttivo; una volta completato è stato controllato dal nostro servizio prodotti finiti.
Un'apposita targhetta sono state apposte sul letto a conferma dell'avvenuta verifica e accettazione del prodotto da parte del servizio qualità. Prima di utilizzare il letto vi invitiamo a leggere integralmente il manuale d'uso.
Invacare[®] France Operation SAS è un'azienda certificata ai sensi della Normativa ISO 9001 e ISO 13485.

ES

DECLARACIÓN DE CALIDAD

Enhorabuena por su nueva cama *Invacare*[®] **Alegio**[™] de *Invacare*[®] France Operation SAS.
Su nueva cama cuenta con el marcaje CE - de acuerdo a la directiva 93/42/EEC que hace referencia a los aparatos médicos.
Invacare[®] **Alegio**[™] ha sido diseñada y fabricada teniendo en cuenta a los usuarios y las personas que los asisten.
La cama *Invacare*[®] **Alegio**[™] ha sido diseñada de acuerdo a la normativa Europea EN 1970.
El proceso de producción del modelo *Invacare*[®] **Alegio**[™] ha sido supervisado en su totalidad y su calidad inspeccionada, por nuestro control de producto acabado.
La cama cuenta con una placa y marca CE que confirma que la misma ha sido inspeccionada por el control de producto acabado. Por favor lea el manual antes de utilizar la cama.
Invacare EC-Hong A/S es una empresa certificada ISO 9001 e ISO 13485

FR

DÉCLARATION DE QUALITÉ

Félicitations! Vous avez choisi votre nouveau lit *Invacare*[®] **Alegio**[™] de *Invacare*[®].
Votre nouveau lit est marqué CE conformément à la directive 93/42/EEC concernant les dispositifs médicaux.
Invacare[®] **Alegio**[™] a été développé et construit en considérant systématiquement les besoins de l'utilisateur et des tierces personnes lors de la manipulation du lit ou de son utilisation.
Invacare[®] **Alegio**[™] a été développé conformément au Standard Européen NF EN 1970 et NF EN 60601-2-38.
Invacare[®] **Alegio**[™] a été supervisé et contrôlé tout au long du processus de fabrication et le lit achevé a été inspecté par le contrôle des produits finis. La plaque d'identification sur le lit attestant que le contrôle des produits finis a approuvé le lit. Le lit répond aux exigences de l'analyse de risques de la norme NF EN 14971.
Nous vous remercions de lire le Manuel de l'Utilisateur dans son intégralité avant d'utiliser le lit.
Invacare[®] est certifiée ISO 9001 et ISO 13485.

PT

DECLARAÇÃO DE QUALIDADE

Parabéns pela sua nova cama *Invacare*[®] **Alegio**[™] da *Invacare*[®] France Operation SAS.
A cama tem a marca CE - em conformidade com a directiva 93/42/EEC referente a aparelhos médicos.
A cama foi concebida e desenhada, tendo em consideração o seu utilizador e o seu(s) assistente(s), que o ajudarão a manipular a cama. A cama foi concebida em conformidade com o Standard Europeu EN 1970.
Durante todo o processo de fabrico e produção, a cama *Invacare*[®] **Alegio**[™] foi supervisionada e a sua qualidade controlada, sendo o produto final inspeccionado e testado pelo nosso controlo de qualidade. As etiquetas são colocadas na cama, após a aprovação final da cama, confirmando e garantindo a conformidade com o nosso controlo de qualidade. Por Favor, leia atentamente este manual de utilizador antes de utilizar a sua cama.
A *Invacare*[®] France Operation SAS está certificada em conformidade com ISO 9001 e ISO 13485.

Table of contents

User's part	8
1. In general	8
2. Operating the Invacare® Alegio™	8
Technical part	11
3. Product information	11
4. Safety guidelines	11
5. Dismounting/mounting the Invacare® Alegio™	12
6. Removal of cables from the control unit	15
7. Mounting/dismounting the accessories	16
8. Emergency lowering of the backrest and/or thigh section	17
9. Operating the accessories	17
10. Accessories	18
11. Cleaning	19
12. Maintenance and check-ups	19
13. Maintenance chart	20
14. Disposal	20
15. Trouble-shooting the electrical system	21
16. Technical specifications	22
17. Electrical data	23
18. Weights	23

User's part

Congratulations with your choice of the *Invacare*[®] **Alegio**[™] nursing bed.

- The *Invacare*[®] **Alegio**[™] is designed for patients over the age of 12 years especially for home care.
- The *Invacare*[®] **Alegio**[™] combines excellent stability and ergonomic design with easy disassembly and operation.

In order to optimise the patient's comfort, *Invacare*[®] France Operation SAS recommends using a 17 cm mattress.

1. In general

Please read the entire User's part carefully before using the bed.

All indications of right and left are based on a patient lying on the back in the bed.



Invacare[®] France Operation SAS accepts no liability for any use, change or assembly of the product other than as stated in this User's Manual.



The bed must not be used by patients under 12 years of age, or by patients with body size equivalent to an average 12-year-old or smaller.

2. Operating the *Invacare*[®] **Alegio**[™]

Height adjustment and installation of legs

Height adjustment of the bed is done by tilting the bed, removing the cotter and clevis pin, adjusting the inner leg position, and reinstalling the clevis and cotter pin.

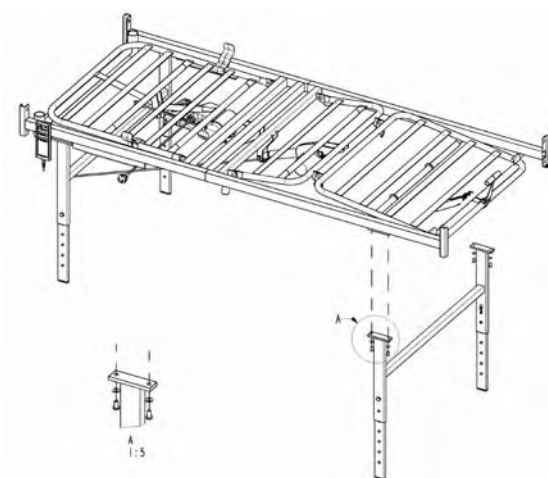

The bed legs are installed with the enclosed M8X16 screws and the according washers.

Operating the hand control

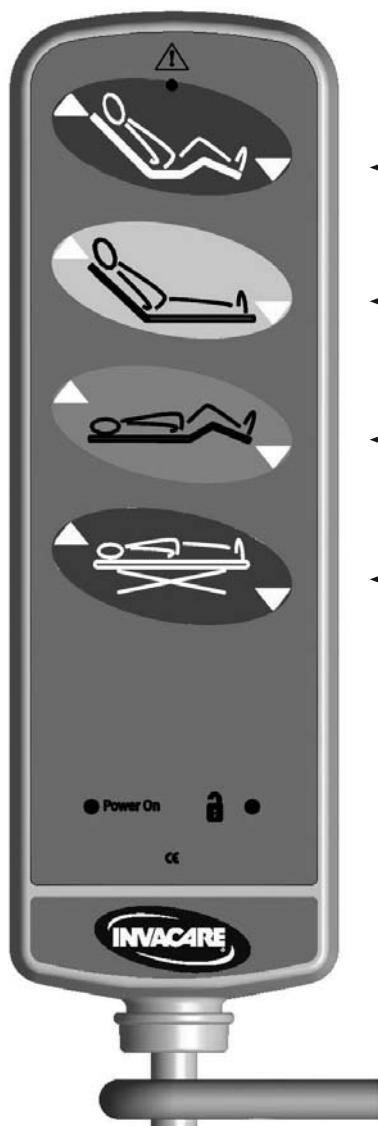

- ← **Sitting position (green button) - up/down**
(Only 4-sectioned beds)
Use the button with the symbol shown on the left.
- ← **Adjustment of backrest - up/down**
Use the button with the symbol shown on the right.
- ← **Adjustment of the thigh section - up/down**
(Only 4-sectioned beds)
Use the button with the symbol shown on the right.
- ← **Height adjustment of mattress section - up/down**
NB! Not applicable to beds with manual leg adjustment.

Adjustment of leg section (only on 3-sectioned beds)

Operate the leg section by lifting the mattress handle.

Up: Lift the mattress handle on the leg section.

Down: Lift the mattress handle on the leg section all the way up and then lower the leg section.

If a mattress support extension is used, lift the leg section.

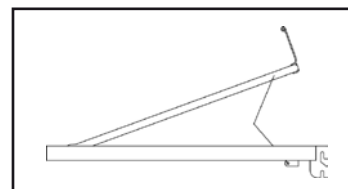

Locking function on the hand control (accessory)

Power-on indicator

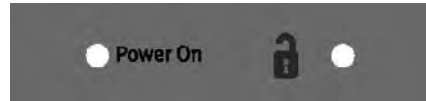

LED on: Hand control is unlocked
LED off: Hand control is locked

You can respectively lock and unlock the functions of the hand control by sliding the magnetic lock forwards and backwards pass the padlock icon. The magnetic lock is fastened on the hand control cable, at delivery.





When any button on the hand control is pressed, the  -indicator lights up.

After connecting the mains cord, the hand control will be locked, and should be unlocked before operation.

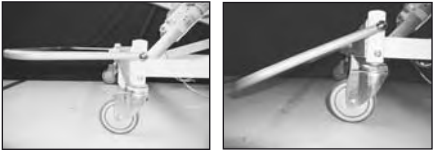

Always leave the bed in the lowest position. Otherwise there is a risk of entrapment due to accidental lowering of the mattress support. A person under the bed can be seriously injured during height adjustments.

Operating the braking castors

<p>Operating castors without central braking system</p> <p>When the bed is positioned correctly, at least one castor at the head end and one castor at the foot end must be locked.</p> <p>1) Braking: Step on the pedal. 2) Releasing the brake: Step on the release pedal.</p>	
<p>Operating castors with central braking system</p> <p>When the bed is positioned correctly, the castors must be locked.</p> <p>1) Braking: Step on the pedal. 2) Releasing the brake: Lift the pedal, until the brake is released.</p>	
<p>Operating castors with central braking system</p> <p>When the bed is positioned correctly, the castors must be locked.</p> <p>1) Braking: Step on the pedal. 2) Releasing the brake: Lift the pedal, until the brake is released.</p>	
<p>Operating the steerable castor</p> <p>The Alegio™ with central braking system may be equipped with a steerable castor.</p> <p>The steerable castor is operated by means of the central braking pedal.</p> <p>1) Activating the steering: If the brake is in neutral, step on the green pedal. 2) Deactivating the steering: Step on the red pedal, until the brake is in neutral position.</p>	

Set-off from the castors might under special conditions appear at different types of absorbing floor covering - including untreated or badly treated floors. In matters of doubt, *Invacare®* recommends to place a suitable kind of protection between the castors and the floor.

Technical part

Invacare® France Operation SAS is certified according to DS/EN ISO 9001/ISO 13485 which ensures our customers are always supplied with products of uniform quality.

Throughout the entire production process our materials/products are quality controlled by the operators. Furthermore there is a final test when the product is fully assembled.

If the product does not correspond to the quality demands of *Invacare*® France Operation SAS, it will be discarded.

Please contact your *Invacare*® supplier if, contrary to our expectations, a problem should arise in connection with the delivered product.

3. Product information

Please read the entire technical part carefully before using or servicing the bed.

All indications of right and left are based on a patient lying on their back in the bed.

- The *Invacare*® **Alegio**™ is CE- marked in accordance with directive 93/42/EEC concerning Medical Apparatus.
- The motors and the control box of the *Invacare*® **Alegio**™ are approved according to EN 60601:1996-03.
- The *Invacare*® **Alegio**™ has undergone a risk analysis according to EN 14971.

The control unit, motors and hand control are protected according to IP 66. A lock cam **must** be used on the control unit, otherwise *Invacare*® France Operation SAS cannot guarantee the protection.

Max. load: 170 kg – max. patient weight: 135 kg. Max. load is stated on the identification label.

NOTE! The max. load of the bed must not be exceeded.

4. Safety guidelines



Disconnect the plug from the mains before moving the bed. The cables must be kept clear off the floor and the castors during transport.



Make sure that the mains cord cannot be jammed or in any other way damaged, when the bed is used.



The brakes of the bed must be activated during nursing of a patient in the bed and when the bed is adjusted.



Adjust all mattress support sections to a horizontal position before transporting an assembled bed. Hold the top of the bed end with both hands while the bed is pushed/pulled.

Only personnel who have been trained or instructed by *Invacare*® may perform the service work described in this manual in the chapters 13 and 14.

If the functions of the bed change, check the bed according to chapter 14.

The *Invacare*® *Alegio*™ must be stored in a room with a humidity of 10 - 80%, RH within a temperature of 0 - 50°C.

5. Dismounting/mounting the *Invacare*® *Alegio*™

Dismounting the *Invacare*® *Alegio*™

1. Brake the bed and bring it to its lowest position and then about 5 cm up.
2. Remove the accessories: Siderails, bed ends and lifting pole.
3. Dismount the finger screws at both sides (see illustration A).
4. Dismount the cable from the lifting motor/leg section (see illustration B).
5. Dismount the top frame at the head end and place it in a vertical position (see illustration C and D).
6. Lift the leg section and dismount the pipe pins (see illustration E).
7. Dismount the top frame at the foot end and place it in a vertical position (see illustration F).
8. Dismount the shear arm (see illustration G, H, I, J and K).

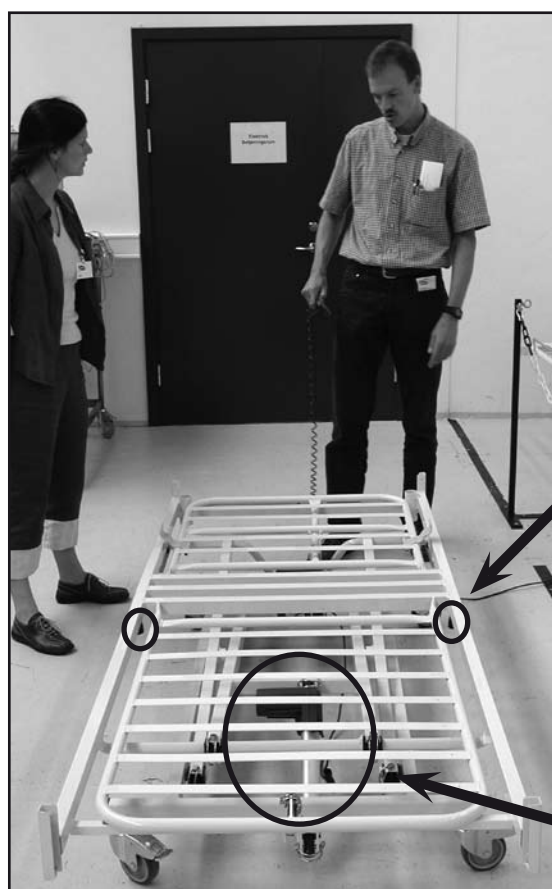

A)

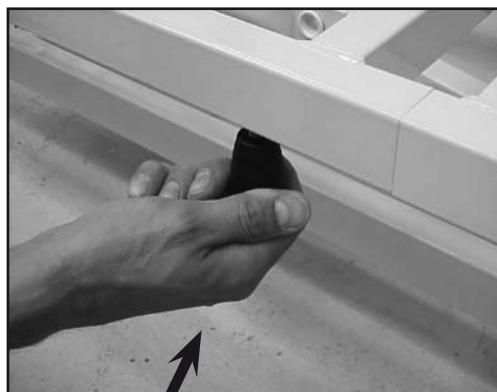

Finger screw

B)



C)

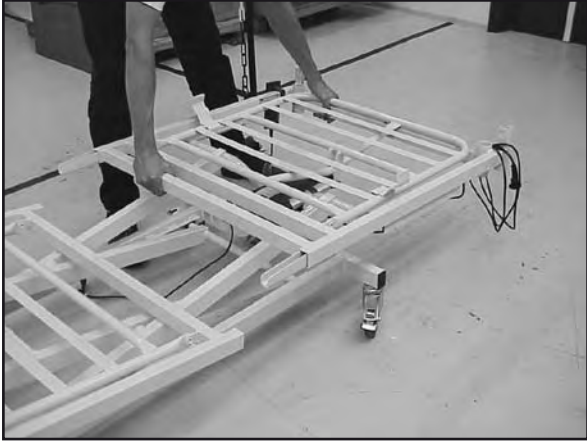

D)

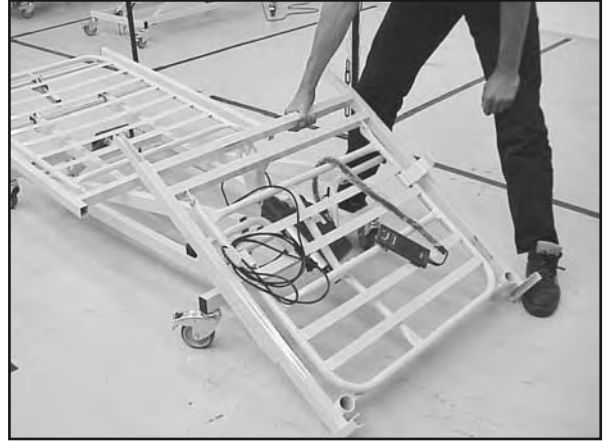

E)



F)

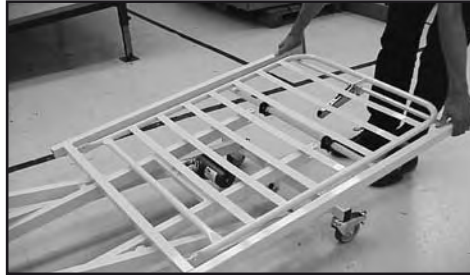

G)



H)

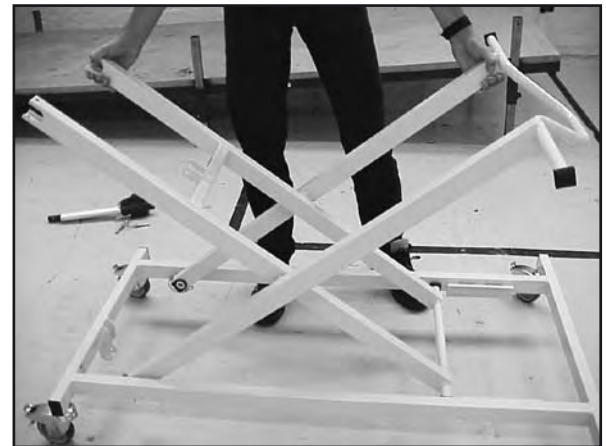

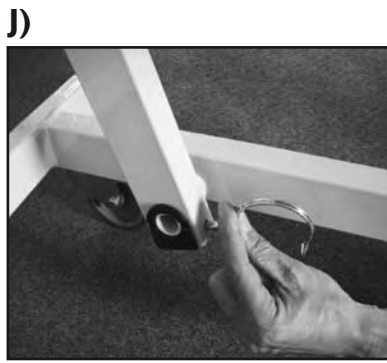

Mounting the *Invacare® Alegio™*

1. Mount the shear arm (see illustration K, J, I, H and G).
2. Mount the leg section and the pipe pins, ensuring that the spring clip is securely latched over the end of the pin (see illustration F and E).
3. Mount the head section (see illustration D and C).
4. Push the head section into the leg section (see illustration L).
5. Mount the cable for the lifting motor/leg section (see illustration B).
6. Mount the finger screws in both sides (see illustration A).
7. Mount the accessories: Siderails, bed ends and lifting pole.



Caution! Please ensure that the pipe pins are fully inserted through both holes of the tubular section, and that the spring clip is fully engaged prior to operating the lifting mechanism on the bed. Furthermore, please ensure that all four plastic bushings are intact and located correctly between shear arm/base and shear arm/top frame.

NB! Do not pull the clamp part of the pipe pin during dismantling – the clamp may be deformed, thus being unable to lock properly.

Mounting of the pipe pin between shear arm and base

The pipe pin must be mounted with the opening upwards and locked.

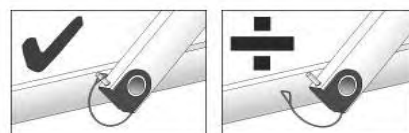

6. Removal of cables from the control unit

Raise the bed to highest position and remove the mains cord from the socket outlet.



Use a small tool (such as screwdriver) to release the pawl on the locking cam.



Hold the locking cam while releasing the remaining pawls.



With all pawls released, the locking cam can be removed from the control unit.

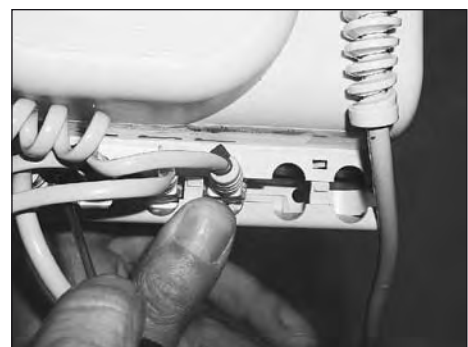

Motor connections are indicated on the label behind the cables.



7. Mounting/dismounting the accessories



Risk of entrapment of fingers during assembly and operation of the bed end and side rail.

Mounting the Vibeke bed end and Verso side rail

1. Lower the bed ends into the U-profiles.
2. Place the side rail with the release system in the leg end, and tighten both finger screws.

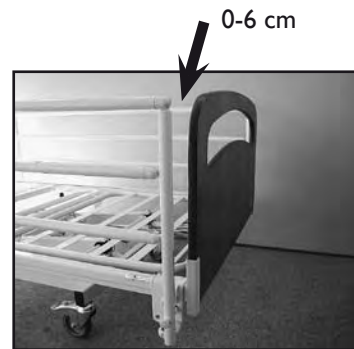
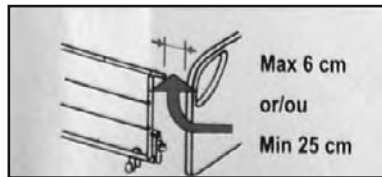

Mounting the Kirsty bed end and Nina side rail

1. The bed end is mounted as shown on illustration A - push the bed end all the way down, and secure it with the two finger screws (see illustration B).



2. Raise the mattress support to approximately 1/3 from lowest position.
3. Remove the side rail stopping bracket and finger screws (see illustration C).
4. Remove the protective tape from the locking dowels in each end of the side rail.
5. Install one end at a time. Lift the lower wooden rail with one hand while guiding the metal bow into the bed end bar (see illustration D).
6. Press the locking pin of the side rail with one finger.
7. Raise the side rail until the locking pin engages with an audible click, thus preventing the side rail from falling down.
8. Re-install the side rail stopping bracket and finger screws (see illustration C).



Mounting the lifting pole

Lower the lifting pole into the lifting pole tube. The lifting pole **MUST** be fastened with a finger screw.

8. Emergency lowering of the backrest and/or thigh section



A minimum of 2 persons are required to release a mattress support.

Remove the plug from the mains before emergency lowering of the mattress support.
In an emergency, the mattress sections are released by pulling out the cotter pin from the motors.

Two persons hold the mattress section in locked position. One of them pulls out the cotter pin. Both slowly lower the mattress section until it is complete down.



9. Operating the accessories

Operating the Verso side rail

Up: Pull the release button while lifting the top tube of the side rail, and release the button to engage the lock.

Down: Pull the release button while pushing the top tube away from the release system.

NB! Depending on the position of the castor, the side rail might touch the castor at the head end.

Operating the Nina side rail

Up: Pull up the top wooden siderail bar, until the locking pins engages with an audible click.

Down: Lift the top wooden siderail bar while pressing the two locking pins together. Lower the siderail.

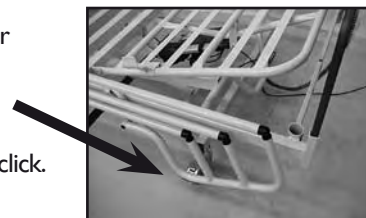

There is a risk of entrapment while operating the side rails.

Adjusting the height of the lifting pole handle

Loosen the cord as shown in ill. A. The lifting handle can now be adjusted to the desired height. Press the cord together as shown in ill. B and check that the cord is secured in the cord lock by pulling the handle.



A



B



Position the lifting pole in such a way that the handle extends inwards across the bed. If the handle has been turned away from the bed while the lifting pole is being used, the bed can tip.

Max. load of the lifting pole: 80 kg.

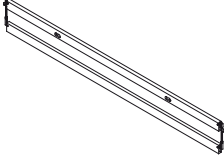
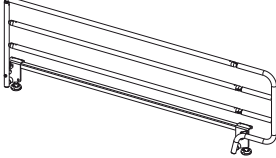
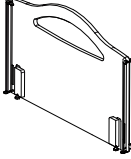
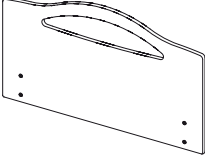
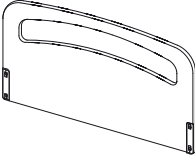
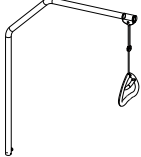
10. Accessories

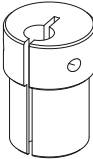
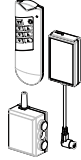
Article	
Nina wooden side rail - 1 pair	
Verso steel side rail - 1 pair	
Kirsty wooden bed end with slide bars - 1 pair	
Kirsty wooden bed end - 1 pair	
Vibeke wooden bed end (high) - 1 pair	
Lifting pole	
Hand control support	
IV drip rod	
Support for IV drip rod	
IR handset	

Please only use original spare parts.

Spare parts lists and extra user manuals for the *Invacare*® **Alegio**™ can be ordered from *Invacare*®.

11. Cleaning

The *Invacare® Alegio™* does not tolerate cleaning in automatic washing plants or using water jet based cleaning equipment.

The bed is washed down using a sponge, cloth or brush. Use ordinary disinfecting detergents.

Dry the bed after cleaning.

Never use acids, alkalines or solvents such as acetone or cellulose thinner.

The hand control, motors and the control box can be wiped with a moist cloth (the water temperature must be below 30° C).

When cleaning: Bring the backrest to its top position. Bring the bed to its top position. Disconnect the power cord by pulling the plug from the socket outlet before cleaning the bed. The risk of entrapment of fingers is minimised, as accidental elevation of parts of the bed is not possible.

12. Maintenance and check-ups

Only personnel who have received the necessary instruction or training may perform service and maintenance on the *Invacare® Alegio™*.

After 3 months of use the following must be checked:

- Tightening of the finger screws at the inserts in the middle of the bed.
- Fastening of the side rail - locking system and moving system.

With normal operation, the first service inspection is required after 2 years and thereafter every second year, according to the maintenance chart shown in chapter 14.

Please note:

The mattress support must be supported during service inspections to prevent accidental lowering.

Motors, control unit and hand control

These parts are serviced by exchanging the faulty part.

Motors, control unit and hand control must be regularly cleaned from dust and dirt and must be inspected for mechanical damage or breakage.

Inspect anchor points, cables, piston rod, casing and plugs and check the correct functioning of the motor.

13. Maintenance chart

<p>Only personnel who have received the necessary instruction or training may perform service and maintenance on the <i>Invacare</i>® <i>Alegio</i>™</p> <p>S/N (located on mattress support): _____</p>				
What to check for:	Date:			
Check the side rails' mounting and locking/movement.				
Check mounting and braking of wheels.				
Check height adjustment motor - suspension, and performance.				
Check backrest and leg rest motor - suspension and performance.				
Check that cables and plugs are undamaged.				
Check rastofix fitting and its function.				
Check weldings.				
Have damaged coating repaired.				
<p>Lubrication performed:</p> <ol style="list-style-type: none"> 1. Points of rotation in mattress support and base frame, with oil. 2. All of the motors' tension rods, with oil. <p>Lubricate with medically clean oil, e.g. KEN-WO 50, order no.: 813239. NB! The wooden side rails' gliding system must not be lubricated with oil - otherwise the wooden bars will move sluggishly.</p>				

A service contract can be made in countries where *Invacare*® has its own sales company. Furthermore, *Invacare*® offers courses in service and maintenance of the *Invacare*® *Alegio*™.

14. Disposal

This product has been supplied from an environmentally aware manufacturer that complies with the Waste Electrical and Electronic Equipment (WEEE) Directive 2002/96/CE.

This product may contain substances that could be harmful to the environment if disposed of in places (landfills) that are not appropriate according to legislation.

The 'crossed out wheelie bin' symbol is placed on this product to encourage you to recycle wherever possible.

Please be environmentally responsible and recycle this product through your recycling facility at its end of life.

15. Trouble-shooting the electrical system

Only personnel who have received the necessary instruction or training may perform service and maintenance on the *Invacare® Alegio™*.

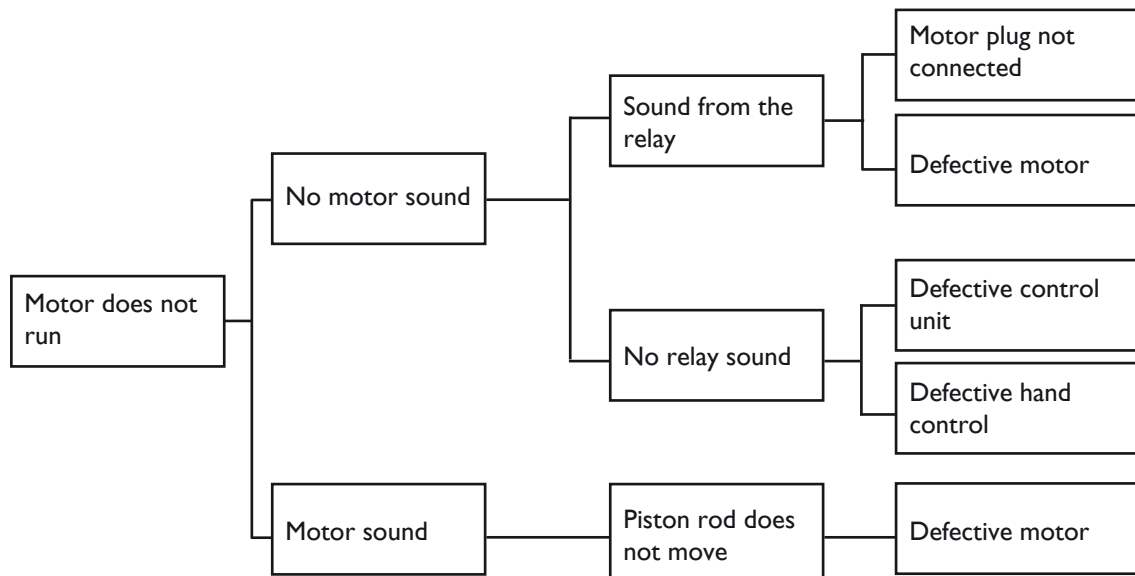

16. Technical specifications

All measurements are given in cm. All angles are stated in degrees. All measurements and angles are stated without tolerances.

Invacare® reserves the right to change the stated measurements and angles.

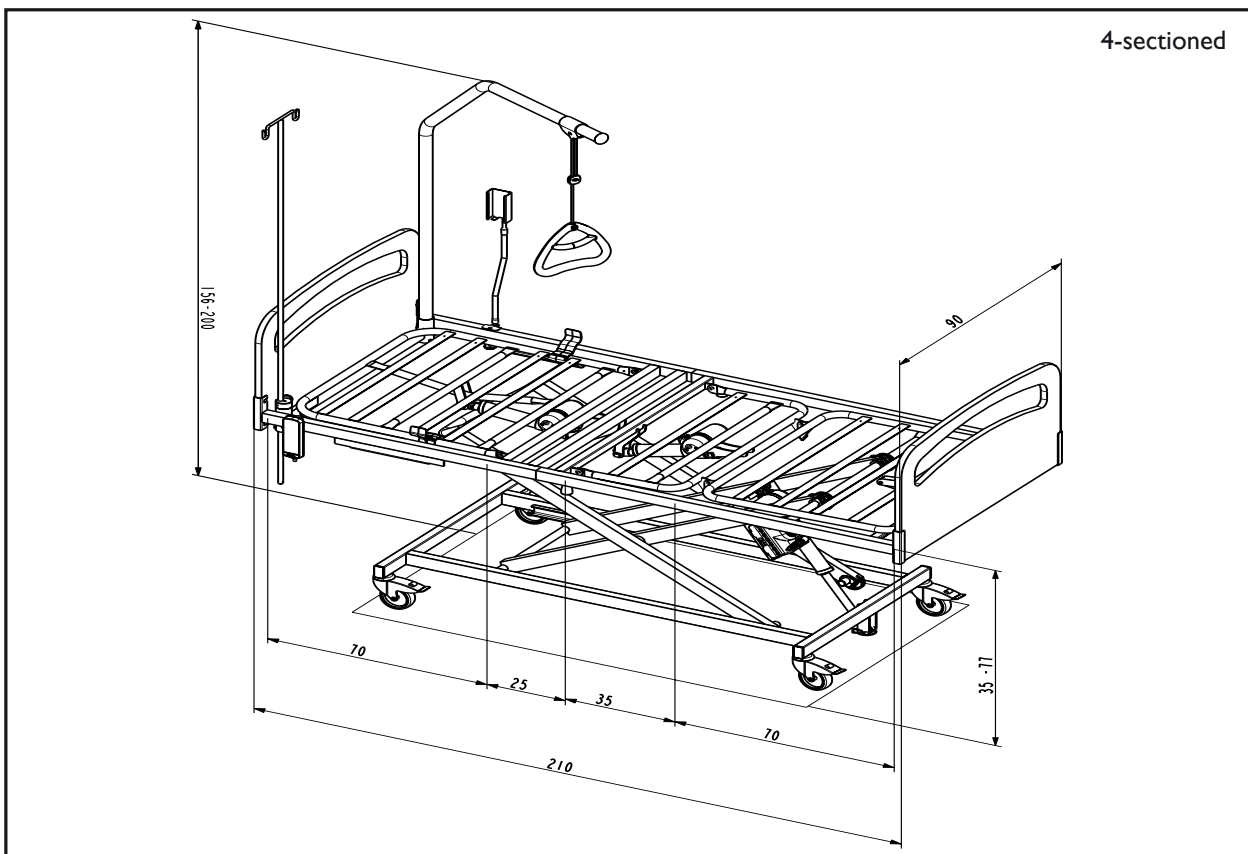
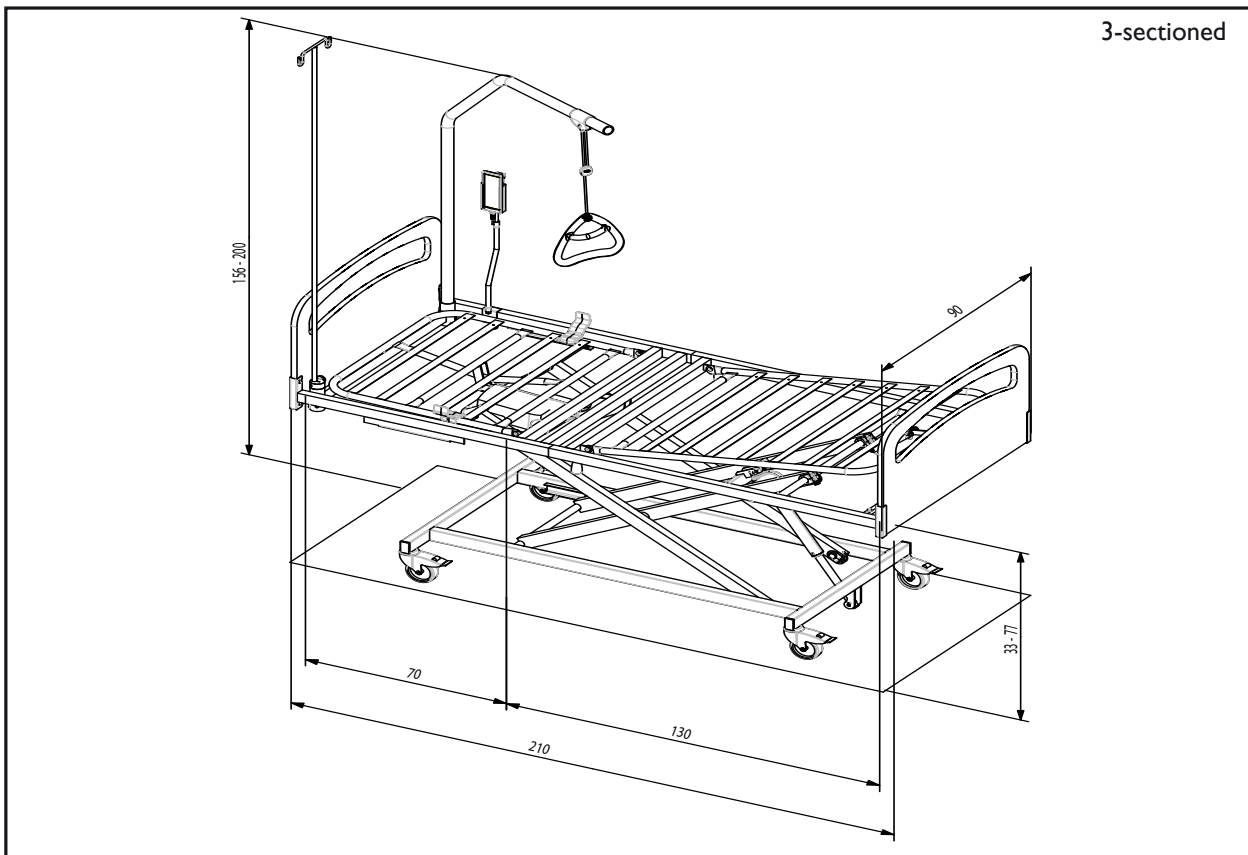

17. Electrical data

Voltage supply: 230 V± 10%, 50 Hz.

Max. current input: 0,8 A.

Voltage output: 24 V.

Intermittent (periodic motor operation): 10% max. 6 minutes/hour.

Protection class: IP 66.

Insulation class: II, type B.

Alternating current: 

Direct current: 

Sound level < 45 dB.

Max. load: 170 kg – see identification label.

The bed is not provided with a mains switch, so the mains plug is the only separation from the mains.

The patient is not separated from the ground and the chassis.



Double insulated.



Max. load (SWL) (Patient + mattress + side rail + lifting pole + other equipment).

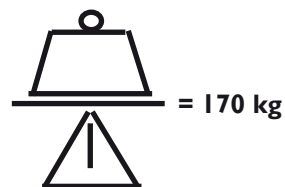

= 170 kg

The product should be reused where possible.



18. Weights

Mattress support 3-section	31,5 kg
Mattress support 4-section	35.0 kg
Top frame – head section 3-section.	18,5 kg
Top frame – head section 4-section.	18,5 kg
Top frame – leg section 3-section	13,0 kg
Top frame – leg section 4-section	16.5 kg
Base and shear arm.	28,5 kg
Base.	13,5 kg
Shear arm	15,0 kg
Bed ends Vibeke (per pcs.)	6,0 kg
Side rails Verso (per pcs.)	7,0 kg
Side rails Nina (per pcs.)	7,0 kg
Lifting pole.	7,0 kg



Yes, you can.®

Customer Sales and Service

Denmark

INVACARE A/S

Sdr. Ringvej 37
DK-2605 Brøndby
Phone: +45 36 90 00 00
Fax: +45 36 90 00 01
www.invacare.dk
denmark@invacare.com

Sweden & Finland

INVACARE AB

Fagerstagatan 9 / Box 66
S-163 91 Spånga
Phone: +46 8 761 70 90
Fax: +46 8 761 81 08
www.invacare.se
sweden@invacare.com

Norway & Iceland

INVACARE AS

Grensesvingen 9
Postbox 6230 Etterstad
N-0603 Oslo
Phone: +47 22 57 95 00
Fax: +47 22 57 95 01
www.invacare.no
norway@invacare.com

Spain

INVACARE S.A.

C/Areny S/N
Poligon Industrial de Celrà
E-17460 Celrà (Girona)
Phone: +34 972 49 32 00
Fax: +34 972 49 32 20
www.invacare.es
contactsp@invacare.com

Switzerland

MOBITEC REHAB AG

Benkenstrasse 260
CH-4108 Witterswil
Phone: +41 61 487 70 80
Fax: +41 61 487 70 81
switzerland@invacare.com

INVACARE France

Operation SAS

Ident. no.: 1441391

Version: 09

Date: 11.2008

Belgium & Luxemburg

INVACARE N.V.

Autobaan 22
B-8210 Loppem, Brügge
Phone: +32 50 83 10 10
Fax: +32 50 83 10 11
www.invacare.be
belgium@invacare.com

Netherlands

INVACARE B.V.

Celsiusstraat 46
NL-6716 BZ Ede
Phone: +31 318 695 757
Fax: +31 318 695 758
www.invacare.com
csede@invacare.com

Germany

INVACARE AQUATEC GmbH

Alemannenstrasse 10
D-88316 Isny
Phone: +49 75 62 7 00 0
Fax: +49 75 62 7 00 66
www.invacare-aquatec.com
info@invacare-aquatec.com

Portugal

INVACARE Lda

Rua Estrada Velha 949
P-4465-784 Leca do Balio
Phone: +351 225 1059 46/47
Fax: +351 225 1057 39
www.invacare.pt
portugal@invacare.com

Australia

INVACARE Australia Pty Ltd

1 Lenton Place, North Rocks
NSW 2151
Phone: +61 2 8839 5333
Fax: +61 2 8839 5353
www.invacare.com.au
sales@invacare.com.au

France

INVACARE Poirier S.A.S

Route de St. Roch
F-37230 Fondettes
Phone: +33 2 47 62 64 66
Fax: +33 2 47 42 12 24
www.invacare.fr
contactfr@invacare.com

Italy

INVACARE MECC SAN S.R.L.

Via dei Pini 62
I-36016 Thiene (VI)
Phone: +39 0445 38 00 59
Fax: +39 0445 38 00 34
www.invacare.it
italia@invacare.com

United Kingdom & Ireland

INVACARE LTD

South Road
Bridgend Industrial Estate
UK-Bridgend, CF31 3PY
Phone: +44 1 656 664 321
Fax: +44 1 656 667 532
www.invacare.co.uk
uk@invacare.com

New Zealand

INVACARE NZ

4 Westfield Place,
Mt. Wellington
Auckland
Phone: +64 9 917 3939
Fax: +64 9 917 3957
www.invacare.co.nz
sales@invacare.co.nz

Austria

MOBITEC MOBILITÄTSHILFEN GmbH

Herzog Odilostrasse 101
A-5310 Mondsee
Phone: +43 6232 5535 0
Fax: +43 6232 5535 4
www.mobitec-austria.com
austria@invacare.com



QUALITY SYSTEM

DS/EN ISO 9001
DS/EN ISO 13485

Manufacturer:

INVACARE France
Operation SAS

Route de St Roch
FR-37230 Fondettes
www.invacarebeds.dk