**'WE
MAKE
THINGS
FLOAT'**

CLM-1.5

Modular Levitation System

Manual

A TECHNOLOGY BY CREALEV

CONGRATULATIONS ON YOUR PURCHASE OF A LEVITATION MODULE FROM CREALEV!

Please take time to carefully read the instructions in this user manual. This will allow you to install and operate the levitation module correctly and will provide you with the full enjoyment of your purchase.

This manual contains important information about safety, use, limitations, warranty and technical support.

You are consequently strongly advised to read this user manual completely prior to using the levitation module.

By taking the levitation module in use, you accept the terms and conditions that are stated in the user manual concerning safety, use, warranty and technical support.

Tip: Keep this user manual for future reference.

CONTENTS

1)	GENERAL DESCRIPTION	03
2)	SAFETY AND PROTECTION	04
a.	General safety warnings	
b.	Overheating	
c.	Electromagnetic fields EMF	
d.	Power interruptions	
3)	USING THE LEVITATION UNIT	06
a.	Unpacking	
b.	Placing the base module	
c.	Setting up levitation system	
d.	Use of the carrier	
e.	Switching the levitation system off	
4)	CLEANING AND MAINTENANCE	09
a.	Cleaning	
b.	Storage	
c.	Replacement	
d.	Environment	
5)	WARRANTY AND SERVICE	09
6)	PRODUCT SPECIFICATIONS	10
7)	DECLARATION OF CONFORMITY	11
8)	COMPANY INFORMATION	12

1) GENERAL DESCRIPTION

The system is intended to levitate an object. The system can be used as stand-alone system, but can also be built into an other product or application.

The Crealev levitation system consists of 3 main parts.

1. There is an octagonal base unit with permanent magnets and electro magnets.
2. Carrier ring (carrying plateau) which contains permanent magnets.
3. The base is supplied with a power adaptor. The adaptor is customised for CLM 1.5.



Never use another adaptor than the adaptor supplied by Crealev!!

3. Adaptor

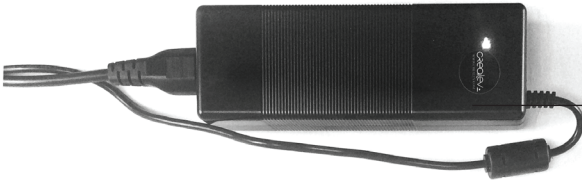

1. Base

2. Carrier

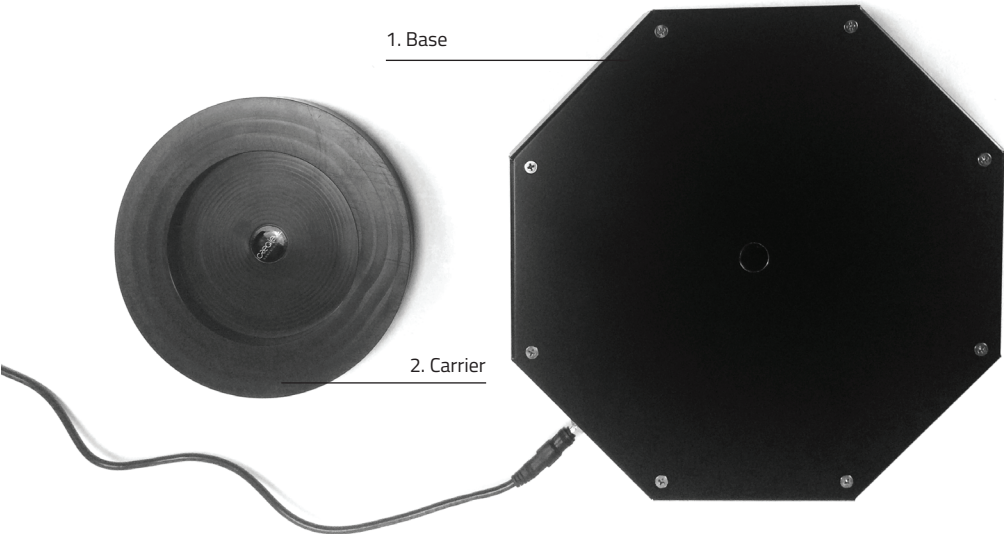

2) SAFETY AND PROTECTION

A. GENERAL WARNINGS

Please keep away from dangerous situations and refrain from creating dangerous situations like mentioned below:

Water and electricity are an extremely dangerous combination. Do not use this device in a humid environment (for example a bathroom or in the immediate vicinity of a shower, swimming pool or aquarium, etc).

Do not allow water or other liquids to enter or land on the device. The levitation module is not moisture-resistant.

Do not take the levitation module apart unless you are qualified to do so, to avoid the risk of electric shocks. Have maintenance and servicing carried out by qualified maintenance personnel. If you perform maintenance and service work yourself, the warranty will expire.



Naked flames or other heating objects such as candles or heaters must not be placed on top of or near to the levitation device.

Check that the voltage required by the appliance corresponds with the local mains voltage prior to connecting the appliance. The power adaptor is suitable for voltages from 100V to 240V. The powerplug connected to the adaptor is EU two pins standard.

The mains supply works with a safety transformer, power adaptor. Replace this, if it is defective, with a new one which you can order from Crealev.

Do not damage the power cable and avoid using the cable in winded position.

Never try to remove the rubber cover at the bottom of the carrier ring

This levitation module is not intended for use by persons (including children) with physical, sensory or mental disabilities, or with a lack of knowledge or experience, unless someone who is responsible for their safety supervises them or has explained to them how the levitation module should be operated.

Supervise children to prevent them from playing with the levitation module.

Situate the levitation module on a stable, level surface and ensure that there is at least 20 cm free space around the device and 40 cm above the device to prevent overheating.

Never move the levitation module during use.

Do not use the levitation module at temperatures lower than -10 degrees Celsius or higher than 35 degrees Celsius.

Ensure that ventilation openings remain open during use.



Allow the levitation module to cool off for 15 minutes before cleaning or storing.

Never use the levitation module if it is damaged or broken, or if a part is missing as indicated in the 'general description'.

The levitation unit does not have an on/off switch. If you would like to disengage the appliance from the mains supply, remove the plug from the socket. But before doing so, first remove the carrier ring from it's levitation position.



B. OVERHEATING

The levitation module is equipped with an automatic overheating trip. If the appliance is insufficiently cooled, the device switches off automatically.

If the levitation module is overloaded or if the base has too much excitation, due to imbalance, irregular turning or other overburdening, the base can heat up and thermal protection will shut the device down.

Temperatures:

The specified data apply when the module is placed on top of a table.

When the module is built into a 'casing' the characteristics may differ.

Maximum operating temperature	35 [deg C]
Minimum operating temperature	-10[deg C]
Temperature rise base at no excitation	10[deg C]
Thermal shutdown case temperature	≈55[deg C]

If the safety overheating protection shuts the device down, the carrier ring will fall down on the base module. Please be aware of potential danger considering the load on the carrier ring.

If this happens, remove the cause of the overheating, remove the plug from the mains socket and allow the base module to cool off for approximately 15 minutes. Then re-insert the plug into the socket.



C. ELECTROMAGNETIC FIELDS (EMF)

Guidelines for magnetic sensitive objects:

Due to the presence of magnets in the module and carrier, the module generates a magnetic field. This could be interfering with magnetic sensitive objects like a creditcard, pacemaker or memory hardware like floppy disks and harddrives.

A distance of 10 cm (4 inch) is advised.

Technical Note:

Approximately 300 Gauss of magnetic field strength is safe for magnetic stripe devices like credit cards. The stray field at 10 cm (4 inch) distance is less than 100 [Gauss].

This levitation module complies with all the guidelines for electromagnetic fields (EMF). Providing the levitation module is used correctly and according to the instructions in this user manual, it is safe for use according to the now available scientific evidence.

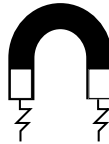

ALWAYS UNPLUG
BASE WHEN CARRIER IS
NOT IN FLOATING
POSITION TO AVOID
OVERHEATING!

D. POWER INTERRUPTION

In the event that the power is interrupted, the carrier ring will land near the levitation unit with force. This occurs with a slap, but does not have a negative effect on the operation of the levitation unit. If this occurs, 'pull' off the carrier ring from the base module, restore power, and repeat the instructions 'How to set up the levitation system' from step 3.

3) USING THE LEVITATION UNIT

A. UNPACKING

When you unpack the device, please keep the carrier ring away from metal objects and objects that are sensitive to magnetism, for example bank cards and memory hardware like floppy disks and harddrives.



Be careful with the carrier ring around magnetic sensitive objects or magnetic sensitive surfaces (iron). They will be attracted to each other. There is a great risk, that by trying to remove the parts, damage may occur.

Warning: never position two or more carrier rings near to each other, they attract each other with a great force, with the risk of physical injury such as trapping, bruising or worse!

B. PLACING THE BASE MODULE

The base module should be mounted horizontally on a flat and sturdy surface, preferred accuracy better than 2°.

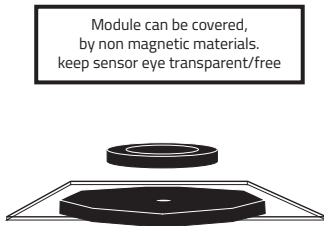

BOTTOM OF BASE MODULE:

Preferably the bottom should be open, in order to let air flow along the bottom of the unit. This is to prevent overheating of the base in case of excitation.

TOP OF BASE MODULE:

The top can be covered with a thin sheet of any non-magnetic material, of a few millimeters thick.

The black center section on the base, the sensor, should always be left open. So any non transparent covering sheet should have an opening above the sensor.

The top could be covered by a full glass sheet or other transparent sheet material of preferably 2 mm thickness (max 3 mm).

The transparent sheet should be in direct contact with the top of the base module. The center section should always be fully transparent.

Avoid bright (sun) light on the sensor (black central part).

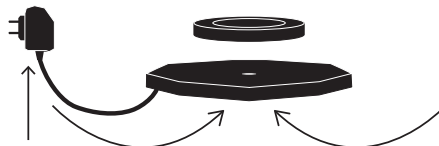
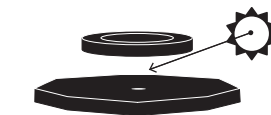
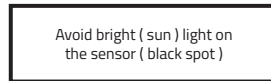

C. HOW TO SET UP THE LEVITATION SYSTEM

1. Place base module (regarding all previous mentioned requirements)
2. Connect the mains plug to the mains power supply (max 230V). (Sufficient air flow along the power adapter is necessary.) Make sure all three red lights of the poweradaptors are burning. If not, please check if the plugs are correctly inserted into the poweradaptors.
3. In the middle of the carrier ring, there is a reflective spot. Please hold the reflective spot in the middle of the carrier ring, 8-10 cm directly above the sensor. You should now feel the repelling action of the permanent magnets in the carrier and in the levitation unit.
4. Once you feel the levitation unit coming online, the carrier ring 'locks' itself into position. The carrier ring will now be held in position by the electromagnetic field and the control system.
5. Carefully release of the carrier ring.



WARNINGS!

The carrier is held in place by an optical sensor. Therefore one must not put anything between the sensor of the base and the reflective spot of the carrier. Otherwise the carrier will fall down.

If you build the base module into an object, make sure that 'casing' does not obstruct the optical system and that there is enough airflow nearby the ventilation openings.

The electromagnetic field works in vertical direction. The carrier can be horizontally pushed or knocked out of balance and out of the electromagnetic field. If this happens, the carrier ring will fall down.

If the carrier ring falls down, it will land on or near base module with great force and with a slap. This situation should be avoided but this does not have a negative effect on the operation of the levitation unit.

If this occurs, please 'pull' off the carrier ring from the base module and repeat the instructions from step 3.

If a burden or load is placed on the carrier ring, make sure this can't become damaged or create a dangerous situation when the carrier ring falls down.

Only use the power supply provided by Crealev.

D. USE OF THE CARRIER RING AND LOADING

The carrier could be 'wrapped' or 'built in' other materials and objects. Please keep in mind that the reflective spot at the center bottom must be visible. So the 'casing' or load should not obstruct the center bottom of the carrier.

Always keep a matted (non glossy or reflective) circular area, with a diameter of 6 cm, around the reflective spot

Watch out, the carrier is permanently magnetic. It attracts iron and magnetic parts. It could influence objects that are vulnerable to magnetic fields.

If the 'casing' or the load of the carrier ring contains iron or other magnetic parts; it may influence and disturb the levitation.

The heavier the load or 'casing'; the lower the levitation height.

The heavier the load; the more attention has to be paid to balancing the carrier with that load.

The heavier the load, the closer the weight should be to the carrier surface. The center of gravity should be as low as possible and centered as well possible. Avoid large or heavy weights sticking out far above the carrier surface.

Improper balancing can result in irregular rotation of the carrier and possible heating up of the base module.

Extreme irregular rotation could result in the carrier falling down.

When a load is placed on top of the carrier, the center of that load (center of gravity) should not be placed too high. If the load is placed too high the carrier and load might tip over. The numbers below give the maximum height of the center of gravity of that load.

When a load is placed on top of the carrier, the center of that load (center of gravity) should not be placed too high. If the load is placed too high the carrier and load might tip over. The numbers below give the maximum height of the center of gravity of that load.

Height limitations of the load (product):

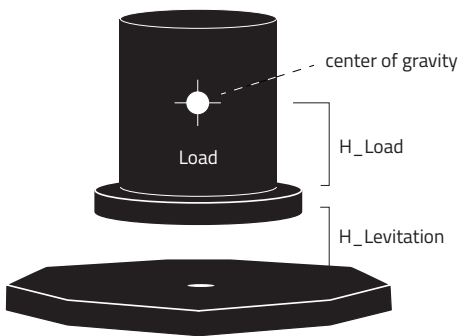

Crealev strongly advises to keep non-authorized persons away from the levitated carrier, a distance of 1 meter is recommended. Touching the levitated carrier or blocking of the sensor eye on the module may cause the carrier to fall down and can possibly cause injury or damage.



Crealev recommends the placement of a protective casing like for example a transparent tube around the levitation system (crosssection transparent tube 45 cm).

E. SWITCHING THE LEVITATION SYSTEM OFF

If the carrier ring is in the levitating (floating) position, carefully remove the carrier ring with its load from the position and place it away from any metal or magnetic objects.

Pull the power plug out of the mains socket.

Allow the levitation module to cool off for 15 minutes before cleaning or storing.

When the levitation device is stored, place the carrier ring on the base module with a 5 cm foam layer in between.

Maximum load location on top of carrier ring:

Load = 0 kg	H_load = -	H_levitation = 71 mm
Load = 1 kg	H_load = 190 mm	H_levitation = 52 mm
Load = 2 kg	H_load = 130 mm	H_levitation = 43 mm
Load = 3 kg	H_load = 105 mm	H_levitation = 35 mm
Load = 4 kg	H_load = 90 mm	H_levitation = 28 mm

4) CLEANING AND MAINTENANCE

A. CLEANING

Always remove the plug from the mains socket and allow the levitation module to cool for approximately 15 minutes before you clean it.

Never use abrasive sponges, abrasive cleaning agents or aggressive solvents such as white spirit or acetone for cleaning the levitation module.

Remove dust from the appliance regularly, especially from the optical sensor in the centre, using a dry cloth, because dust can have a negative effect on the operation of the levitation technology.

Clean the exterior of the levitation module with a clean damp cloth.

Do not allow any water or other liquids to enter or land on the base module.

B. STORAGE

Please store the levitation module, preferably in the packaging or protective wrappings.

Please store the levitation module in a dry safe place without extreme temperature changes.

When the levitation device is stored, place the carrier ring on the base module with a 5 cm foam layer in between.

C. REPLACEMENTS

In case of malfunction or defects the levitation module can be returned to Crealev for possible adjustment or repair.

D. ENVIRONMENT

Do not dispose of this device at the end of its lifecycle with the rest of the normal household refuse.

Preferably deposit it at one of the government-indicated collection points so that it can be recycled. In doing so, you will be contributing to a cleaner living environment.

5) WARRANTY AND SERVICE

If you require service or information or if you have a problem, please visit website www.crealev.com or If your country does not have a distributor, please approach your dealer or contact the Crealev service department at crealev@crealev.com

There is a 1-year international warranty on all parts. Shipment costs are for the buyer. Repair and replacement costs within period of warranty are on behalf of Crealev BV. The warranty expires if the device has been altered by others.

Due to liability insurance, Crealev BV does not sell levitation modules to buyers who are based in Northern American countries, unless they sign Crealev's 'Release and Indemnity' form.

Hereby any buyers, resellers or users located in the US or Canada take full responsibility for any irregularities/ damage or negative effects that may occur while using the Crealev Levitation Module.

For any other service, questions or information, please contact Crealev crealev@crealev.com.



6) PRODUCT SPECIFICATIONS

- Rated input voltage 110-240V
- Rated frequency 50-60Hz
- Rated input 90 Watt
- Rated output 90 Watt / 19 V / 6 Amp
- Class III (only suitable for low voltage 19V)
- Classification none
- Water penetration IP x 0
- Conditions for use temp: from -10°C to +35°C
- Relative humidity: from 30% to 90%
- Storing conditions temp: from -20°C to +50°C (no condensation)

You must take measures to prevent electromagnetic faults or other faults between this device and other appliances.

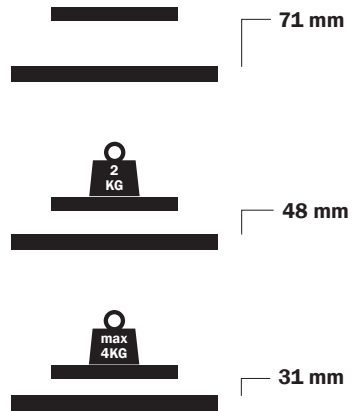
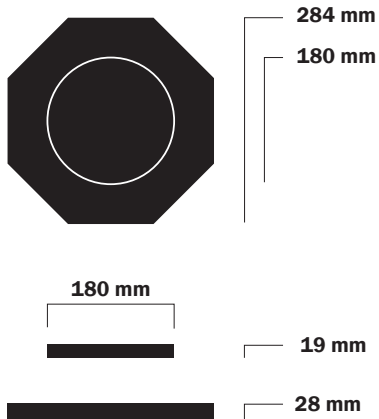

7) DECLARATION OF CONFORMITY

We,

Crealev BV
Klokgebouw 177
5617 AB EINDHOVEN
Netherlands

declare under our sole responsibility that the product as originally delivered,

Name: Levitation module
Type: CLM-2

Function: The CLM-2 is a universal module that is able to levitate objects all kinds of objects. The modules consist of a base above which a magnetic disc floats. This magnetic disc serves as floatation plateau for objects. As well the base as the floatation disc can be integrated in products. The disc will be integrated in the floating part of that product. The base contains electronic elements for stabilization of the levitation system. The disc does not contain any electronics, it contains only passive permanent magnets.

complies with the essential requirements of the following European Directives, and carries the CE marking accordingly:

Low voltage directive: EN 2006/95/EC
EMC directive: EN 2004/108/EC
RoHS directive: EN 2002/95/EC

and conforms with the following harmonized European standards:

EN 60204-1: 2006 Electrical safety, part 1
EN 61000-6-1: 2007 EMC, Immunity, part 6-1
EN 61000-6-3: 2007 EMC, Emission, part 6-3
EN 14121-1 Risk analysis
NEN 5509 Design for user manuals

Eindhoven, The Netherlands
Date: 20-3-2011

Ger Jansen
Director Crealev BV
Signature:



A handwritten signature in black ink, appearing to be 'Ger Jansen', written over a light blue horizontal line.

8) COMPANY INFORMATION



Crealev BV

Klokgebouw 177
5617 AB Eindhoven
The Netherlands

T +31 (0)40 8519 040
E www.crealev.com

General support:
crealev@crealev.com

Technical support:
info@crealev.com

Chamber of Commerce number :
NL 17198991 Eindhoven,
The Netherlands

crealev.
LEVITATION TECHNOLOGY

www.crealev.com

join us on facebook  watch us on youtube 