



USER MANUAL

LED PAR64 [®]

(PAR64-F1018: 18*10W,RGBAW 5-in-1)



Catalogue

summarization.....	1
safety instruction.....	1
outside size picture.....	2
main function.....	3
DMX control function.....	3
Display operation instruction.....	4
Menu instruction.....	5
Operating control instruction.....	8
XLR connection instruction.....	8
Connecting picture.....	9
Trouble shooting.....	9
Technical specification.....	11

Please read over this manual before operating the light

1. Summarization

➤ **Summarization**

Thank you for purchasing our LED PAR64 lighting. Please read these instructions carefully before begin and operate the fixtures according to these instructions to avoid any possible damages and accidents causes by misuseage.

➤ **Products introduction**

LED PAR64 light uses aluminum shell. It adopts high power 5-in-1 LED, which refers to single LED is made of R,G,B,A,W LED, And long life span, low consumption, good color mixing effect and high brightness are the most prominent features. Each kind of LED can be independently dimmed. The built-in program includes dimming, strobe, eotic, gradual change, fading and so on. It uses power switch, performs low weight and consumption, stable capability and long life. International standard DMX 512 signal is requested.

➤ **Packing list**

- LED PAR64 light 1PC
- DMX signal cable 1PC
- The User Manual
- Warranty Card

2. Safety Instruction

➤ **Safety Notes**

! Enquire the skilled people before any repair;

! Always make sure disconnect from the power source before setting up, serving and moving;.

! Avoid direct eye exposure to the fixture when it is on;



➤ **Safety instruction**

- Make sure the power supply voltage are consistent with this lights , Ensure the use of voltage is in the range of the request technical parameter.
- Before the installation, please check the light's fasteners and mechanical structure have been received in good condition and appear no damage.
- This light is designed for indoor use; working temperature is lower than 50 degree.
- The fixtures maybe mounted in any position provided there is adequate room for ventilation. Make sure there are no inflammable and explosive items (ornaments) in 0.5 meters away.
- Yellow / green cabling earthing safety; no flicker when the fixture is working on.

3. outside Size Picture

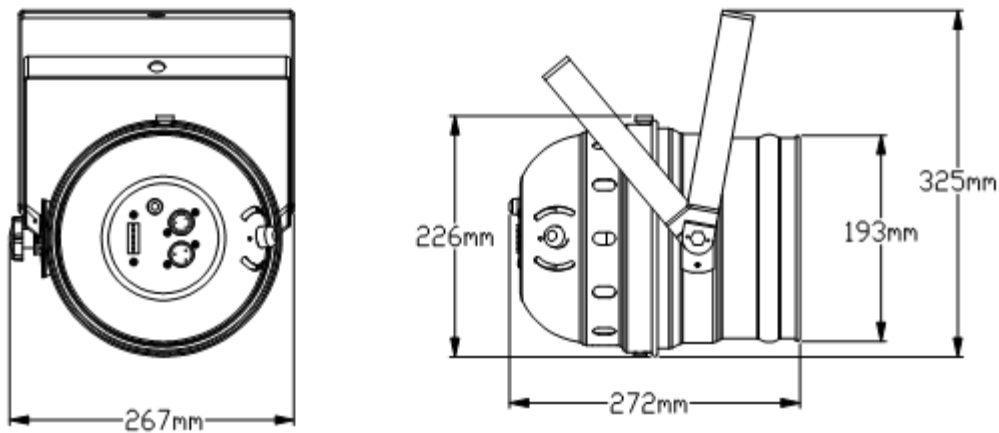

LED PAR64 (short can)

4. Main Function

- high quality LED: low consumption, brightness, stable capability and long life
- each color of LED with 16666 grades dimming. The refreshing rate is above 400Hz.
Flicker free
- RGBAW color mixing, good saturation
- dim 0%-100%, Strobe、gradual change、jumping change
- DMX512 Controller, 4 button set DMX ID address with led display
- auto run /sound activated/master slave/interconnected multi-machine control
- using switching power supply to protect the LED to work well
- lens degree: 25°、45°、60° optional
- DMX control channel optional

5. DMX Control Function

- DMX Channel (4CH)

Channel	DMX Value	Control Function	Remarks
1CH	0-255	RGB color mixing	Hue
2CH	0-255	A Dimming 0-100%	
3CH	0-255	W Dimming 0-100%	Color Saturation
4CH	0-255	General dimming 0-100%	purity

- DMX Channel (5CH)

Channel	DMX Value	Control Function	Remarks
1CH	0-255	R 0-100%	
2CH	0-255	G 0-100%	
3CH	0-255	B 0-100%	
4CH	0-255	A 0-100%	
5CH	0-255	W 0-100%	

- DMX Channel (9CH)

Channel	DMX Value	Control Function	Remarks	Priority
1CH	0-255	(General		1

		dimming)		
2CH	0-255	Red dimming 0—100%		
3CH	0-255	Green dimming 0—100%		
4CH	0-255	Blue dimming 0—100%		
5CH	0-255	Amber dimming 0—100%		
6CH	0-255	White 0—100%		
7CH	0-14	Dimming		2
	15-255	Strobe Speed		
8CH	0-31	Invalid	32-127, Must use CH1,2,3,4,5CH, otherwise no light. From the 9CH, start the speed adjustment.	3
	32-63	From dark to bright		
	64-95	From bright to dark		
	96-127	From dark—bright—dark		
	128-164	RGB Gradient		
	165-191	dark—bright—dark auto run		
	192-223	Multi-colors jumping change		
224-255	Sound control			
9CH	0-255	Speed Adjustment, slow-fast		

➤ DMX Channel (10CH)

Channel	DMX Value	Control Function	Remarks	Priority
1CH	0-255	(General dimming)		1
2CH	0-255	Red dimming 0—100%		
3CH	0-255	Green dimming 0—100%		
4CH	0-255	Blue dimming 0—100%		
5CH	0-255	Amber dimming 0—100%		
6CH	0-255	White 0—100%		
7CH	0-14	Dimming		2
	15-255	Strobe Speed		
	0-31	Invalid	32-127, Must use	3
	32-63	From dark to bright		

8CH	64-95	From bright to dark	CH1,2,3,4,5CH, otherwise no light. From the 9CH, start the speed adjustment.
	96-127	From dark—bright—dark	
	128-164	RGB Gradient	
	165-191	dark—bright—dark auto run	
	192-223	Multi colors jumping change	
	224-255	Sound control	
9CH	0-255	Speed Adjustment, slow-fast	
10CH	0-5 6-55 56-105 106-155 156-205 206-255	Set by LED display DIMMER0 DIMMER1 DIMMER2 DIMMER3 DIMMER4	



6. Display Operation

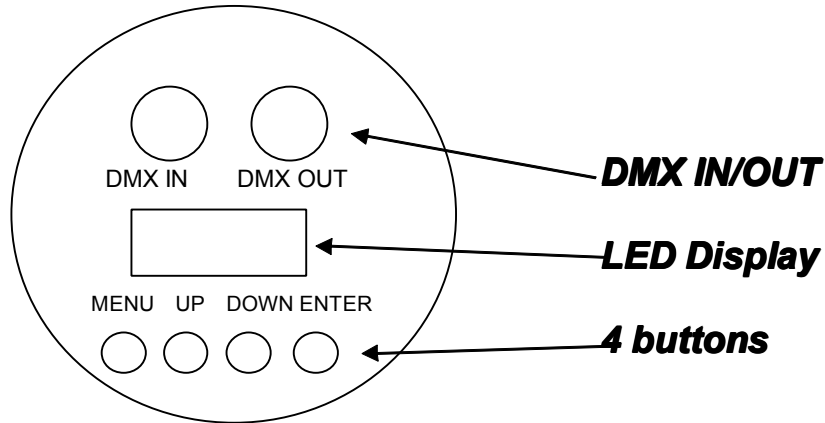

- MENU : access the menu or return to a previous menu option
- ENTER: select the current menu option
- UP: menu selection or parameter increments
- DOWN: menu selection or parameters decrease

7. Menu Instruction

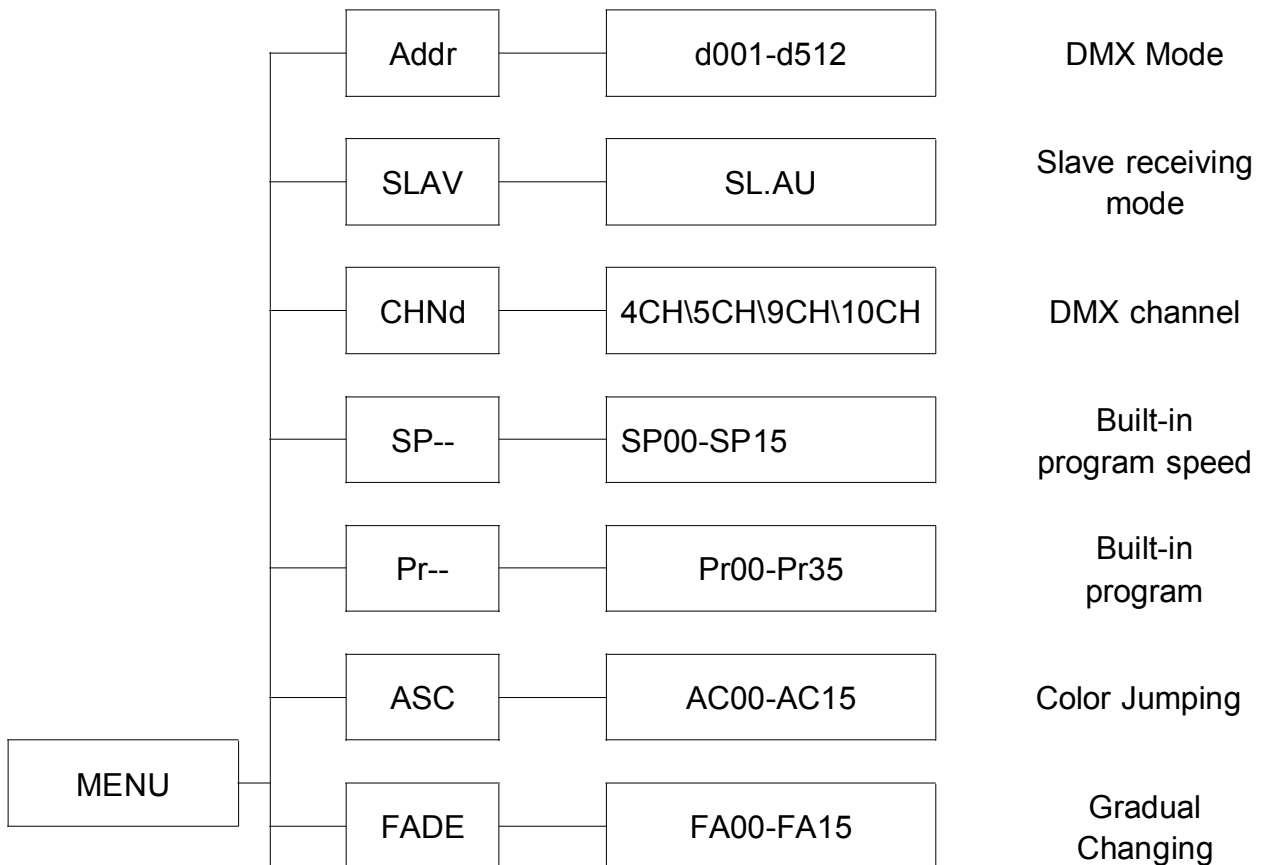

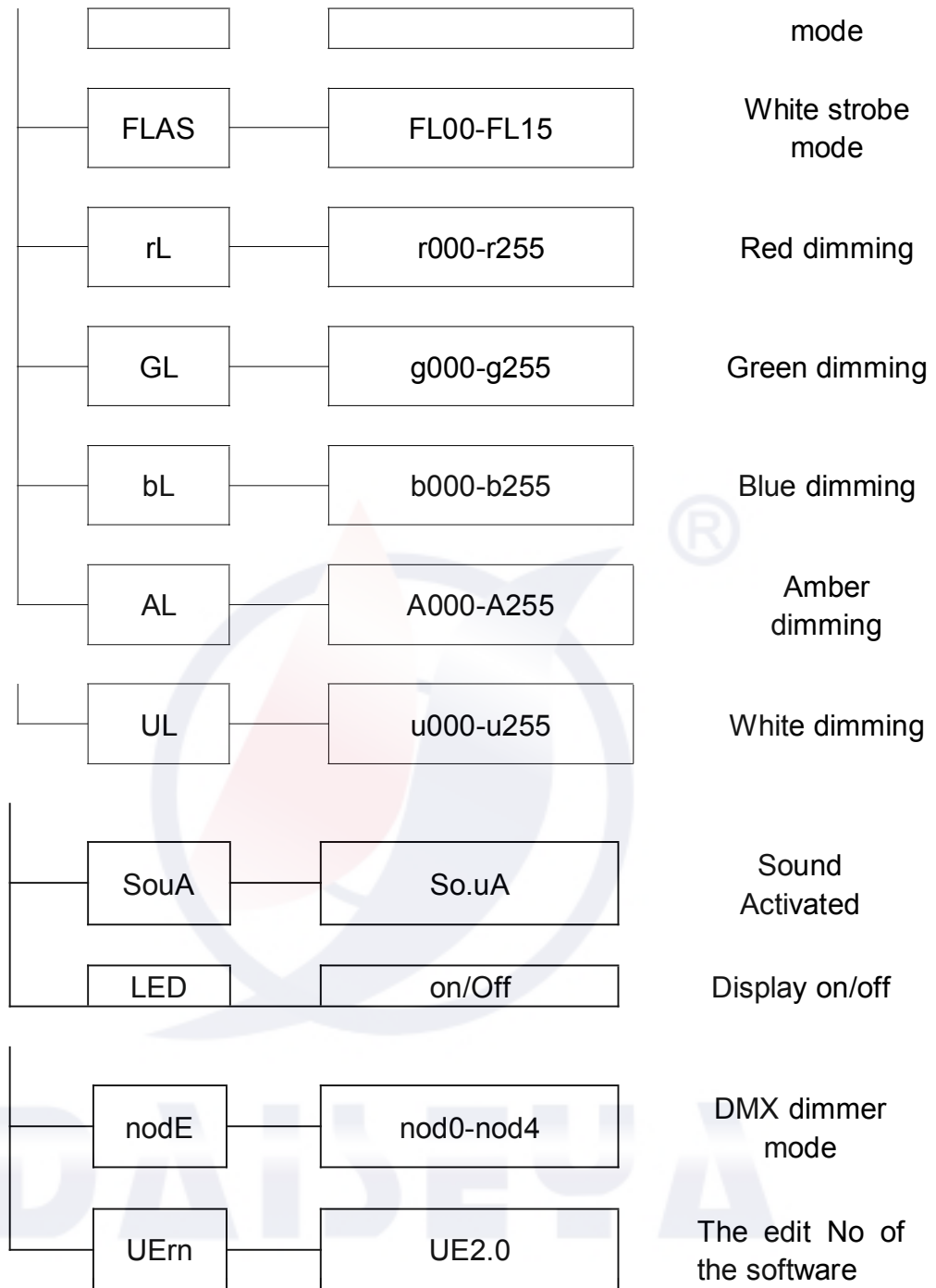

Operating instruction:



MENU (UP/DOWN) +ENTER+UP/DOWN) +ENTER

Remark: Exp: Select the DMX mode, Here are the operation details:

- Press the MENU, go back to the initial setting
- Press UP/DOWN, display “Addr”

- Press ENTER to change the content, the display will flash at this moment
- Press UP/DOWN to change the address code to select d001
- Press ENTER to select and store the current menu options. DMX mode will be

stored automatically and the screen will stop flashing.

Exp: Select DMX Channels optional mode, the operation is as below:

- Press MENU, go back to the initial setting
- Press UP/DOWN, display "CHnd"
- Press ENTER to change the content, the display will glinting at this moment
- Press UP/DOWN to select the DMX channels that you need, 3CH、4CH、5CH and so on
- Press ENTER for 10 seconds to select and store the current menu options. DMX channel will be

stored automatically and the screen will stop glinting.

Exp: turn off the display, the operation is as below:

- Press MENU, go back to the initial setting
- Press UP/DOWN, display "LED"
- Press ENTER to change the content, the display will flash at this moment
- Press UP/DOWN to select "OFF"
- Press ENTER to confirm, then select the working mode that you need. When stop pressing, the display will turn off after a while. When the display is off, press any button to activate the display. If setting the led to "off", when stop pressing, the display will turn off after a while.

2、Details of program built inside (Pr- -)

Press MENU, go back to the initial setting

- Press UP / DOWN until Pr--
- Press ENTER to choose, the display will flash at this moment
- Press UP / DOWN to change the address code to select pr00
- Press ENTER to select and store the current menu options. DMX mode will be

stored automatically and the screen will stop flashing.

Remark: Pr32--- Pr35 Can change the content Of SP , correct the speed of jumping change , SP00 is the fastest, SP15 is the slowest

- Pr00-Pr31: R,G,B,A,W single color or multi-colors mixing
- Pr32: 5 colors jumping change
- Pr33: 5 colors jumping change +strobe
- Pr34: multiple colors jumping change
- Pr35: multiple colors jumping change +strobe

8. Operating Control Instruction

➤ **Master/Slave**

Master: The master should always work as a master as long as it is not set in a DMX mode whatever other modes it is. And it send out the signal so that the slave synchronous with it. To avoid the host signal and DMX512 signals interfere with each other, should cut off the DMX512 signals. The signal lines are longer than 60 meters, should increase a signal amplifier.

Slave: the Slave must be set in DMX mode and the address code should be A001, to assure receive the master's signals correctly. Only one light can be set as a Master and others are slaves.

9. XLR cable connecting

➤ **XLR cable:**

The standard way of connecting the XLR is: one end connects to the male plug, and the other end connects to the female. As bellow: pin 1: ground, pin 2: negative signal, pin 3: positive signal

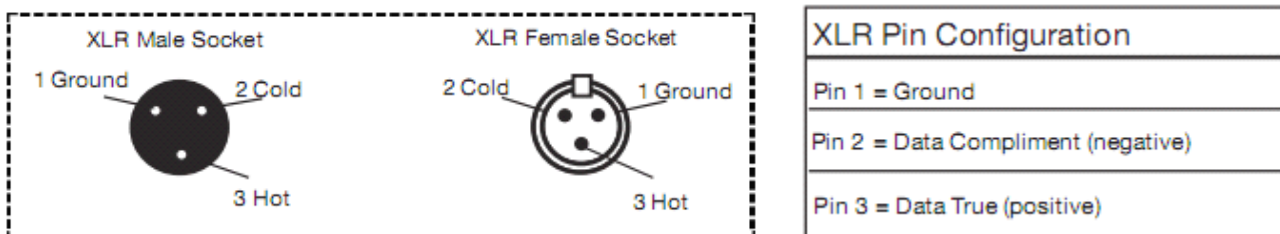

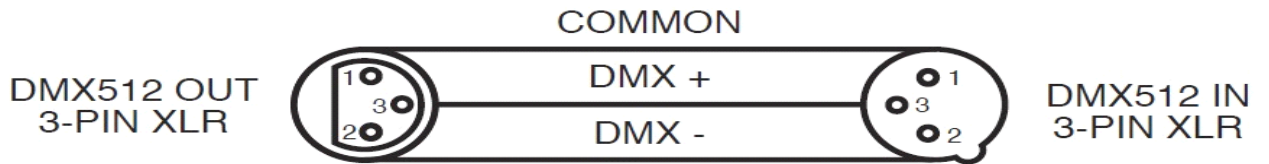

Noted: In order to avoid failures and interference signal transmission, we connect a resistance 120Ω (1/4W) at the end of the DMX connecting as below:



Termination reduces signal errors and avoids signal transmission problems and interference. It is always advisable to connect a DMX terminal, (Resistance 120 Ohm 1/4 W) between PIN 2 (DMX-) and PIN 3 (DMX +) of the last fixture.

- The Conversion between 3 pin and 5 pin XLR

If the output cable of DMX512 controller is the 5PIN, please use 1pc 5PIN to 3PIN cable

3-Pin XLR to 5-Pin XLR Conversion		
Conductor	3-Pin XLR Female (Out)	5-Pin XLR Male (In)
Ground/Shield	Pin 1	Pin 1
Data Compliment (- signal)	Pin 2	Pin 2
Data True (+ signal)	Pin 3	Pin 3
Not Used		Do Not Use
Not Used		Do Not Use

10.Connecting picture

- Light connecting picture:

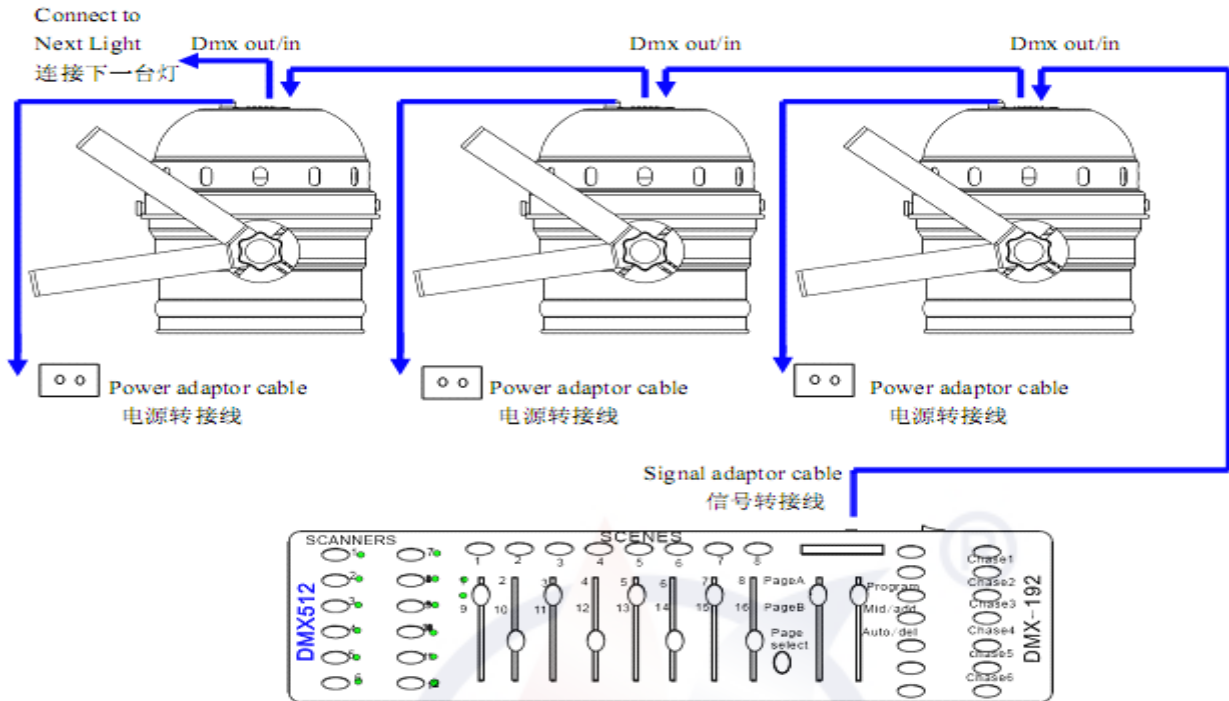

11. Trouble Shooting

Problem	Checking Way
Can not turn on the light	<ul style="list-style-type: none"> ◆ Check the power source plug is in normal or not ◆ Check the switch of the lights is off or on ◆ Check the fuse if in normal
DMX can not control it	<ul style="list-style-type: none"> ◆ Check the DMX cable is connect to the lights or not ◆ Check the DMX512 controller work in normal or not ◆ Check the DMX cable is normal or not ◆ Check if the lights is in DMX mode (A001)
Display not bright	<ul style="list-style-type: none"> ◆ When connect to the electricity, did the led flash one time? If so, the power source is normal; If not, please check if the switch and the transformer has power out ◆ Check if the power input of the IC board is normal

	<ul style="list-style-type: none"> ◆ Check if the cable connect to the display loose ◆ Change the main board to see if it is normal. ◆ Chang the display
LED not light	<ul style="list-style-type: none"> ◆ When connect to the electricity, did the led flash one time? If so, the power source is normal; If not, please check if the switch and the transformer has power out ◆ Check if the power input of the IC board is normal ◆ Check if the cable connect to the display loose ◆ Change the main board to see if it is normal. ◆ Chang the display
Some of the LED not light	<ul style="list-style-type: none"> ◆ LED is connected by leds in series first, then connect parallel, so please check if the leds is loose ◆ Use the multimeter to check if the led is bright or not, of not, please change the led ◆ check whether current limiting resistor is normal or not ◆ Check constant current IC is normal or not (compared with the normal IC)
Single color leds always bright/not bright	<ul style="list-style-type: none"> ◆ Check the switch of this color is normal or not ◆ Change the IC control board

Noted: only professional persons can do as above !

12. Technical Specification

- Input voltage: AC 100V-264V/47-63HZ
- Output voltage:DC24V
- Consume:180W
- Lamp Type: High Power LED(10W)
- Lamp Spec:5-in-1 10W (18PCS)

- Constant current driver:500MA
- PWM Dimmer: » 400HZ(16666 steps)
- Life span: 50000hours
- Control Signal: DMX512, sound activated, auto run
- Control mode: stand alone/ sound activated
- Channel: 4CH、5CH、9CH、10CH
- Color effect: RGBAW mixing
- Function Effect: dimmer, strobe, eotic, gradual change, sound activated
- Beam Angle: 25°,45°,60°
- Cooling mode: fan cooling
- Anti-electricity intension: 1.5KV
- Insulation Resistance:> 2 MΩ
- Size: 220*270*350mm
- Net Weight:3.5KG

