

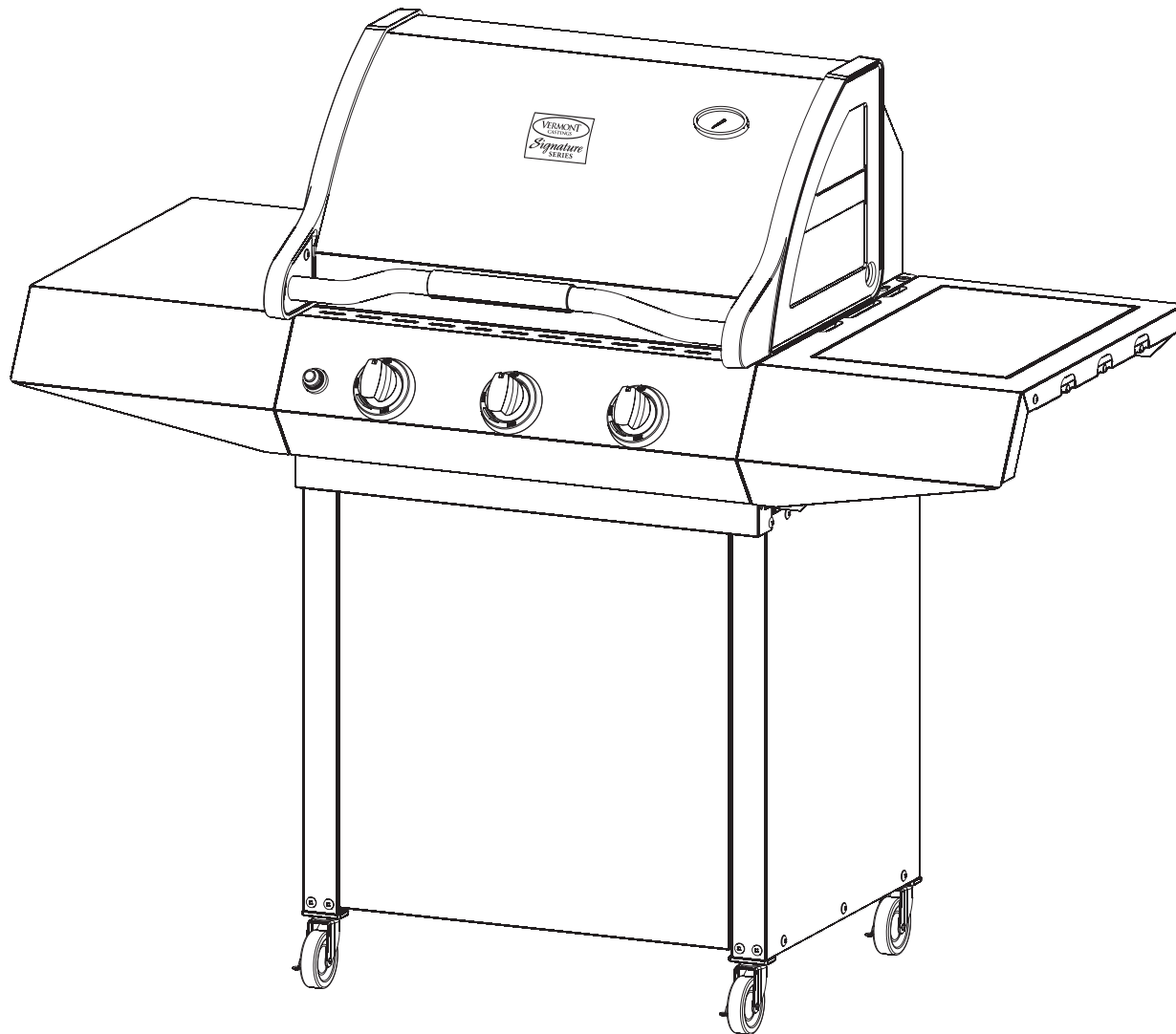

VCS3507 / VCS3517 ASSEMBLY PROCEDURES

Tools Required: knife or scissors, #2 and #3 Phillips or Robertson (square head) screwdriver, 7/16" and 3/8" wrench or ratchet, hammer, flat head screwdriver.



Step 1: Unpack Carton and Verify Contents

Use a sharp cutting tool to cut the straps on the packaging and then open the carton top. The sleeve surrounding the barbecue can be removed by lifting it straight up and over the top of the unit. Unpack all parts and compare all contents to the parts list that accompanies this assembly manual. Next, remove the protective plastic coverings from the metal parts. Be careful not to scratch or damage the finish of the metal parts when removing the protective plastic. Refer to the parts list for fastener detail.

CAUTION: Some parts may have sharp edges; to avoid injury, wearing gloves during assembly is strongly recommended

Step 2: Attach the Caster Inserts to the Cabinet sides

Parts Required:

- (2) Cabinet Sides
- (4) Caster Inserts

Insert one (1) Caster Insert into both bottom corners of the cabinet end and ensure they are fully pushed in and engaged.

Next: Repeat this step for the opposite Cabinet Side.

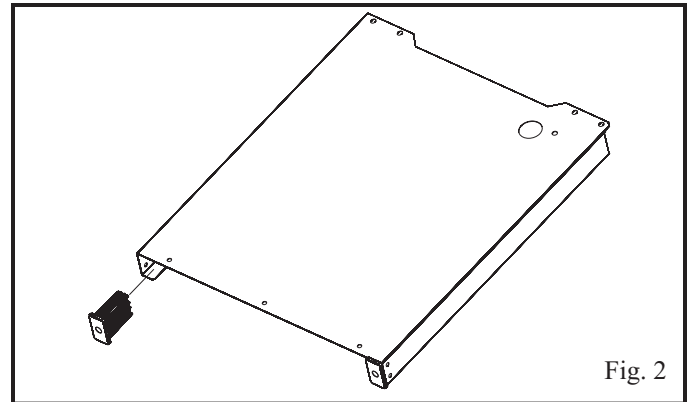

Fig. 2

Step 3: Attach the Cabinet Sides to the Bottom Panel

Parts Required:

- (1) Bottom Panel
- (2) Cabinet Sides with Caster Inserts attached
- (6) 1/4-20 x 1/2" Bolts
- (8) 1/4-20 x 1-1/2" Bolts
- (14) 1/4-20 Nuts

A. Position the Bottom Panel and Cabinet Sides as shown in Fig. 3a, and align the holes of the Bottom Panel with the holes in the Cabinet Side.

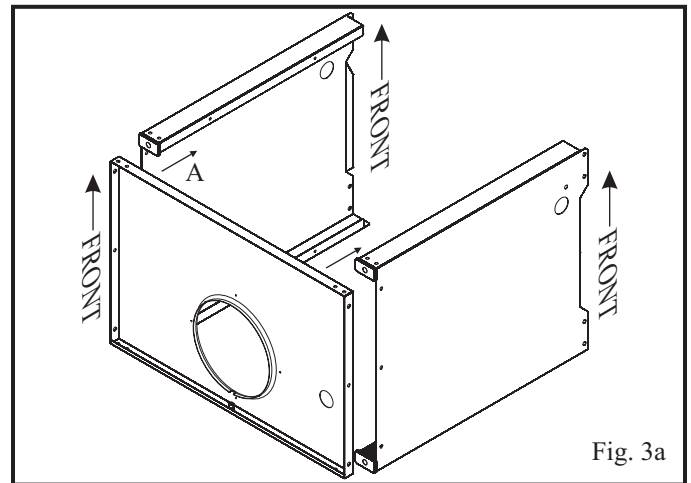

Fig. 3a

B. Insert a 1/4-20 x 1/2" Bolt through each of the side holes of the Cabinet Sides and tighten using 1/4-20 nuts for each. (3 bolts per side)

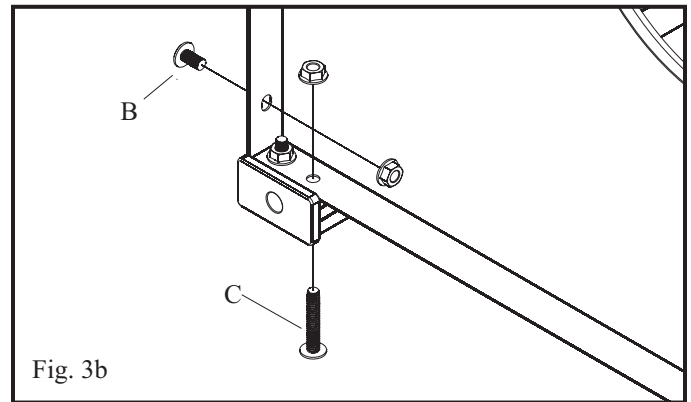

Fig. 3b

C. For each bottom corner of the cabinet assembly, insert two (2) 1/4-20 x 1-1/2" bolts all the way through the end holes of the Cabinet Side and through the Caster Insert, then tighten using (1) 1/4-20 nuts for each.

Step 4: Install the Casters

Parts Required: (4) Casters

Insert the stem of the Caster as far as possible into the bottom of each Caster Insert. Ensure the Casters are locked by pushing the locking tabs into the "down" position.

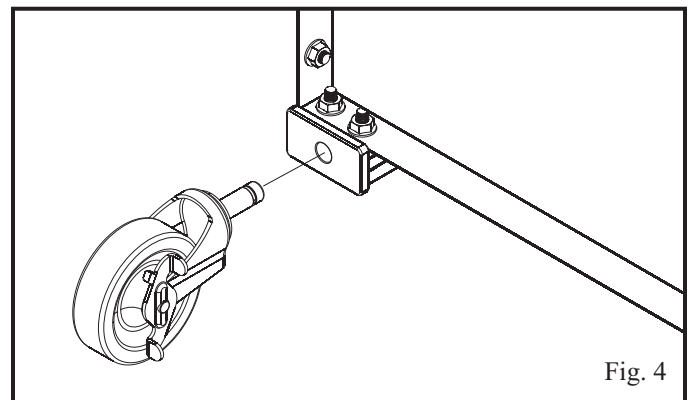

Fig. 4

Step 5: Install the Front Panel

Parts Required:

- (1) Front Panel
- (4) #10-24 x 1/2" Bolts
- (4) #10-24 Lock Nuts

Note: Before you install the Front Panel, ensure the bottom panel is positioned so the hole for the LP cylinder is towards the back and the smaller Knock-Out Hole is to the right of the cylinder hole.

Note: Be sure to remove all protective plastic coating from stainless steel parts.

Align the holes on the side of the front panel with the holes on the cabinet side, making sure that the lighting instructions on the front panel are right side up. Next, insert two (2) #10-24 x 1/2" Bolts through the side of the front panel and cabinet side (Fig. 5b). Ensure the front of the panel is flush with the front of the cabinet side and screw on #10-24 Lock Nuts to secure the front panel in place.

Repeat this step for the opposite side of the panel.

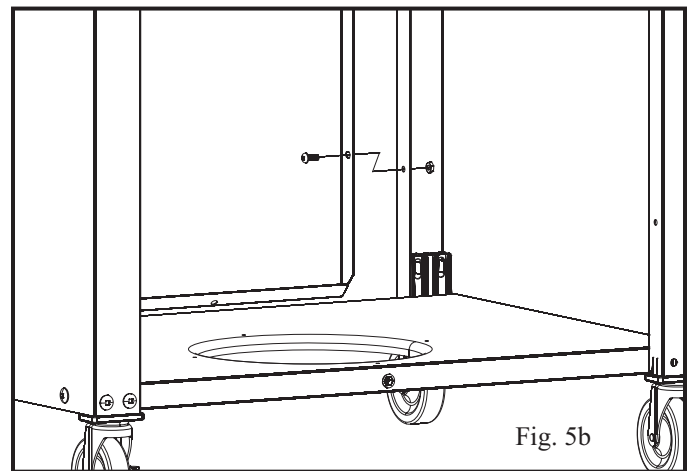
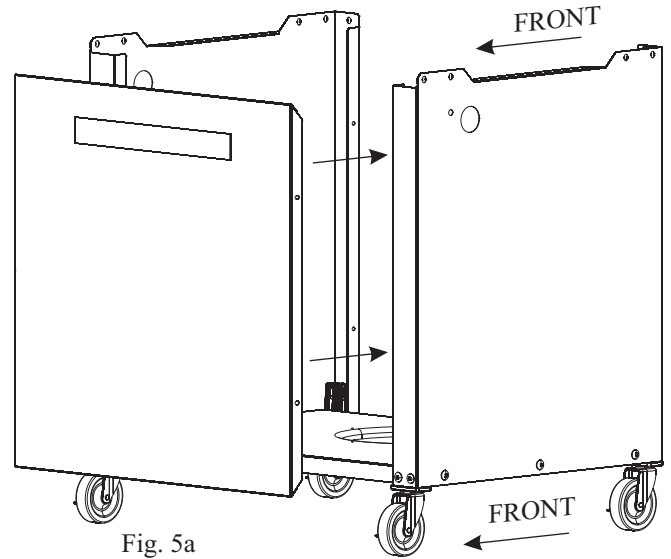

Step 6: Attach U-Clips to Base Ends and Insert Side Shelf Bolts

Parts Required:

- (2) U-Clip Fasteners
- (8) 1/4-20 x 1-1/2" Bolts

A. Place the two (2) U-Clips onto the back of the grill body as shown in Fig. 6. Be sure the flat side faces out.

B. Partially insert one (1) 1/4-20 x 1-1/2" Bolt into each of the four threaded inserts on the side of the Grill Body as shown in Fig. 6. The bolts should only be threaded about half-way in.

Repeat steps 6A and 6B for the opposite side of the grill.

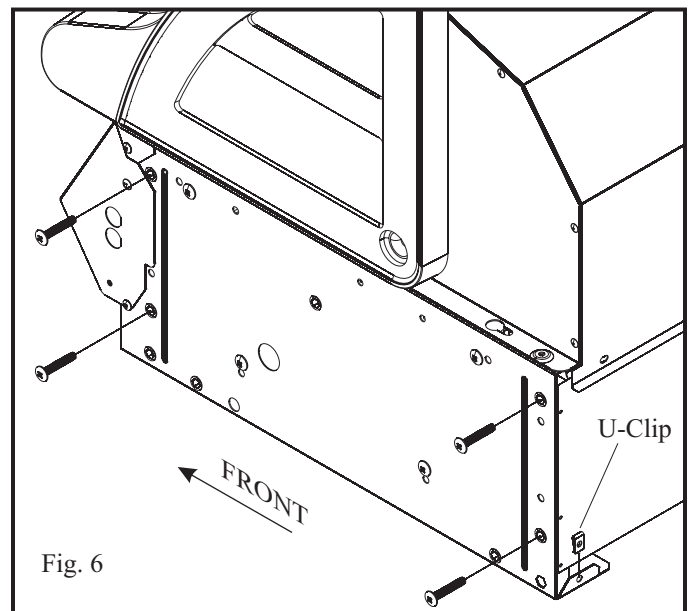

Step 7: Attach the Grill Head to the Cabinet

Parts Required:

- (6) 1/4-20 x 1/2" Bolts
- (2) #10-24 Bolts

Note: Two people are recommended to complete this step.

A. Place the Main Unit on top of the cabinet making sure the lid is held shut before lifting.

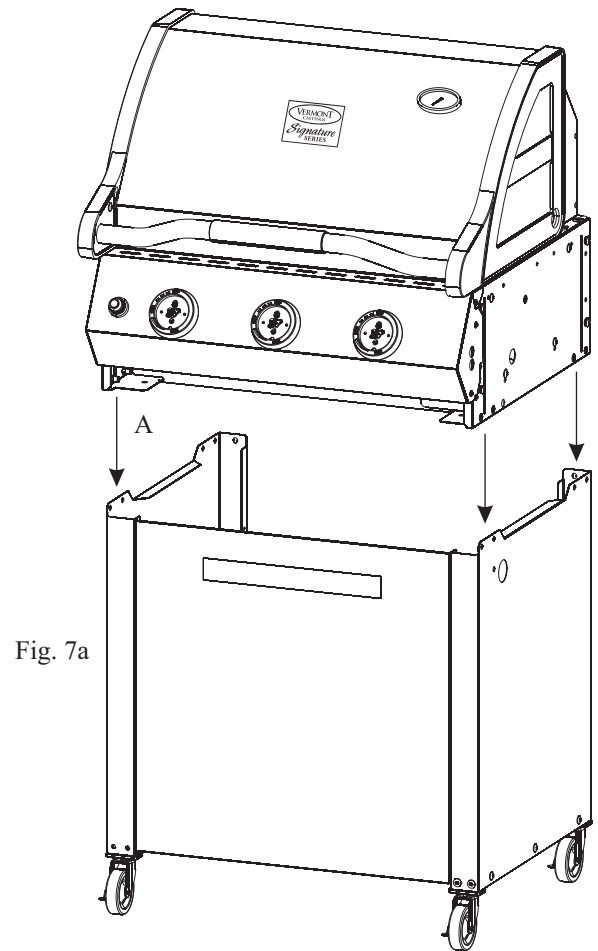

B. Once the Main Unit is fitted on top of the cabinet, insert two (2) #10-24 Bolts through the U-clips installed at the back of the grill head. Securely tighten the bolts.

C. Insert one (1) 1/4-20 x 1/2" Bolt into each of the three holes at the top of the Cabinet Sides (3 bolts per side) as shown in Fig. 7b. Do not tighten these bolts yet; leave them about 1/2 threaded into the holes.

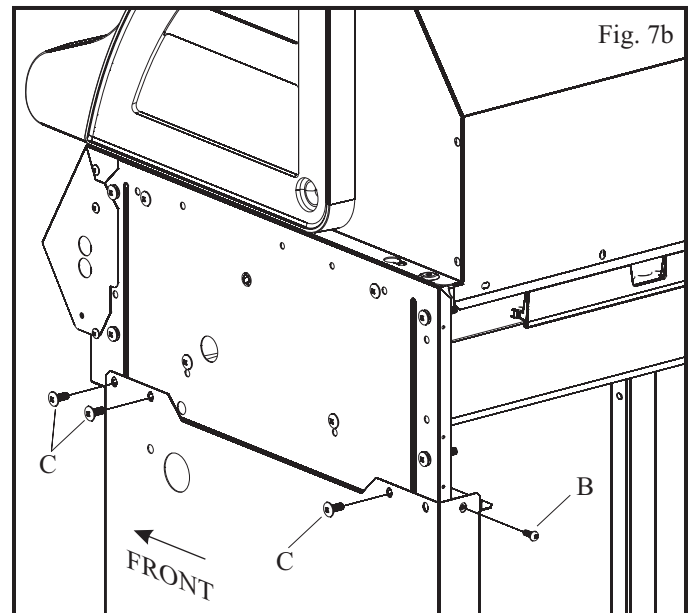

Step 8: Install the Front Fascia

Parts Required:

- (1) Front Fascia

A. Slide the Front Fascia onto the two (2) front bolts from Step 7C as shown in Fig. 8. Next, securely tighten the six (6) bolts to fasten the grill head and fascia in place.

B. Remove the screw shown in Fig. 8 from the unit. This screw must be removed from both sides. A new set of screws has been provided in the hardware bag for when the screws are re-installed in Step 12B.

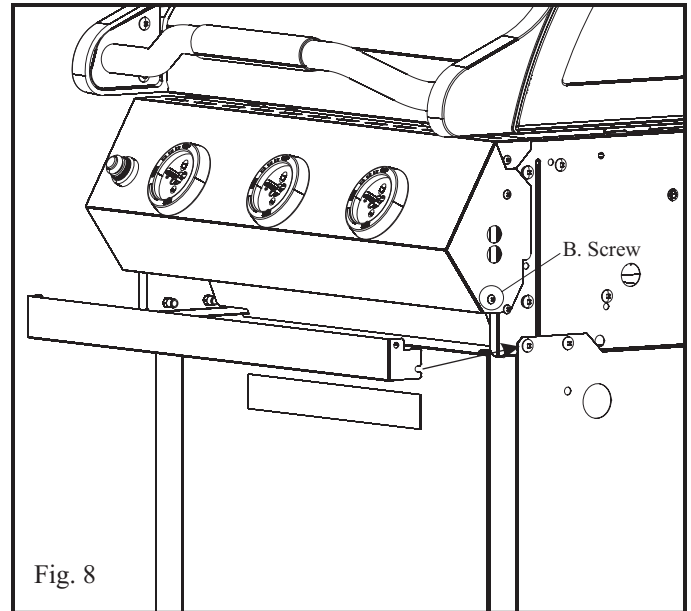

Step 9: Install U-Clip Fasteners to Shelf Supports

Parts Required:

- (2) #10-20 U-Clip Fasteners
- (1) Shelf Support (Left Side)
- (1) Shelf Support (Right Side)

Install the two (2) U-Clip fasteners on the Side Shelf Supports as shown in Fig. 9. One (1) U-Clip should be placed on each bracket, with the flat side down.

Note: The remaining Right Side Shelf Support and Left Side Shelf Support do not require U-Clip fasteners.

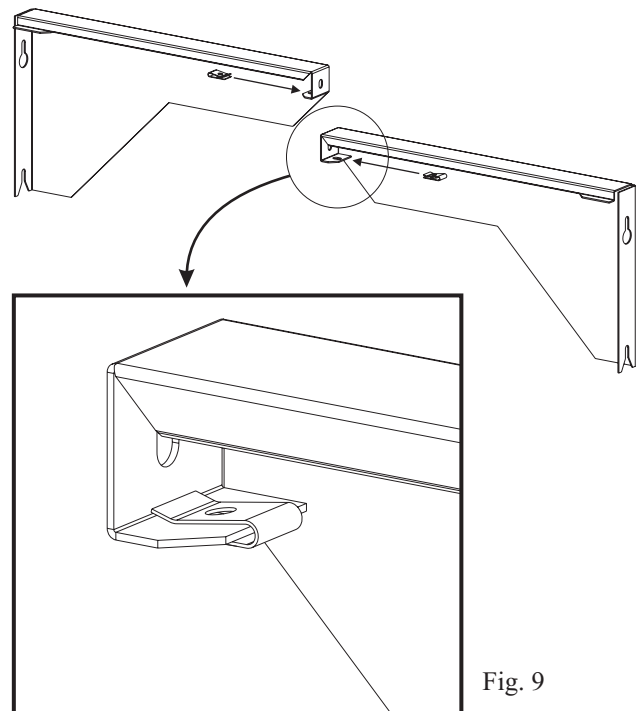

Step 10: Pre-Assemble Side Shelves

Parts Required:

- (2) Shelf Supports (Right side)
- (2) Shelf Supports (Left Side)
- (1) Shelf Right
- (1) Shelf Left
- (2) #10-24 Bolts (black)
- (2) #10-24 Bolts (Stainless)
- (2) #10-24 Lock Nuts

Note: Be sure to remove all protective plastic coating from stainless steel parts.

Use the two (2) Shelf Supports from step 9 (with U-Clip fasteners) in addition to the two (2) remaining Shelf Supports. Each U-Clip support is mounted to the rear of the side shelf.

Secure each Shelf Support to the Shelf by inserting one (1) #10-24 Bolt (black) through the U-Clip at the back corner as shown in Fig. 10 and one (1) #10-24 Bolt (stainless) through the hole at the opposite end and tighten using one (1) Lock Nut. Then repeat the step to secure the other Side Shelf.

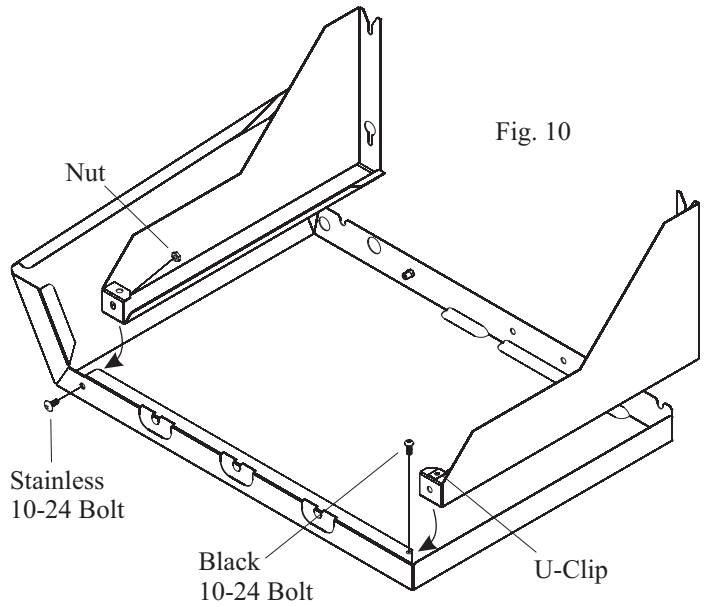

Step 11: Attach the Side Shelves

Align the holes of the Side Shelf Supports over the partially inserted bolts (from step 6) and gently push down until the bolts settle into the slots at the top of the holes. Tighten the bolts fully.

Next: Repeat Step 11 for the other side shelf.

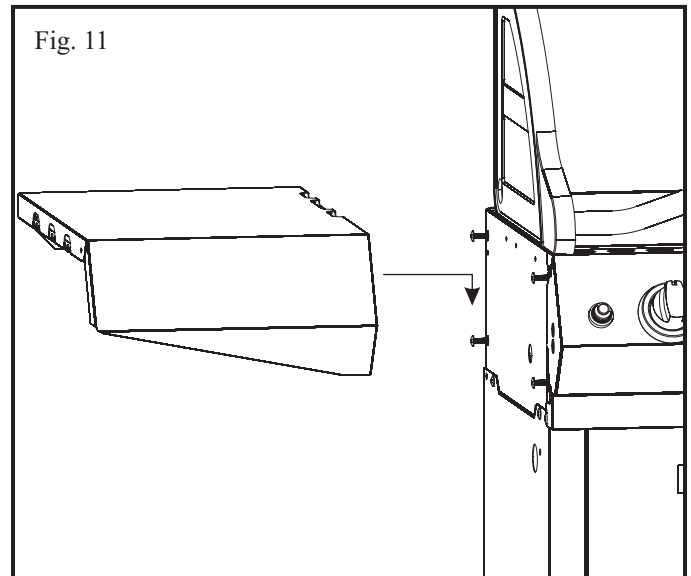

Step 12: Secure the Side Shelves to the Grill Body**Parts Required:**

- (2) #8-18 x 1/2" Screws
- (2) #10-24 x 1/2" Bolts

A. Lift the grill lid and insert one (1) #10-24 x 1/2" bolt, shown as "A" in Fig. 12a, to further secure the right shelf to the grill body.

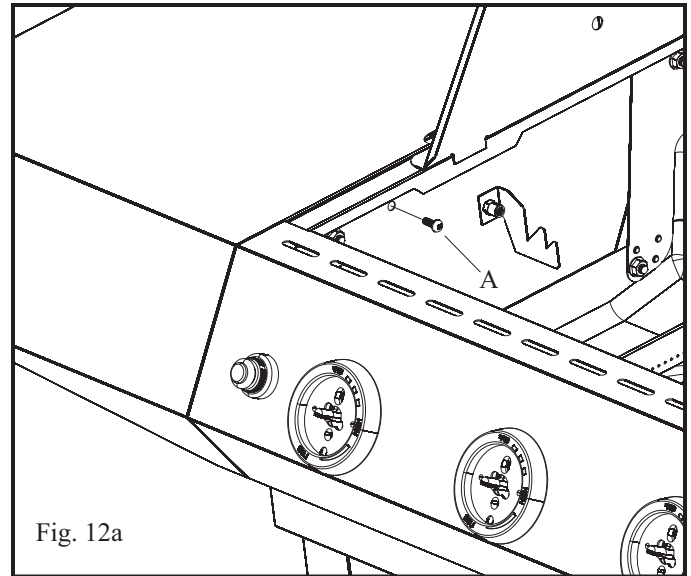

B. Attach the left shelf to the Console by inserting one (1) #8-18 x 1/2" Screw as shown in Fig. 12b.

Next: Repeat Steps 12A and 12B to secure the right shelf to the grill body.

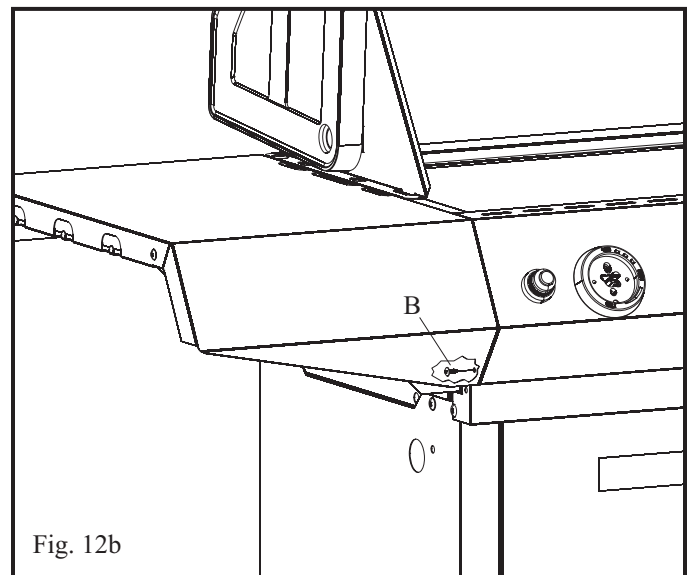

Step 13: Attach Shelf Insert

Note: If you have purchased the optional side burner, skip this step and refer to the instruction sheet included with the side burner for installation instructions.

Parts Required:

- (1) Lid (S/B-Single)
- (4) #10-24 x 1/2" Bolts
- (4) #10-24 Lock Nuts

Note: Be sure to remove all protective plastic coating from stainless steel parts.

Place the Lid (S/B-Single) in the opening on the right shelf so it sits flush with the top of the shelf.

Next, attach the Insert to the right shelf using four (4) #10-24 x 1/2" Bolts and four (4) #10-24 Lock Nuts.

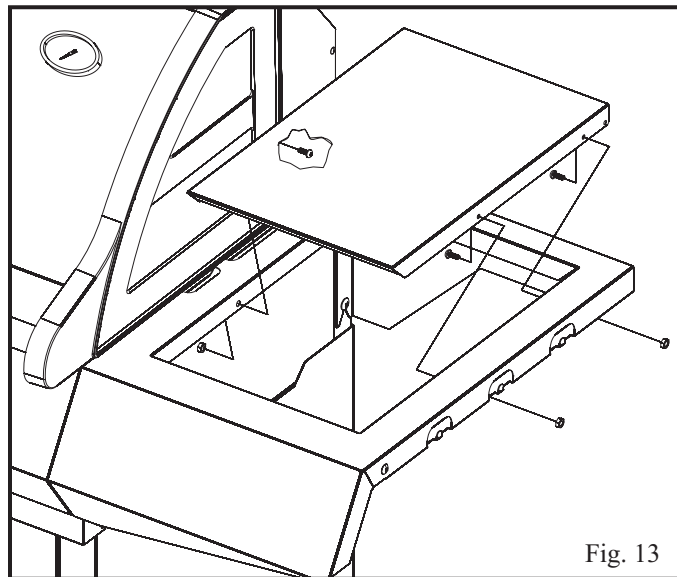

Step 14: Attach Knobs

Parts Required: (3) Knobs

Align the knobs on the valve stems and push inward until the knob sits snugly on the stem.

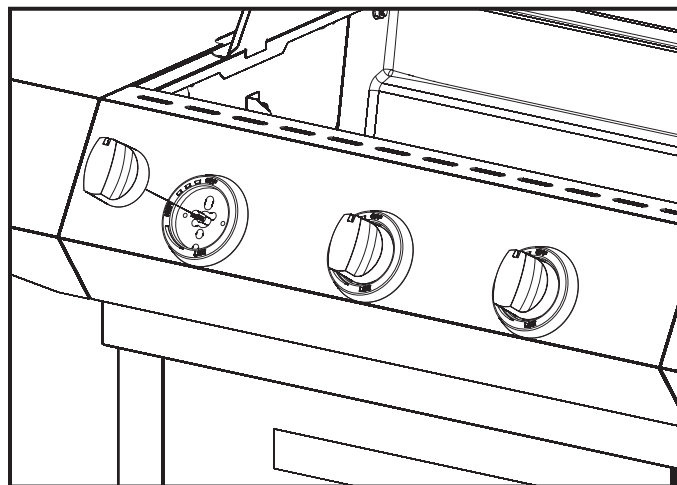

Step 15: Install Grease Cup, Cup Holder and Pan

Parts Required:

- (1) Pan
- (1) Grease Cup
- (1) Grease Cup Holder

Attach the Grease cup Holder to the Grease Cup by inserting the vertical prongs through two of the holes in the lip of the Grease Cup on the narrow side.

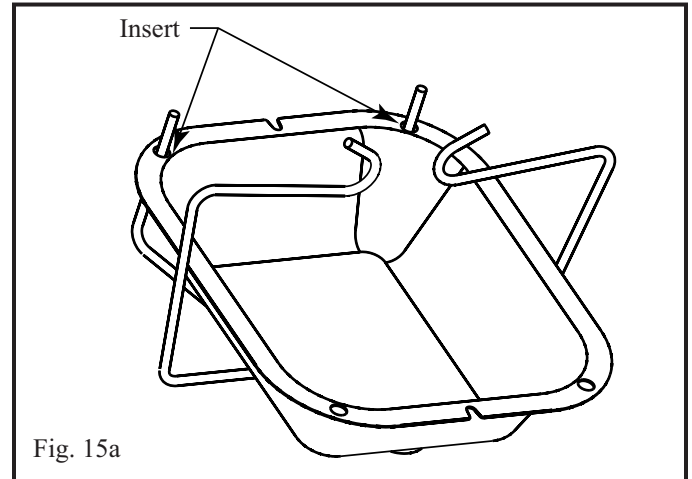

Next: Attach the Grease Cup Holder to the bottom of the grease pan by squeezing the two hook ends of the holder together until they can fit into the opening of the grease pan.

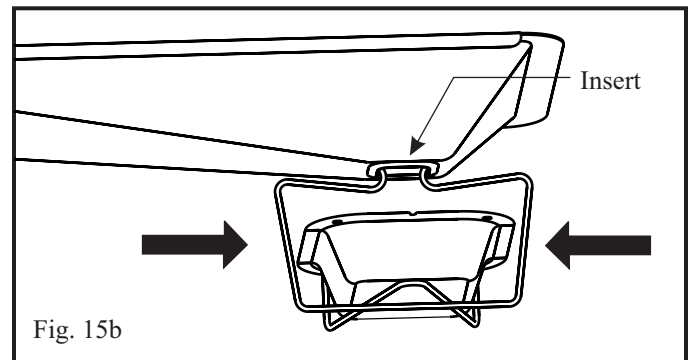

Then slide the grease pan into the two support rails under the back of the grill with the cup and pan opening on the right side. Be sure the pan settles into place on the support rails to ensure there will be no leakage.

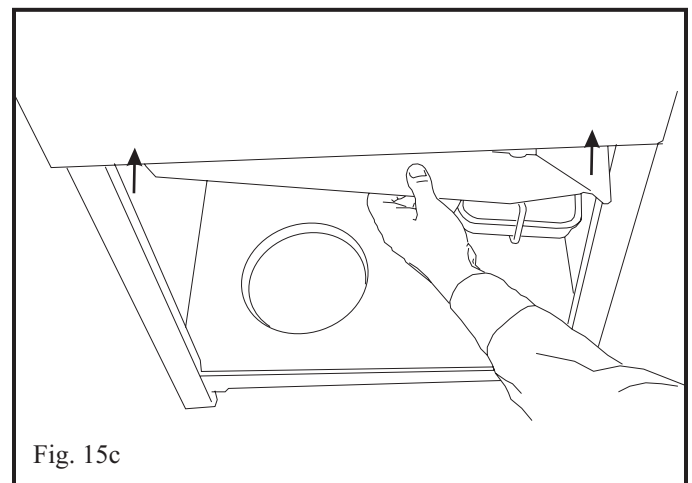

Step 16: Install the Internal Components

Parts Required:

- (3) Sear Plates
- (2) Cooking Grates
- (1) Warming Rack

Carefully place each of the three (3) Sear plates side by side inside the barbecue, making sure the semicircular finger groove is facing toward the front of the grill. Each sear plate rests just above each burner tube.

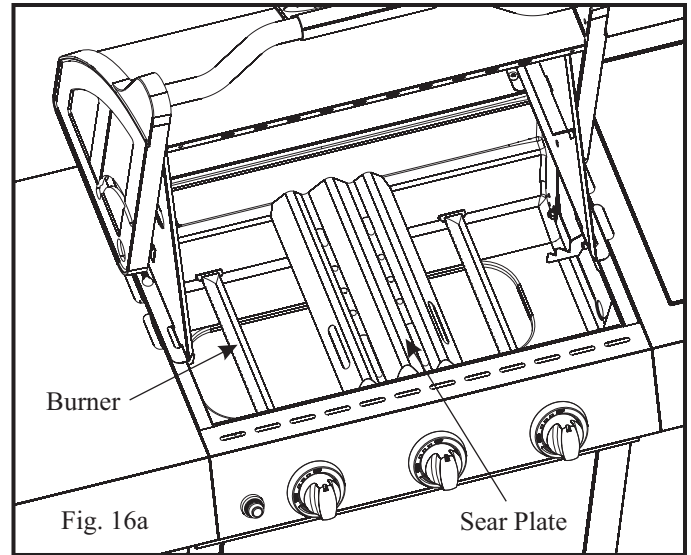

Next, set the two (2) cooking grates, side by side, on the upper ledge of the grill tub. Make sure the finger groove is facing toward the front of the grill.

Set the warming rack into the supports located on either side of the rear lid.

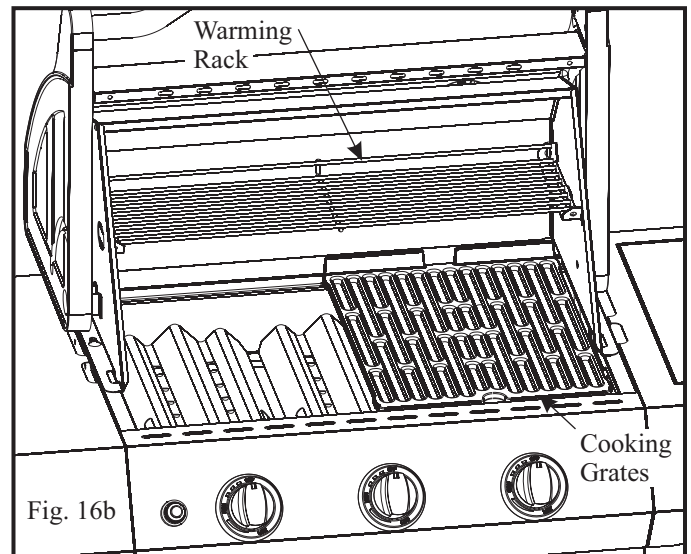

Step 17: Install the Battery

Parts Required: (1) “AAA” Battery

Unscrew the Ignition Button from the console and insert a “AAA” battery into the housing by placing the positive side of the battery in first. Then screw the Ignition button back into the console.

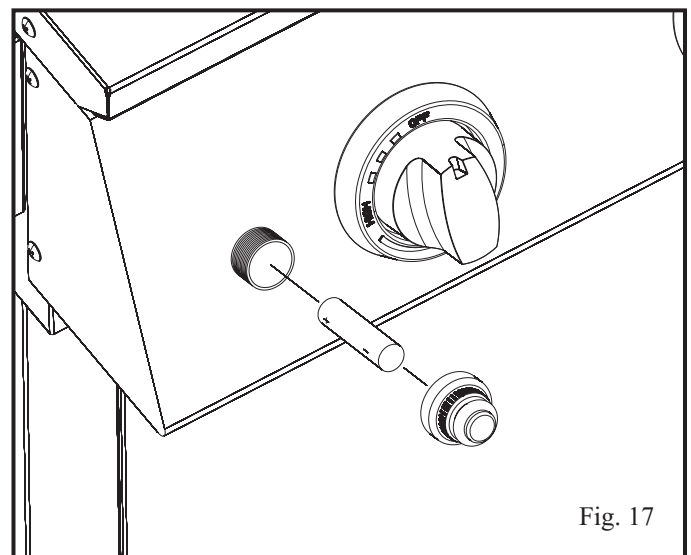

Step 18A: Install the LP Cylinder (LP Models Only)**Parts Required:**

- (1) LP Gas Cylinder (not included)
- (1) 1/4-20 x 2-1/2" Thumbscrew

Note: Check your user's manual for the cylinder filling requirements, how to attach the regulator and how to test for leaks before you try lighting the grill.

Caution: Make sure the hose is not touching any hot surfaces.

Place the LP Cylinder into the hole in the bottom panel.

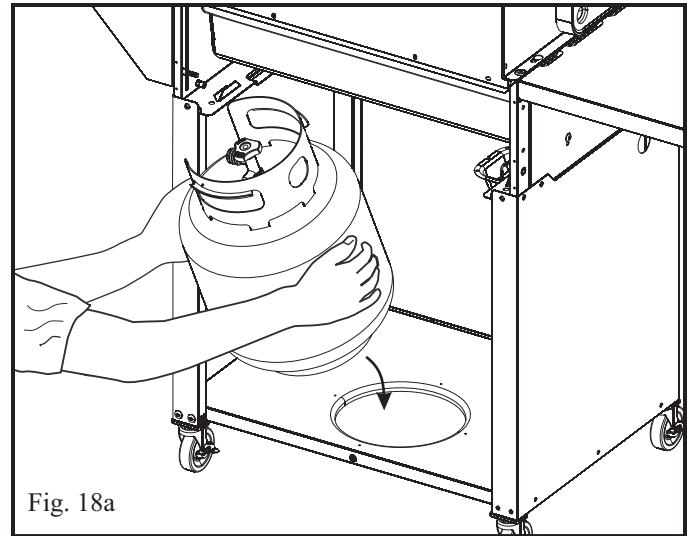

Fig. 18a

Next, to secure the LP Cylinder, insert the thumbscrew into the threaded hole next to the cylinder holder as shown. Securely tighten the thumbscrew.

Note: Ensure all plastic coatings have been removed from all stainless steel parts before using the grill.

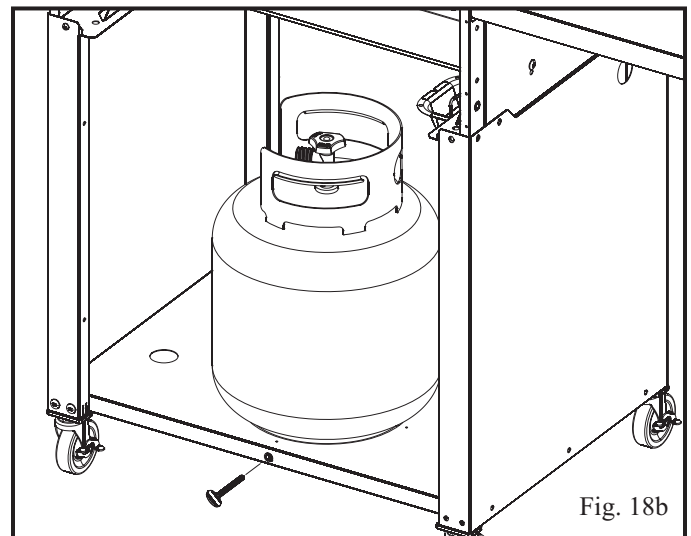

Fig. 18b

Step 18B: Install the NG Hose Bushing (Natural Gas Models Only)

Parts Required: (1) Plastic bushing

Tools Required: Hammer, Flat Head Screwdriver

Remove the Knock Out Hole from the bottom panel using a hammer and flat screwdriver by placing the screwdriver on the slug and delivering a sharp blow with the hammer.

Next: Snap the bushing into place to line the hole and feed the Natural Gas hose through the opening before connecting it to the gas supply.

Caution: Consult with you local fuel supplier before connecting to the fuel supply.

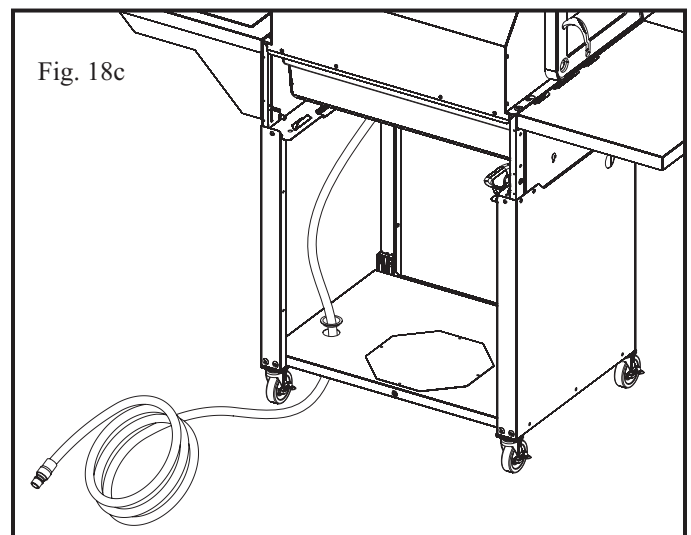

Fig. 18c



www.cfmcorp.com

Service Note: If you are experiencing difficulties or are dissatisfied with your purchase, please contact CFM at the telephone number listed above prior to returning your grill to the store.