

HEPA Air Purifier

MODEL PJ152NP

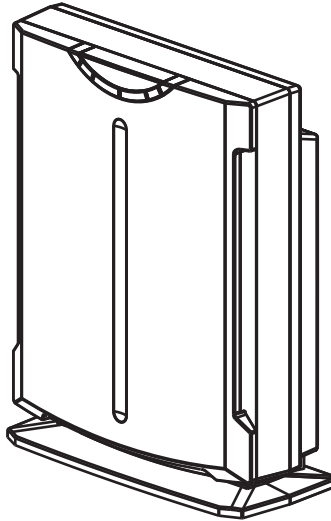

USER MANUAL

- Position the air purifier on a stable horizontal surface. Do not obstruct the air inlet and air outlet.
- This machine is for indoor use only.
- Do not run the air purifier without using a filter.

**Please read this instruction manual
before operating and keep safe for future reference**

IMPORTANT SAFETY INSTRUCTIONS

When using any electrically powered product, basic safety precautions should always be followed.

PLEASE READ ALL INSTRUCTIONS CAREFULLY BEFORE USING THE PRODUCT.

1. Check the household voltage to ensure it matches the units rated specification before operating.
2. Close supervision is necessary when the unit is used by or near children or pets, or left unattended.
3. Do not allow children to play with any product packaging, such as plastic bags.
4. Do not operate the unit with a damaged cord or plug, after the product malfunctions, or has been dropped or damaged in any way. Return the complete product to an authorised service facility for examination and repair.
5. This product is intended for domestic use only and not for commercial, industrial or outside use.
6. Always turn the unit off and unplug before moving location.
7. To disconnect from the power supply, grip the plug and pull from the power socket. Never pull by the cord.
8. Do not operate the unit in areas where petrol, paint, or other flammable liquids are used or stored.
9. Do not use the unit in artificially hot or humid conditions or allow it to be used in any hazardous environment.
10. Do not place the unit near an open flame, cooking or heating appliance, or hot surface.
11. This unit is not intended for use in wet or damp locations. Never locate the unit in an area where it may fall into a bath or other water container. Always use on a dry level surface.
12. Do not let the power cord hang over the edge of a table or counter. Arrange the power cord away from an area where it may be tripped over.
13. Never place the power cord under a carpet or rug.
14. Do not place objects on the product or allow objects to obstruct the inlet or outlet openings. Do not operate in close proximity to walls or curtains, etc.
15. The use of attachments or accessories not recommended or sold by the product distributor is not recommended as they may cause injury to persons or property and void the warranty.
16. Do not attempt to repair the unit other than to replace or clean the filters. To repair the unit take it to a qualified service engineer.
17. Set on "high speed" to clean room air rapidly and then turn to lower speed half an hour later. When used at night, set the speed at lower grade to keep the air fresh and clean.
18. Do not wash the filter cartridge (HEPA). The cartridge is not washable and doing so will cause damage.
19. Place the unit 90cm above floor level for best performance. The unit should never be used at floor level if the room is carpeted.
20. If the supply cord is damaged it must be replaced by the Manufacturer or an authorised service centre in order to avoid a hazard.

SAVE AND READ THESE IMPORTANT SAFETY INSTRUCTIONS

BS PLUG WIRING

Wiring Instructions: Should it be necessary to change the plug please note the wires in the mains lead are coloured in accordance with the following code :

BLUE - NEUTRAL

BROWN - LIVE

GREEN AND YELLOW - EARTH

As the colours of the wires in the mains lead of this appliance may not correspond with the coloured markings identifying the terminals in your plug, proceed as follows:

1. The **BLUE** wire is the **NEUTRAL** and must be connected to the terminal which is marked with the letter **N** or coloured **BLACK**.
2. The **BROWN** wire is the **LIVE** and must be connected to the terminal which is marked with the letter **L** or coloured **RED**.
3. The **GREEN/YELLOW** is the **EARTH** and must be connected to the terminal which is marked with the letter **E** or \oplus or coloured **GREEN OR GREEN/YELLOW**.
4. Always ensure that the cord grip is positioned and fastened correctly.

If a **13A (BS 1363)** fused plug is used it must be fitted with a **13A** fuse. If in doubt consult a qualified electrician.

Wiring for a 13 Amp Plug (BS1363)

Please note. The Earth Terminal is marked with the letter **E** or \oplus Earth Symbol.

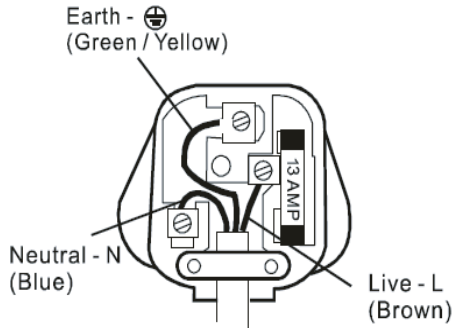

1. Purification function:

This purifier is equipped with a filter system, which consists of a HEPA filter, activated carbon.

HEPA filter captures 99.97% of airborne particles as small as 0.3 microns.

The filter system can eliminate smoke, harmful gases (formaldehyde, carbon, monoxide, etc) and odours, absorb and decompose harmful bacteria in the air, thus reducing air pollution and improving air quality in the home.

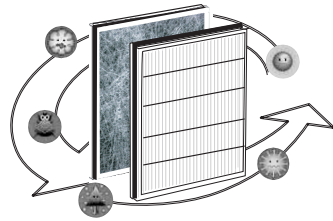

2. Negative ion function:

Negative ions are discharged to combine with dust, bacteria, mildew in the air, and remove them.

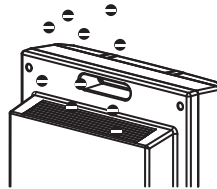

3. Photocatalyst function:

A special filter combined with light performs a deodorisation of the air (removing smells not merely disguising them) and a sterilisation effect reducing the impact of germs and viruses.

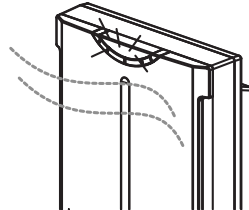

PARTS DESCRIPTION

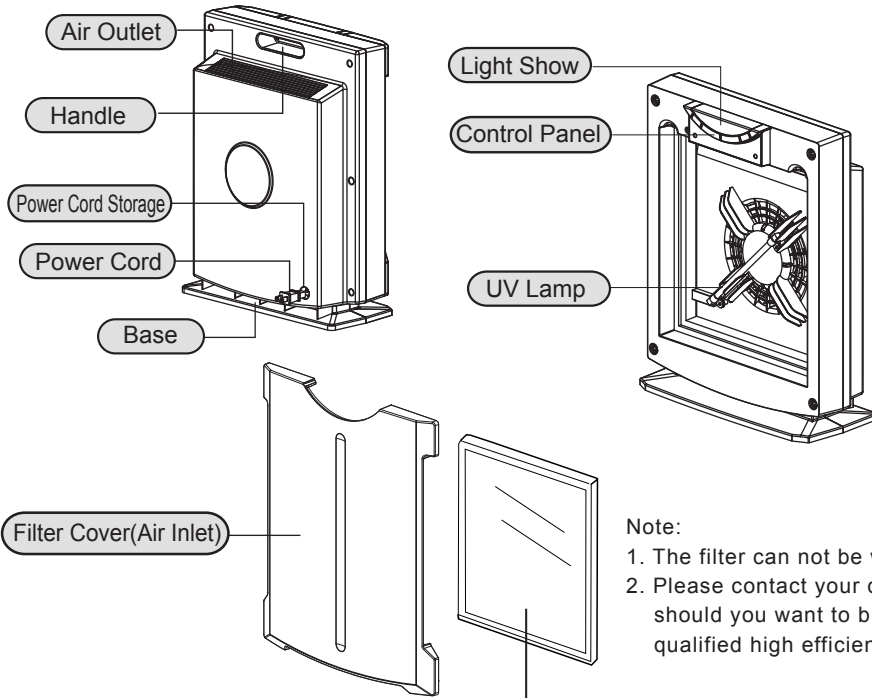

Four Layers High Efficiency Filters

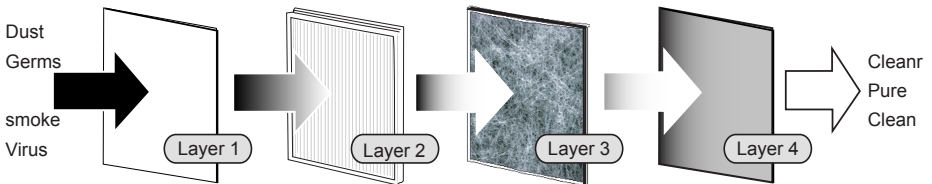

Layer 1- Nano Sliver Pre Filter

Electrostatic Filter can catch duty and powder into filter.
Nano Sliver can restrain germs.

Layer 2-Medical Class HEPA (Inside)

Removes 99.97% Airborne Particles(@0.3 Micron)

Layer 3- Activate Carbone Filter (Inside)

Get rid of others chemical pollutions, including powder, stinking smell, harmful air.

Layer 4-Photo Catalyst Filter-Tio₂ (Back Light Blue)

Photo Catalyst Filter (Tio₂) can restrain germs, microbe, bacillus and virus action.
Provide you a healthy life.

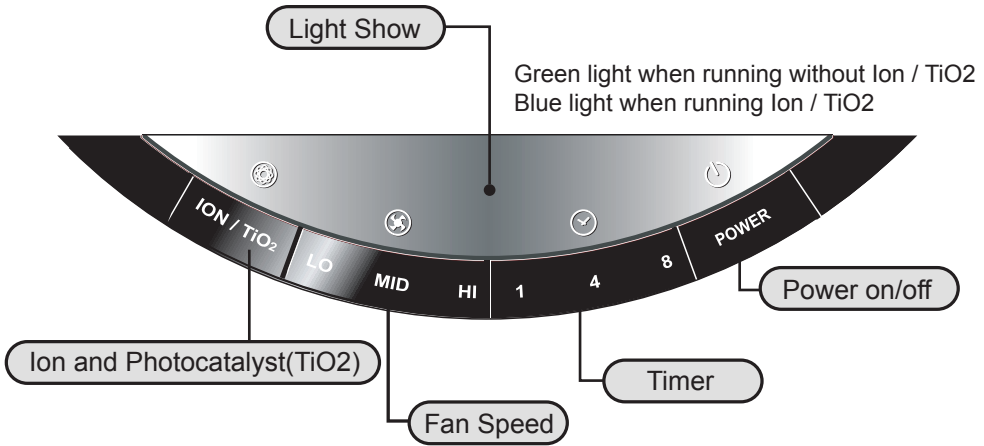

1. Ensure filter is unpacked and installed before operation.
(Refer to Installation Instructions Section).

Best performance:

We recommend that you operate your air cleaner 24 hours a day because indoor air can be quickly contaminated by activity in a room, for example outside air, smoking, and other air pollutants. While the air cleaner will not process all the air in a room, the more air circulated through the filter, the more filtered air is returned to the room. Portable air cleaners will be much more effective in rooms where all doors and windows are closed. However, for best performance the air outlet slot should be kept clear, at least 1 meter (three feet) in all directions.

2. Insert the main's plug into a suitable power socket.
3. Press the POWER button to turn your air cleaner ON, the fan will start at LOW speed. To turn the air purifier OFF, press the POWER button again. When you turn your Air Purifier on again the fan will operate at the last speed selected, unless the power was disconnected.
4. Press the FAN SPEED button to select LOW, MEDIUM or HIGH speed.
5. Your Air Purifier can be turned off by the TIMER after 1, 4 or 8 hours by depressing the TIMER button. There is an LED to show when the TIMER mode has been selected.
6. The ION and PHOTOCATALYST mode is selected by pressing the ION/TiO2 button. In this mode your Air Purifier emits negative ions that enhance the air purification efficiency and provide a fresh air feel to the air. In addition the PHOTOCATALYST mode helps to prevent viruses, germs and microbes from circulating around the room. The Control Panel glows BLUE when the ION and PHOTOCATALYST mode is turned on. When these functions are turned off the control panel glows GREEN.

CAUTION: SWITCH OFF AND DISCONNECT FROM POWER SUPPLY BEFORE SERVICING.

1. To clean the unit use a soft cloth to wipe off any dust. If the unit is very dirty use a damp cloth. Do not use any cleaning detergents, sprays or any other chemicals as these will damage the unit. Ensure no water enters into the machine.
2. Replace the HEPA filter when the white surface of HEPA filter turns black, when you notice that the Carbon Filter is no longer removing the smells or after 6 months.
3. Do not use your unit in areas where there is thick dust or smoke, as this will damage the filter.

TROUBLESHOOTING

If your air purifier stops working please check the following items first

When unit fails to run:

- ➡ Is power cord unplugged or the power off?
- ➡ Is the filter cover not in place?

When the performance seems poor:

- ➡ Does use for a large space?
- ➡ Is the filter dirty? Clean it.
- ➡ Is the inlet or the outlet covered?
- ➡ Is the machine unsuitable allocation?

When noise occurs:

- ➡ Is the unit on a flat level surface. Move the machine.
- ➡ Is the air filter dirty? Clean the filter.

Should there still be a problem, please unplug the unit and contact us.

SPECIFICATIONS

Model: PJ152NP

Power: 51W(High) / 38W(Mid) / 29W(Low)

Ventilation(Cfm): 65(High) / 50(Mid) / 35(Low)

Voltage: 220-240V ~ 50Hz

N.W: 4 Kg(including filter)

G.W: 5 Kg

SERVICE AND WARRANTY

If the supply cord is damaged it must be replaced by the Manufacturer or an authorised service centre in order to avoid a hazard.

For your convenience, record the complete model number and product name (located on the Product Identification Plate), the date you purchased the product, and attach your purchase receipt docket as proof of purchase. To ensure your product is covered by warranty, the complete faulty product together with your purchase receipt should be returned to your retailer.

ONE (1) YEAR LIMITED WARRANTY **Save This Warranty Information**

EHS (International) Ltd. guarantees this product free from defects in materials and workmanship for a period of one (1) year.

Should this unit be operated under conditions other than those recommended or at voltages other than the voltage indicated on the unit, or any attempts made to service or modify the unit, will render this **WARRANTY VOID**. The product you buy may sometimes differ slightly from illustration. This warranty is in addition to, and does not affect, your statutory rights.

Should you have a problem with this product, please call our Help Desk on: (0870) 742 5021.

This product has been manufactured to comply with EEC Directives 73/23/EEC and 89/336/EEC

EHS, Manchester, M17 1RN

EHS 10/09



EHS, Manchester, UK
Printed in P.R.C.