

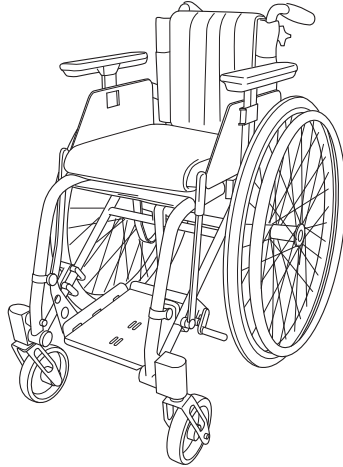

# User manual

## Rigid frame wheelchairs, English

74591C 13-08-15

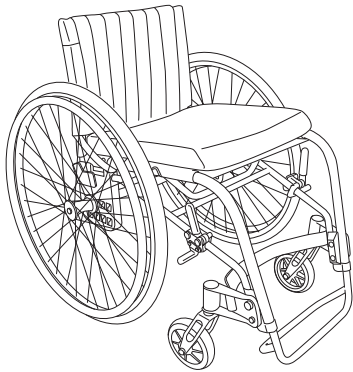

Contents	Page	Explanation of symbols
Car transport .....	2	
Handling .....	3	
Sitting comfort .....	4-5	
Transfer .....	6	
Handling technique .....	7	
Troubleshooting table .....	8	

Do not lift the chair using the armrests.

Risk of tipping:  
Always have the anti-tip stabilisers down when moving.



When adjusting seat height, balance-position or backrest angle, operation of the anti-tip stabilisers must be checked.

## Vehicle transport Mobility service bus

Etac's wheelchairs are crash-tested and approved in accordance with ISO-7176-19 and ISO 10542, with attachment features and three-point belts from Unwin. Etac recommends in the following order:

1) The user transfers to a seat in the vehicle and uses the vehicle's 3-point belt while travelling. The wheelchair is then placed in the boot or safely in the back seat so that it cannot overturn or roll.

2) The wheelchair is secured facing forwards in the vehicle as per this manual, the user uses a separate 3-point belt that is secured in the vehicle. This is the way in which the wheelchair is tested and approved according to the ISO-standard for crash testing of wheelchairs in vehicles.

3) According to directive 2001/85/EC, appendix VII, point 3.8.3. there are specially marked wheelchair locations in vehicles that permit transport with a wheelchair facing in the direction of travel. If this means of travel is used, the user/carer must be aware while travelling, prepared for sudden movements and have the capacity to maintain a safe sitting position throughout the entire journey. The user's disabilities must not be of such an extent that he/she is not able to hold onto the handles fitted in the vehicle when there are changes of speed or direction.

In conjunction with points 2 and 3:

- a 25668 positioning belt should be used
- a correctly adjusted headrest should be used
- the backrest should be level with or above the user's shoulders
- the parking brake should be used
- the anti-tips should be lowered

### Tie-down

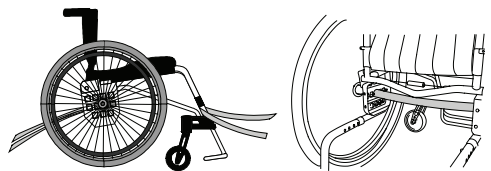

### Car/taxi

- Ideally, the wheelchair should be placed in the boot.
- If the chair is placed in the back seat, ensure that it cannot tip over or move.  
Secure it, if possible using the vehicle's seat belts.

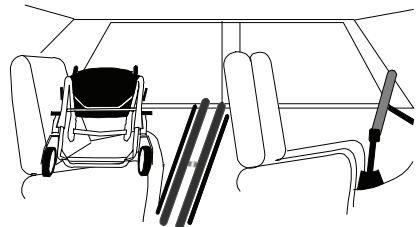

## Unfolding

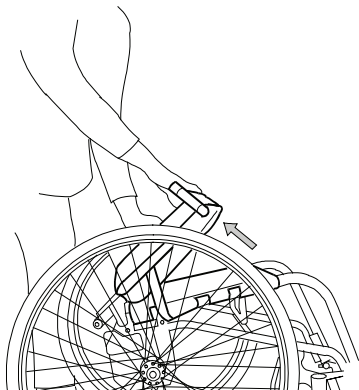

- Lift up the backrest. This locks in the raised position.
- Fit the rear wheels, see below.

## Folding

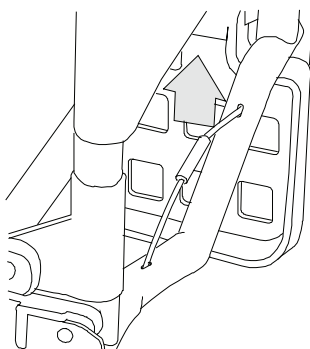

- Fold the backrest by pulling the wire upwards. The elastic strap keeps the backrest in the folded position.
- Remove the rear wheels, see below.

## Rear wheel with quick release

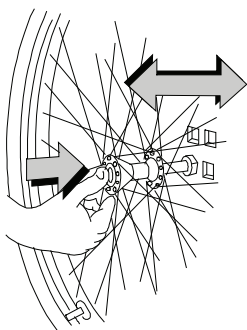

- Fitting/removal: Depress the button in the hub while fitting/removing the wheel.



When assembling, always check that the rear wheel is correctly positioned.

The button in the hub must spring out properly.

## Anti-tip feature

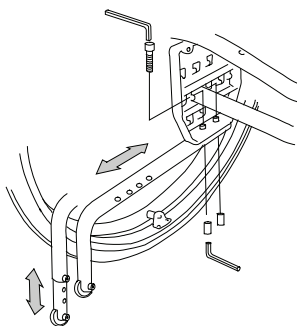

- It is possible to adjust both the height and length.
- Test how far back you would like the wheelchair to be able to tip.
- You must be able to move easily, yet still feel secure.

## Back cover



- Place the back cover far enough back on the seat for a fold to be formed between the backrest and seat.
- It is important to always place the back cover on the seat in this way, as it affects user comfort when seated.

## Seat cushion

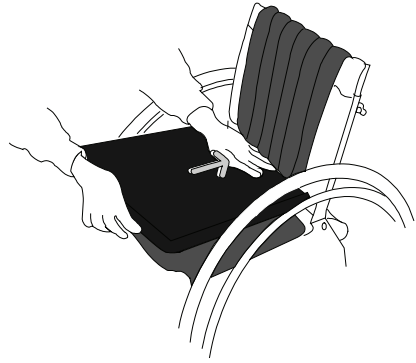

- Place the cushion far enough back on the seat that the rounded corners are between the back tubes.
- Trim the cushion to suit seat depth.
- If using comfort wedge, place this in the pocket of the cover under the cushion.

## Footrests

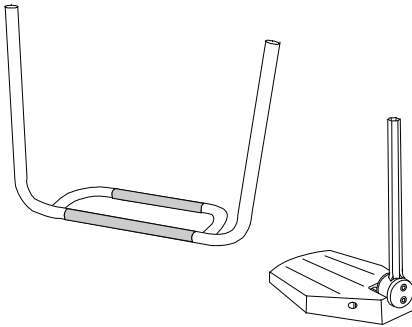

- Adjust the height until you are sure that your feet are supported and your thighs are resting on the cushion.
- Split footrests: Adjust the angle, so the ankles are at 90°.

## Calf strap

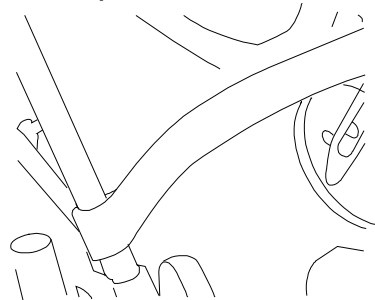

- Adjust the length so that your insteps rest on the footrests.

## Back upholstery

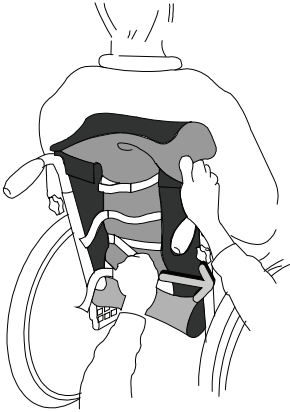

- Loosen all back straps.
- Tighten the strap just below the curve of the back.
- Adjust the other straps to allow space for the bottom and follow the natural curve of the back.

## Backrest angle

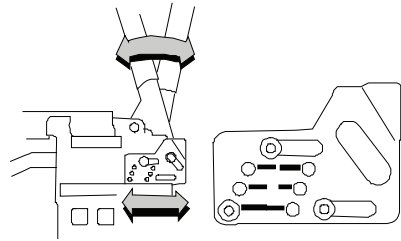

- Check the backrest angle when adjusting the shape of the back upholstery.

## Comfort

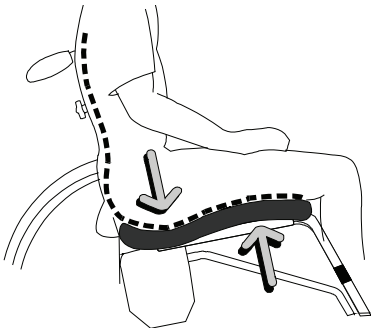

Good comfort when seated requires a well-shaped seat that provides:

- Pressure distribution.
- Stability.
- Freedom of movement.

# Transfer to/from a wheelchair

## Sideways

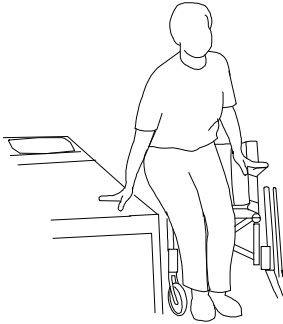

- Back the wheelchair up 5-10 cm before stopping so that the castors are facing forwards.
- The wheelchair should be close to the transfer point.
- Lock the brakes.
- Remove the armrest/siderest on the transfer side.

## From the front



- Back the wheelchair up 5-10 cm so that the castors are facing forwards.
- The wheelchair should be close to the transfer point.
- Lock the brakes and flip up the footrests.

 Do not stand on the footrests, risk of tipping!

## Parking

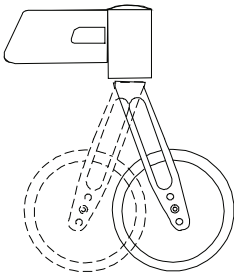

- Increase the support area of the wheelchair by backing up 10 cm so that the castors are facing forwards.
- Helper: Lock the brakes and ensure that the anti-tip stabilisers are lowered.

## Lifting the wheelchair

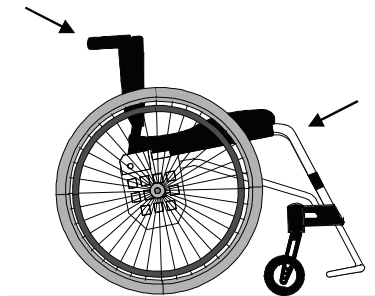

 Check that the height-adjustable push handles are properly tightened.

## Travelling uphill

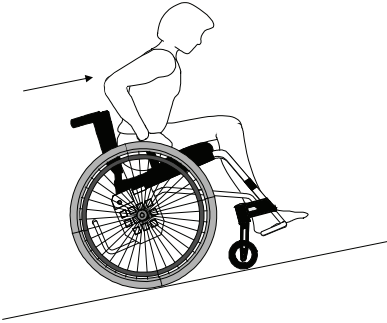

- Lean your body forwards to correct the centre of gravity.
  - Control your speed using the handrims, not the brakes!
  - Always travel up/down as directly as possible.
  - If you are unsure, ask for help.

## Travelling downhill

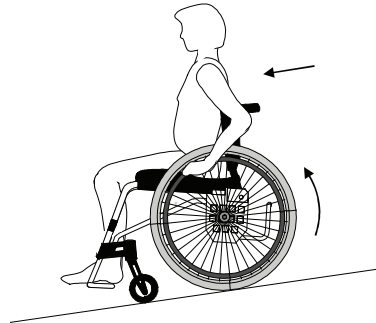

- Lean your body back to correct the centre of gravity.

## Stairs

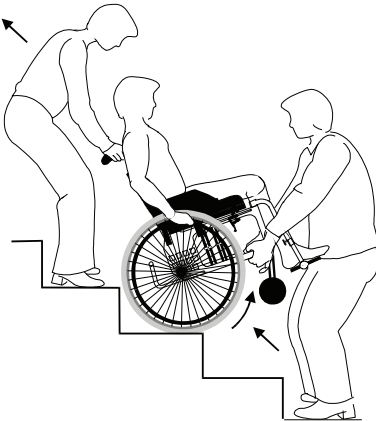

- Always ask for help. We always recommend using two carers for this transfer.
- Flip up the anti-tip stabilisers.
- Ascending: With the wheelchair facing backwards.
- Descending: With the wheelchair facing forwards.
- Never use an escalator, even with a helper present.

## Kerbs

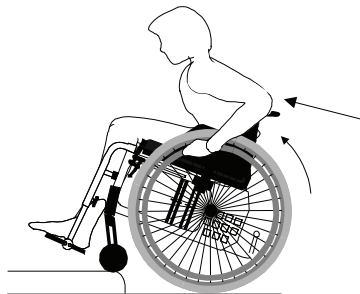

- Flip up the anti-tip stabilisers.
- If you are unsure, ask for help.
- Up: Balance the chair so that the castors leave the ground. Lean your body forwards and take a strong grip on the handrims.
- Down: Move forwards slowly so that all four wheels touch the ground at the same time.

## Maintenance

- Rear wheels: Clean quick release axles as required.
- Tyre pressure: Check the tyre pressure, see tyre section (once/month).
- Castors: Clean castor wheel axles as required.
- Chassis: Clean the chassis with non-abrasive detergent, pH value 5-9 or with 70 % disinfectant solution. Rinse and dry.
- Upholstery: Wash, see labels on each item.
- In the event of problems, contact your dealer or Technical Aids Centre.  
(!) If necessary, lubricate moving parts/joints with cycle oil or similar.

## Troubleshooting table

The wheelchair is pulling diagonally	<ul style="list-style-type: none"> <li>• Pump up the tyres</li> <li>• Adjust the angle of the front fork attachments</li> <li>• Check that the front fork attachments are fitted at the same height</li> <li>• The rear wheel mountings are incorrectly fitted</li> <li>• The user's weight is not evenly distributed in the wheelchair</li> <li>• More strength being used on one side than the other when propelling the chair</li> </ul>
The wheelchair is "heavy" to manoeuvre	<ul style="list-style-type: none"> <li>• Pump up the tyres</li> <li>• The rear wheel mountings are incorrectly fitted</li> <li>• Clean any hair and dirt from the castor axles</li> <li>• Check the angle of the front fork attachments</li> <li>• Too much weight over the castors; adjust the chair's balance position</li> </ul>
The wheelchair is awkward to turn	<ul style="list-style-type: none"> <li>• Pump up the tyres</li> <li>• Check that the front forks are not tightened too much</li> <li>• Clean any hair and dirt from the castor axles</li> <li>• Too much weight over the castors; adjust the chair's balance position</li> </ul>
The brakes are poor	<ul style="list-style-type: none"> <li>• Pump up the tyres</li> <li>• Adjust the distance between tyre and brake</li> </ul>
The rear wheels are "loose"	<ul style="list-style-type: none"> <li>• Adjust the hub axle length</li> </ul>
The rear wheels are difficult to get on/off	<ul style="list-style-type: none"> <li>• Lubricate and clean the quick release with cycle oil or similar</li> <li>• Adjust the hub axle length</li> </ul>
The castors "wobble"	<ul style="list-style-type: none"> <li>• The front forks have not been tightened sufficiently</li> <li>• Adjust the angle of the front fork attachments</li> <li>• Too much weight over the castors; adjust the chair's balance position</li> </ul>
The wheelchair feels "unsteady"	<ul style="list-style-type: none"> <li>• Pump up the tyres</li> <li>• Check that screws and controls are properly tightened</li> </ul>

Etac

Box 203, 334 24 Anderstorp

Tel +46 371 58 73 00

Fax +46 371 58 73 00

www.etac.com



Etac Supply Center AB

Långgatan 12

SE-334 24 Anderstorp

Sweden

