

Front Change Code digital lock

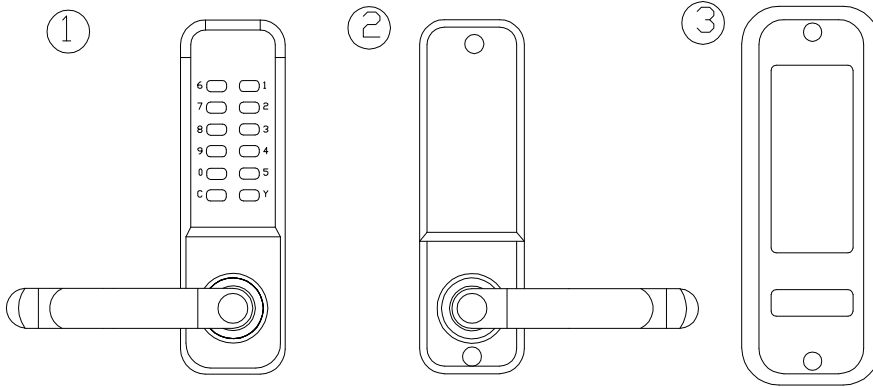

Box Contents:

1. Front plate
2. Back plate
3. Neoprene seals x 2
4. Spindle
5. Latch
6. Strike plate
7. Wood screws x 4
8. Fixing bolts x 2

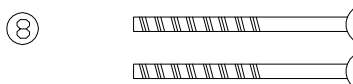
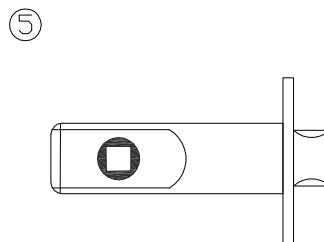
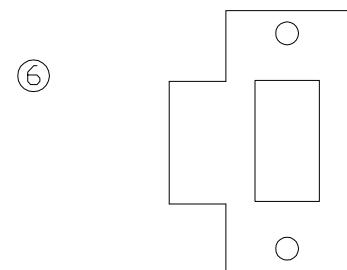
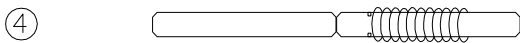

Tools Required

Power Drill
10mm, 12mm, 15mm & 25mm drill bits
Philips screwdriver
Hammer/mallet
Chisel 25mm
Stanley knife
Adhesive tape, pencil, bradawl, tape measure

Installation

Check the hand of your door

Your door is right handed if, viewed from outside, the hinges are on the right.

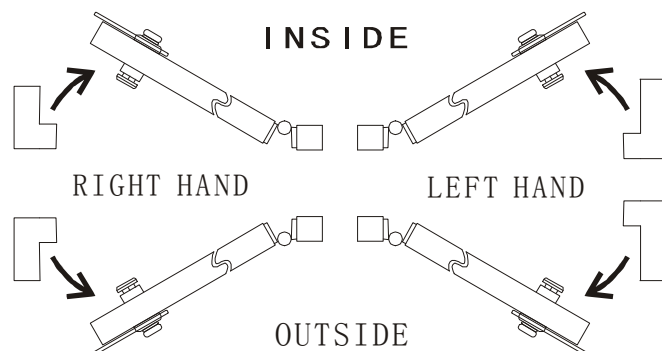

Apply the template

1. Tape the template to the door. Make sure that you fold it along the appropriate line, depending on the backset of the latch (60mm).
2. Mark and drill two 10mm, one 12mm and 14mm holes.
3. Mark a central point on the "centre line of latch" on the door edge.
4. Drill a 25mm hole x 85mm deep.
5. Insert the latch into the hole, and draw around the face plate.
6. Remove the latch and cut a 3mm rebate so that the face plate will fit flush with the door.
7. Secure the latch with the wood screws.

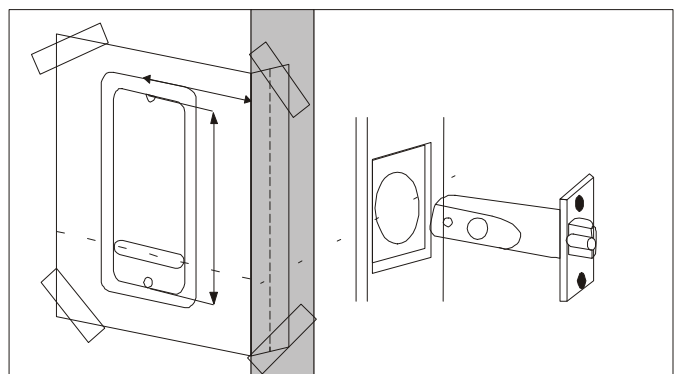

Fitting the strike plate

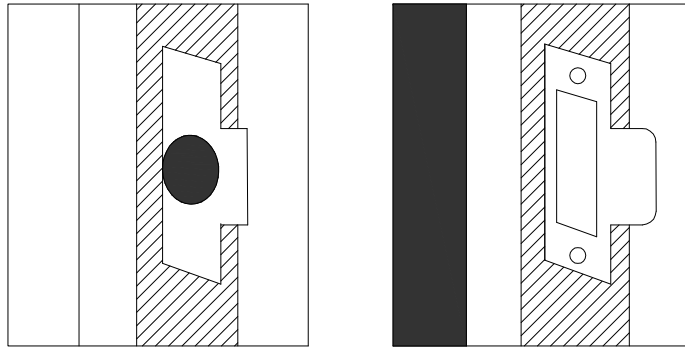

Position the strike plate on the door so that it lines up with the flat of the latchbolt. **NOT THE PLUNGER.**

Make the inner and outer edges of the strike plate and cut a 1mm rebate so that it fits flush with the surface of the door frame.

Drill or cut a recess for latchbolt.

Fit the strike plate using only one wood screw at first to ensure that it is positioned accurately. The latch bolt and not the plunger, should enter the aperture easily, and be held without too much "play". When satisfied secure the strike with the second screw.

N. B. The plunger beside the latchbolt deadlocks the latchbolt and protects it against manipulation. **IT MUST NOT** enter the strike plate aperture when the door is closed

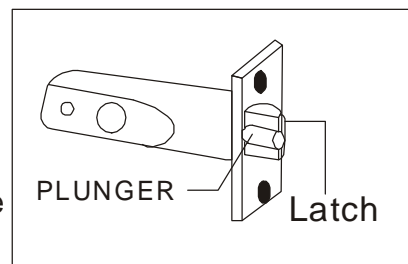

Spring loaded Spindle installation

1. The split is loaded with spring which ensures the split line is in line to the centre line of the latch
2. The spring can be used for door thickness 35-60mm.
3. The spring installed must be inserted to the end of the front plate.

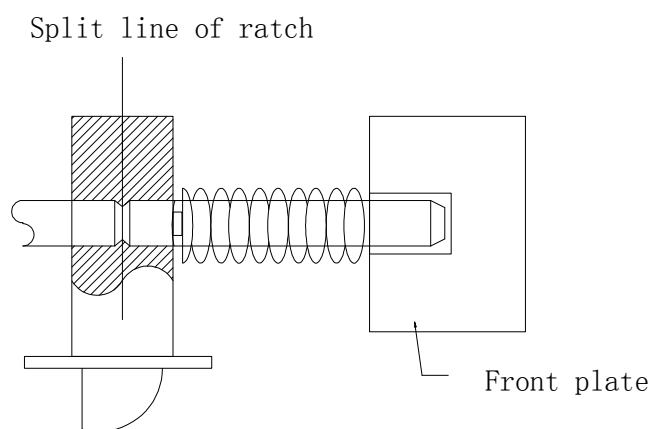

Fixing the lock

1. Cut the fixing bolt length to suit for the door thickness.
2. Put front and back plate with neoprene seals and install to door.
3. Tight up the upper and lower fixing but.

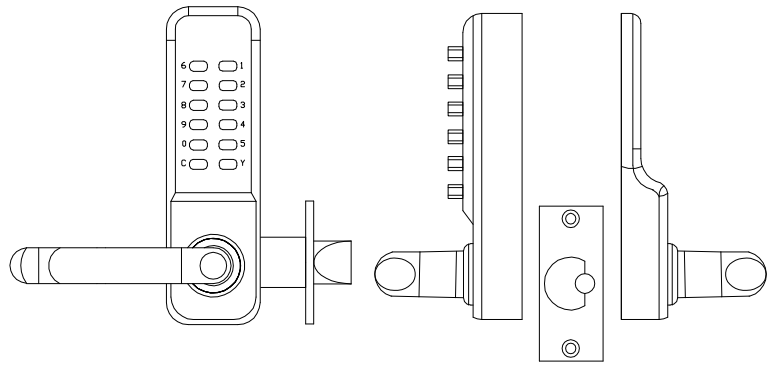

DO NOT CLOSE THE DOOR UNTIL YOU ARE SURE THAT THE CODE WORKS
DO NOT over tighten the fixing bolts as this may cause distortion and lead to poor operation

Guide to Change Entry Code

To change the code simple remove the lock from the door.
On the reverse of the digital lock you will see screw buttons
Which relate to the push buttons on the front of the lock.

All code off

All code on

To set about to operate within the code turn the screw relating to the button so that the dot is facing inward (towards the F) if you wish to take a button out of the code, Turn the screw so that the dot is facing outward (towards G)

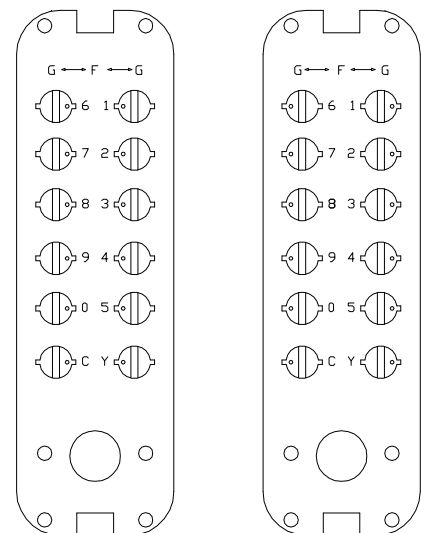

Check the code on the lock to ensure the code works before re-fitting the lock and closing the door.

Important Note:

When the lock is coded, and required to change new code, First of all, turn the coded button in clockwise direction by 180 degrees to cancel the original code. Then set to new code.

