



AirLink GX Series

User Guide



SIERRA
WIRELESS™

4114008
Rev 1

Important Notice

Due to the nature of wireless communications, transmission and reception of data can never be guaranteed. Data may be delayed, corrupted (i.e., have errors) or be totally lost. Although significant delays or losses of data are rare when wireless devices such as the Sierra Wireless AirLink GX Series device are used in a normal manner with a well-constructed network, the Sierra Wireless GX Series device should not be used in situations where failure to transmit or receive data could result in damage of any kind to the user or any other party, including but not limited to personal injury, death, or loss of property. Sierra Wireless accepts no responsibility for damages of any kind resulting from delays or errors in data transmitted or received using the Sierra Wireless AirLink GX Series device, or for failure of the Sierra Wireless AirLink GX Series device to transmit or receive such data.

Safety and Hazards

Do not operate the Sierra Wireless AirLink GX Series device in areas where blasting is in progress, where explosive atmospheres may be present, near medical equipment, near life support equipment, or any equipment which may be susceptible to any form of radio interference. In such areas, the Sierra Wireless GX Series device **MUST BE POWERED OFF**. The Sierra Wireless AirLink GX Series device can transmit signals that could interfere with this equipment.

The driver or operator of any vehicle should not operate the Sierra Wireless AirLink GX Series device while in control of a vehicle. Doing so will detract from the driver or operator's control and operation of that vehicle. In some states and provinces, operating such communications devices while in control of a vehicle is an offence.

In accordance with ANSI/ISA 12.12.1-2012, Section 16 and CSA C22.2 No 213, Section 5.5, the following instructions and warnings apply:

This apparatus is suitable for use in Class I, Division 2, Groups A, B, C and D.

Warning: *EXPLOSION HAZARD – SUBSTITUTION OF COMPONENTS MAY IMPAIR SUITABILITY FOR CLASS I, DIVISION 2.*

Avertissement : *RISQUE D'EXPLOSION – LA SUBSTITUTION DE COMPOSANTS PEUT RENDRE CE MATERIEL INACCEPTABLE POUR LES EMPLACEMENTS DE CLASSE I, DIVISION 2.*

Warning: *EXPLOSION HAZARD – DO NOT DISCONNECT WHILE CIRCUIT IS LIVE UNLESS THE AREA IS KNOWN TO BE NON-HAZARDOUS.*

Avertissement : *RISQUE D'EXPLOSION – NE PAS DEBRANCHER TANT QUE LE CIRCUIT EST SOUS TENSION, A MOINS QU'IL NE S'AGISSE D'UN EMPLACEMENT NON DANGEREUX.*

Warning: *DO NOT USE THE USB CONNECTOR IN A HAZARDOUS AREA.*

Avertissement : *NE PAS UTILISER DE CONNECTEUR USB DANS LES ENVIRONNEMENTS DANGEREUX.*

Limitation of Liability

The information in this manual is subject to change without notice and does not represent a commitment on the part of Sierra Wireless. SIERRA WIRELESS AND ITS AFFILIATES SPECIFICALLY DISCLAIM LIABILITY FOR ANY AND ALL DIRECT, INDIRECT, SPECIAL, GENERAL, INCIDENTAL, CONSEQUENTIAL, PUNITIVE OR EXEMPLARY DAMAGES INCLUDING, BUT NOT LIMITED TO, LOSS OF PROFITS OR REVENUE OR ANTICIPATED PROFITS OR REVENUE ARISING OUT OF THE USE OR INABILITY TO USE ANY SIERRA WIRELESS PRODUCT, EVEN IF SIERRA WIRELESS AND/OR ITS AFFILIATES HAS BEEN ADVISED OF THE POSSIBILITY OF SUCH DAMAGES OR THEY ARE FORESEEABLE OR FOR CLAIMS BY ANY THIRD PARTY.

Notwithstanding the foregoing, in no event shall Sierra Wireless and/or its affiliates aggregate liability arising under or in connection with the Sierra Wireless product, regardless of the number of events, occurrences, or claims giving rise to liability, be in excess of the price paid by the purchaser for the Sierra Wireless product.

Patents

This product may contain technology developed by or for Sierra Wireless Inc.

This product includes technology licensed from QUALCOMM®.

This product is manufactured or sold by Sierra Wireless Inc. or its affiliates under one or more patents licensed from InterDigital Group and MMP Portfolio Licensing.

Copyright

© 2013 Sierra Wireless. All rights reserved.

Trademarks

Sierra Wireless®, AirPrime®, AirLink®, AirVantage® and the Sierra Wireless logo are registered trademarks of Sierra Wireless.

Watcher® is a registered trademark of NETGEAR, Inc., used under license.

Windows® and Windows Vista® are registered trademarks of Microsoft Corporation.

Macintosh® and Mac OS X® are registered trademarks of Apple Inc., registered in the U.S. and other countries.

QUALCOMM® is a registered trademark of QUALCOMM Incorporated. Used under license.

Other trademarks are the property of their respective owners.

Contact Information

International Contact Information

AirLink Sales	airlinksales@sierrawireless.com
AirLink Support*	support@sierrawireless.com
AirLink RMA Repairs*	repairs@sierrawireless.com
AirLink Online Support Knowledgebase	www.sierrawireless.com/Support/SupportCenter
AirLink Software Downloads	www.sierrawireless.com/en/Support/Downloads.aspx
Corporate Web Site	www.sierrawireless.com

* If you have purchased your product from an AirLink Distributor or Reseller, please contact them for first line technical support.

Sierra Wireless Headquarters Contact Information

Sales Headquarters:	Phone:	+1-604-232-1488
	Hours:	8:00 AM to 5:00 PM Pacific Time
	E-mail:	sales@sierrawireless.com
Post:	Sierra Wireless 13811 Wireless Way Richmond, BC Canada V6V 3A4	

Consult our website for up-to-date product descriptions, documentation, application notes, firmware upgrades, troubleshooting tips, and press releases:

www.sierrawireless.com

Revision History

Revision	Date	Summary of changes
1	April 2013	First Release

>> Contents

Introduction to the AirLink GX Series	9
Introduction	9
Description	10
Front Panel	10
Rear Panel	10
X-Cards	12
ALEOS Software	12
ACEmanager	13
ACEview	13
AirVantage Management Service	14
Installation and Startup	15
Tools and Materials Required	15
Installing the SIM Card	16
Mounting the GX Series	17
Vehicle Mounting	18
Antenna Installation	18
Antenna Separation Recommendations	18
Antenna Recommendations	20
Mounting the GPS Antenna	20
Connecting the GX Series	21
Starting the GX Series	21
LED Operation	22
Power Connector Description	24
X-Cards	27
Wi-Fi X-Card	27
I/O X-Card	28
Configuring the AirLink GX Series	31
Connection Ports	31

Configuring with ACEmanager 31

Configuring with AirVantage Management Service 32

Configuring with AT Commands 33

AirLink GX Series Specifications 35

Regulatory Information 39

 Federal Communications Commission Notice (FCC United States) 39

 Notice for Canadian Users 39

 Important Information for North American Users on Radiation Exposure 40

 EU 42

Index..... 45



1: Introduction to the AirLink GX Series

1

This chapter describes the Sierra Wireless AirLink GX Series device, including a description of ALEOS™ embedded software and the AirVantage Management Service (AVMS) device management platform.

Introduction

The AirLink GX Series device is a compact, intelligent and fully-featured cellular gateway that provides real-time wireless capabilities for fixed and mobile applications such as:

- Public safety vehicle deployments
- Public transit systems
- Energy and utilities
- Remote asset monitoring
- Backup broadband connectivity

The AirLink GX Series device has multiple communication ports including serial, Ethernet, and USB ports. The power connector has one digital I/O pin for remote monitoring and control and one ignition sense pin to turn the device on and off and trigger the low power mode.

The AirLink GX Series device is available in the following variants:

- 4G LTE (GX440)
- 3G (GX400)

The AirLink GX Series device has several expansion options to add more capability. The following options are available:

- WiFi (802.11 b/g/n)
- Input/Output (I/O) 15-pin connector which adds:
 - One additional RS-232 port
 - Four additional digital I/O pins
 - Four analog voltage sensing pins

The AirLink GX Series device, when coupled with the rich embedded intelligence provided by the embedded ALEOS software, is the perfect choice for a broad set of machine to machine solutions.

Description

Front Panel

The front panel has the following indicators and controls:



Figure 1-1: GX Series Front Panel

- **LEDs** – These show the device’s operating status. Each LED can be red, green, yellow or off. The LEDs are described in detail in [LED Operation](#) on page 22. They are:
 - **Network** – When green the device is connected to a cellular network with an IP address assigned and a channel acquired
 - **Signal** – When green it is receiving a cellular signal
 - **Activity** – When green, the radio link is active
 - **Power** – When green, the device is connected to power
- **Reset Button** – Pressing this button resets the device. All the LEDs turn solid red after this button is pushed.

Note: Holding the button down for 10 seconds resets the device to its default settings.

Rear Panel

The rear panel has the following connectors and controls:

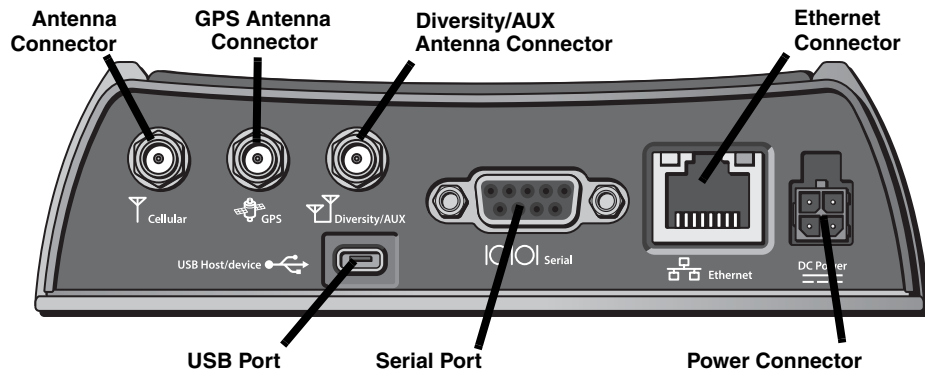

Figure 1-2: GX Series Rear Panel

- **Antenna Connector** – This is the radio's receive and transmit port. The device works with most cellular antennas with an SMA connector.

Note: For more information on antenna connection and use, see [Antenna Installation](#) on page 18.

- **GPS Antenna Connector** – This connects an optional GPS antenna to the device. It works with most antennas that have an SMA connector.

Note: The GPS antenna connector has a bias output and Sierra Wireless recommends that you use an active antenna for better sensitivity.

- **Diversity/AUX Antenna Connector** – This connects an optional auxiliary antenna to the device for backup reception capability. It works with most antennas that have an SMA connector.

Note: The Diversity/AUX connector is receive only, it does not transmit.

- **Ethernet Connector** – This RJ-45 connector connects a standard Ethernet cable to the device. This is used to connect a PC to the device for configuration and diagnostic purposes or attaching Ethernet equipment to the device.
- **Power Connector** – This connects power to the device and provides additional inputs and outputs for the control and monitoring of external devices as well as triggering the low power mode. More information on its operation and how to use it is given in [Power Connector Description](#) on page 24.

There are two types of optional power cables available from Sierra Wireless:

- Cables with an AC adapter that are usually used for indoor, fixed applications where the device runs off line power
- DC cables that are usually used in vehicles or other installations where the device runs off battery power

The device automatically starts when it senses qualified power on the power connector as described in [Starting the GX Series](#) on page 21.

- **Serial Port** – This 9-pin connector provides standard RS-232 communication with a standard straight-through serial cable. It is used to communicate with industrial machines like motors, computers or controllers or for connection to a computer to configure the device with AT commands. It also supports features like TCP PAD and UDP PAD.
- **USB Port** – This Micro AB connector accepts Micro A and Micro B plugs. You can connect a Windows PC to it to monitor and configure the device.
When connected to a PC, it becomes either a:
 - Virtual serial port
 - Virtual Ethernet port

Note: By default it is a virtual Ethernet port.

Windows drivers for this port are available at Sierra Wireless's download web site www.sierrawireless.com/en/Support/Downloads.aspx.

X-Cards

The AirLink GX Series device has several optional, factory-installed, expansion cards (X-Cards) available to add more functions to the basic device. They are configurable with the ALEOS ACEmanager software and more information is available in the ALEOS Configuration User Guide.

The options are:

- **Wi-Fi** – This adds Wi-Fi capability to the device using the 802.11b/g/n standard
- **I/O** – This has a 15-pin connector which adds to the device:
 - One additional RS-232 port
 - Four additional digital I/O pins
 - Four analog voltage sensing pins

For a more complete description of each option, see [X-Cards](#) on page 27.

ALEOS Software

Note: For detailed information on all of the features in ALEOS, see the ALEOS Configuration User Guide. It is available for downloading from the Sierra Wireless web site.

ALEOS, the embedded core technology of the AirLink product line provides:

- Simplified installation, operation and maintenance of any wireless solution
- An always-on, always-aware, intelligent two-way connection for mission-critical applications

ALEOS enables:

- Persistent Network Connectivity
- Over-The-Air (OTA) Upgrades
- Wireless Optimized TCP/IP
- Real-Time Notification
- Real-Time GPS Reporting
- GPS Store and Forward
- Packet Level Diagnostics
- Device Management & Control

Sierra Wireless has three tools for monitoring and configuring AirLink devices. They are:

- **ACEmanager** – A web-based configuration tool for configuring a single AirLink device
- **ACEview** – A Windows application for monitoring the wireless connection status when the PC is connected via Ethernet to the AirLink device
- **AirVantage Management Service (AVMS)** – A cloud based device management service for monitoring and configuring fleets of AirLink devices

Contact your dealer or Sierra Wireless representative for more information.

Download the applications and user guides from the Sierra Wireless AirLink Solutions web site at www.sierrawireless.com/support.

ACEmanager

ACEmanager:

- Simplifies deployment
- Provides extensive monitoring, control and management capabilities
- Configures your device to meet your needs
- Monitors and controls your AirLink device remotely and in real-time
- Is accessed through a web browser connected to the device

See [Configuring with ACEmanager](#) on page 31 to learn how to access ACEmanager.

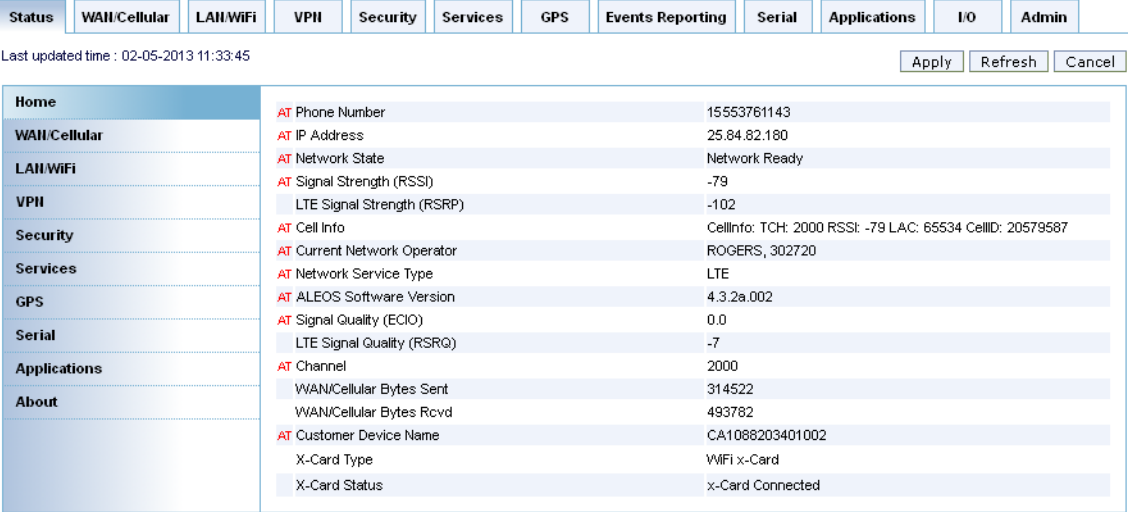

Category	AT Command	Value
Home	AT Phone Number	15553761143
WAN/Cellular	AT IP Address	25.84.82.180
LAN/WiFi	AT Network State	Network Ready
VPII	AT Signal Strength (RSSI)	-79
Security	AT LTE Signal Strength (RSRP)	-102
Services	AT Cell Info	CellInfo: TCH: 2000 RSSI: -79 LAC: 65534 CellID: 20579587
GPS	AT Current Network Operator	ROGERS, 302720
Serial	AT Network Service Type	LTE
Applications	AT ALEOS Software Version	4.3.2a.002
About	AT Signal Quality (ECIO)	0.0
	AT LTE Signal Quality (RSRQ)	-7
	AT Channel	2000
	WAN/Cellular Bytes Sent	314522
	WAN/Cellular Bytes Rcvd	493782
	AT Customer Device Name	CA1088203401002
	X-Card Type	WIFI x-Card
	X-Card Status	x-Card Connected

Figure 1-3: ACEmanager Home Page

ACEview

ACEview is a Windows-based monitoring application for the PC with an easy to read interface.



Figure 1-4: ACEview Screen

Note: ACEview requires the Microsoft .NET Framework v.2.0 and Microsoft Windows XP or later. Obtain the Microsoft .NET Framework from Microsoft at: <http://www.microsoft.com>.

AirVantage Management Service

AirLink devices can be managed with the AirVantage Management Service (AVMS) available from Sierra Wireless. AVMS is a cloud-based application, accessed from your web browser, that provides remote monitoring and configuration for any number of AirLink ALEOS devices from a single computer.

AVMS features include:

- Device management with no software or hardware to buy and no ongoing maintenance required
- Advanced monitoring dashboards and alert notifications ensuring you always know the status of your AirLink devices
- Detailed configuration of all ALEOS parameters, including templates providing batch updates of pre-set configurations across multiple devices
- Over-the-air (OTA) firmware upgrades for all of your AirLink devices with a single operation

To connect with AVMS, see [Configuring with AirVantage Management Service](#) on page 32.

To use AVMS, either call your AirLink reseller or visit: www.sierrawireless.com/en/productsandservices/AirLink/Device_Management.aspx

»» 2: Installation and Startup

This chapter shows you how to connect, install and start the Sierra Wireless AirLink GX Series device. It also describes the front panel LEDs. Also described are the optional X-Cards available from Sierra Wireless that add more functions to the basic device.

Tools and Materials Required

- If needed, a SIM card for your device as provided by your mobile network operator
- If installing a SIM card, a M3, hex-head screwdriver with a 2mm hardened and tempered Hex/Allen key or bit for removing the cover
- Laptop computer with Ethernet cable
- Wireless antenna
- If used, a GPS antenna
- If used, a second wireless antenna
- If used, a straight-through 9-pin connection cable for the RS-232 port
- Power cable, either the DC cable or AC cable ordered from Sierra Wireless or your own custom-made cable

Note: Custom-made cables must incorporate strain relief and use the correct type of power connector to prevent intermittent connection to the device.

Note: The device has a hardened case for use in industrial and extreme environments. If you are installing it in these types of environments, use cables designed and specified for use in these types of environment to avoid cable failure.

Installing the SIM Card

If your mobile network operator requires it, insert a SIM card into the device before installation or connecting any external equipment or power to the device.

1) Remove the four screws attaching the cover.

NOTE: When re-attaching the screws, torque them to 5 in-lb (0.6 N-m).

2) Remove the cover.

3) Slide the SIM card into the connector.

Note the direction of notched corner of SIM card for proper alignment.

4) Reattach the cover.

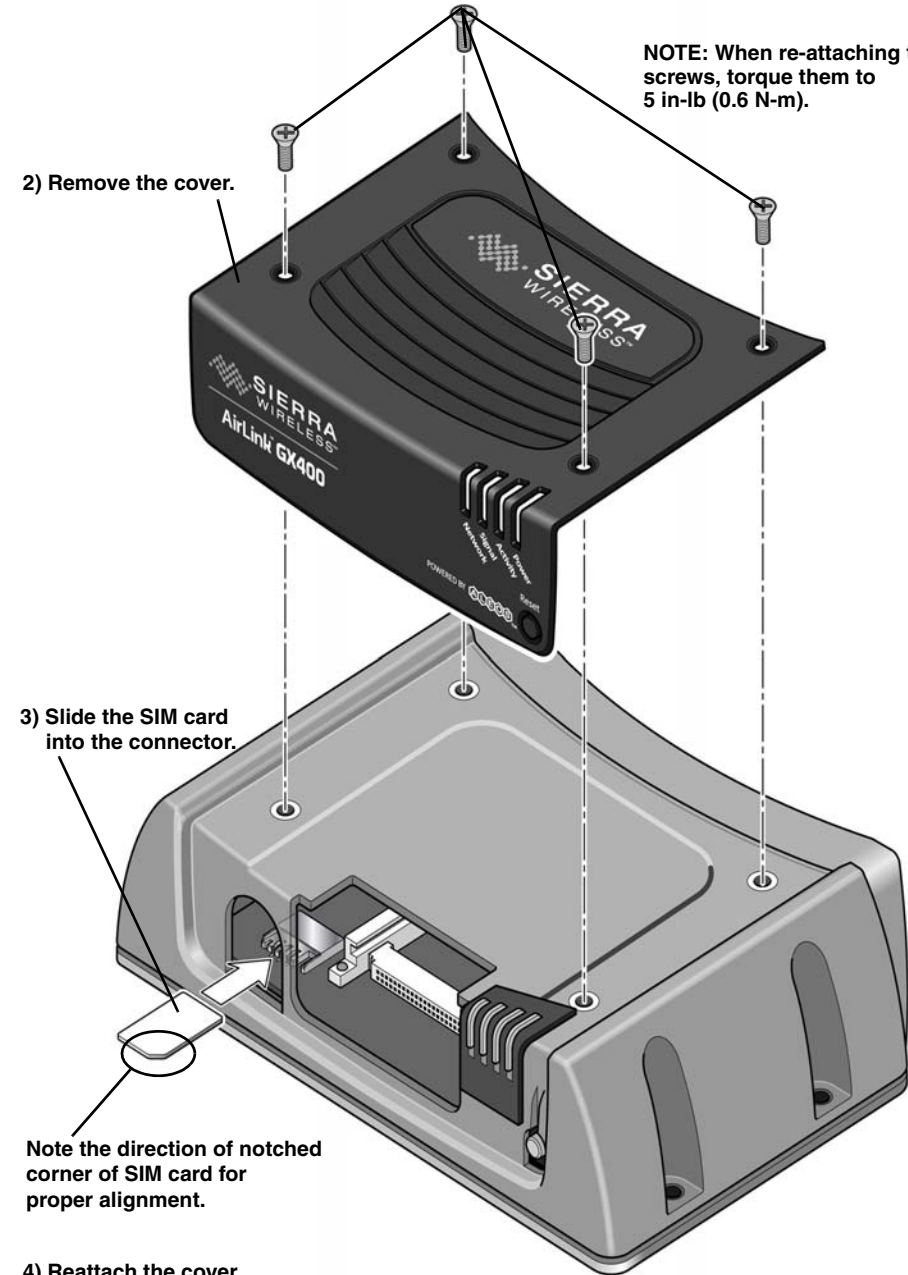

Figure 2-1: SIM Card Installation

Note: If you see “No SIM or Unexpected SIM Status” in ACEmanager’s Network State section of the Status > Home tabs, the card may be missing or installed incorrectly.

Last updated time : 12-21-2012 13:19:41		Apply	Ref
Home	AT Phone Number	+16044482407	
WAN/Cellular	AT IP Address	0.0.0.0	
LAN	AT Network State	No SIM or Unexpected SIM Status	
VPN	AT Signal Strength (RSSI)	-110	
	AT Cell Info	CellInfo: RSSI: -110	

Figure 2-2: SIM Card Missing Message in ACEmanager

Mounting the GX Series

Warning: *This device is not intended for use close to the human body. Antennas should be at least 8 inches (20 cm) away from the operator.*

Note: The device has a hardened case for use in industrial and extreme environments. If you are installing it in these types of environments, use cables designed and specified for use in these types of environment to avoid cable failure.

Mount the device where:

- There is easy access to the cables
- Cables are not bent, constricted, close to high amperages or exposed to extreme temperatures
- The front panel LEDs are easily visible
- There is adequate airflow
- It is kept free from direct exposure to the elements, such as sun, rain, dust, etc.

Note: Sierra Wireless recommends that the device’s case or the mounting bracket be connected to ground, which can be the battery or power source negative terminal. This provides protection from electrostatic discharges. Do this by connecting a grounding strap under one of the mounting screws.

In addition to the four mounting holes on the side of the device's body, there are four holes on the bottom plate to attach the device to a mounting surface.

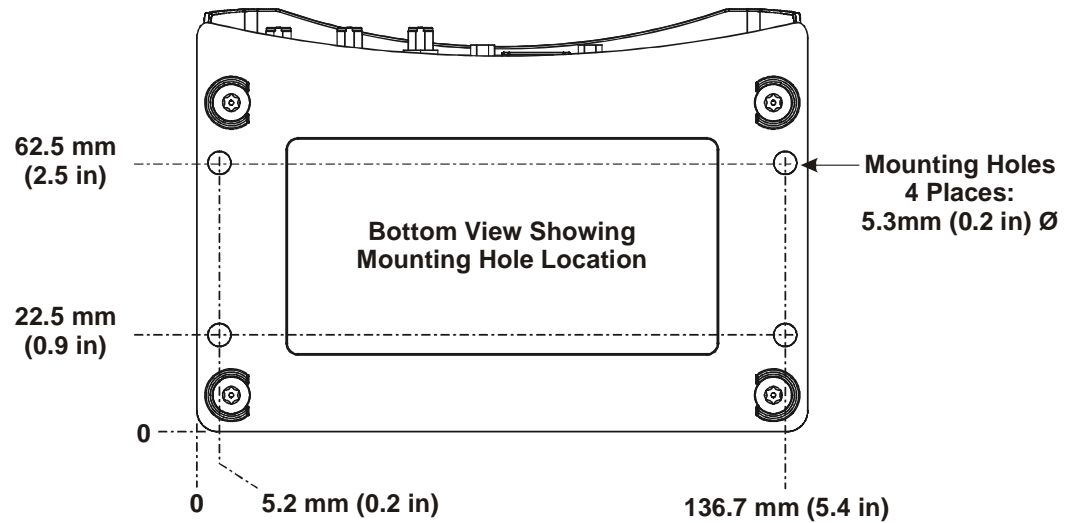

Figure 2-3: GX Series Bottom Plate and Mounting Holes

Vehicle Mounting

When installing the device in a vehicle:

- Keep it out of direct exposure to the weather (sun, rain, etc.). The best locations are in places like a car trunk or in a container behind the seats.
- Place it where it will not be hit or come into contact with people, cargo, tools, equipment, etc.

Antenna Installation

Inadequate antenna separation between the transmit and diversity antennas creates unwanted interactions. This can cause reductions in:

- Antenna efficiency
- Transmit power
- Receiver sensitivity
- Data throughput
- Radio front-end life span

Antenna Separation Recommendations

- The antennas should be separated so that there is at least 10dB isolation over the entire operating frequency range.
- The separation should be at least 0.25 wavelength (preferably greater than 0.5 wavelength) of the lowest operating frequency.

Note: If the separation is less than 0.25 wavelength, increase it to at least 0.25 wavelength (preferably greater than 0.5 wavelength) of the lowest operating frequency.

- In confined spaces, a separation of 0.15 wavelength is possible, but this will result in reduced network coverage.
- The recommended separation is only an approximate value for monopole or dipole type antennas.

Sierra Wireless recommends the following antenna separation:

Table 2-1: Recommended Antenna Separation

Service	Frequency (Hz)	Wavelength (mm)	Best Separation (mm)	Good Separation (mm)	Reduced Service Separation (mm)
LTE	700	428	214	107	64
LTE	800	375	187	94	56
LTE	900	333	167	83	50
LTE	1800	167	83	42	25
LTE	2100	143	71	36	21
LTE	2600	115	58	29	17
WCDMA	850	353	176	88	53
WCDMA	900	333	167	83	50
WCDMA	1900	158	79	39	24
WCDMA	2100	143	71	36	21
CDMA/EV-DO	800	375	187	94	56
CDMA/EV-DO	1900	158	79	39	24
GSM/GPRS/EDGE	850	353	176	88	53
GSM/GPRS/EDGE	900	333	167	83	50
GSM/GPRS/EDGE	1800	167	83	42	25
GSM/GPRS/EDGE	1900	158	79	39	24

Table 2-2: Separation Examples for Carrier-Specific Bands

Service	Band	Carrier	Country	Min Frequency (Hz)	Wavelength (mm)	Best Separation (mm)	Good Separation (mm)	Reduced Service Separation (mm)
LTE	13	Verizon	US	746	401.8665657	201	100	60
LTE	17	AT&T	US	704	425.8415597	213	106	64
LTE	4	Bell/Rogers/Telus	Canada	1710	175.3172269	88	44	26

Antenna Recommendations

Note: Do not remove the diversity antenna. The diversity antenna helps the device achieve the maximum network coverage. The device works without one installed, but with reduced network coverage.

Note: If the antennas are located far away from the device, keep the cables as short as possible to prevent the loss of antenna gain.

Warning: The antenna should not exceed the maximum gain specified in [Maximum Antenna Gain \(Gain D'antenne Maximal\)](#) on page 41. In more complex installations (such as those requiring long lengths of cable and/or multiple connections), you must follow the maximum dBi gain guidelines specified by the radio communications regulations of the Federal Communications Commission (FCC) or Industry Canada or your country's regulatory body (if used outside the US). Also see [Important Information for North American Users on Radiation Exposure](#) on page 40 for more information.

Mounting the GPS Antenna

Mount the antenna where it has a good view of the sky such as on the roof, the dashboard or the rear panel. It should see at least 90° of the sky.

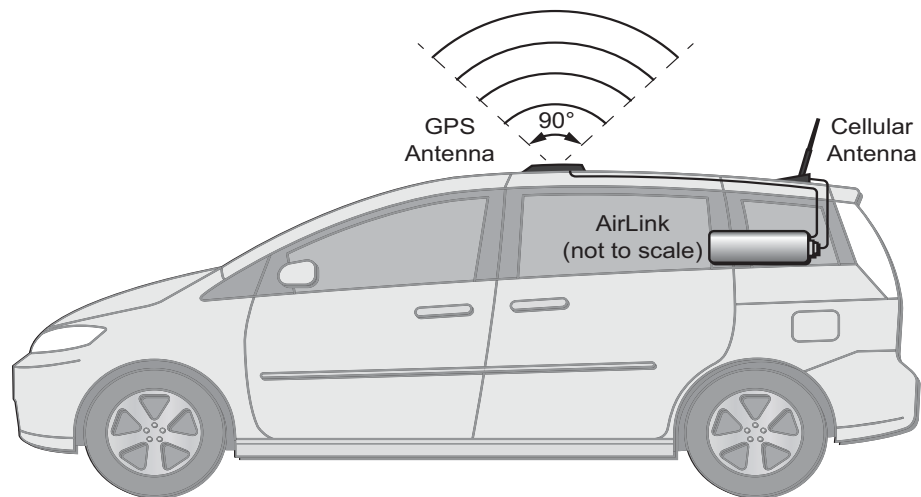

Mounting the GPS Antenna

Connecting the GX Series

Note: Route cables so that they are protected from damage and will not be snagged or pulled on. There should be no binding or sharp corners in the cable routing. Excess cabling should be bundled and tied off. Make sure that the cables are secured so that their weight will not loosen the connector from the device over time.

1. Connect the RF antenna to the antenna connector.
 2. If used, connect the GPS antenna to the GPS antenna connector.
 3. If used, connect an RF antenna to the Diversity/AUX antenna connector.
 4. Attach a laptop to the device with the Ethernet cable.
 5. If used, attach a device or computer to the RS-232 port and/or the USB port.
-

Note: Before proceeding, turn off the power going to the device.

6. Connect the power cable to the device, and if used, to the external devices to be controlled/monitored.
-

Note: For details about the power connector, see [Power Connector Description](#) on page 24. The battery connector cable should be no longer than 10 feet (3 meters).

7. Turn on the power.
The device starts automatically as soon as it receives power as described in [Starting the GX Series](#) on page 21.

Starting the GX Series

Upon receiving power, the device automatically starts as shown by the flashing LEDs. If it does not turn on, see that the:

- Power connector is plugged in
- Power cable is connected to power (line or battery power)
- Power is turned on or that the battery is fully charged
- Ignition Sense (pin 3) is connected to the battery or power source (see [Power Connector Description](#) on page 24 for details)

After the initial power up, to see if the device is properly connected and operating correctly:

1. In the laptop connected to the device, open a web browser.
 2. In the browser's address bar, enter the IP address:
http://192.168.13.31:9191.
-

Note: It may take a minute or two for the device to respond after the first power up.

The ACEmanager login screen appears.

3. Enter your user name and password. The administrator user name is **user** and password is **12345**.

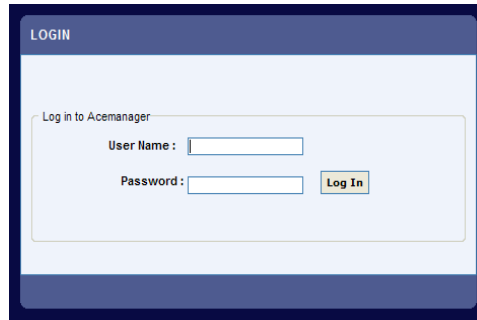

Figure 2-4: ACEmanager Login Screen

The ACEmanager homepage appears.

Home	AT Phone Number	15553761143
WAN/Cellular	AT IP Address	25.84.82.180
LAN/WiFi	AT Network State	Network Ready
VPN	AT Signal Strength (RSSI)	-79
	LTE Signal Strength (RSRP)	-102
Security	AT Cell Info	CellInfo: TCH: 2000 RSSI: -79 LAC: 65534 CellID: 20579587
Services	AT Current Network Operator	ROGERS, 302720
	AT Network Service Type	LTE
GPS	AT ALEOS Software Version	4.3.2a.002
Serial	AT Signal Quality (ECIO)	0.0
	LTE Signal Quality (RSRQ)	-7
Applications	AT Channel	2000
About	WAN/Cellular Bytes Sent	314522
	WAN/Cellular Bytes Rcvd	493782
	AT Customer Device Name	CA1088203401002
	X-Card Type	WiFi x-Card
	X-Card Status	x-Card Connected

Figure 2-5: ACEmanager Homepage

LED Operation

LED Colors

The four front panel LEDs show the status of various items and can be used as a troubleshooting aid. They are multi-colored:

- **Off** – No activity
- **Red** – Not functional
- **Yellow** – Limited functionality
- **Green** – Fully functional
- **Blinking** – Shows altered or reduced functionality

Note: When all of the LEDs are solid red, the reset button has been pushed and the device is restarting.

Power LED

This monitors the input power or shows if the device sees a GPS signal.

- **Off** – No power or input voltage $\geq 36\text{VDC}$ or $\leq 9\text{VDC}$
- **Red** – The device is not operational (failure or in low power mode)
- **Yellow** – The device is entering low power mode or system low level boot
- **Green** – The device is connected to nominal power and is operating normally
- **Green with a momentary yellow flash** – The device has a GPS fix

Activity LED

This shows the radio's activity.

- **Off** – The LED's normal appearance
- **Flashing green** – The radio is transmitting or receiving

Signal LED

This shows the cellular network's signal level.

- **Flashing red** – No signal is present (RSSI > -110 dBm)
- **Red** – A bad signal is present (RSSI > -100 dBm or ≤ -110 dBm)
- **Yellow** – A marginal signal is present (RSSI > -85 dBm or ≤ -100 dBm)
- **Green** – A good signal is present (RSSI ≤ -85 dBm)

Network LED

This monitors the cellular network.

- **Red** – No cellular network is present or the device is in radio passthru mode (There is no network coverage at the location)
- **Flashing red** – The device is attempting to connect to the cellular network
- **Yellow** – The cellular network is found and the device is connecting
- **Flashing yellow** – The cellular network is unavailable (The device was unable to authenticate on the network)
- **Green** – Connected to the cellular network
- **Flashing Green** – The device is roaming

Power Connector Description

The GX Series device’s power connector is a four pin connector that has:

- Two pins connecting DC voltage to the device
- Two pins providing additional monitoring and control functions

This section has information to help you plan your device’s connection and configuration.

The connector’s pin diagram is shown below. It also shows the colors of the wires used on the DC power cable you can order from Sierra Wireless.

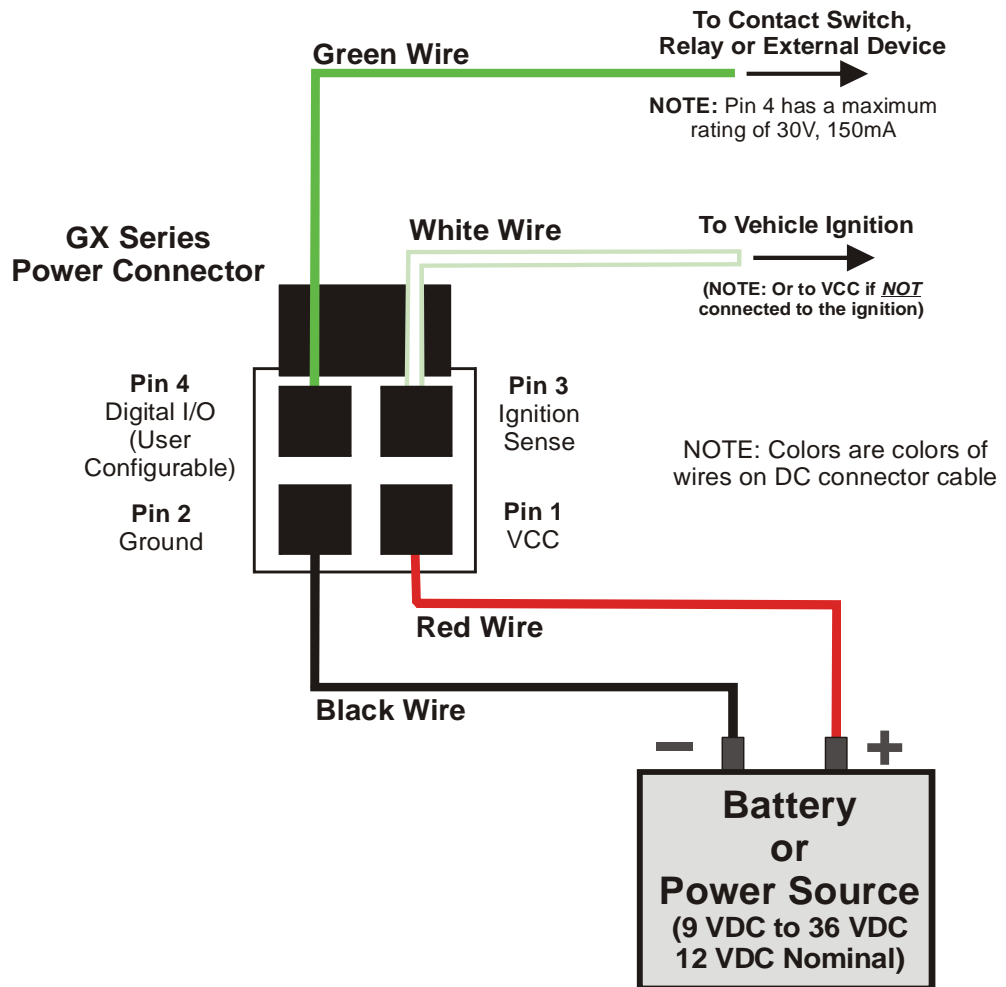

Figure 2-6: GX Series device Power Connector Pin Diagram

Pins 1 and 2

- **Pin 1** – VCC; Connect to +12VDC (nominal) (red wire on DC cable)
- **Pin 2** – Ground; Connect to ground (black wire on DC cable)

Pin 3

This pin is the ignition sense pin (white wire on DC cable). The voltage level present on this pin turns the device on and off.

*Note: If you do not connect this pin to the ignition, you **MUST** connect it to the positive terminal of your power supply or battery. The device looks for a qualified voltage on this pin as part of the power up sequence (9–36VDC). If one is not present, the device will not turn on. If you are using a Sierra Wireless AC cable, the connection is inside the cable.*

There are several typical connection options for this pin:

Option 1 – If you want the device turned on and off when the engine is turned on and off:

- Connect pin 3 to the ignition
- In ALEOS, disable the Low Power Mode (Default setting is disabled)

Option 2 – If you power the device from the engine's battery and you do not want the device to drain it when the engine is turned off:

- Connect pin 3 to the ignition
- In ALEOS, enable the Low Power Mode and set a time delay

When the ignition is turned off, the device operates at full power for the programmed time delay. When it expires, the device switches to Low Power Mode (consumes 35mA or less). The device resumes normal operation when the ignition is turned on.

Option 3 – If you want the device to switch into low power mode when the engine battery voltage drops below a certain value:

- Connect pin 3 to pin 1
- In ALEOS, configure the Low Power Mode with a voltage level threshold

The device operates normally until the battery voltage drops below the threshold value, triggering the Low Power Mode. The device resumes normal operation when the battery voltage rises above the threshold value.

Option 4 – If you use a separate battery other than the engine's for device power, (such as in an ambulance or other application that has a stand-alone battery power system) but it isn't connected to an ignition or an on/off switch, and you do not want the battery drained:

- Connect pin 3 to pin 1
- In ALEOS, configure the Low Power Mode with a voltage level threshold

The device operates normally until the battery voltage drops below the threshold value, triggering the Low Power Mode. The device resumes normal operation when the battery voltage rises above the threshold value.

Option 5 – If you have an installation where the device uses line power such as in a store or a remote site where power saving isn't needed:

- Use the Sierra Wireless AC adapter or connect pin 3 to pin 1
- In ALEOS, disable the Low Power Mode. (Default setting is disabled)

The device is on for as long as the power is on.

Note: For details on how to use ALEOS, see the ALEOS Configuration User Guide. It is available for downloading from the Sierra Wireless support web site.

Pin 4

This pin is a digital input/output (green wire on DC cable).

Pin 4 either:

- Monitors inputs and outputs
- Drives a relay

It has a maximum rating of 30V and 150mA sink current. The pin is user programmed. Configuration instructions along with other information on how to use it is given in the ALEOS Configuration User Guide.

One way to use pin 4 is with events reporting. In ALEOS you:

1. Create an **Event**.

This triggers the device to act when it sees a specific input. For example, you can tell the device to do something when the pin (called digital input 1 in ALEOS) sees a digital 1. This could be when a door is opened, activating a switch attached to it.

2. Specify an **Action**.

These are instructions the device performs when it sees an event. For example, an email could be sent to security, saying the door is open, giving the time, location and other information.

There are several typical uses for Pin 4:

- As a **digital input**, it monitors a switch, using its opening or closing to record events or monitoring external voltages of up to 30VDC. For example, you could use it to measure the voltage on a 24VDC light bulb and have the device react when it turns on.

When the switch, or input voltage is:

- **Open (2.2VDC to 30VDC)** – It is read as a digital input=1
- **Closed (-0.5 to 1.2VDC)** – It is read as a digital input=0

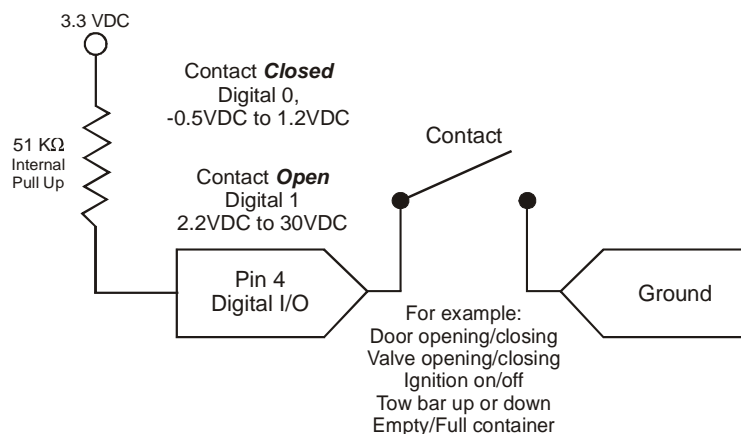

Figure 2-7: Digital Input Operation

- As a **digital output**, it can trigger an alarm, siren, door lock or opens a valve or a switch. Pin 4 is an open collector transistor output normally at 3.3VDC. When triggered, it is pulled to ground. The initial state of the digital output when the device is rebooted is configurable in ALEOS.

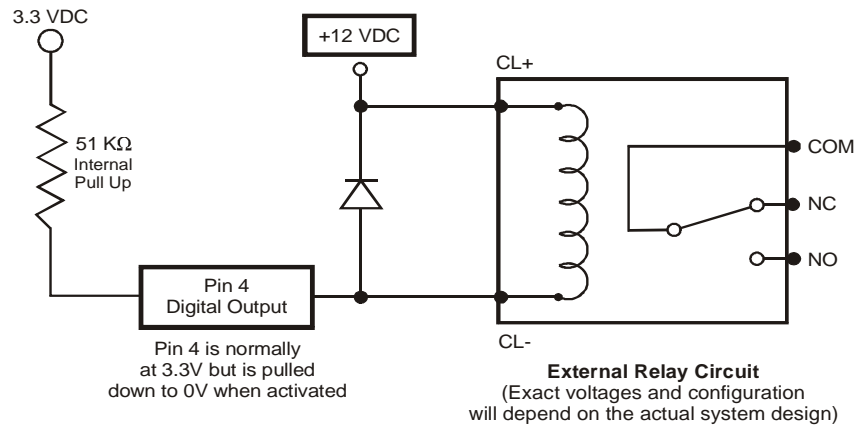

Figure 2-8: Digital Output Operation

X-Cards

The AirLink GX Series has several optional, factory-installed, expansion cards (X-Cards) available to add more functions to the basic device. They are configurable with the ALEOS ACEmanager software and more information is available in the ALEOS Configuration User Guide, which is available for downloading from the Sierra Wireless web site.

The available X-Cards are:

- Wi-Fi
- I/O

If you have an X-Card card installed on your device, its type and status is shown on the ALEOS home page (Status > Home).

WAN/Cellular Bytes Rcvd	493782
AT Customer Device Name	CA1088203401002
X-Card Type	WiFi x-Card
X-Card Status	x-Card Connected

Figure 2-9: X-Card Installed Indicator on ALEOS Home Page

Wi-Fi X-Card

This card adds Wi-Fi capacity to the device using the 802.11b/g/n standard. It has the following modes:

- Client Mode** where a GX device uses a Wi-Fi client connection to connect to an access point, rather than acting as an access point (AP)
- Access Point Mode** where the device acts as an AP

- **Both** (AP + Client Mode) where the device can act as an AP and also use a Wi-Fi Client connection to connect to an AP

The GX Series device connects as a client to a configured AP whenever the AP is available. When the AP is not available, it connects to 3G, all the while the device acts as a AP to W-Fi clients connected to the GX.

See the ALEOS Configuration User Guide for details on Wi-Fi set up and use.

I/O X-Card

This card uses a 15-pin connector to add to the basic device:

- One additional RS-232 communication port
- Four additional digital I/O pins
- Four analog voltage sensing pins

See the ALEOS Configuration User Guide for details on I/O set up and use.

I/O X-Card 15-Pin Connector Description

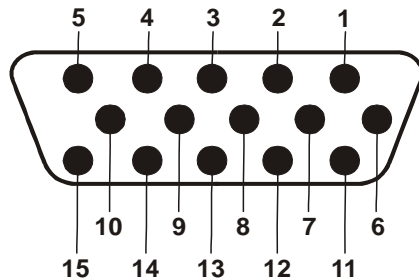

Figure 2-10: I/O X-Card 15-pin Connector Pin Diagram

Table 2-3: I/O 15-Pin Connector Pin Description

Pin	Description	Pin	Description
1	RS-232 TXD Output	9	Reserved for future use
2	RS-232 RTS Output	10	Ground
3	Digital I/O 2	11	Digital I/O 3
4	Digital I/O 4	12	Digital I/O 5
5	RS-232 RXD Input	13	Reserved for future use
6	RS-232 CTS Input	14	Analog Input 1
7	Analog Input 2	15	Analog Input 3
8	Analog Input 4	NOTE: This is not a VGA connector	

I/O X-Card RS-232 Port

Pins 1, 2, 5 and 6 plus the ground on pin 10 provide 4-wire RS-232 communication. It also supports features like AT, TCP PAD and UDP PAD.

Note: There is no connection for RI, DCD, DTR or DSR.

I/O X-Card Digital I/O Input Pins

Pins 3, 4, 11 and 12 are programmed in ALEOS to monitor inputs, respond to certain types of events or trigger a digital output. They behave exactly like the Digital I/O (pin 4) on the power connector as described in [Power Connector Description](#) on page 24.

Note: Pin 4 on the power connector is called Digital Input 1 in the ACEmanager screen.

Pins 3, 4, 11 and 12 (Digital inputs 2 to 5) have a voltage of 2.8VDC when it is set to high in ALEOS. A voltage on the pins of:

- 2.2VDC to 30VDC=logic 1
- -0.5VDC to 1.3VDC=logic 0

I/O X-Card Analog Voltage Input Pins

Pins 7, 8, 14 and 15 are analog voltage sensing pins programmed in ALEOS to look for specific events. The pins have a maximum rating of 30V, 200uA.

These pins detect inputs of 0–30VDC across the pins to ground. When used with a converter to transform values into voltages, the pins can monitor measurements like temperatures, pressures or the volume of liquid in a container. ALEOS can transform these voltages into meaningful values. In ALEOS, events reporting tells the device to perform an action when a specified voltage is detected.

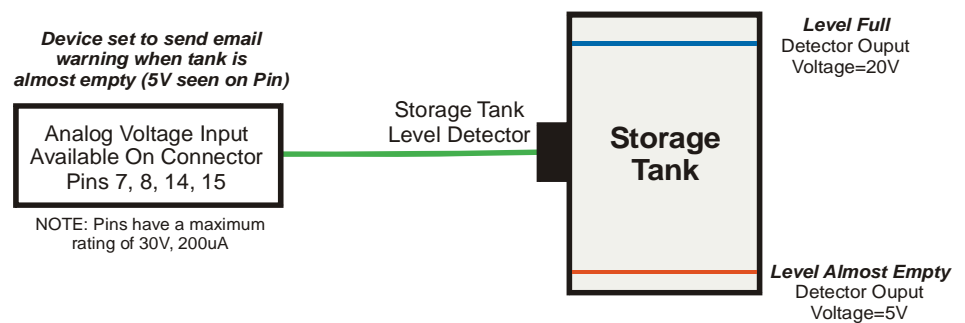

Figure 2-11: I/O X-Card Analog Voltage Input Operation



3: Configuring the AirLink GX Series

3

This chapter shows you how to communicate with and configure the Sierra Wireless AirLink GX Series device.

Connection Ports

You can connect to the device's:

- USB port (Micro AB)
- Ethernet port (RJ-45)
- Serial port (9-pin RS-232)

USB Port

The USB port can be either a:

- Virtual Ethernet port
- Virtual serial port

Drivers must be installed on the PC for it to work in either mode. They are available for download at <http://www.sierrawireless.com/en/Support/Downloads.aspx>.

We recommend you:

- Use a USB 2.0 cable
- Connect directly to your computer for best throughput

Configuring with ACEmanager

Note: For all of the configurable features available in ALEOS, see the ALEOS Configuration User Guide. It is available for downloading from the Sierra Wireless support web site.

AirLink devices are highly configurable when using the embedded ALEOS software. ACEmanager is a free utility included with every AirLink device. To access it:

1. Connect a laptop to the device with an Ethernet cable.
2. Start a web browser.
3. In the browser's address bar, enter the IP address:
http://192.168.13.31:9191.
4. The login screen appears. Enter your name and password.

*Note: The administrator user name is **user** and the password is **12345**.*

The ACEmanager home page appears. From it you can access all of ALEOS's configurable features.

Status	WAN/Cellular	LAN/WiFi	VPII	Security	Services	GPS	Events Reporting	Serial	Applications	I/O	Admin
Last updated time : 02-05-2013 11:33:45											
<input type="button" value="Apply"/> <input type="button" value="Refresh"/> <input type="button" value="Cancel"/>											
Home	AT Phone Number 15553761143										
WAN/Cellular	AT IP Address 25.84.82.190										
LAN/WiFi	AT Network State Network Ready										
VPII	AT Signal Strength (RSSI) -79										
Security	LTE Signal Strength (RSRP) -102										
Services	AT Cell Info CellInfo: TCH: 2000 RSSI: -79 LAC: 65534 CellID: 20579587										
GPS	AT Current Network Operator ROGERS, 302720										
Serial	AT Network Service Type LTE										
Applications	AT ALEOS Software Version 4.3.2a.002										
About	AT Signal Quality (ECIO) 0.0										
	LTE Signal Quality (RSRQ) -7										
	AT Channel 2000										
	WAN/Cellular Bytes Sent 314522										
	WAN/Cellular Bytes Rcvd 493782										
	AT Customer Device Name CA1088203401002										
	X-Card Type WFI x-Card										
	X-Card Status x-Card Connected										

Figure 3-1: ACEmanager Home Page

Configuring with AirVantage Management Service

AirLink devices can be configured with the AirVantage Management Service (AVMS) from Sierra Wireless. AVMS is a cloud-based application, available from your web browser, that provides remote monitoring and configuration for any number of your AirLink ALEOS devices.

For more information on AVMS, go to http://www.sierrawireless.com/en/productsandservices/AirVantage/Management_Service.aspx

To access AirVantage:

1. Connect a laptop to the device with an Ethernet cable.
2. Start a web browser.
3. In the browser's address bar, enter the IP address:
 - <http://na.airvantage.net/start> (for North American customers)
 - <http://airvantage.net> (for European customers)
 The AirVantage login screen appears.
4. Enter your email address and AirVantage password and click **Log In**.

The AirVantage start page appears. You can now manage your device through AirVantage.

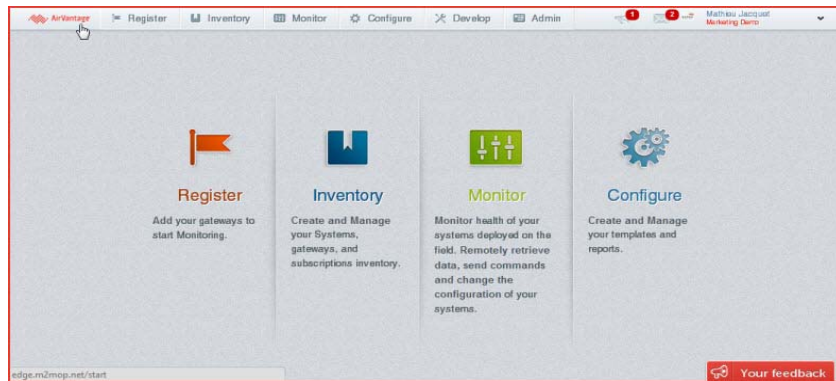

Figure 3-2: AirVantage Start Page

Configuring with AT Commands

The device can be commanded and configured with AT commands. All the commands are listed in the ALEOS Configuration User Guide.

In ACEmanager, mouse over a red AT to the left of a listing to see a popup showing the AT command for that item.

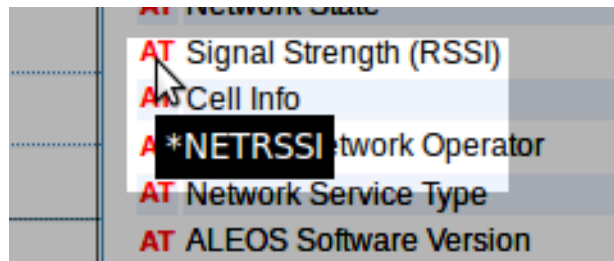

Figure 3-3: Mouse over for AT command (Signal Strength Shown)

- Most AT commands are prefaced with AT. Exceptions are noted in the ALEOS Configuration User Guide.
- The acceptable format and parameters are listed with each command in the ALEOS Configuration User Guide.
- If you enter a recognized AT command, the device responds with “OK.” If the command is wrong, the device responds with “ERROR” or “Unsupported.”

4: AirLink GX Series Specifications

4G LTE Models (GX 440)

- LTE/EV-DO (Verizon Wireless)
LTE Band 13 with fallback to EV-DO Rev A 800/1900 MHz
- LTE/HSPA+ (AT&T, Canada)
LTE Band 17/AWS with fallback to HSPA+ 850/1900/2100 MHz

3G Models (GX 400)

- EV-DO Rev A 800/1900 MHz
- HSPA+ 850/900/1900/2100 MHz

GPS Technology

- Protocols: NMEA 0183 V3.0, TAIP, RAP
- 4G LTE Models:
 - Acquisition time: 2 sec hot start
 - Accuracy: < 2 m (50%), < 5 m (90%)
 - Tracking sensitivity: -161 dBm
- 3G Models:
 - Acquisition time: 9 sec hot start
 - Accuracy: < 3 m (50%), < 8 m (90%)
 - Tracking sensitivity: -152 dBm

Protocols

- Network: TCP/IP, UDP/IP, DNS
- Routing: NAT, Host Port Routing, DHCP, PPPoE, VLAN, VRRP
- Application: SMS, Telnet/SSH, SMTP, SNMP, SNTTP
- Serial: TCP/UDP PAD Mode, Modbus (ASCII, RTU, Variable), PPP

Events Reporting

- Event Types:
 - Digital input
 - GPS/AVL
 - Network parameters
 - Data usage
 - Timer
 - Power
 - Device temperature
- Report/Action Types:
 - SMS

- Email
- SNMP trap
- Relay output
- GPS RAP report
- Events protocol message to server

VPN/Security

- IPsec, SSL, and GRE VPN client
- Up to 5 VPN tunnels
- IKE encryption
- Port forwarding and DMZ
- Port filtering
- Trusted IP
- MAC address filtering

Device Management

- AirVantage™ Management Service cloud-based device management application
- ACEManager™ device configuration utility

ALEOS Application Framework

- Lua language coding platform
- Remote application management
- Eclipse-based IDE
- Integrated real-time debugging

Input/Output

- Configurable I/O on power connector
- Input ON voltage: 3.3VDC to 30VDC
- Input OFF voltage: 0VDC to 1.2VDC
- Output maximum switching capability 200mA @ 30VDC

Environmental

- Operating temperature: -30°C to +70°C (-22°F to +158°F)
- Storage temperature: -40°C to +85°C (-40°F to +185°F)
- Humidity: 90% RH @ 60°C (140°F)
- Military Spec MIL-STD-810F conformance to thermal, mechanical shock and humidity

Host Interfaces

- 10/100 Base-T RJ-45 Ethernet
- RS-232 Serial port
- USB V2.0 Micro-AB connector
- 3 SMA antenna connectors (RF, GPS, Rx Diversity)
- Support for active antenna

Wi-Fi Expansion

- IEEE 802.11b/g/n
- Both hotspot and client capability
- Up to 8 simultaneous Wi-Fi connections
- Security: WEP, WPA/WPA2 (AES)
- SMA antenna connector

I/O Expansion

- 4 Configurable digital I/O
- 4 Analog inputs
 - Range of 0 to 30V
 - 10-Bit resolution
- RS-232 Serial port

Certifications

- PTCRB, R&TTE
- FCC, Industry Canada
- CE, E-Mark
- RoHS Compliant, Class 1 Div 2
- Approved for deployment by Verizon Wireless, AT&T, Sprint, Rogers, Bell, Telus, Telstra
- Consult the web site for a complete list of operator approvals

Mechanical Specifications

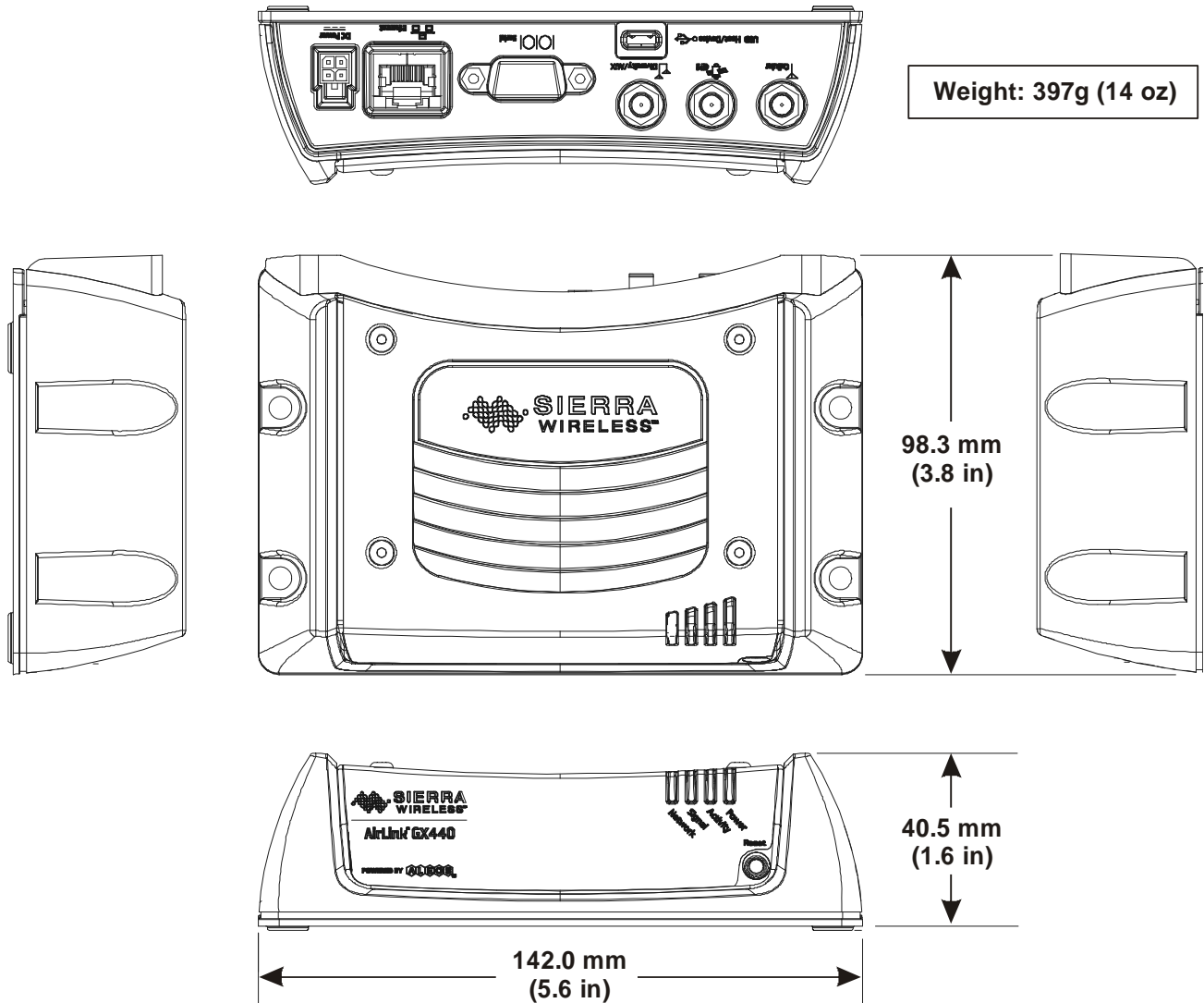

Figure 4-1: AirLink GX Series Mechanical Specifications (Standard Device Shown)

The power connector and the connector that fits it are:

- Tyco male 2x2P PH:3.0mm Housing, 250V, 5A MAX, PA66 Black UL94V-0, p/n 794606-1
- Tyco female crimp terminal AWG 20-24, 250V, 5A MAX, Phosphor bronze, Tin plated, p/n 794617-4

Federal Communications Commission Notice (FCC United States)

Electronic devices, including computers and wireless devices, generate RF energy incidental to their intended function and are therefore subject to FCC rule and regulations. This equipment has been tested to, and found to be within the acceptable limits for a Class A digital device, pursuant to part 15 of the FCC Rules.

This equipment generates radio frequency energy and is designed for use in accordance with the manufacturer's user manual. However, there is no guarantee that interference will not occur in any particular installation.

If this equipment causes harmful interference to radio or television reception, which can be determined by turning the equipment off and on, you are encouraged to try to correct the interference by one or more of the following measures:

- Reorient or relocate the receiving antenna.
- Increase the separation between the equipment and the receiver.
- Connect the equipment into an outlet on a circuit different from that to which the receiver is connected.
- Consult the dealer or an experienced radio/television technician for help.

This device complies with Part 15 of the Federal Communications Commission (FCC) Rules. Operation is subject to the following two conditions:

1. This device may not cause harmful interference.
2. This device must accept any interference.

Warning: *Changes or modifications to this device not expressly approved by Sierra Wireless could void the user's authority to operate this equipment.*

Notice for Canadian Users

This Class A digital apparatus complies with ICES-003.

Industry Canada Notice

This Class A device complies with ICES-003 and RSS-210 of the Industry Canada rules. Operation is subject to the following two conditions:

1. This device may not cause harmful interference, and

2. This device must accept any interference received, including interference that may cause undesired operation of the device.

Avis d'Industrie Canada

Cet appareillage numérique de la Classe A est conforme aux normes ICES-003 et RSS-210 du Canada. L'utilisation de ce dispositif est autorisée seulement aux conditions suivantes :

1. Il ne doit pas produire de brouillage et
2. Il doit accepter tout brouillage radioélectrique reçu, même si ce brouillage est susceptible de compromettre le fonctionnement du dispositif.

Important Information for North American Users on Radiation Exposure

This equipment complies with FCC/IC radiation exposure limits set forth for an uncontrolled environment. This equipment should be installed and operated with a minimum distance of 20 cm between the radiator and the user's body.

Warning: *This product is only to be installed by qualified personnel.*

To comply with FCC/IC regulations limited both maximum RF output power and human exposure to RF radiation, maximum antenna gain must not exceed the values given in the tables in [Maximum Antenna Gain \(Gain D'antenne Maximal\)](#) on page 41.

Warning: *A minimum separation distance of 20 cm must be maintained between the antenna(s) used for this transmitter and all personnel.*

Informations Importantes Pour les Utilisateurs Nord-Américains sur L'exposition aux Radiations

Ce matériel est conforme aux limites établies par FCC/IC en matière d'exposition aux radiofréquences dans un environnement non contrôlé. Ce matériel doit être installé et utilisé à une distance d'au moins 20 cm entre l'antenne et le corps de l'utilisateur.

Avertissement : *Ce produit est uniquement être installé par du personnel qualifié.*

Pour se conformer aux normes FCC/IC réglementation limitée à la fois la puissance maximale de sortie RF et l'exposition humaine aux rayonnements RF, gain d'antenne maximal ne doit pas dépasser les valeurs indiquées dans les tableaux de la section de gain d'antenne maximal.

Avertissement : *Une distance minimale de 20 cm doit être maintenue entre l'antenne (s) utilisées pour cet émetteur et l'ensemble du personnel.*

Maximum Antenna Gain (Gain D'antenne Maximal)

The Wi-Fi X-Card may transmit simultaneously with other co-located radio transmitters within a host device, as permitted by FCC/IC multi-transmitter product procedures. The antenna gain must not exceed the limits and configurations shown in the following tables:

Device	Frequency Band	FCC ID/IC Number			
		N7NMC8705/ 2417C-MC8705		N7N-MC5728/ 2417C-MC5728	
		Standalone	Collocated	Standalone	Collocated
GX400	Cellular Band	7.5 dBi	6 dBi	4.55 dBi	3 dBi
	PCS Band	3 dBi	3 dBi	2.85 dBi	2.5 dBi
Collocated Transmitter (Wi-Fi X-Card Option)	WLAN (2.4 GHz)	N/A	2 dBi	N/A	2 dBi

Device	Frequency Band	FCC ID/IC Number			
		N7NMC7700/ 2417C-MC7700		N7NMC7750/ 2417C-MC7750	
		Standalone	Collocated	Standalone	Collocated
GX440	Cellular Band	7.5 dBi	5 dBi	7.5 dBi	5.5 dBi
	PCS Band	3 dBi	3 dBi	3 dBi	3 dBi
	LTE Band 4	5.5 dBi	5.5 dBi	N/A	
	LTE Band 13	N/A		10.17 dBi	6.4 dBi
	LTE Band 17	9 dBi	6 dBi	N/A	
Collocated Transmitter (Wi-Fi X-Card Option)	WLAN (2.4 GHz)	N/A	2 dBi	N/A	2 dBi

EU

Sierra Wireless hereby declares the AirLink GX series conforms to all the essential requirements of Directive 1999/5/EC.

Products are marked with a CE and notified body number and can be used throughout the European community. The alert symbol indicates that usage restrictions apply.



The AirLink GX400 is compliant with the RF exposure requirements at 20 cm separation distance specified in EN 62311:2008 and 1999/519/EC for mobile exposure conditions, provided the maximum antenna gain does not exceed the limits given in the table below.

Model	Frequency (MHz)	Maximum Antenna Gain (dBi)
GX400 (MC8705 module)	880–915	3.00
	1710–1785	9.00
	1920–1980	12.00
Optional Wi-Fi Card	2400–2483.5	2.00

Note: This Wi-Fi card only works in the 2.4 GHz band.

Warning: *This product is only to be installed by qualified personnel.*

Warning: *A minimum separation distance of 20 cm must be maintained between the antenna(s) used for this transmitter and all personnel.*

France

2.4 Ghz for Metropolitan France

In all metropolitan departments, wireless LAN frequencies can be used under the following conditions for either public or private use:

- **Indoor use:** Maximum power of (EIRP*) of 100 mW for the 2400-2454 GHz frequency band.
- **Outdoor use:** Maximum power of (EIRP*) of 100 mW for the 2400-2454 GHz frequency band and with maximum power of (EIRP*) of 100 mW for the 2454-2483 GHz frequency band.

Declaration of Conformity

The Declaration of Conformity made under Directive 1999/5/EC is available for viewing at the following location in the EU community.

Sierra Wireless (UK) Limited

Suite 5, The Hub Fowler Avenue

Farnborough Business Park

Farnborough, United Kingdom GU14 7JP

WEEE Notice



If you purchased your AirLink GX series in Europe, please return it to your dealer or supplier at the end of its life. WEEE products may be recognized by their wheeled bin label on the product label.

»» Index

A

- ACEmanager, configuring device with 31
- Activity LED 23
- Address, IP for device 21
- AirVantage, AVMS 14
- ALEOS
 - default user name and password 21
 - description of 12
 - X-Card installed 27
- Analog input voltage sensing
 - on power connector 26
 - on X-Card 28
- Antenna
 - auxiliary receive port 11
 - connection of 21
 - Diversity/AUX 11
 - GPS connector 11
 - maximum gain 11
 - receive and transmit port 11
 - safe mounting 17
 - separation 18
- AT commands 33
- AUX/Diversity antenna connector 11
- AVMS 14

B

- Battery
 - avoid draining when engine off 25
 - connection to 25

C

- Cables, power and data, connection of 21
- Cloud computing with AVMS 14
- Communication
 - ACEmanager, using 31
 - AirVantage 14
 - AT commands, using 33
 - command line prompt, using 22
 - connection 21
 - default password and user name 22
 - Ethernet connector 11
 - Ethernet X-Card 28
 - Ethernet, connection and test 21
 - no signal present 23
 - RS-232 port on X-Card 28
 - TCP PAD 11
 - UDP PAD 11
 - virtual Ethernet/serial port via USB 11
 - Wi-Fi X-Card 27
 - X-Card RS-232 port 28
- Computer, connecting to device 21

- Configuring with
 - ACEmanager 31
 - AirVantage 32
 - AT commands 33
- Connecting to
 - ALEOS homepage 21
 - devices and power 21
 - VCC, ignition and external devices 24

D

- Default
 - settings for device, reset to 11
 - user name and password 22
- Digital I/O pins on X-Card 28
- Diversity/AUX Antenna Connector 11

E

- Ethernet
 - computer connection and log in 21
 - connector 11
 - virtual Ethernet/serial port 31
- Expansion Card 12, 27

G

- GPS
 - antenna connector 11
 - connected to device, LED 23
- Ground connection 24

H

- Homepage, ALEOS, connecting to 21

I

- Ignition sense pin, on power connector 25
- Input/Output X-Card 28
- Installing SIM card 16, 27
- IP address
 - for device 21
 - obtaining with command line prompt 22

L

- Laptop, connecting to device 21
- LED
 - also see specific LED
 - cycling yellow 22
 - description of LED 22
 - Log in screen, ACEmanager 21

M

Measuring external voltages 26
Mounting
 general instructions 17
 vehicle 17

N

Network LED 23
No SIM or Unexpected SIM status message 27

O

On/Off, device turn on with qualified voltage 25
Output/Input X-Card 28

P

Password and user name, default 22
Pinging device with command line prompt 22
Power
 battery connection 25
 connected to device 23
 connector 11
 connector, measuring external voltages 26
 LED 23
 qualified voltage for device turn on/off 25
 stop draining battery when engine off 25

R

Receive port, backup 11
Receiving signal, LED 23
Reset button 11
Reset device 22
RS-232 port
 on rear panel 11
 on X-Card 28

S

Serial port
 on X-Card 28
 RS-232 11
 virtual serial port 31
Signal LED 23

SIM card
 card not installed message 27
 installing 16, 27
Starting device 21

T

TCP PAD 11
Turn on device 21

U

UDP PAD 11
Unexpected SIM status or No SIM message 27
USB port
 on front panel 11
 uses of, installing drivers for 31
User name and password, default 22

V

VCC connector 24
Vehicle
 antenna, safe mounting 17
 battery connection 25
 connection of Pin 3 for device turn on/off 25
Virtual Ethernet port 11
Voltage
 analog voltage sensing pins on X-Card 28
 monitoring battery or power input 26
 starting device with qualified voltage 25

W

Wi-Fi X-Card 27

X

X-Card 12, 27
 analog voltage input pins 29
 digital I/O, analog voltage sensing, pins 28
 I/O 28
 installed indicator in ALEOS 27
 Wi-Fi 27

Y

Yellow LED, cycling 22

