

DEESEA
POWER & LIGHT



Sealite® Sphere

3100, 5100, 5500, 6100



Operator's Manual

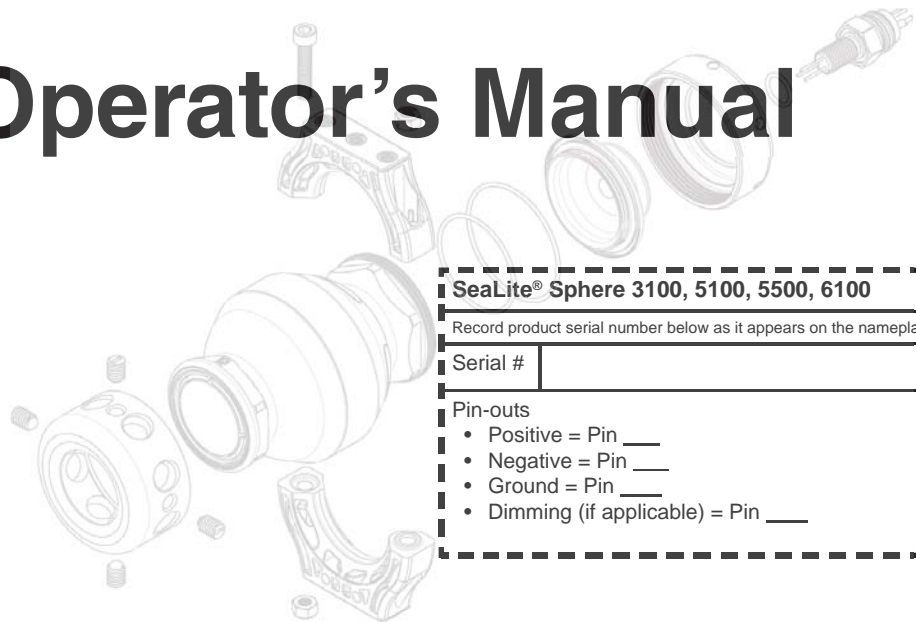

SeaLite® Sphere 3100, 5100, 5500, 6100

Record product serial number below as it appears on the nameplate.

Serial #

Pin-outs

- Positive = Pin ____
- Negative = Pin ____
- Ground = Pin ____
- Dimming (if applicable) = Pin ____

T: (858) 576-1261
F: (858) 576-0219

4033 Ruffin Road
San Diego, CA
92123- 1817 USA

www.deepsea.com
sales@deepsea.com



Specification Overview

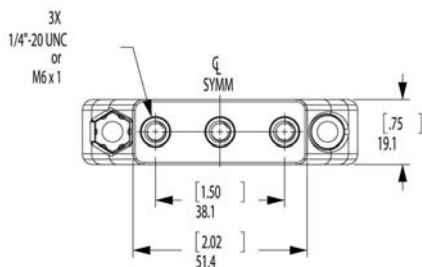
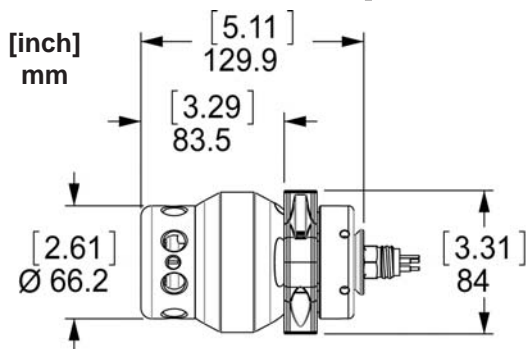

MCBH3MP
(High Voltage AC/DC)

- 1 = Hot (DC +)
- 2 = Neutral (DC -)
- 3 = Chassis

MCBH5MP
(Low Voltage DC)

- 1 = Positive
- 2 = Negative
- 3 = Chassis
- 4 = Not Used
- 5 = 0-5 V DC Control (0-5V DC Control ground to Pin 2)

**Other connector options are available upon request.*

	SLS-3100	SLS-5100	SLS-6100	SLS-5500
Electrical Specifications				
Input*	10-36V DC 1.7A @ 24V DC 41 W	20-36V DC 3.3A @ 24V DC 80W	110-140VAC 120-150VDC 1.6A @ 120VAC typical 1.1A @ 135VDC typical	215 - 275V AC 275 - 375V DC 0.62A @ 220V AC Nominal (275V AC Max), 130W Max 0.32A @ 280V DC Nominal (375V DC Max), 130W Max
Dimming	0-5V Control Loop (Standard) Variable Voltage (Optional)		AC Phase Control Dimmer & Variable Voltage (Variac)	
Optical Specifications				
Lumens in Water (Flood Lights)	3700 Lumens typical	6200 Lumens typical	7500 Lumens typical	5000 Lumens typical
True Lumens/Watt	90 lm/w	77 lm/w	50 lm/w	35 lm/w
True Lumens/Weight in Water	16 lm/g	27 lm/g	24 lm/g	16 lm/g
Color	White 6K mix; other color options available			
Color Temp	Standard: 6000K (White 6K) Optional: 9000K (White LED's)			
Beam Pattern in Water (FWHP)	Flood: 75°/Medium: 38°			
Color Rendering Index (CRI)	77 (Standard White LED's)			
Mechanical Specifications				
Body Material	Hard Anodized 6013-T8 Aluminum (Standard) Beryllium Copper (Optional)			
Window Material	Sapphire			
Mounts	High Strength Plastic Mounting Collar with Titanium inserts (1/4"-20 Imperial or 6mm Metric)			
Weight in Air	675 g (1.49 lbs) for standard Al housing		796g (1.75 lbs.) for standard Al housing	
Weight in Water	227g (0.50 lbs) for standard Al housing		314g (0.69 lbs.) for standard Al housing	
Impodable Volume	TBD	TBD	TBD	TBD
Environmental Specifications				
Depth Rating	6,000m - 20,000ft (8,820 psi)			
Pressure Rating	10,000 psi			
Crush Depth	13,000 psi (8,964 msw - 29,578 fsw)			
Operation Temp	-10°C - 40°C (14°F - 104° F)			

*DeepSea Power and Light offers a Universal SeaLite Sphere option with an input range of 90-250 VAC (50/60Hz) and 80-350 VDC. Please contact DeepSea for additional details.

Table of Contents

Specification Overview.....	2
Table of Contents	3
Safety Symbols	4
General Notes & Warning	4
Pre & Post Dive Inspection	4-5
Troubleshooting	5
Flooded Light Repair	5
RMA Procedure for Repair	5-6
Warranty.....	6
Appendix A Dimming Response Curves.....	7-10
Appendix B Low-Voltage DC Step Response Curve	11-12
Appendix C Beam Patterns	13-14
Appendix D Connector Replacement	15-17

Safety Symbols

In this operator's manual and on the product, safety symbols are used to communicate important safety information. This section is provided to improve understanding of these symbols.



This is the safety alert symbol. It is used to alert you to potential personal injury hazards. Obey all safety messages that follow this symbol to avoid possible injury or death.



DANGER indicates a hazardous situation which, if not avoided, could result in death or serious injury.



WARNING indicates a hazardous situation which, if not avoided, could result in damage to the product or bodily harm.



CAUTION indicates a hazardous situation which, if not avoided, could result in minor or moderate injury.



NOTICE indicates information that relates to the protection of property.



This symbol means read the operator's manual carefully before using the equipment. The operator's manual contains important information on the safe and proper operation of the equipment.



This symbol means always wear safety glasses with side shields or goggles when handling or using this equipment to reduce the risk of eye injury.



This symbol indicates the risk of electrical shock.

General Notes & Warnings

Your SeaLite® Sphere light is designed and built for years of maintenance-free operation.

Simple pre- and post-dive maintenance is all that should be done.

There should be no reason to ever open the housing of your SeaLite Sphere light. Your light was thoroughly pressure tested prior to leaving the factory to confirm the integrity of the complete assembly. Your light was designed with the ability to change the connector in the field in the rare case of delamination or breaking of the connector body leading to leaking.

You may run your SeaLite Sphere light at full power in air. This light is equipped with thermal sensing circuitry which will automatically fold back the light output and prevent it from overheating. The light will return to full brightness once it is submerged and allowed to cool.

WARNING

Tampering with the lighthouse in any way may damage the light and void your warranty.

Do not clean any part of the lighthouse with any type of alcohol.

Reconfiguring the pin-out of the light is potentially dangerous to the operator and can cause significant damage to the light. Any change to the pin-out should

be done only through consultation with the factory in order to provide proper documentation and new pin-out labeling. Failure to do so will result in the loss of warranty coverage for your light.

DANGER

When the SeaLite Sphere light is operated in air the body may reach temperatures in excess of 65° C (150°F). These temperatures may be enough to cause burns if the light is handled without protective clothing.

Do not operate any high voltage electrical equipment in or around water without using a Ground Fault Circuit Interrupter (GFCI) and an isolation transformer, especially when divers are in the water.

Pre & Post Dive Inspection

Check to make sure that the rear bulkhead connector is secure before deployment.

Check the following areas for previous damage, wear or corrosion: rear bulkhead connector, power cable, front window, and end-cap retainer.

Rinse your SeaLite Sphere light in fresh water after use in saltwater.

After each deployment, carefully check to make sure the light is operational and has not flooded. If it gets flooded, upon surfacing, the light can become internally

pressurized, which may be potentially dangerous. Additionally, if the power remains on when the light has partially flooded, it is possible for electrolytic generation of an explosive mixture of hydrogen and oxygen gases. If a light appears flooded upon removal from the water, it should be treated as potentially dangerous. Point the light away from persons and valuable equipment and make sure that the power is disconnected. See the Flooded Light Repair procedure for more information.

DC Strobing Capability

The LVDC driver used in the SLS-5100 and SLS-3100 have some limited, user defined, strobe and flash capability using the 0-5V analog dimming input. The output of the light can be made to turn on and off rapidly by applying a square-wave pulse with a 5V amplitude to the DIM pin of the light.

The response of the light has a 20ms time constant, about 70% of full brightness is achieved 20ms after the pulse is applied. The light then reaches >90% output after about 40ms. The same time constant applies to the turn-off behavior, but shuts off and enters stand-by mode after about 35ms.

The image in Appendix B shows the step response of the SLS-5100 driver. There is an additional turn-on delay of about 5ms that must be accounted for in any timing calculations.

Troubleshooting

If the light stops working while underwater assume that it has been flooded. See Flooded Light Repair procedure below.

Once it has been determined that the light is not flooded, or if it does not turn on during pre-deployment checks, check the input power cable/inline connector to make sure that correct voltage is being supplied, and that the correct pin-out is being used. See page 2 of this manual for electrical specs and connector pin assignments.

If the light still does not work, return it to DSPL using the RMA Procedure for Repair below.

CAUTION

Not every light will be wired to the DeepSea Power and Light pin-out. Please verify your pin-out before applying power to any light.

Flooded Light Repair

WARNING

If the light stops working while underwater, you should assume that it has been flooded. When working on a potentially flooded light, it is important to use appropriate personal protective equipment to include, at a minimum, eye and hand protection.

1. Place the light face down on a table making sure that the connector side is facing up.
2. Unscrew the End-Cap Retainer with a spanner wrench.
3. Slowly depressurize the connector compartment and remove the end-cap with the connector attached to it.
4. Without removing the circuit board, rinse the compartment with clean fresh water.
5. Bake the light in a warm oven at no more than 100° C or 212° F for at least 30 minutes to bake out any moisture that may be present.
6. If it is determined that the flooding occurred due to damage to the connector, please see the Changing the Connector section below.
7. Once it is determined that the light is not or no longer internally pressurized, and the flooding was not due to the connector; it is recommended that the light be returned with the End-Cap Retainer partly unscrewed as in step 2 above, to DeepSea Power & Light for evaluation and repair using the RMA Procedure for Repair below.

DeepSea Power & Light cannot be responsible for any damage incurred during emergency field repairs. Evidence of opened housings will void the warranty. Such repairs should be undertaken only as a last resort and by qualified personnel.

Changing the Connector

Please see Appendix C for details on changing the connector in the case of flooding.

RMA Procedure for Repair

Should it be necessary to return your SeaLite Sphere light to the factory, follow the procedure for the Flooded Light Repair above, leaving the connector partially unscrewed.

For warranty and non-warranty repairs please contact DeepSea Power & Light for a RMA number prior to returning your item. Please have your light model number, serial number and any other pertinent information along with a description of the problem, on hand when you call, or include them in a fax or e-mail.

When shipping your item, be sure that the freight is pre-paid (CODs will not be accepted) and that the RMA number is clearly printed on the outside of the box.

All shipments should be sent to the address below:

DeepSea Power & Light
Attn: RMA #####
4033 Ruffin Road
San Diego, CA 92123-1817
U.S.A
Tel: (858) 576-1261
Fax: 858-576-0219
e-mail: RMA@deepsea.com

Limited Warranty

Seller warrants that the goods (except internal electronic components) sold under this contract will be free from defect in material and workmanship for a period of one year from the date of shipment from the factory, if they have been properly used. Internal electronic components are warranted for 90 days from the date of shipment from the factory, if they have been properly used. This warranty will be limited to the repair or replacement of parts and the necessary labor and services required to repair the goods. IT IS EXPRESSLY AGREED THAT THIS WARRANTY WILL BE IN LIEU OF ALL WARRANTIES OF FITNESS AND IN LIEU OF THE WARRANTY OF MERCHANTABILITY. This warranty is the exclusive and only warranty to pass with the goods under this contract. No agent, employee, or representative of the Seller has any authority to bind Seller to any information, representation, or warranty concerning the goods sold under this contract, and unless an affirmation, representation, or warranty made by an agent, employee, or representative is specifically included within this contract, it will not be enforceable by Buyer. If notice of defect is given to DeepSea Power & Light, Inc. within such 90 day or one year warranty period, the sole obligation of DeepSea Power & Light, Inc. shall be to furnish new or repaired parts free of charge in exchange for parts which have been proved defective and does not include any other costs such as the cost of removal of the defective part, installation, labor, or consequential damages of any kind, the exclusive remedy being to require DeepSea Power & Light, Inc. to furnish such new parts. Under no circumstances shall the Buyer be entitled to recover any incidental damages as that term is defined in Commercial Code §2715.



www.deepsea.com
sales@deepsea.com

4033 Ruffin Road
San Diego, CA
92123-1817 USA

T: (800) 487-3775
F: (858) 576-0219



Appendix A

Dimming Response Curves

SeaLite Sphere Phase Dimming Responses

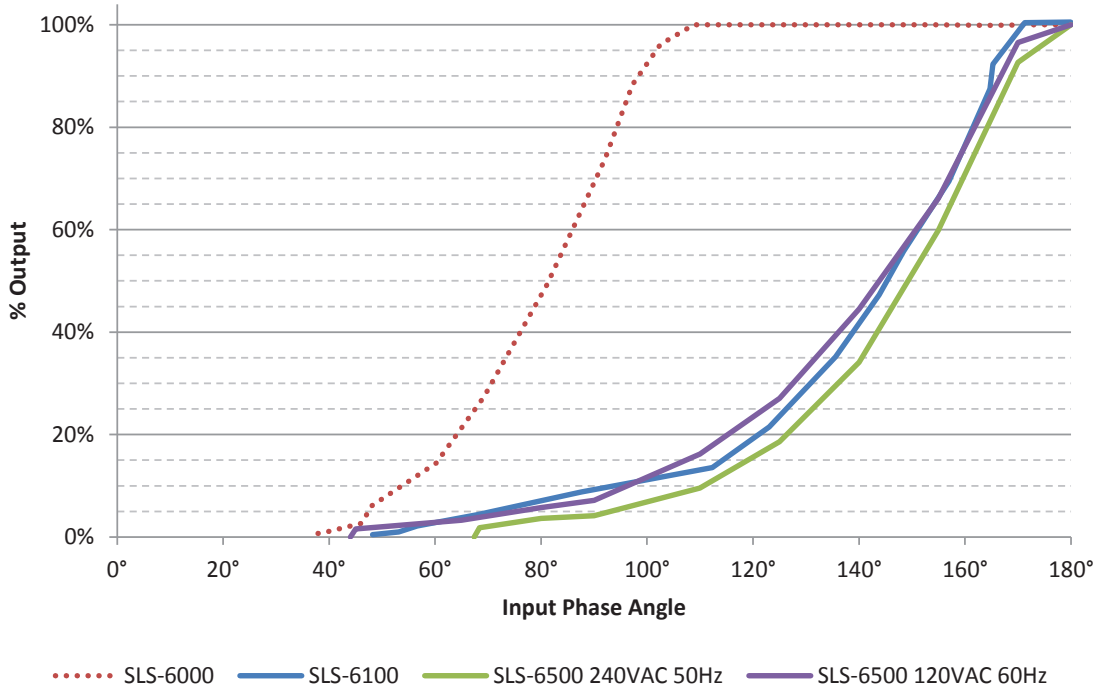

SLS-6100 Variable Voltage Dimming Response

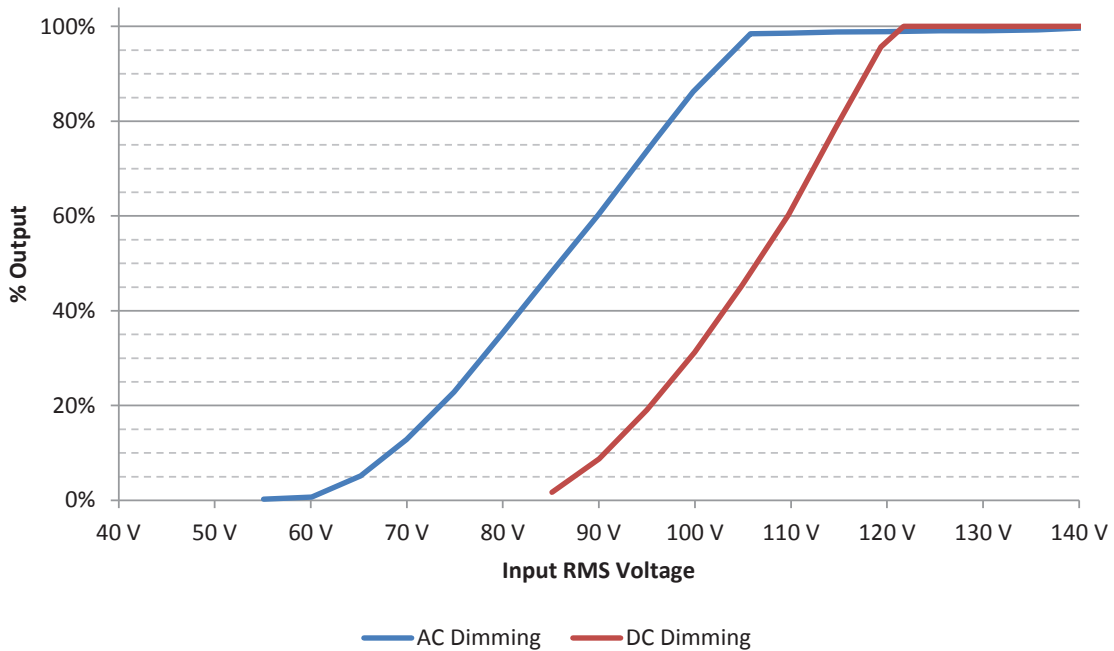

SLS-5500 Phase Dimming Response

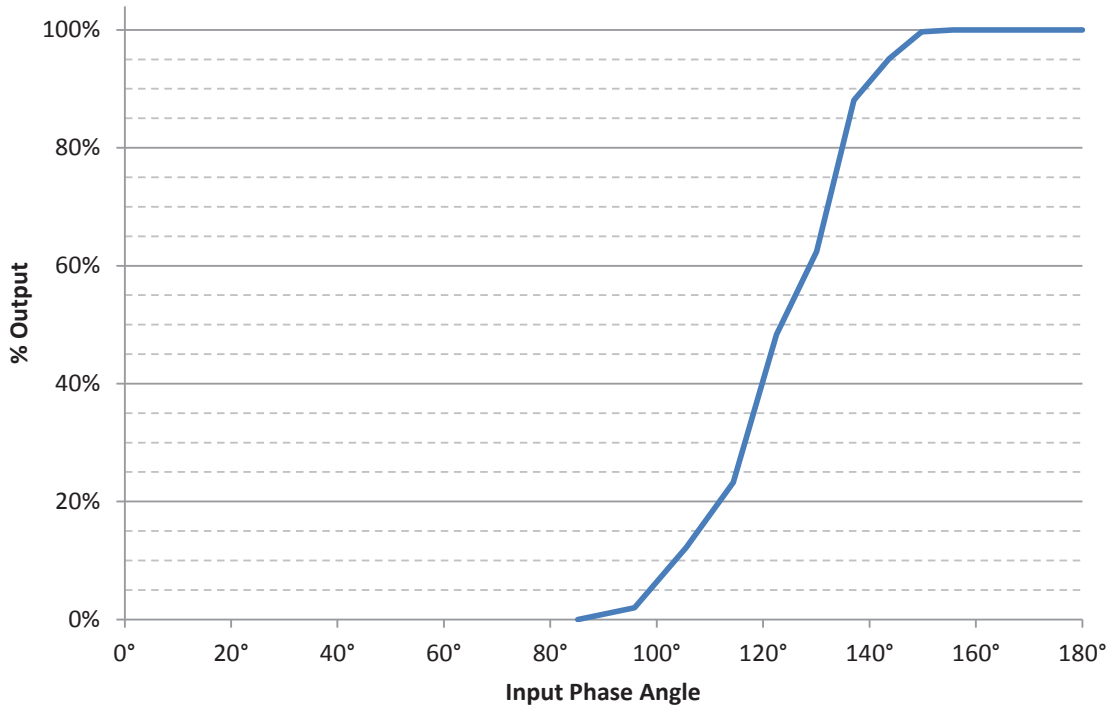

SLS-5500 Variable Voltage Dimming Response

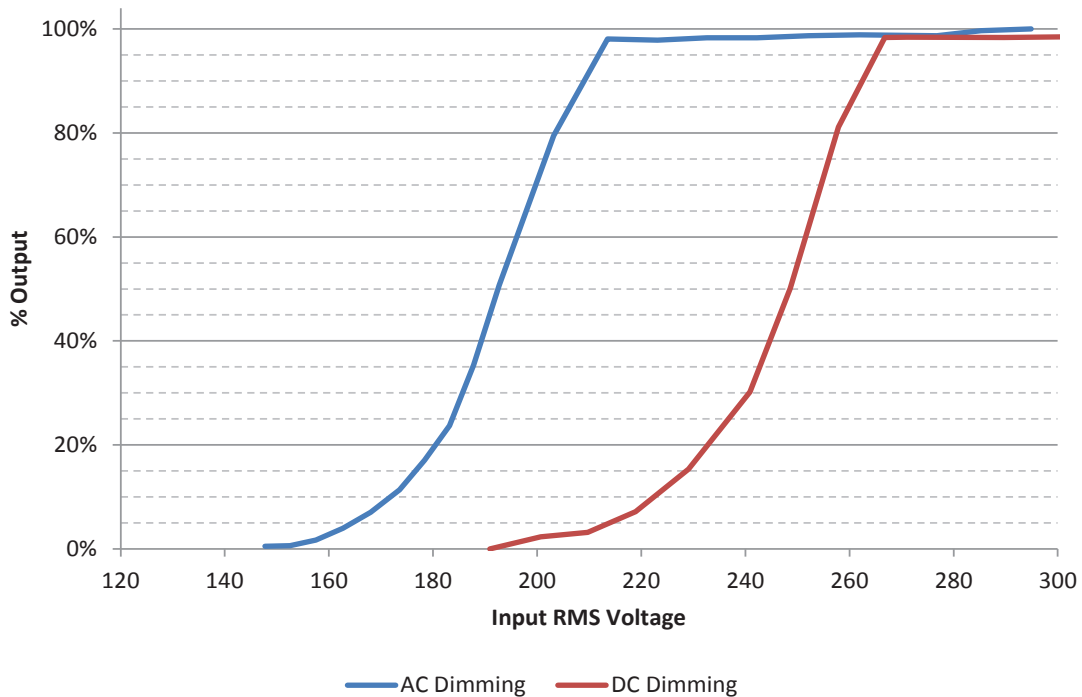

SLS-3100 & SLS-5100 0-5V Dimming Response

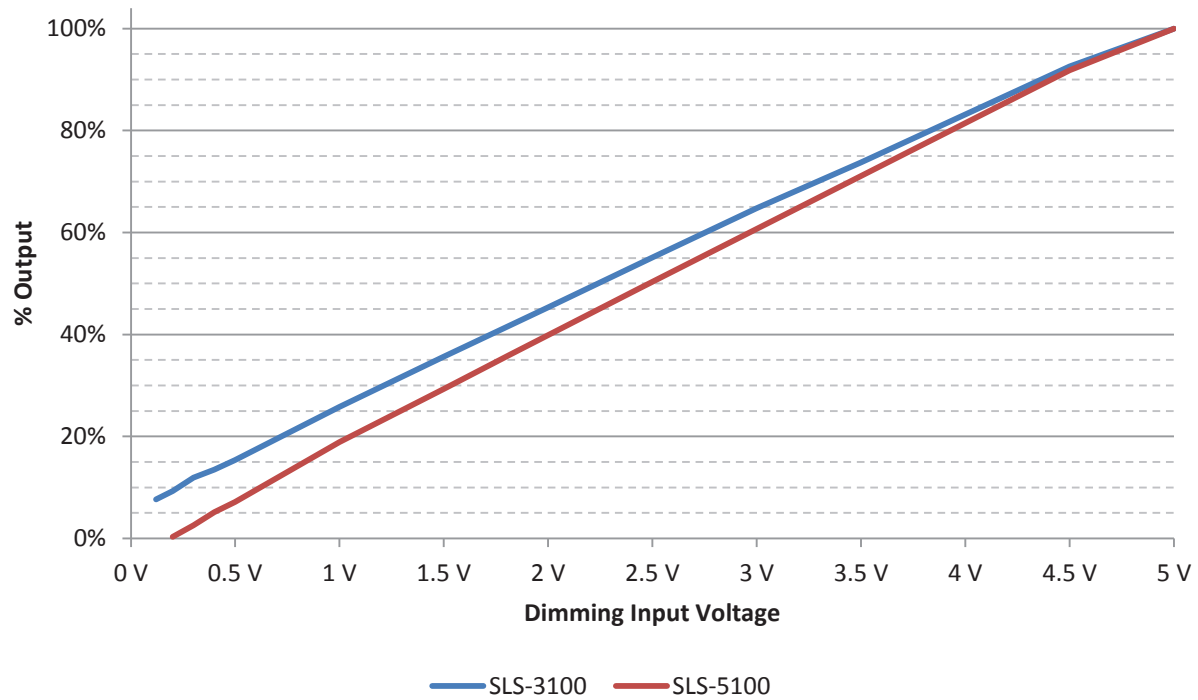

Appendix B

Low-Voltage DC Step Response Curve

SLS 3100/5100 Dimming Input Response Characteristics

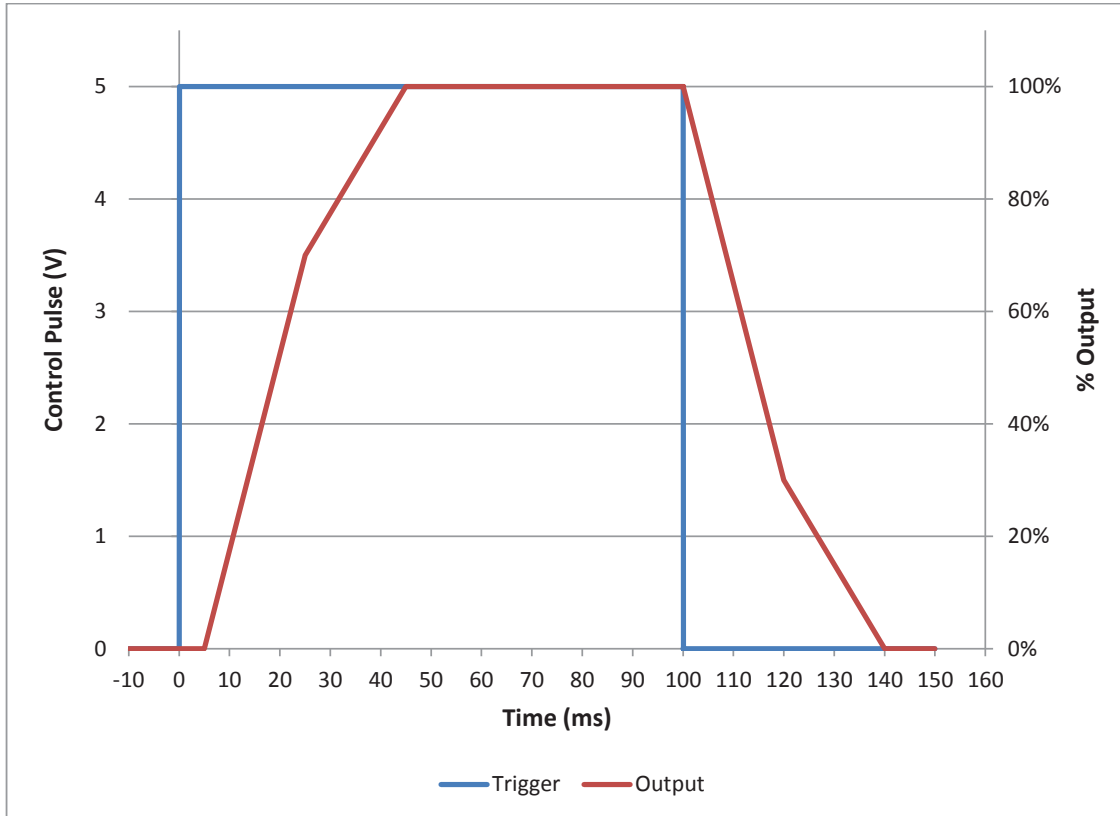

Actual Pulse Waveform Capture

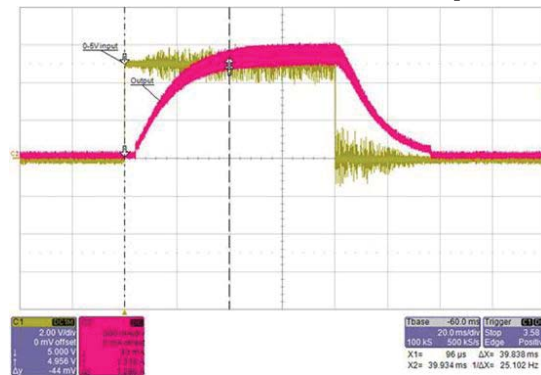

Appendix C

Beam Patterns

Sphere Sealite in Water R&D 001

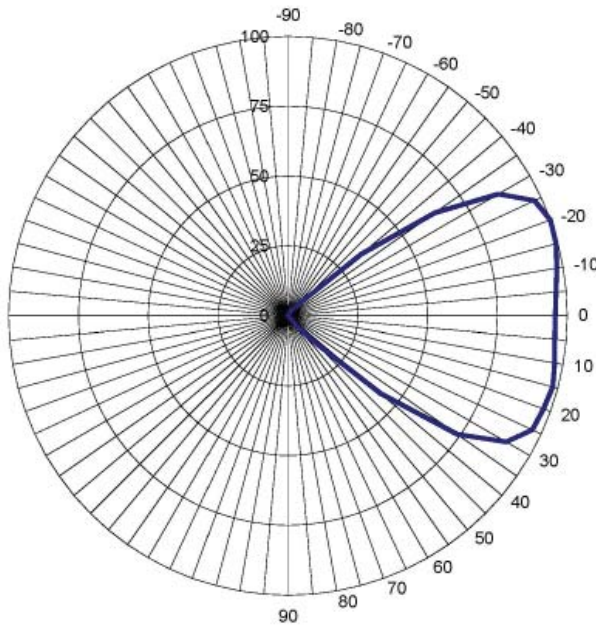

Beam Angle FWHM	75 Degrees
Lux @ 1M	NA
Lumens	NA
CCT	NA
Radiated Power	NA

The scales are:
 X = angle (0 is the light pointing straight at the detector)
 Y = relative output compared to the brightest point. 0-100%

2011-10-19

SeaLite Sphere Beam Pattern SLS Medium Spot - In Water

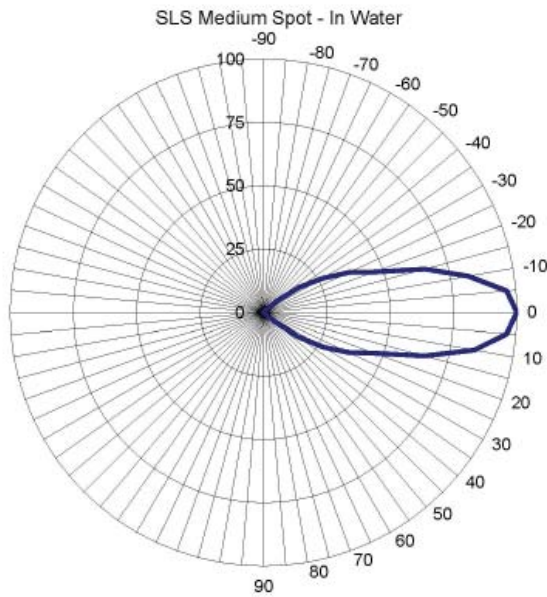

Beam Angle FWHM	38 Degrees
Lumens	5115
CCT	6147
Radiated Power	16.79

The scales are:
 X = angle (0 is the light pointing straight at the detector)
 Y = relative output compared to the brightest point. 0-100%

8/22/2013

Appendix D

Connector Replacement

Connector Replacement Instructions

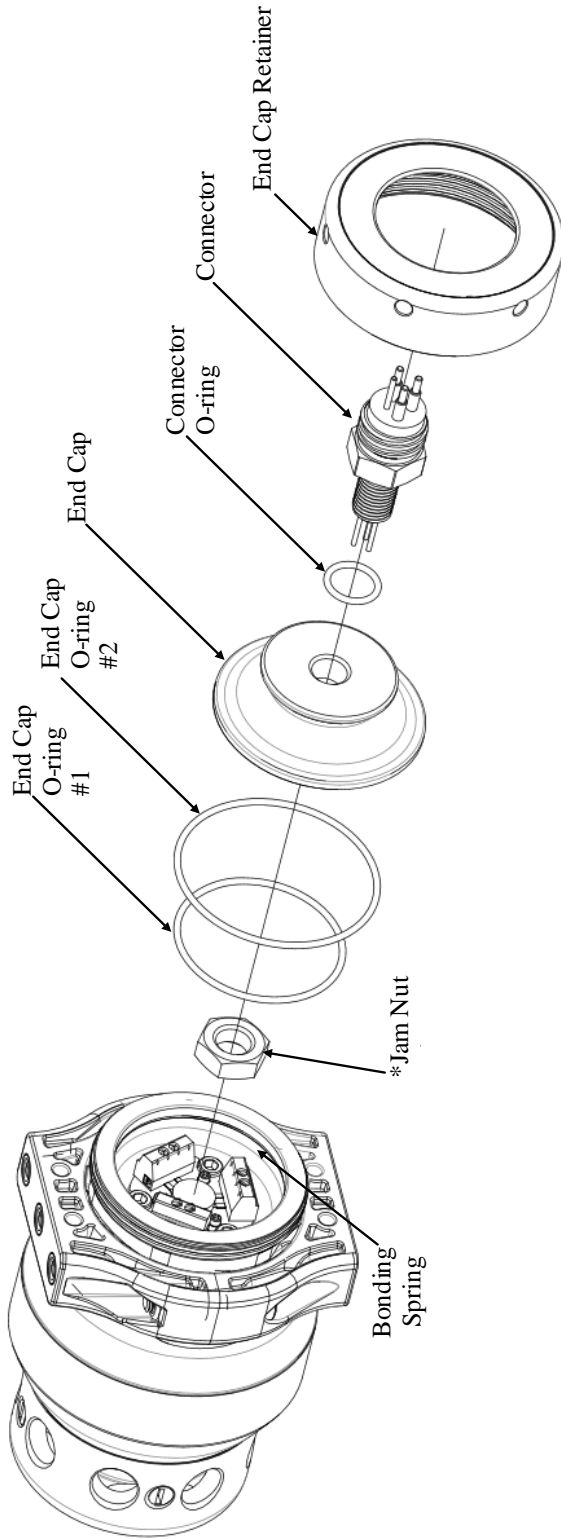

Connector Replacement Instructions

1. Unscrew the End Cap Retainer.
 - a. Recommended Spanner Wrench: Armstrong 1¼-3" Model 34-358.
2. Pull out the End Cap with the Connector.
3. Disconnect the Connector Wires from the Terminal Blocks.
4. Replace the Connector and the Connector O-ring. (Grease O-ring)
5. Install the Jam Nut. (*If applicable)
6. Inspect both End Cap O-rings.
7. Replace both End Cap O-rings if necessary. (Grease O-rings)
8. Re-connect the wires to the Terminal Blocks. (See Chart)
9. Verify that the Bonding Spring is still installed.
10. Re-install the End Cap
11. Re-install the End Cap retainer.

Connector Wire Reference		
Position	DC Lights	AC Lights
L	DC +	Line
N	DC -	Neutral
CH	Chassis	Chassis
R	Reference (0-5 VDC)	Not Connected
A	Auxiliary A	Auxiliary A
B	Auxiliary B	Auxiliary B

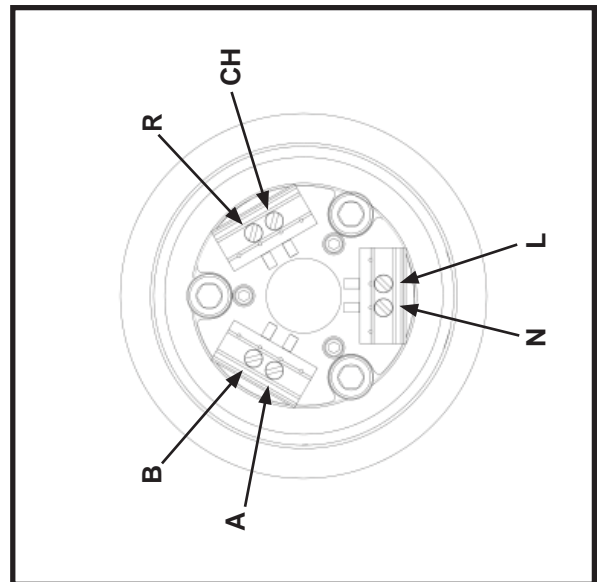

*Lightly grease with DC-111 or equivalent.
 *Large thread size connectors may use custom Jam Nuts, contact DSPL for details.

Spare Parts for Connector Replacement	
Description	P/N
End-Cap O-Ring Kit	712-045-601-0A-01
2-017 size O-Ring (XSG3BCL Connector)	2-017 v0884-75
2-116 size O-Ring (5507-1503 Connector)	2-116 v0884-75
2-014 size O-Ring (BH3MP, MCBH3MP, LPBH3MP Connector)	2-014 v0884-75
BH3MP Connector Assembly	140-00012-02
MCBH3MP Connector Assembly	140-00372-02
XSG3BCL Connector Assembly	140-00137
LPBH3MP Connector Assembly	140-00073-01
5507-1503 Connector Assembly	140-00275
End Cap 7/16"-20 (BH3MP, MCBH3MP, LPBH3MP Connector)	712-045-009-0A-01
End Cap 1/2"-20 (XSG3BCL Connector)	712-045-009-0A-02
End Cap 5/8"-18 (5507-1503 Connector)	712-045-009-0A-04
Jam Nut 7/16"-20 (BH3MP, MCBH3MP, LP-BH3MP Connector)	420-00024
Jam Nut 1/2"-20 (XSG3BCL Connector)	420-00049
Jam Nut 5/8"-18 (5507-1503 Connector)	420-00051

Note: DeepSea Power & Light strongly recommends Viton as the preferred O-ring material for connector replacements. If Viton is not available, Buna is an acceptable substitute.