

**CUPLOK SCAFFOLD
SYSTEM
USER GUIDE**

SGB



September 2005

Introduction

The Cuplok Scaffold System is a fully galvanised multi purpose steel scaffold for general access and supporting vertical loads.

Cuplok independent tied access scaffolds built up to 2.5m bays have a loading capability of 3kN (300kg) per square metre. For other applications, such as birdcage, mobile towers and staircases the loadings may vary, and advice should be sought from your local SGB Branch.

Cuplok 3000 is covered in a separate Safety Guide. Please contact your local branch.

If you need further information, design advice or any other help with this product please contact your local branch on 08705 288388.

Compliances

All Access Scaffolds must comply with the general requirements of the following:

- Construction (Health, Safety & Welfare) Regulations 1996
- Code of Practice BS5973

However, Cuplok, as a proprietary system, is not based upon scaffold tube and fittings, and certain requirements in BS5973 may not be relevant. In these cases, if there is conflict, SGB data should be used. If you have any queries, please contact your local branch.

Safety

Safety Harnesses

All scaffold erectors must wear a harness whilst erecting, dismantling and working on scaffolding over 4 metres platform height. All methods of erection/dismantling scaffolding and the use of a Safety harness should be in conjunction with SG4:00 Guidance Notes issued by the NASC.

Specific guidelines in relation to the use of Safety Harnesses in conjunction with the SGB Cuplok Scaffolding System are available. SGB can supply you with a suitable harness. Please contact your local branch.

Platform Loadings - working lifts

2m lift access scaffolds:	1.5kN/m ²
1.5m bricklayers scaffold	
for 1 platform:	3.0kN/m ²
or 2 platforms:	1 at 3.0kN/m ² , 1 at 1.5kN/m ²

Preparation and Inspection

Before commencing the erection of any Cuplok Scaffold, great care should be taken to see that the ground is suitable. On soft or made-up ground the scaffold should be erected on timber sole plates of appropriate size. Bricks or blocks should not be used.

The scaffold should be started on the highest part of the ground – this will make levelling easier as the scaffolding progresses horizontally.

Always check whether or not an inside board platform of one, two or three boards will be required. If so this will determine the distance of the scaffold from the building.

Inspect the equipment before use, to ensure that it is not damaged or fails to function properly.

Ensure you are using the correct PPE equipment for the application you are working on.

Components

Main components

Standards

Cuplok Standards are made from a high grade steel tube and are identified by a red flash at the bottom. Top cups have 4 lugs. Earlier stocks were made from a different grade steel and carry slightly less load when used in applications such as falsework to bridges. For these two scaffold types please refer to the Cuplok Falsework Brochure and User Guide or the Cuplok User Manual. For all normal access scaffold either type is suitable.

Ledgers/Transoms

Cuplok tubular ledgers are also used for transoms or guardrails and are fully interchangeable. Cuplok tubular ledgers are used with standard boards. Omega transoms are used with timber or steel battens. Cuplok 3000 Transoms (see separate Guide) are able to accept Steel or Alu-Ply Decks.

Intermediate Transoms

Used to provide intermediate support to scaffold boards. Also used at board ends. They are fitted with a wedge operated lock to prevent accidental sliding in use.

Base Jacks

Cuplok Universal jacks must always be used in conjunction with Head/Baseplates, sitting on scaffold board or other suitable sole plates as in normal scaffolding practice. The jack must always be fitted so that the unthreaded portion is inside the standard to prevent the minimum overlap in the tube being reduced.

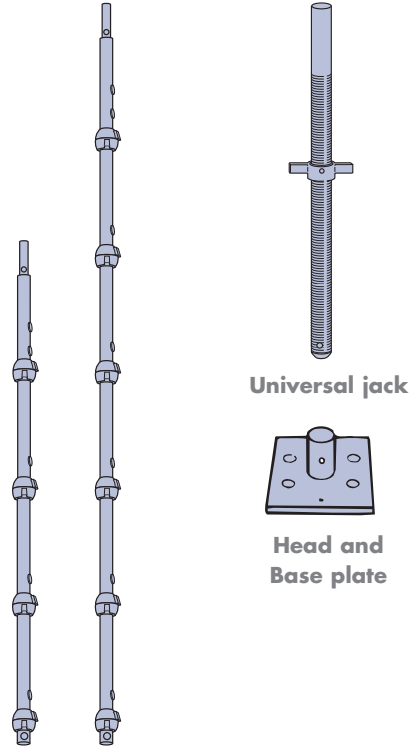

2m and 3m Standards

Universal jack

Head and Base plate



2.5m, 1.8m and 1.3m Ledger

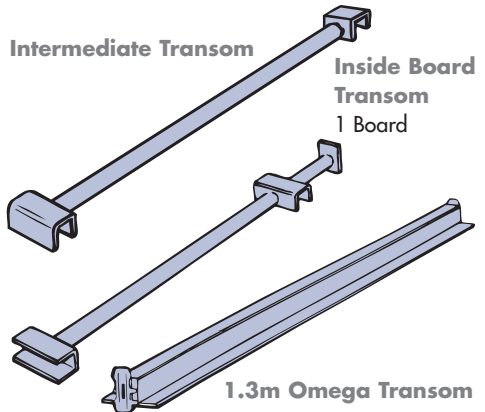

Intermediate Transom

Inside Board Transom
1 Board

1.3m Omega Transom

Scaffold Boards

All standard scaffold boards are suitable for use with Cuplok when laid over tubular transoms. They safely span distances between 1.2m and 1.5m for most types, but care must be taken to check the embossed bands at the end to determine the max permissible span. Intermediate transoms must be used to limit the span and also to give support to the ends.

Battens (used with Omega Transoms)

Cuplok Battens, both steel and timber, are suitable for spans up to 2.5m without intermediate support for loadings of up to 3kN/m².

Toe boards

Can be provided by scaffold boards, timber or steel battens using the appropriate clips from the Cuplok range.

Guardrails

The standard heights for guard rails (approx 0.5m and 1.0m) are predetermined by the Cuplok System. Brick guard panels may be used with Cuplok, however, double guard rails and toe boards must always be provided.

Spigot Pins

Only required where resistance to uplift is required and would be required when scaffold projects above last tie, or when using hop-up brackets, or with crane handled assemblies.

Spigot pins should be used to lock the standards against uplift at all joints down to the last tied lift below the hop-ups. On a scaffold where the brackets will be moved, spigot pins should be used throughout at time of erection to minimise risk of omission during modifying of platform levels.

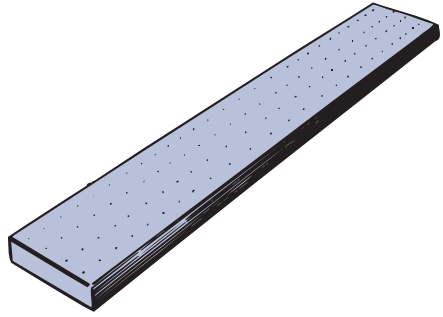

Steel Batten

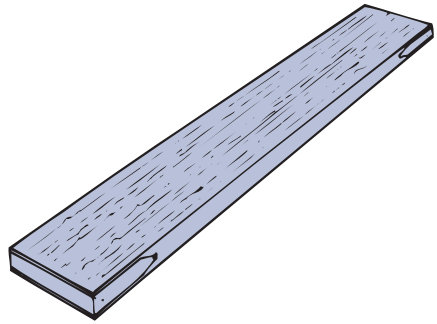

Timber Batten



Toe Board Clip
Steel Batten

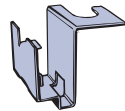

Toe Board Clip
Timber Batten

Foot ties

Foot ties (i.e. a level of ledgers and transoms in the bottom cup) should be fitted to all scaffolds with hop-up brackets.

It is generally advisable to install foot ties whenever practicable.

Inside Boards and Hop-up Brackets

Cuplok can incorporate 1, 2 or 3 inside boards. Due to the wide variation of applications involving the construction of corners, reference should be made to the Cuplok Users Manual for specific guidance.

Hop-up Brackets

The maximum permitted loading on hop-up brackets is as follows:

1 board:	3kN/m ²
2 board:	1.5 kN/m ²
3 board:	0.75kN/m ²

Diagonal Bracing

Face Bracing

- One bay of bracing to the full height is required every 8 bays (20m).
- On short runs up to 4 bays (10m), one braced bay should be provided.
- Over 10m at least two bays of bracing are required.

As only one blade can be located at each node point, parallel bracing is used. Braces must go from platform level to platform level. Note that the bottom brace is always fitted in a 1.0 or 1.5m lift and should be of the appropriate size.

Ledger Bracing and Plan Bracing

The Cuplok node connection is extremely rigid and ledger bracing is not normally required. On very high scaffolds it may be specified to increase the load capacity but all such work should be referred to an SGB design office via your local branch. Plan bracing is also uncommon and should be the subject of consideration by the design office. See also notes under 'Typical Tie Patterns'.

When the hop-up level occurs between tied levels,

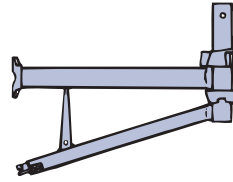

Hop Up Bracket
2 and 3 Board

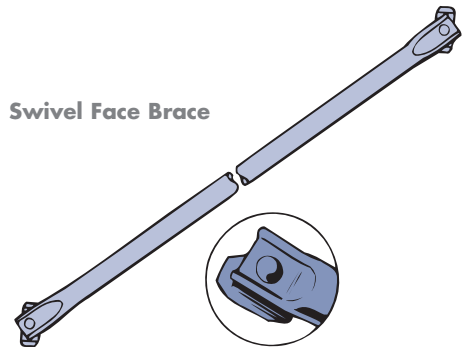

Swivel Face Brace

ledger bracing must be used at each lift down to the next tie.

Corners and Returns

Rigid corners are formed in Cuplok by using a 1.3m square corner bay. When this is not possible the scaffold can be erected using the 'flypast' method. For scaffolds with scaffold boards, check the Cuplok return devices (or tube and fittings) are used to connect the two runs at each level. For scaffolds fitted with battens an Omega Return Transom is used. In both cases attention must be given to providing proper toe boards and this may involve cutting boards to suit the various dimensions of the corners. Further information is contained in the Cuplok Users Manual.

Using Standard Scaffold Boards

- 1 Layout out the ledger and transoms for the first bay in their approximate positions. Then insert an adjustable base jack into each of the first pair of standards.

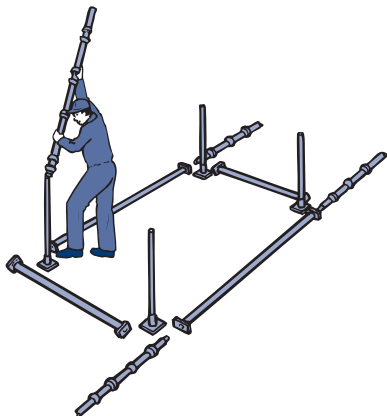

- 2 Connect the standards with a transom in the lowest cup joint by inserting the blades into the cups. Level the transom. Always start the scaffold with a three metre standard on the outside and a two metre standard on the inside, so joints are staggered.

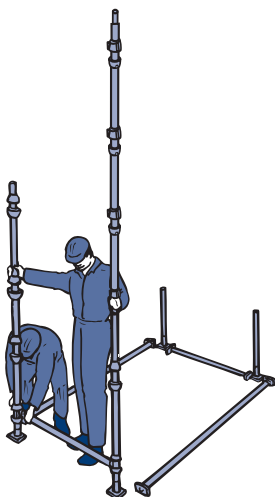

- 3 With one person still holding the first pair of standards, the second person inserts a jack into the third standard and connects it to the first pair with a ledger. The upper cup can then be dropped temporarily into the locking position. The structure is now self supporting and the fourth standard can now be connected by a further ledger and transom and the bay levelled. Once the base lift has been completely levelled, your spirit level will no longer be required.

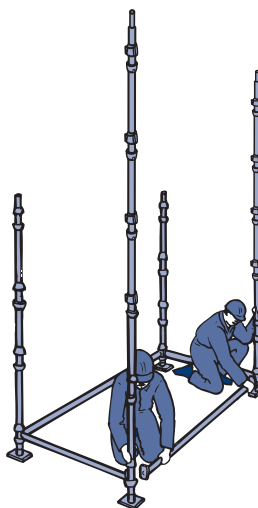

Using the Omega Batten System

The same erection procedure is adopted for the Omega Batten System as for the Scaffold Board System, except that the Omega top hat type transom is used in place of the tubular transom. No intermediate board supports will be required.

- 4 The first bay of Cuplok is completed by locating the upper ledgers and transoms. It is now a simple matter to extend the scaffold structure by connecting ledgers, transoms and standards to the existing bay. The top fixing cups can now be secured with a hammer. The scaffold should

now be secured by the ties/anchors or equivalent methods at the earliest opportunity (see the SGB Ties and Anchor Usres Guide).

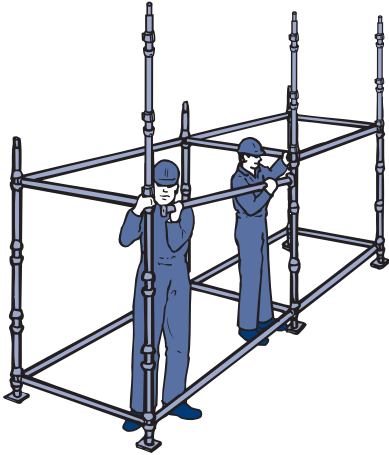

- 5** The working platform can now be constructed. To ensure safe erection, alteration and dismantling of the scaffolding it is important that the procedures outlined in the Guidance Note SG4:00* is followed. In summary, a minimum of three boards should be placed from below for erectors and single guard rails should be installed as work progresses along each lift (double guard rails and toe boards will be required to complete). Scaffolders should safely clip on to ledgers or guard rails at 4 metres height or above. Full body harnesses should be worn and lanyards attached (see SGB User Guide – The Use of Safety Harness with SGB Cuplok Scaffold System)

****This Guidance Note is published by the NASC and is available from them or from SGB Branches.***

- 6** Intermediate transoms are secured at strategic points (1.2m and 1.5m support frequency) across the ledgers to support 38mm scaffold

boards. The scaffold boards and toeboards can now be positioned. Two standard ledgers can be located 0.5 and 1.0 metres above the working platform to form the double guardrails.

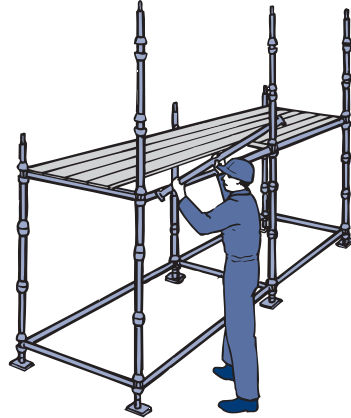

- 7** Additional lifts can now be constructed simply by adding further standards on to the spigots of the lower lift, and connecting them with ledgers and transoms, following the steps in paragraph **5**. When swivel face braces are used, these are located at the cup joints and should span from lift level to lift level (see face bracing).

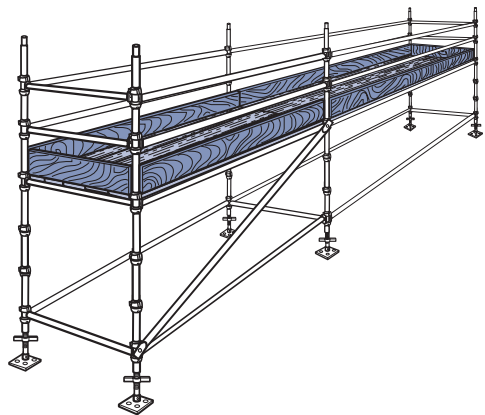

Maximum heights and tying-in patterns

Working lift		1	1	1	2	1	2	
Lifts boarded		-	1	2	-	7	2	
MAXIMUM NUMBER OF LIFTS ALLOWED	2m lift	Foot tied	15	15	15	10	-	4
		Not foot tied	15	13	10	5	-	-
	8m tie pattern	Foot tied	14	11	8	-	-	-
		Not foot tied	10	7	4	-	-	-
	1.5m lift	Foot tied	20	20	20	20	20	20
	4.5m tie pattern	Not foot tied	20	20	20	20	20	18
	1.5m lift	Foot tied	20	20	20	19	16	13
	6m tie pattern	Not foot tied	20	20	20	14	11	8

Notes:

Other combinations and greater heights are possible. Consult your local branch.

- Not to be used for scaffolds with hop-up brackets.
- Not to be used for sheeted scaffolds.
- Foot ties mean that a full level of ledgers and transoms is fitted at the lowest cup level.

Bracing and Tying-in Rules

The following rules for bracing apply:

Foot ties: for 2m lift height plan bracing is required at a frequency of one bay in eight. Plan bracing must only be used in the face-braced bays.

No foot ties: for 2m lift heights plan bracing is required as well as ledger bracing on all standards in the first lift. However, for platform heights up to 10m,

plan and/or ledger bracing can be omitted. For 1.5m lift heights no additional bracing is required.

Typical tie patterns

A. 2m lifts – 8m tie pattern

Horizontal spacing every standard

Vertical spacing – maximum 8m

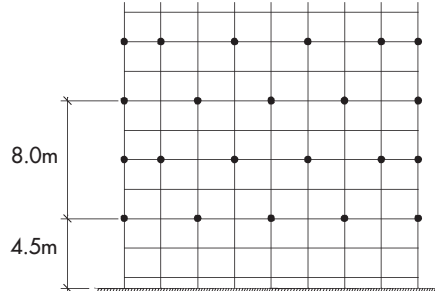

If ties cannot be positioned in the correct place or have to be moved, then bracing has to be used between adjacent ties. If this is done using plan bracing, the maximum horizontal distance between ties is 7.5m. If done using Ledger Bracing the maximum vertical distance between ties is 12.0m.

B. 2m lifts – 6m tie pattern

Horizontal spacing every standard

Vertical spacing – maximum 6m

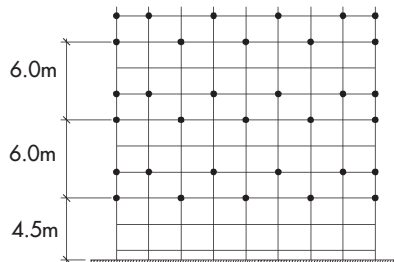

See notes for Tie pattern A but Horizontal is 7.5m and Vertical is 10m

C. 1.5m lifts – 4.5m tie pattern

Horizontal spacing every standard

Vertical spacing – maximum 4.5m

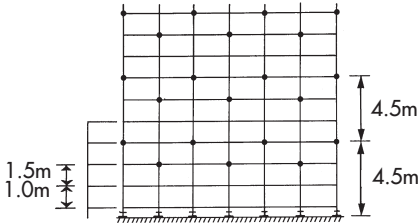

See notes for Tie pattern A but Horizontal is 7.5m and Vertical is 9m

D. 1.5m lifts – 6m tie pattern

Horizontal spacing every standard

Vertical spacing – maximum 6m

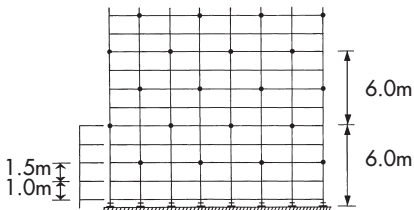

See notes for Tie pattern A but Horizontal is 7.5m and Vertical is 9m

Levels above last tie

2m lift scaffolds can have only one working lift above the last tie and this lift must have ledger bracing. On 1.5m lift scaffolds, one working lift up to 2 lifts above the last level is permitted but both lifts must be ledger braced.

Further information

There is a variety of literature available for the Cuplok Products range. All are available from your local branch.

- Cuplok and Cuplok 3000 Scaffold Systems Brochure
- Formwork Products and Services Manual
- Cuplok 3000 Scaffold System User Guide
- Cuplok Falsework User Guide (Formwork only)
- Tie and Anchors User Guide
- Cuplok Users Manual

Product Range

SGB issues the following User Guides for its product ranges.

Please contact your local branch on 08705 288 388 if you would like to receive any.

Alternatively, you can download them from our website, www.sgb.co.uk

BOSS GRP Towers

BOSS Roommate

BOSS Stairway Towers

CUPLOK Scaffold System - Access

CUPLOK Scaffold System - Falsework Support

CUPLOK Scaffold System in use with Safety Harnesses

COVERSPAN Temporary Roofing System

ENVIROWRAP Shrink Cladding System

EXTRAGUARD Edge Protection System

Fencing and Barriers

GASS Shoring System

Groundworks

Hoarding Panels

Ladders and Steps

Mobile Anchor

Props

Rollafloor Temporary Flooring

Rollaroad Temporary Roadway

ROOFGUARD Edge Protection System - Permanent

ROOFGUARD Edge Protection System - Temporary

Scaffold Tube, Fitting and Ladder Beam

Scaffolding Anchor and Tie

Spandeck, Stagings and Superboards

All information in this User Guide is correct at the time of going to press.

SGB Services Limited reserves the right to change products details or withdraw products at any time.

© This brochure and its contents are the copyright of SGB Services Limited

For further information on this product or any other products and services, please contact your local branch:

tel: 08705 288 388 email: info@sgb.co.uk www.sgb.co.uk

SGB Group

Harsco House, Regent Park, 299 Kingston Road, Leatherhead, Surrey KT22 7SG
Tel: 01372 381300