



# **HUMANE CONTAIN**

## **Model HC-7000**

### **Super Electronic Dog Fence**



## **INSTALLATION, OPERATING AND TRAINING MANUAL**

Please read this entire manual and study all illustrations  
before you begin installing your system

Your new Humane Contain, HC-7000 Professional Series Electronic Dog Fence represents the most advanced state of the art pet containment technology available today. This all new product features a super advanced transmitter, ultra-slim radio collar and our proprietary Pulsed Proportional Stimulus System, a unique combination of progressively increasing sound and shock stimuli to train your pet quickly and safely. The HC-7000 is designed to be EFFECTIVE, RELIABLE and most of all, HUMANE .

**Effective:** Because IT WORKS!

**Reliable:** Because it is manufactured to the highest quality standards.

**Humane:** Because it uses a completely new type of stimulus that focuses on *teaching* rather than *punishing* your pet.

Please read this manual thoroughly to learn how to most effectively, and safely use this advanced system to create a safer, more secure environment for you, your family and your cherished pet.

# Table of Contents

<b>PART 1 – INTRODUCTION</b> .....	4
SYSTEM COMPONENTS: .....	4
KEY FEATURES: .....	4
<b>PART 2 - DETAILED SYSTEM DESCRIPTION</b> .....	7
HC-7000A BASE STATION TRANSMITTER .....	7
RC-7 ULTRA-SLIM RECEIVER COLLAR .....	9
INSTALLING/REPLACING RC-7 THE BATTERY PACK .....	11
BOUNDARY WIRE .....	12
<b>PART 3 - STEP BY STEP INSTALLATION</b> .....	13
Planning Your System Layout .....	13
Assembling the Required Tools .....	19
Setting Up the Base Station Transmitter .....	19
Testing the Receiver Collar Radio Function .....	20
Preparing Twisted Wire Lengths .....	20
Laying Out the Boundary Wire .....	20
Testing Your System .....	21
Burying the Boundary Wire .....	21
Placing the Boundary Flags .....	22
Fitting the Receiver Collar to Your Dog .....	22
<b>PART 4 - TRAINING YOUR DOG</b> .....	23
<b>PART 5 – IMPORTANT CAUTION NOTICES</b> .....	25
<b>PART 6 – WARRANTY &amp; CUSTOMER SUPPORT</b> .....	26
<b>PART 7 – TROUBLESHOOTING PROCEDURES</b> .....	27
Testing Base Station Transmitter .....	27
Testing Humane Contain Collars .....	27
Testing the Containment Loop .....	28
Repairing a Broken or Intermittent Containment Loop .....	29
<b>ACCESSORIES</b> .....	29

# PART 1 – INTRODUCTION

## SYSTEM COMPONENTS:

Your HC-7000 System includes the following items.

- (1) Model HC-7000A Transmitter Base Station
- (1) Model RC-7 Receiver Collar
- (1) DC Adapter
- (500 feet) High Quality Boundary Wire
- (50) Boundary Flags
- (3) Improved Waterproof Wire Splices
- (1) Replaceable Receiver Collar Battery Packs
- (4) Mounting Screws (for your transmitter)

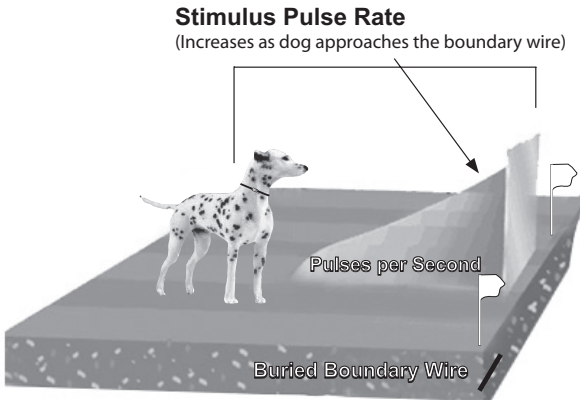

Figure 1

## KEY FEATURES:

**Pulsed Proportional Stimulus:** Our unique *Pulsed Proportional Stimulus System* is what makes the HC-7000 system stand apart from all other systems made. A computer chip inside the RC-7 receiver collar actually detects the distance of your pet from the boundary wire by measuring the relative radio signal strength. It then applies a combination of sound and shock stimuli in inverse proportion to the distance from the boundary wire. In other words, the closer your pet is to the boundary wire, the more sound and shock stimulus is applied.

# How Pulsed Proportional Stimulus Works:



**Figure 2**

The unique shock stimulus used by your HC-7000 system is delivered in short, intense pulses, not a continuous shock. The pulsed stimulus gives your dog a chance to think and avoids sending the animal into panic.

As your dog first comes within the outermost boundary area, a slow beeping tone is sounded and a short duration shock pulse is applied at a slow pulse rate. This first pulse is a FULL VOLTAGE stimulus but, it is of very SHORT DURATION. It will immediately get your dog's attention but, it is so short that your dog will probably not perceive it as painful.

If, instead of retreating, your dog continues to travel closer to the boundary, the shock pulse RATE continues to increase along with an increasing rate of sound pulses, until they are delivered in such rapid succession as to be unbearable to your pet, encouraging retreat from the boundary into the "safe haven" of your yard. The use of progressively increasing shock pulse rate is a very humane technique because it allows your pet to decide for itself how much stimulus is required to initiate the retreat behavior.

(Note that some competing systems use a "tone only" warning zone before applying shock. This sounds like a good idea, but we have found it to be ineffective. Often the dog will stand in the warning zone waiting for the tone to stop. The tone will drain the battery and stop when the battery runs down, letting the animal know it is now safe to escape!) The HC-7000 is not a zone type system. We apply a short shock stimulus at the very first correction along with the sound stimulus. This will discourage your dog from standing in the boundary field waiting for the tone to stop. However, because we use pulsed stimulus, the initial shock will not be traumatic to your pet. If your dog tries to move forward, pulse rate is immediately increased to encourage retreat behavior.

**Progressive Training Tones:** The use of progressively increasing sound pulses along with the shock pulses tends to psychologically intensify the perceived stimulus, more quickly teaching your dog that the irritating

sensation increases as he (or she) gets closer to the boundary. That is why you will find that the tone generated by our RC-7 collar is louder than the non-progressive tones used on competing systems and that the sonic pulse rate increases just as the shock pulse rate does as your dog moves closer to the boundary wire.

**Digital Signal:** The HC-7000 sends a digital code embedded in the radio signal that is picked up and digitally decoded by a computer processor in the receiver collar. This reduces the possibility of false shocks caused by interfering radio signals.

**Visual and Audible Cable Break Indicators:** You are always assured that your boundary wire is intact because the Base Station Transmitter is equipped with both visual and audible cable status indicators to alert you in the case of a cable break.

**Optional Battery Back Up:** If there is ever an electrical power failure, your HC-7000A transmitter will automatically switch over to battery power. This maintains the boundary field and keeps your pet contained throughout the power outage. When power is restored, the battery will automatically be disconnected.

**20 Acre Range:** The powerful transmitter delivers enough energy to activate a boundary wire nearly ONE MILE long. Allowing you to surround up to 30 acres of property. Note that your system includes 500 feet of wire, enough to encircle approximately 0.4 acres. 30 acre coverage is based on wire length of 5,000 linear feet and will require the purchase of additional boundary wire from [www.hightechpet.com](http://www.hightechpet.com).

**Water Resistant Collar:** The RC-7 Radio Collar is internally sealed to resist moisture. While we do not recommend full immersion the RC-7 collar is suitable for outdoor use in all weather conditions.

**For Dogs 10 lbs. to 200 lbs.** The HC-7000 system is suitable for nearly all dog breeds. A common misconception is that larger dogs are more resistant to shock stimulus than smaller dogs. In reality, the size of your dog has little to do with the way the animal reacts to the stimulus. Reaction depends mainly upon your dog's temperament. The type of shock employed by the HC-7000 is quite localized and affects only the nerve receptors within about a ½ inch radius of the stimulus probes. Your dog's mass is not a significant factor. It is also important to note that the shock is high voltage but, very low current. It does not produce enough energy to cause any damage to skin or muscle tissue. The stimulus affects nerve receptors only and simply can not cause physical damage regardless of your dog's size.

## PART 2 - DETAILED SYSTEM DESCRIPTION

### HC-7000A BASE STATION TRANSMITTER

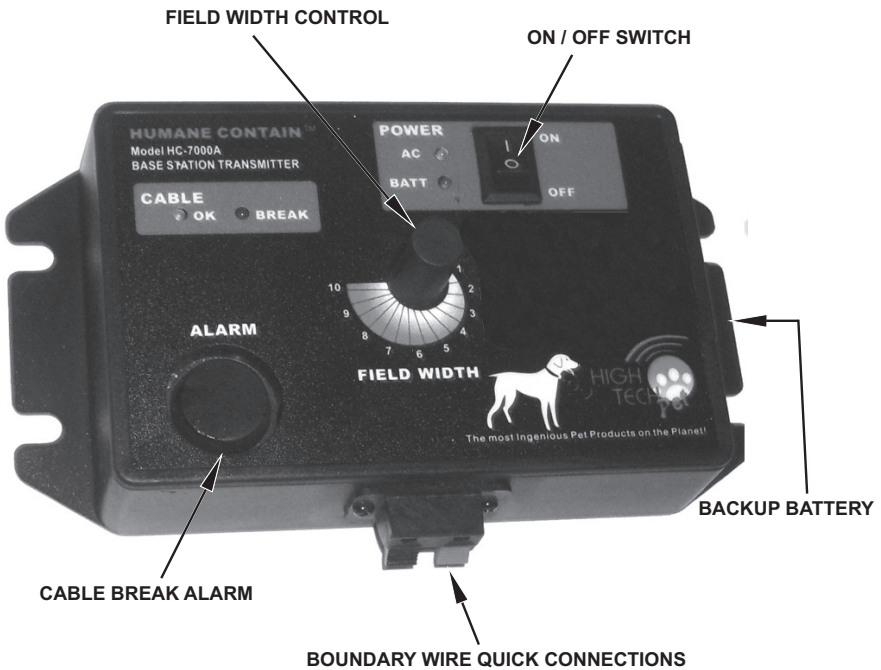

Figure 3

#### General Description

The Model HC-7000A Base Station Transmitter is an FCC approved radio device. (FCC Approval No. QP4HC-5000). The signal emitted by the Base Station Transmitter contains a special, digital code that must be received and recognized by the receiver collar before the collar will administer any stimulus to your pet. The many super advanced features of your HC-7000A Transmitter are as follows.

#### LED INDICATORS:

**CABLE:** The “OK” lamp indicates that there is no break and your boundary wire is conducting current in a continuous loop. If there is a break in your boundary wire, the “BREAK” lamp will illuminate and the audible alarm will sound indicating that the boundary field is not functioning and needs repair.

**POWER:** This indicates the power mode, either AC or Back-up Battery. The HC-7000A Base Station uses a “smart” power system. If you have the optional 9 volt back-up batteries installed and there is a power failure, the system automatically switches to battery mode to keep the boundary field energized and your dog contained. In this mode all indicator lamps flash to conserve battery power. When power is restored, the system automatically switches back to AC mode. The operating time of the Back-up Battery depends upon your field strength setting and the length of your boundary wire. Typical installations will operate for a full day in Battery Back-up mode.

## **Field Strength Control**

You can control the distance from the boundary wire at which the receiver collar will begin to activate by use of the “FIELD WIDTH” dial. Turning the dial clockwise increases transmitter output power and therefore, increases field width. The maximum field width possible will depend upon your particular installation. It is affected by the depth at which you bury the wire and the total length of wire used. The greater the wire depth and length, the less maximum field will be available. Generally, we recommend that you bury your boundary wire no more than 4 inches deep and use no more than 2,500 feet of total boundary wire. Typical installations yield a maximum possible field width of approximately 25 feet. We recommend that you set the Field Width of at least 5 feet. The wider your boundary field, the more time and distance your dog has to properly react to the system. However, if space limitations require a field width of less than 5 feet. You can reduce the overall field width by turning the Field Width dial counter-clockwise. When you vary the effective field width of your system, the HC-7000’s unique Pulsed Proportional Stimulus System will automatically adjust to the new field strength setting.

## **Quick Connect Wire Terminals**

At the bottom of the Base Station Transmitter you will find two quick connect wire terminals. The boundary wire easily plugs into these terminals by simply depressing the tab and inserting the wire end. The wire should be stripped by 1/2 inch at the end before insertion. No other preparation is required.

## **Backup Battery**

On the right side of the BASE station transmitter you will find a compartment to hold two standard 9 volt alkaline batteries for powering the system when AC power is temporarily lost.



## ULTRA-SLIM RECEIVER COLLAR

The heart of our Humane Contain electronic fence technology lies here in the super advanced, Model RC-7 Radio Receiver Collar. The miniaturized, microprocessor-driven circuitry is protected by a rugged, water resistant casing. Shock stimulus is delivered through the STIMULUS PROBES at the back of the unit. A TONE SPEAKER at the front of the unit delivers the tone stimulus.

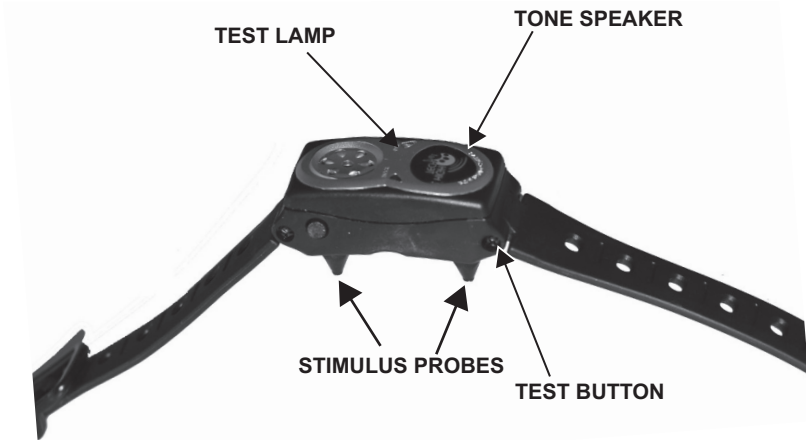

Figure 4

### NORMAL OPERATION

When the TEST button is not pressed, Lamp and Speaker behave as follows:

**Test Lamp:** This lamp illuminates whenever a shock pulse is being generated.

**Tone Speaker:** Emits an audible training tone whenever a shock pulse is being generated.

**Shock Stimulus Probes:** Contact the skin of the pet's neck to administer the shock training stimulus.

## TESTING YOUR RC-7 RADIO COLLAR

**Caution: This test generates actual shock pulses so make sure you remove the collar from your pet and do not unintentionally touch the shock probes!**

Periodically, remove the collar from your pet and perform the following Self Test with the power switch ON. Hold the collar by the case without touching the shock probes, and press the TEST button.

When the TEST BUTTON is pressed the lamp and speaker behave as follows:

### **Test Light:**

- If the test light is SOLID Red the battery is OK.
- If the test light is BLINKING Red the battery is LOW. Replace the battery soon.
- If the test light is NOT ILLUMINATED the battery is dead.

### **Tone Speaker:**

- If the speaker produces an audible tone or beep, the shocking circuit is functioning properly.
- If there is no tone or beep, the shocking circuit is not working and the unit should be repaired .

The water resistant casing is moisture sealed for safe operation in most weather conditions. If the TONE SPEAKER gets wet, you will notice that the tone output becomes muffled or stops altogether. This is due to water on the outside of the speaker face. It does not mean that the inner works have gotten wet. Once the unit dries, the sound will return to normal.

## **INSTALLING / REPLACING THE RC-7 BATTERY PACK**

The replaceable battery pack installs at the bottom of the unit, between the STIMULUS PROBES. Note that there is a small tongue on the battery pack that lines up with a groove in the collar casing. This is to ensure that the battery pack is installed correctly. Line up the tongue with the groove and push firmly. You will hear two clicks as the battery pack snaps into place.

To remove the battery pack, squeeze together the two finger tabs on each side of the battery pack and pull it out of the casing.



**Figure 5**

### **Battery Life**

The battery life of your RC-7 collar depends upon how often your pet strays into the boundary field. It will operate for several weeks in the absence of any required shock output. If your pet is receiving corrections very often, it may be necessary to replace the battery after only one or two weeks. In addition, you should expect to use at least one battery during the initial training.

### **Where to Purchase Replacement Batteries**

Extra battery packs may be purchased online at [www.hightechpet.com](http://www.hightechpet.com). To locate the item go to [www.hightechpet.com](http://www.hightechpet.com) and search on the key words "High Tech Battery".

## **BOUNDARY WIRE**

Even the boundary wire used on your HC-7000 system is unique. The copper alloy wire and insulating coating are all made specially to our custom specifications. We have designed it to be an efficient radio frequency broadcast conductor, with a mechanically strong core and an extra thick, extra tough, outdoor grade insulation that resists sunlight and moisture. If you need to expand your boundary field, it is acceptable to purchase standard 18 or 20 gauge “hardware store” quality wire. However, we recommend that you use our custom wire to ensure the best quality and performance *at the best value pricing*. Boundary extension kits are available from **[www.hightechpet.com](http://www.hightechpet.com)** and contain a 500 foot spool of wire, 50 extra boundary flags and 2 improved waterproof wire splices. To locate the item go to [www.hightechpet.com](http://www.hightechpet.com) and search on “Wire Flag Kit”.

## **PART 3 - STEP BY STEP INSTALLATION**

### **STEP 1: Plan Your System Layout**

This is the most important step. Be sure to take the time to plan carefully. This will avoid time consuming corrections to your installation. Before beginning installation of your system we recommend you make an aerial sketch of your yard such as the one shown in Figure 6. Your sketch should include all buildings, large plants, trees, walks, driveway, pool and other important details. Then sketch in where you plan to place the boundary wire. Make sure the wire makes a continuous loop.

#### **SAFETY TIP:**

Since you will only be burying the cable 4 inches deep at maximum, it is unlikely that you will disturb power or phone lines. Still, we recommend that you contact your utility companies to find out the location of all buried wires, mark them on your sketch and avoid running the boundary cable in these areas.

# TYPICAL LAYOUT FOR BOUNDARIES WITHIN BOUNDARY

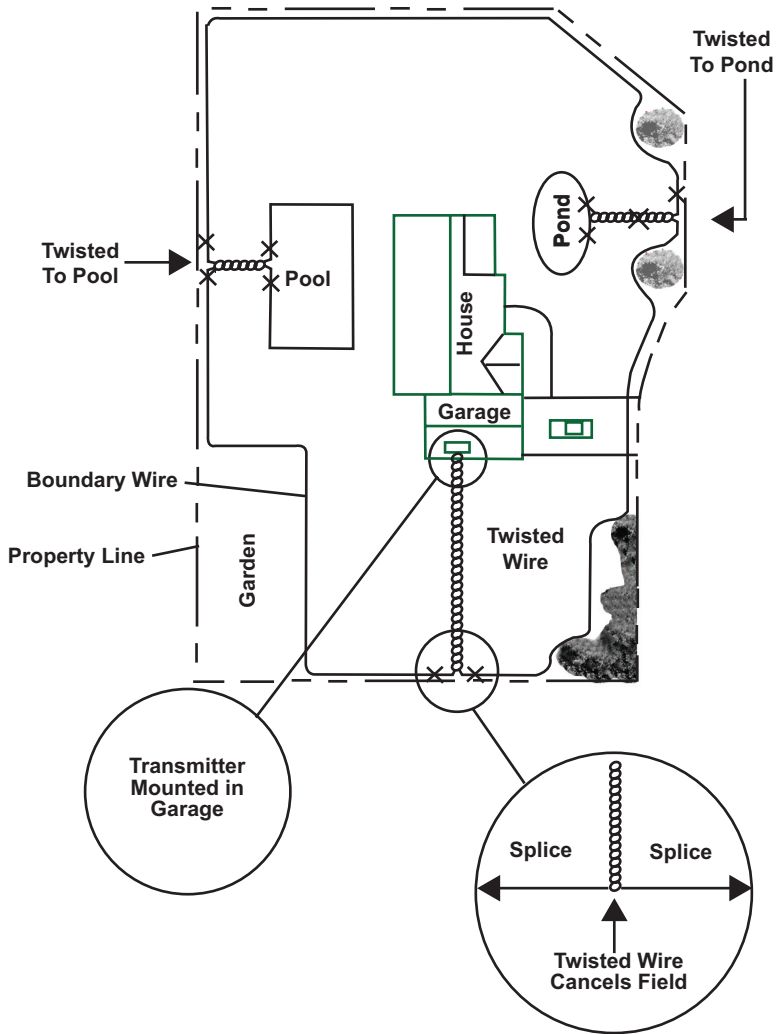
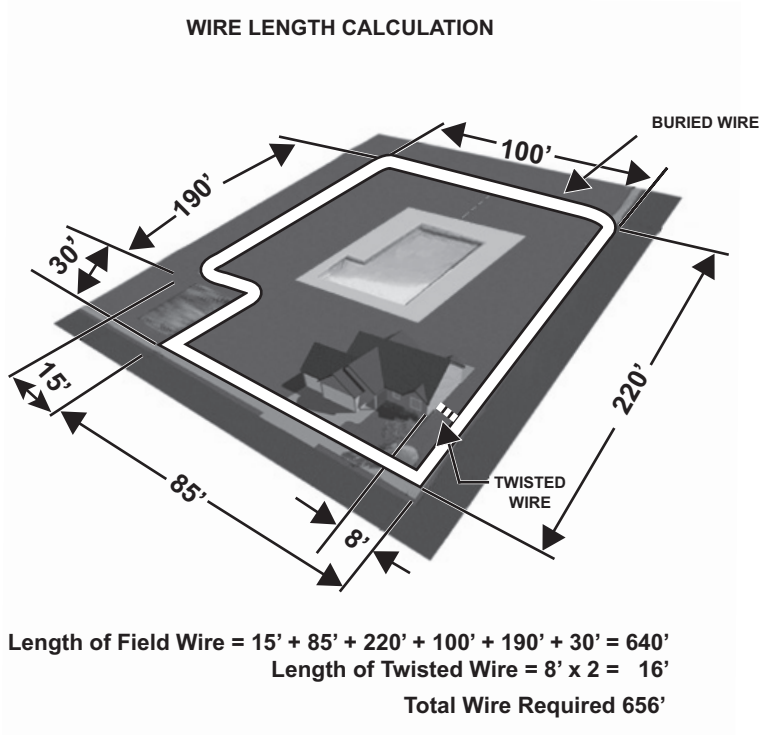

Figure 6

Calculate the total length of wire required to ensure that you have enough to complete the installation. Remember that twisted wire counts as twice its length since there are two strands. Figure 7 shows a basic wire length calculation.

In preparing your layout, note that you will need to allow for a field width of at least 3 feet (preferably 6 – 10 ft.) on each side of the boundary wire. Your dog will need at least another 5 to 10 ft. for a safe roaming area. Avoid making passageways too narrow or your dog may be hesitant to use them.

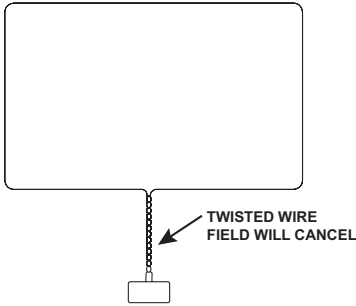

**Figure 7**

For the system to work properly, the wire must make a continuous loop. The signal is transmitted from one terminal of the transmitter through the wire and back to the other terminal. Twisting two adjacent sections of the wire loop cancels the signal along the twisted length. So use the twisted wire from the transmitter out to the exterior loop as shown in Figure 8. This allows the dog to cross the area without receiving a correction. Use other lengths of twisted wire to connect smaller boundaries around plants, pools and other pet restricted areas.

**BASIC CONTAINMENT FIELD**

TWISTED WIRE AS LEAD IN FROM TRANSMITTER TO ACTIVE FIELD



**FIELD WITHIN A FIELD**

USE OF TWISTED WIRE TO PROTECT SMALL AREAS WITHIN THE MAIN BOUNDARY

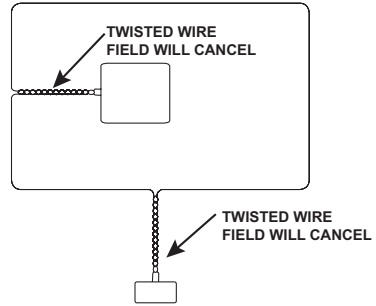

**Figure 8**

**Single Loop Limitations**

Note however that the basic single loop containment layouts shown in Figure 8, cannot have a gate or opening in the fence where the dog can walk or be transported out of the loop. To let the dog out of the basic containment field, you must turn off the base transmitter, or interrupt the electrical signal flowing through the wire by inserting a switch in the loop. Using a switch in the loop creates a break in the wire which will be detected by the base transmitter and will result in an audible alarm as long as the switch is open. However it does work and the dog will learn that the sound of the alarm means the containment field is off.



## Adding a GATE

If you want a permanent opening or gate in the containment field, you must use what is commonly called a double loop, as shown in Figure 9. Carefully follow the current around the wiring and you will realize that this layout is actually still a single loop of wire that is folded back upon itself. If the gate is narrow, you may have to reduce the boundary field next to the gate. This can be done by triangulating or folding the wire back on itself for a short distance as shown inside Figure 9. Do not bury the wire near the gate until after the entire system is working and adjusted for the proper field strength in all areas of the installation. In double loop installations, it is very important to have the inside and outside wires separated

### MAKING A CONTAINMENT FIELD WITH A GATE

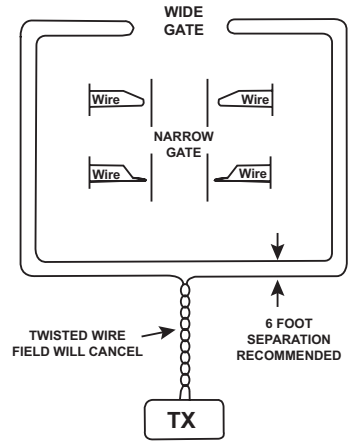

Figure 9

### MAKING A CONTAINMENT FIELD WITH MULTIPLE GATES

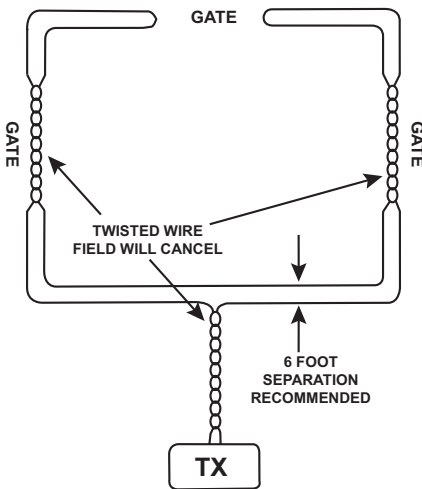

Figure 10

by at least 6 feet all around the containment area if you want a normal containment field width of 3 to 10 feet. Use 12 feet of wire separation if you desire a wider containment field width – up to 20 feet. Using less wire separation reduces the field strength and requires the dog to be closer to the wire before receiving a correction. Whatever wire separation you choose, maintain a consistent separation between the inside and outside wires if you want a consistent correction distance. Remember the double loop requires almost twice as much boundary wire, and burying of that wire, as a single loop, so plan accordingly.

Once you have chosen to use the “double loop” layout, you can

place as many other openings/gates in the boundary field as you wish by twisting the inner and outer wires together, or simply bringing the two wires together tightly. This concept, shown in Figure 10.

**TIP:** The amount of twist and the direction of the twist is of little importance, as long as the wires are touching each other along the entire “gate” section.

## DO NOT DO THIS!

A common error is trying to replace a section of **single** loop boundary wire with a piece of twisted wire to create a **gate** as shown in Figure 11. This will **not** work. In order to create a gate, you must run the boundary wire in a double loop as shown in Figures 9 and 10 above.

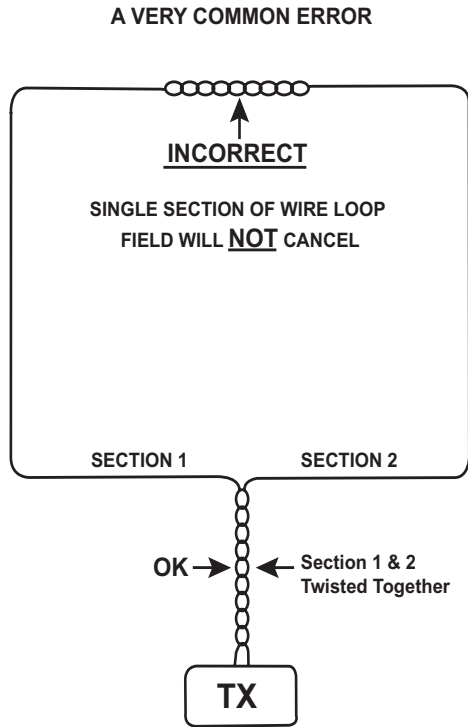

Figure 11

## STEP 2: Assemble the Required Tools

Here is the list of tools you will need.

1. Straight edge spade or power edger
2. Wire cutter/stripper
3. Power drill with 1/8" drill bit
4. Phillips screwdriver or Phillips driver bit for your drill

## STEP 3: Set Up the Base Station Transmitter Mounting:



**FIGURE 12**

The base station transmitter can be mounted to any wall near a 110 volt household wall outlet. Use the four screws provided with your system to mount the unit in a dry and protected area.

## **BATTERY BACKUP**

To install the backup batteries, remove the battery cover on the right side of the transmitter. Install two standard 9 volt batteries onto the battery clips. Replace the battery cover.

**NOTE:** We recommend you replace the batteries when their voltage drops to 8.0 VDC.

**AC Adapter:** Plug the 9 VDC adapter into a standard 115 Volt outlet and connect the DC plug into the receptacle on the right of the Base Station Transmitter.

### **STEP 4: Test The Receiver Collar Radio Function**

You should test the receiver by installing a 24 inch long test loop of wire across the quick connect cable terminals of the HC-7000A. Turn the power switch ON and bring the receiver close to your test loop. A beeping sound emitted by the receiver collar indicates the system is working properly. Note that with such a short loop the range will only be a few inches.

### **STEP 5: Prepare Twisted Wire Lengths First**

Prepare the twisted lengths of wire. From your system layout sketch, determine the length required for each twisted pair. Cut two equal lengths of wire for each required twisted pair. With the pair of wires side by side, put one end of each wire in a power drill and spin the wires until there is approximately one twist per inch of wire. Do not over-twist because this could damage the wire. Repeat for each required pair.

### **STEP 6: Layout the Boundary Wire Above Ground**

Before burying your boundary wire, we recommend that you run the complete loop of wire, make all connections and use the receiver collar to fully test the system with the wire above ground. Referring to the sketch you made of your system layout, run and connect the wire loop above ground, connect it to the Transmitter Base Station.

**Installation Tip:** Leave a little (about 15 inches) slack in the wire periodically along the perimeter and at the corners of the layout so you have a little extra wire when needed to repair a break in the boundary wire loop. Wind the 15 inch slack into a 5 inch diameter coil and bury it with the wire. Choose locations for the slack that are easily identified by a terrain feature and make a map of them.

**Splicing the Boundary Wire:** To join two lengths of boundary wire or connect the loop to pre-twisted wire, use the included “no strip” splices as follows.

1. Push the two ends of the insulated wires to be joined into the outer two holes in the splice. View from the bottom to make sure the wires are fully inserted.



2. Using pliers squeeze the top black button down solidly until it bottoms out.

Additional splices are available from [www.hightechpet.com](http://www.hightechpet.com)

### **STEP 7: Test Your System**

Switch the Base Station Transmitter ON, and set the Field Width to maximum. Power the collar by pressing the battery in flush. Buckle the collar strap to itself forming a loop with the strap. Loosely grasp the strap with your hand and let the collar hang down toward the ground. Now, walk the entire boundary ensuring that the collar continues to beep along the entire perimeter. Also check the lengths of twisted wire to make sure that the field is inactive in the areas where they are used. If the collar picks up a signal from the twisted length, the basic layout is probably incorrect – review the discussion of single and double loop layouts. If you are using a single loop layout, twisted wire can only be used at the base station, or at the feed from the primary boundary wire loop to another primary loop (example: small loop within a large loop).

### **STEP 8: Bury the Boundary Wire**

You do not have to bury the wire for the Humane Contain System to operate however, for protection of the wire, we recommend that you bury it at least 2 inches, and no more than 4 inches deep. Using a flat spade or rotary blade power lawn edger, make a narrow trough around the path of the loop. Using gradual turns at the corners will produce a more consistent signal field. Because of its advanced digital electronics, stray radio signals are unlikely to cause false activation of the collar. However, we recommend that you stay at least six feet away from electrical, telephone, cable TV and other buried wires. These can cause attenuation or dead spots in your field. Large metal objects may create reflected signals from the boundary wire itself. You should avoid running the wire near such structures. If your neighbor has an electronic dog fence you should bury the wire at least ten feet away.

## **Crossing a Driveway or Walk**

When crossing a driveway or sidewalk, you may be able to find an expansion joint into which you can place the wire. Remove any caulk material in the joint, place the wire and re-caulk. If an expansion joint is not available, you can make a ½ inch deep narrow slit across the drive or walk using a circular power saw and masonry blade. Place the wire in the slit and seal with outdoor silicone caulk of matching color. Use asphalt sealant for asphalt driveways. Another option is High Tech Pet's new optional Driveway Traverse Strip, which easily crosses driveways and walks with your electronic fence wire. This durable rubber slit attractively covers and protects the pet fence wire. You can drive over it, walk over it, even mow over it with no damage to the underlying boundary wire. Made of super durable elastomer, that will last years and years, it takes only minutes to install. To order, go to [www.hightechpet.com](http://www.hightechpet.com) and search "driveway traverse strip".

## **Crossing Gravel**

When crossing gravel, run the wire through a hose or PVC pipe and then bury at least three inches deep.

## **Crossing Water**

To cross a stream or body of water, run the wire through a hose or PVC pipe. Anchor each end using large rocks or other stationary objects.

## **STEP 9: Place the Boundary Flags**

Boundary flags are provided so that your pet can easily see the boundary perimeter. This is especially important during training. Flags should be placed along the entire perimeter spaced no more than ten feet apart. Using a fully matching color. Use asphalt sealant for asphalt driveways.

## **STEP 10: Fit the Receiver Collar to Your Dog**

- A. For the receiver collar to properly apply the corrective shock stimulus, it is very important that the electrodes make good contact with the animal's skin. Fur between the electrodes and skin can greatly reduce the amount of stimulus transmitted to your dog. For this reason, we recommend that you shave the fur under your dog's neck where the electrodes contact the skin.
- B. Place the collar around your dog's neck with the receiver housing at the bottom.
- C. Fit the strap as snugly as possible without restricting breathing.
- D. Make sure both electrodes are in good contact with your dog's skin. Use of a little skin lotion on your dog's neck will improve contact.
- E. Once you have determined the proper fit, mark the strap and cut off the excess length.

## **PART 4 - TRAINING YOUR DOG**

Training your dog will require use of a separate restraining collar and short training lead. Do not use the RC-7 radio receiver collar as a restraining collar. Structure your training program to three, fifteen-minute sessions per day, EVERY DAY until your dog is fully trained. Stick to this program consistently but, do not train for more than fifteen minutes at a time or you risk losing your dog's attention and the training becoming counter productive. Remember that the most important elements in teaching a behavior are consistency and repetition.

### **STAGE 1 TRAINING**

Stage 1 training takes place in the outer edge of the boundary field.

- A. Choose a Command: You should choose a specific verbal command to instruct your dog to retreat, such as "Retreat," "Back" or "Home." Use this command exclusively and consistently throughout the training.
- B. With boundary flags in place, field fully operational and a fully charged Receiver Collar on your dog, use the training lead to escort your dog into the outer edge of the boundary field. When you hear the beeping tone, utter the retreat command while firmly tugging on the lead and lead your dog into the safe zone. Use encouraging words such as, "Good Dog!" Praise and pet your dog. You may also wish to give your dog a food treat.
- C. Repeat this stage for fifteen minutes each session until your pet instinctively and immediately retreats the moment the training tone is heard.

### **STAGE 2 TRAINING**

In Stage 2 training you will lead your pet right up to a boundary flag introducing the most rapid pulse rate stimulus. As unpleasant as this stage may seem, it is extremely important that you teach your pet how to react to the intense stimulus. Otherwise, your dog may become confused and cower in the correction field or instinctively run the wrong way through the field. Bear in mind that you do not want to let your dog in on the knowledge that the stimulus field is only a few feet wide. Let him think it continues forever.

- A. With the training lead tightly in hand, escort your dog right up to the boundary flag where the stimulus will be most intense.
- B. The instant your dog reacts, utter the retreat command and escort your dog into the safe zone. Use encouraging words, praise and pet your dog and give the animal a treat as before.

- C. Repeat this stage for fifteen minutes, three times per day until there is no doubt that your dog has “Got it,” observing your dog’s resistance to entering the boundary field or trying to retreat before the stimulus is received. These are good signs.
- D. Observe your pet: Once you are certain that your pet will INSTINCTIVELY retreat at the first training tone, allow the animal to roam freely and observe his behavior. Make sure that you see him stop at the boundary flags on his own. If your dog shows the slightest sign of confusion or stubborn behavior, continue the training program using the lead. It’s okay to return to Stage 1 training if you think it is appropriate.



## PART 5 – IMPORTANT CAUTION NOTICES

**Dogs are Unpredictable:** Because individual dogs have unique temperaments, there is no way of knowing how your dog will react to its introduction to the training program. For your safety and your dog's, initial training must take place using a training lead so that you keep complete control over the situation. Also realize that an aggressive animal could turn against the handler upon receiving the shock stimulus. Therefore, if you feel your dog has an aggressive behavior or has ever exhibited evidence of such behavior, we strongly suggest that you consult a certified animal behaviorist before using this product as a training aid.

**Skin Conditions:** A small percentage of dogs may experience a skin condition called pressure necrosis, also known as contact dermatitis, caused by the pressure of the two probes against the same place on the dog's neck for an extended period of time. This condition causes an infection, creating irritation and sores. We recommend you check your dog's neck often to ensure that no such condition is evident. If your dog has a history of sensitive skin, eczema, skin allergies or rashes we recommend that you do not use an electronic fence collar to contain an animal. If you do observe a skin irritation, take your dog to a veterinarian who may prescribe a local ointment to clear up the condition. Bear in mind that it is not possible for the shock stimulus emitted by the RC-7 collar to directly damage your pet's skin. The electrical current output is simply too low to cause burning, or any other type of cellular, skin or organ damage. The stimulus excites nerve receptors only.

**Neurological Conditions:** In extremely rare cases, animals may have neurological disorders such as epilepsy. You should be certain that your dog does not suffer from such a disease before using any type of sonic, or shock stimulus training collar. Also, make sure that your dog does not suffer from heart disease or any other chronic condition and be assured that your pet is in generally good health before using this product.

## **PART 6 – WARRANTY & CUSTOMER SUPPORT**

Your Humane Contain Model HC-7000 is the best made electronic fence you can buy and it's covered by the best warranty. If anything goes wrong with your product within one year of purchase, you may return it to us for a free replacement. For customer support, where you can get product information, warranty support, tech support and order accessories, visit:

**[www.hightechpet.com](http://www.hightechpet.com)**

## **PART 7 – TROUBLESHOOTING PROCEDURES**

If any part of the system is not working use the following troubleshooting procedure to isolate the failed component. Then contact High Tech Pet Products Customer Support to get it repaired or replaced.

### **1) Test Base Station Transmitter**

- a) First disconnect the boundary wire loop from the base station transmitter by lifting the small door on the bottom of the transmitter and pressing the two wire connection buttons (one is black the other is red) while pulling gently on the wires.
- b) Apply power to the transmitter and verify that the BREAK DETECTION circuit indicates a break. There will be an audible alarm and an LED on the transmitter face. If a break is NOT indicated, the base station transmitter has failed – repair or replace.
- c) Make a Test Loop Wire as follows: Strip 1/2 inch of insulation from the two ends of a 24 inch long piece of spare insulated wire. You can use any gauge wire.
- d) Attach the Test Loop Wire to the containment wire terminals (black and red) on the bottom of the transmitter. Apply power to the transmitter and verify the BREAK DETECTION circuit does NOT indicate a break. There should be no audible alarm and no Break LED. If a break is detected the Base Station Transmitter has failed – repair or replace.

### **2) Test all Humane Contain Collars**

- e) With the TEST Loop Wire attached and the transmitter powered adjust the Field Strength Control knob to maximum (fully clockwise). Now bring one collar at a time close to the Test Wire Loop and verify the collar is triggering. If you hear a beeping tone and see a flashing red light on the face of the collar the collar is working and the Base Station Transmitter is working, so go to step 3) to verify the loop.
- f) If you do not hear a beep and see a flashing light on the face of the collar then either the collar, or the transmitter, or both have failed. Let's try to isolate the problem down to a single component.
  - If you have another collar, repeat step g) on that collar. If that collar passes the test then that collar and the Base Station Transmitter are OK, and only the first collar is failed – repair or replace just the first collar.

- If you have a friend who also owns a High Tech Pet Humane Contain system that is working, test your collar(s) on their operating system by holding your collar next to their collar in the yard. As you move both collars toward the wire loop both collars should beep at about the same rate. If this is true your collar(s) is working and your Base Station Transmitter has failed – repair or replace.
- g) If you cannot determine which component has failed, return both the collar(s) and the Base Station Transmitter to High Tech Pet Products for analysis and repair.

### **3) Test the Containment Loop**

- h) Once you have verified the components are working using steps 1) and 2) above, disconnect the Test Loop Wire and re-connect the containment wire loop to the Base Station Transmitter. Place the working collar on the ground about five feet from the wire, in a “clean” area of the yard. Clean means with the least amount of metal or concrete nearby (concrete may contain metal re-bar). This area should be free of underground pipes if possible.
- i) Lay the collar face down on the ground.
- j) Turn ON the Base Station Transmitter, and adjust the Field Strength Control Knob to maximum (fully clockwise). If the BREAK DETECTION indicates a break then the loop is broken and needs repair. Go to step 4).
- k) The collar should now be beeping and flashing a red light on the face of the collar. If not, the loop is intermittent and needs repair. Go to step 4).
- l) Slowly adjust the Field Strength Control Knob on the transmitter counter clockwise until the collar stops beeping. If the collar is still beeping when the Knob is fully counter clockwise, the Base Station transmitter is faulty – repair or replace.
- m) Slowly adjust the Knob clockwise and note the beeping starts at a rate of about one beep every half second. Continue slowly adjusting clockwise and note the beeping rate increases to two short beeps every half second. Continue slowly adjusting clockwise and note the collar beeping at an even higher rate that sounds like a string of beeps every half second. This means the loop and the entire system are working properly. If not the loop is intermittent. Go to step 4).

#### 4) Repairing a Broken or Intermittent Containment Loop

There are many ways to approach repairing a faulty loop depending on the length of wire, the number of connections, the terrain, available equipment, etc. Please contact technical support at [Techsupport@HighTechPet.com](mailto:Techsupport@HighTechPet.com) for a list of methods.

#### ACCESSORIES AVAILABLE AT [WWW.HIGHTEHPET.COM](http://WWW.HIGHTEHPET.COM)



**Extra Collar:** Model RC-7, Extra Radio Collar. Got extra dogs? You may add an unlimited number of extra collars to your HC-7000 system.

**Extra Collar Battery Pack:** Model BPK-3V8. It's a good idea to keep several of these inexpensive battery packs handy to ensure that your system is always working.



**Boundary Extension Kit:** Expand your boundary perimeter . Includes 500 feet of heavy duty wire, 50 flags and 2 improved waterproof wire splices.

**Radio Mat Scat Pad:** This unique accessory has a built-in radio transmitter that activates your dog's RC-7 collar at the touch of a paw to keep Fido off the couch, away from the trash or out of any off limits area. Measures 12" X 60". Made of durable, washable nylon. .





2476 Palma Drive, Suite A  
Ventura, CA 93003  
info@hightechpet.com

See our complete line of ingenious pet products at **[www.hightechpet.com](http://www.hightechpet.com)**

Humane Contain is a trademark of High Tech Pet Products, Inc.  
Manufactured in China

**Engineered in the USA!**



**High Tech Pet Products, Inc.**  
2476 Palma Drive, Suite A  
Ventura, CA 93003  
[www.hightechpet.com](http://www.hightechpet.com)