

Cobalt Digital Inc.

**9990-ENC-H264-IP Dual-Channel Encoder with
Streaming IP Output**

Product Manual

Version 2.4



9990-ENC-H264-OM
Version: 2.4



9990-ENC-H264-IP • Dual-Channel Encoder with Streaming IP Output Product Manual

- Cobalt Digital Inc. Part Number: **9990-ENC-H264-OM**
- Document Version: **2.4**
- Printed in the United States.
- Last Author: CGG
- Printing Date: 8/24/2015

The information contained in this manual is subject to change without notice or obligation.

Copyright



© 2015 Cobalt Digital Inc. All rights reserved.

Contents of this publication may not be reproduced in any form without the written permission of Cobalt Digital Inc. Reproduction or reverse engineering of copyrighted software is prohibited.

Notice

The material in this manual is furnished for informational use only. It is subject to change without notice and should not be construed as commitment by Cobalt Digital Inc. Cobalt Digital Inc. assumes no responsibility or liability for errors or inaccuracies that may appear in this manual.

Trademarks

-  is a registered trademark of Ross Video Limited.
-  is a registered trademark of Cobalt Digital Inc.
- DashBoard Control System™ is a trademark of Ross Video Limited.

All other product names and any registered and unregistered trademarks mentioned in this manual are used for identification purposes only and remain the exclusive property of their respective owners.

Important Regulatory and Safety Notices

Before using this product and any associated equipment, refer to the “**Important Safety Instructions**” listed below to avoid personnel injury and to prevent product damage.

Products may require specific equipment, and/or installation procedures to be carried out to satisfy certain regulatory compliance requirements. Notices have been included in this publication to call attention to these specific requirements.

Symbol Meanings



This symbol on the equipment refers you to important operating and maintenance (servicing) instructions within the Product Manual Documentation. Failure to heed this information may present a major risk of damage or injury to persons or equipment.



Warning — The symbol with the word “**Warning**” within the equipment manual indicates a potentially hazardous situation which, if not avoided, could result in death or serious injury.



Caution — The symbol with the word “**Caution**” within the equipment manual indicates a potentially hazardous situation which, if not avoided, may result in minor or moderate injury. It may also be used to alert against unsafe practices.



Notice — The symbol with the word “**Notice**” within the equipment manual indicates a situation, which if not avoided, may result in major or minor equipment damage or a situation which could place the equipment in a non-compliant operating state.



ESD Susceptibility — This symbol is used to alert the user that an electrical or electronic device or assembly is susceptible to damage from an ESD event.

Important Safety Instructions



Caution — This product is intended to be a component product of an 8300 series frame. Refer to the frame User Manual for important safety instructions regarding the proper installation and safe operation of the frame as well as its component products.



Warning — Certain parts of this equipment namely the power supply area still present a safety hazard, with the power switch in the OFF position. To avoid electrical shock, disconnect all A/C power cards from the chassis’ rear appliance connectors before servicing this area.



Warning — *Service barriers within this product are intended to protect the operator and service personnel from hazardous voltages. For continued safety, replace all barriers after any servicing. This product contains safety critical parts, which if incorrectly replaced may present a risk of fire or electrical shock. Components contained within the product's power supplies and power supply area, are not intended to be customer serviced and should be returned to the factory for repair. To reduce the risk of fire, replacement fuses must be the same time and rating. Only use attachments/accessories specified by the manufacturer.*

Maintenance/User Serviceable Parts

Routine maintenance to this Cobalt Digital Inc. product is not required. This product contains no user serviceable parts. If the frame does not appear to be working properly, please contact Technical Support using the numbers listed under the “Contact Us” section on the last page of this manual. All Cobalt Digital Inc. products are covered by a generous 5-year warranty and will be repaired without charge for materials or labor within this period. See the “Warranty and Repair Policy” section in this manual for details.

Environmental Information

The equipment that you purchased required the extraction and use of natural resources for its production. It may contain hazardous substances that could impact health and the environment.

To avoid the potential release of those substances into the environment and to diminish the need for the extraction of natural resources, Cobalt Digital Inc. encourages you to use the appropriate take-back systems. These systems will reuse or recycle most of the materials from your end-of-life equipment in an environmentally friendly and health conscious manner.

The crossed-out wheeled bin symbol invites you to use these systems.

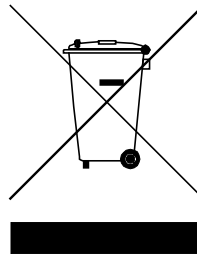

If you need more information on the collection, reuse, and recycling systems, please contact your local or regional waste administration.

You can also contact Cobalt Digital Inc. for more information on the environmental performances of our products.

Contents

Contents	5
Introduction.....	7
Product Overview	7
9990-ENC-H264-IP Indicators and Switches.....	9
Rear I/O Panel Indicators.....	9
Front Indicators.....	10
Front Switches	11
9990-ENC-H264-IP Operation and Management	12
Product Tab.....	14
Network Tab	16
Network Configuration Tab.....	16
Network Configuration Interfaces Tab.....	16
Network Configuration DNS Tab.....	17
Network Statistics Tab.....	18
Network Statistics Interface Tab.....	18
Network Statistics DNS Tab.....	19
Encoder 1, Encoder 2 Tabs	20
Encoder Configuration Tab.....	20
Video Input Auto-Detection	21
Encoder Basic Configuration Tab.....	21
Basic Tab – General Configuration	22
Basic Tab – Video Configuration	23
Basic Tab – Audio Configuration.....	27
Encoder Advanced Configuration Tab	29
Advanced Tab – Video Parameters.....	29
Advanced Tab – VBI/Ancillary Data Insertion	31
Advanced Tab – Audio Parameters	35
Advanced Tab – Mux Parameters.....	37
Encoder Output Tab.....	39
UDP/IP Streaming	40
HTTP Live Streaming.....	41
Direct HTTP Streaming	45
RTMP.....	47
The Apply/Cancel Buttons.....	50
Encoder Statistics Tab.....	51
Encoder Status	51
Output Status.....	55
Admin Tab	59
Admin General Tab.....	59
Admin Firmware Tab.....	60
Admin Config Files Tab	62
User-Saved Configurations.....	63
Pre-defined Templates	64
Clear Current Configuration Button	65

Admin Event Log Tab	65
Support Tab.....	69
Playing Video on a Web Page	70
Web Pages Served by the 9990-ENC-H264-IP	71
Multicast Streaming.....	73
HTTP Live Streaming.....	73
Direct HTTP Streaming	74
Using a Firewall between the 9990-ENC-H264-IP and the Internet	74
Web Browser Support.....	75

Introduction

This manual covers the following products:

- The 9990-ENC-H264-IP openGear® H.264 SD/HD single and dual-channel encoder card

The 9990-ENC-H264-IP has the following features:

- Video Encoding support: up to two channels of SD or HD H.264 encoding, with a maximum resolution of 1920×1080p60 per channel.
- Audio Encoding support: up to two channels of MPEG-1 Layer II or AAC-LC.
- Video Inputs: support for composite, SD-SDI, HD-SDI, and 3G-SDI.
- Audio Inputs: support for balanced or unbalanced analog audio, and SDI embedded digital audio.
- Outputs: 2 Ethernet ports, supporting 100 Mb/s and 1 Gb/s operation.
- Replication: each encoded stream can be replicated on both Ethernet port.
- Support for UDP/RTP on Ethernet.
- Support for Over-The-Top (OTT) protocols: HTTP Live Streaming, RTMP, Direct HTTP.
- Closed-Captioning support (both EIA-608 and EIA-708 captions).
- AFD extraction and insertion support.
- Support for pre-compressed Dolby AC-3 pass-through embedded in SDI inputs.

Typical application scenarios for the 9990-ENC-H264-IP are:

- Video Distribution over IP backbones
- IPTV headends
- Monitoring
- High-Quality OTT generation

Product Overview

The 9990-ENC-H264-IP supports up to two H.264 SD/HD encoders each with one stereo pair of audio encoding. The encoded transport stream can be routed and replicated to both Ethernet ports.

The following inputs are available:

- Software-configurable Composite or SDI video inputs, with auto-detection capability
- SDI video inputs support SD-SDI, HD-SDI and 3G-SDI, with auto-detection capability
- Analog unbalanced audio stereo inputs

- SDI embedded audio support

The following outputs are available:

- Two Ethernet outputs, supporting full-duplex 100 Mb/s and 1 Gb/s operation

A block diagram of the encoder is shown below:

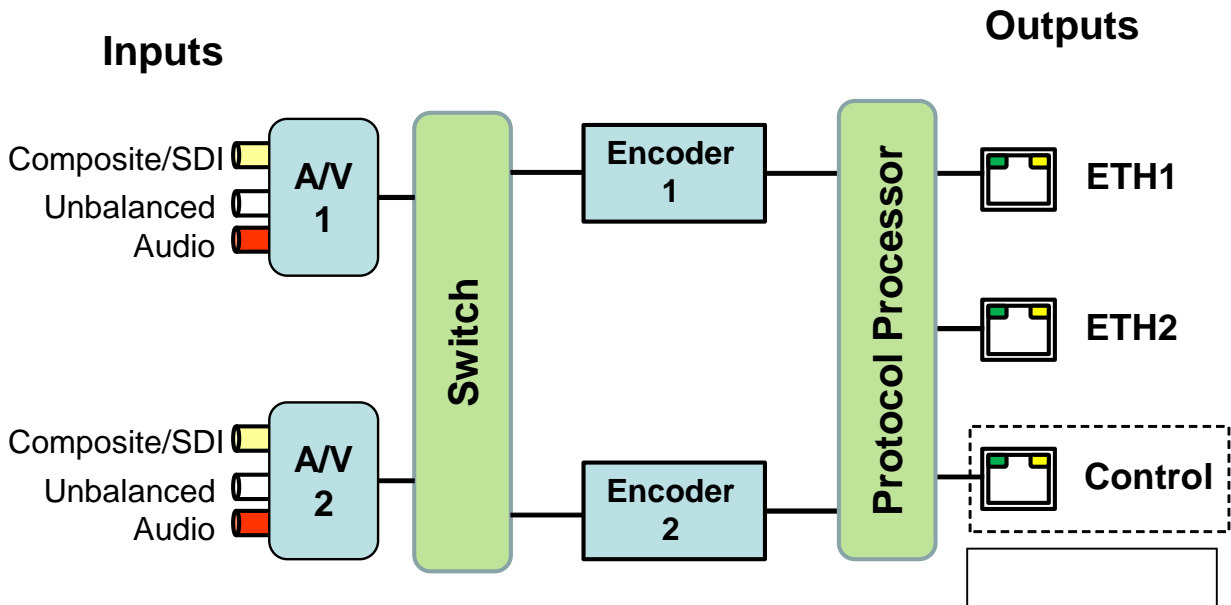

9990-ENC-H264-IP Indicators and Switches

The 9990-ENC-H264-IP card can be installed in 20-slot openGear-compatible frames. Prior to installing the card, first install the corresponding rear panel I/O module. Note that the rear I/O panel for 20-slot frames is **different** from the panel for older 10-slot frames..

Rear I/O Panel Indicators

There are two rear I/O panels available for the 9990-ENC-H264-IP encoder, to support different analog audio inputs:

- Unbalanced Audio I/O Panel
- Balanced Audio I/O Panel

All 9990-ENC-H264-IP I/O panels have two software-configurable Composite/SDI video inputs on standard BNC connectors and two 100/1000 Mb/s Ethernet ports on standard RJ-45 connectors. There also two unused BNC ports. The unbalanced audio I/O panel includes four RCA connectors, and the balanced audio I/O panel includes four terminal blocks. The panels are depicted in the next page.

Each of the video inputs has a green indicator LED, with the following states:

- **LED off:** no video signal detected, or input not configured.
- **LED flashing:** video input locked to the video signal.
 - **LED flashing about once per second:** input video is SD.
 - **LED flashing about twice per second:** input video is HD-SDI.
 - **LED flashing about 4 times per second:** input video is 3G-SDI (1080p60).

Each of the Gigabit Ethernet ports has two indicator LEDs, with the following states:

- **Green LED:**
 - **Off:** No link
 - **On:** Link
- **Yellow LED:**
 - **Off:** No activity (transmit and/or receive)
 - **Flashing:** Port is currently transmitting and/or receiving

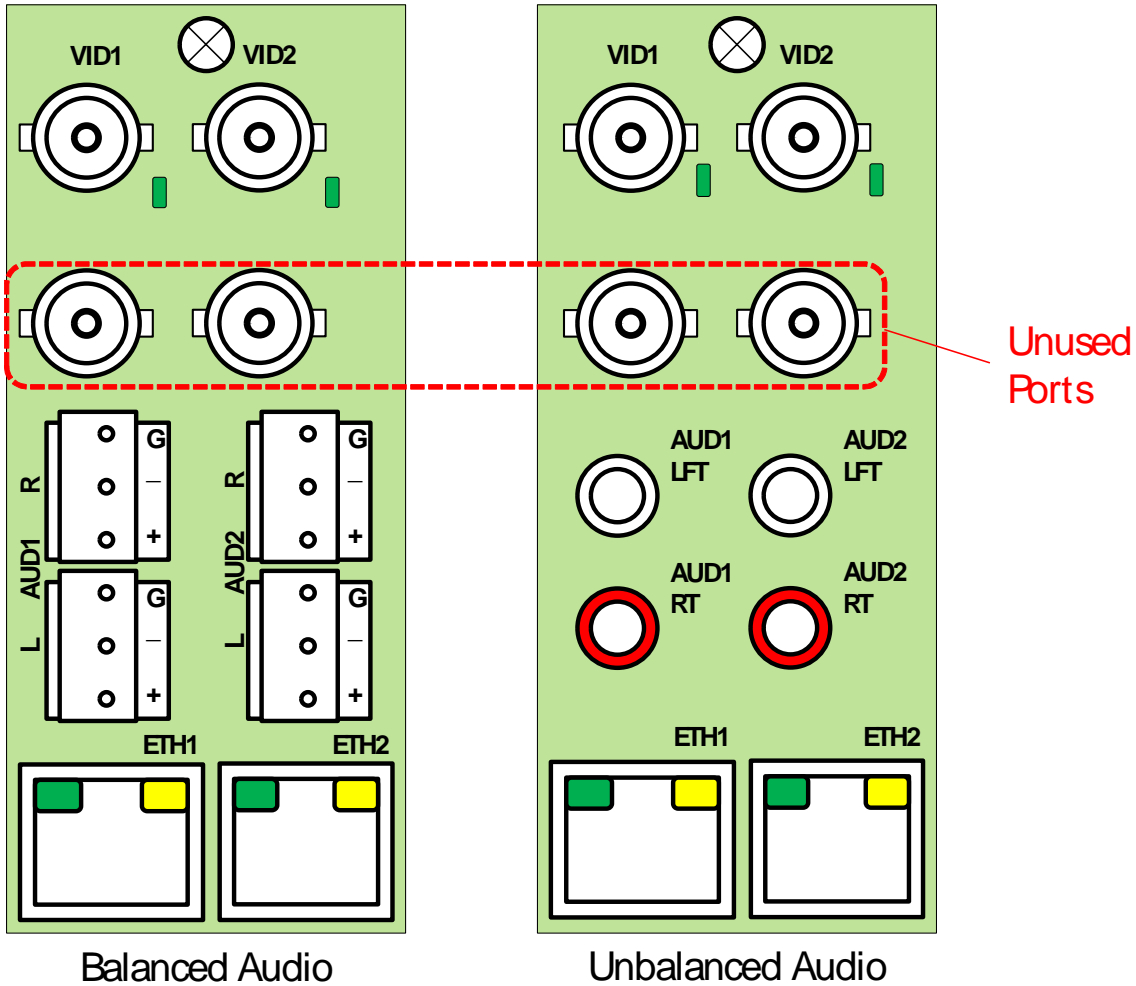

Note that the balanced audio rear I/O panel is only supported on boards with hardware version 4 and higher. The hardware version is available in the Product Tab in Dashboard.

Front Indicators

A similar set of indicators exist in the front of the board. These are visible when the frame front door is opened. The indicator layout is depicted below.

The LED indicators are as follows:

- **Status LED:** indicates the overall status of the board.
 - **Green:** no active alarm
 - **Red:** at least one critical alarm present

When inserting a board in the frame, this LED will be red until the board starts operation. At that point, it will turn green if there is no active alarm or stay red if there is at least one alarm.
- **Power OK LED:** indicates that the power received from the frame is OK.
 - **Green:** power OK
 - **Off:** no power (or insufficient voltage – check the frame power status)

- **VID 1 and VID 2 LEDs:** these behave exactly the same as the corresponding rear I/O panel indicators.
- **ENC1 and ENC2 LEDs:** these LEDs flash if the corresponding encoder is running, with output available for routing to ASI, UDP or RTP. They will not flash if the encoder is stopped (either by explicit configuration or by lack of input) or if it is in one of the Web streaming modes (HTTP Live Streaming or Direct HTTP Streaming).
- **ETH1 and ETH2 LEDs:** these indicate the status of the corresponding Ethernet connection.
 - **Off:** no link
 - **On:** link OK, no activity
 - **Blinking:** link OK, port is transmitting and/or receiving packets

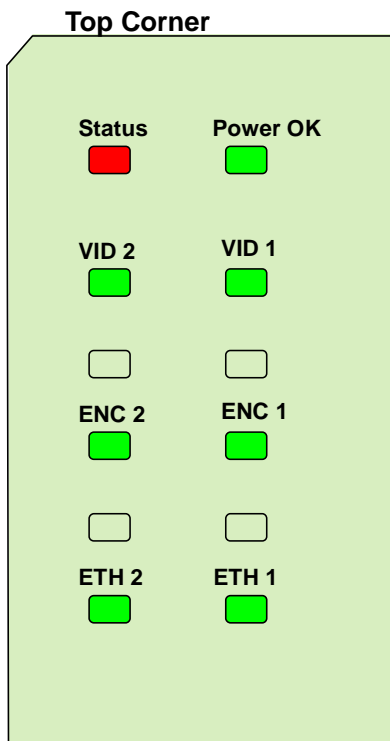

The 9990-ENC-H264-IP board has other LEDs that may or may not be illuminated. They are intended for engineering debug only.

Front Switches

The 9990-ENC-H264-IP board has two pushbutton-type switches in the front, just below the LEDs, as depicted below. Their operation is as follows:

- **Default IP Switch:** This switch is used to recover the board in the unlikely case of a corrupted or broken firmware update. In most cases, the 9990-ENC-H264-IP will detect the error and automatically fall back into the factory-default firmware load. If it does not, pull the card out, press and hold this switch, and push the card back into the frame while

still holding the switch. You can release the switch once the Status LED turns orange. This action causes the card to revert to the factory-default firmware.

- **Reset Switch:** Pressing this pushbutton switch causes the card to reset.

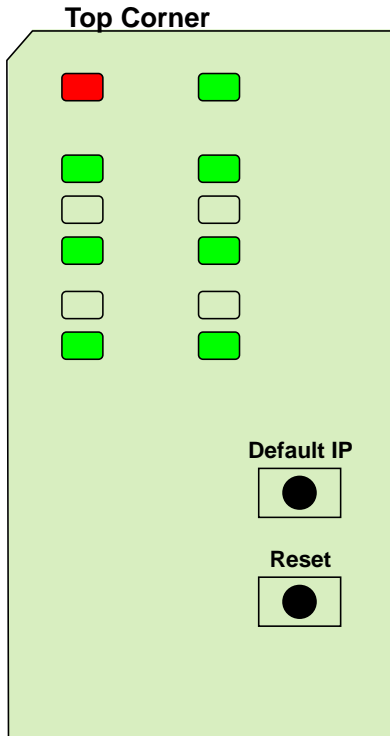

9990-ENC-H264-IP Operation and Management

The 9990-ENC-H264-IP is configured using the free Dashboard™ application, which is available for Windows, Apple OS X, and Linux. Dashboard can be downloaded from this link:

<http://www.opengear.tv/dashboard-software>¹

The 9990-ENC-H264-IP user interface is depicted below. It is divided into a statistics panel on the left, and a configuration panel on the right. Each panel has multiple tabs, corresponding to the various functions in the unit. Note that the **Card State** alarm indicator is also reflected in the green/red **Status** LED in the front of the board. The Status LED will be green when Card State is green or yellow, and will be red when Card State is red.

The following tabs are available:

- **Product:** this tab provides general information on the unit, including firmware version, uptime, temperatures, and other parameters. It appears only on the Statistics panel.

¹

- **Network:** this tab is used to configure the IP addresses and network information for the Ethernet ports. The statistics side of the panel includes some additional information such as link state.
- **Encoder 1, Encoder 2:** these tabs are used to configure the two encoder channels.
- **Admin:** this tab is used for general administrative functions, such as firmware upgrades, licensing, logs, and configuration management. The Test Packet Generator configuration is also found under this tab.

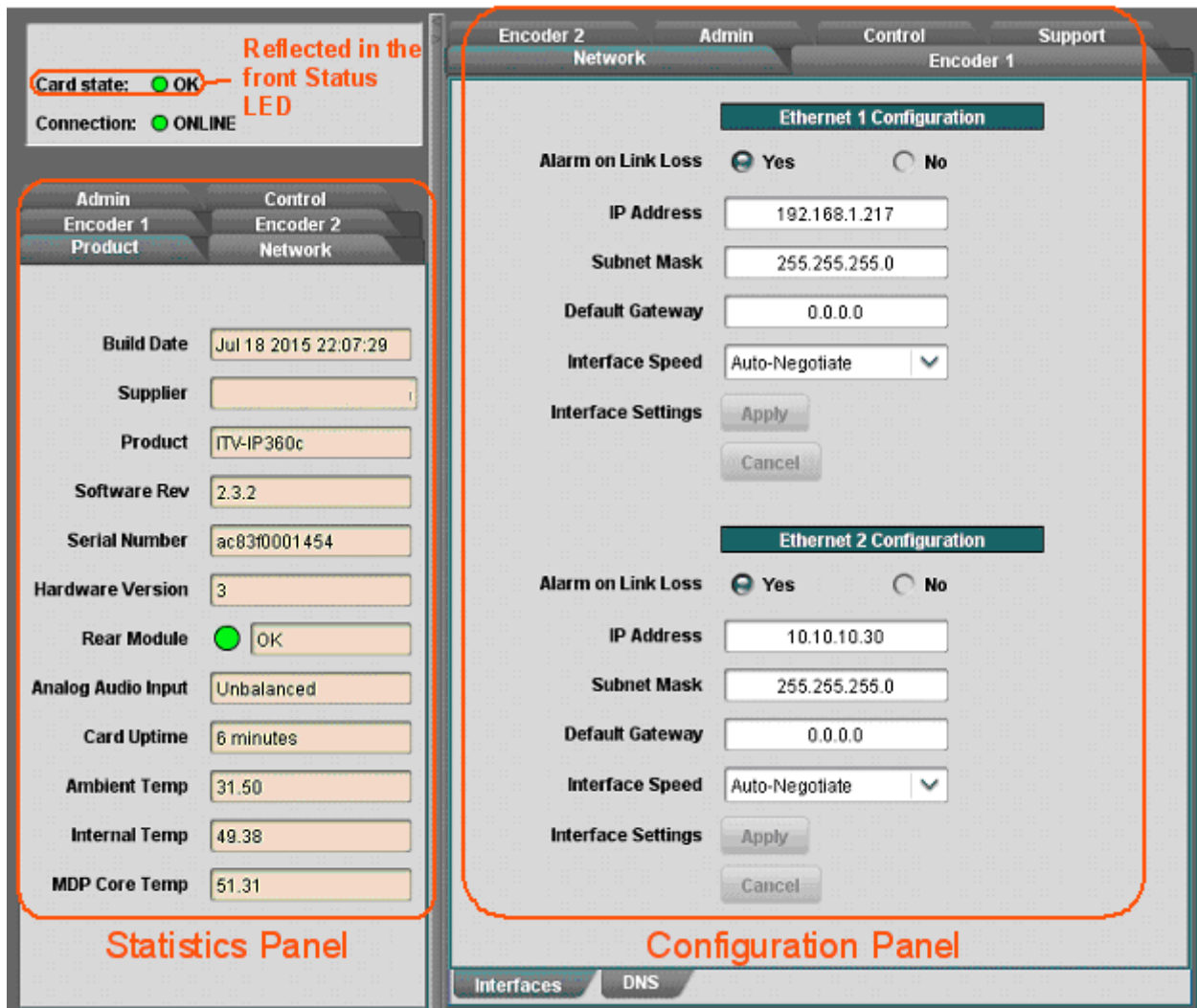



Product Tab

The Product Tab contains basic information about the 9990-ENC-H264-IP.

Admin	Control
Encoder 1	Encoder 2
Product	Network
Build Date	Jul 18 2015 22:07:29
Supplier	Cobalt Digital Inc
Product	9990-ENC-H264-IP
Software Rev	2.3.2
Serial Number	ac83f0001454
Hardware Version	3
Rear Module	<input checked="" type="radio"/> OK
Analog Audio Input	Unbalanced
Card Uptime	12 minutes
Ambient Temp	31.38
Internal Temp	49.56
MDP Core Temp	51.62

The following information is available:

- **Build Date:** Date the firmware image was built.
- **Supplier:** Cobalt Digital Inc.
- **Product:** 9990-ENC-H264-IP
- **Software revision:** This indicates the firmware revision currently running. The format is Major Version • Minor Version • Build Number.
- **Serial Number:** This is the serial number of this particular 9990-ENC-H264-IP unit.

-
- **Hardware Version:** This indicates the board version number. Balanced audio support is available for version 4 and later. All other functionality is the same across hardware versions.
 - **Rear Module:** This indicates the status of the Rear I/O Module. It can have one of the following states:
 -  **OK:** The Rear Module is the correct module for the 9990-ENC-H264-IP.
 -  **Not Installed:** The 9990-ENC-H264-IP is not connected to a rear module. The card is operating normally, but it will not be useful as there are no input and output connections to it.
 -  **Wrong Module:** The 9990-ENC-H264-IP is connected to a rear module that was not designed for it (either from another openGear® vendor or for a different card). Depending on the signals present on that module, there may be a small chance of damage to the 9990-ENC-H264-IP; it is recommended that this situation be rectified immediately. This alarm will cause the front status LED to turn red. A card with hardware version 3 or lower will show this alarm for the balanced audio rear I/O panel.
 - **Analog Audio Input:** This indicates the type of analog audio input (balanced or unbalanced). This field will have an indication of **unknown** for unrecognized/unsupported rear I/O panels.
 - **Card Uptime:** Indicates how long the unit has been running since it was last rebooted.
 - **Ambient Temperature:** Temperature, in degrees centigrade, of the air intake of the unit (measured at the front edge of the unit).
 - **Internal Temperature:** Temperature, in degrees centigrade, at the back of the unit.
 - **MDP Core Temperature:** Temperature, in degrees centigrade, of the core MediaStorm processing element.

The openGear® frame is designed to operate in environments with up to 40°C ambient. There is typically a 5°C temperature raise from the external ambient to the “Ambient Temperature” measured by the 9990-ENC-H264-IP. If that measurement is at 45°C or higher, action must be taken to cool down the ambient temperature.

Network Tab

The Network Tab allows for configuration/monitoring of the two streaming Ethernet ports, and optional configuration of DNS servers.

Network Configuration Tab

The Network Configuration Tab is further divided into the following tabs:

- The **Interfaces** tab is used to set the individual parameters for each of the streaming Ethernet ports.
- The **DNS** tab is used to optionally configure DNS servers.

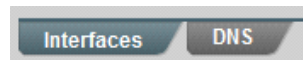

Configuration Tabs

Network Configuration Interfaces Tab

This tab allows the configuration of the individual streaming ports.

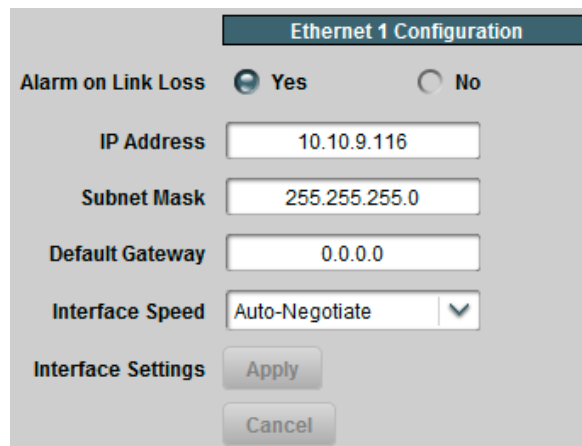
A screenshot of the 'Ethernet 1 Configuration' dialog box. It contains several configuration options: 'Alarm on Link Loss' with radio buttons for 'Yes' (selected) and 'No'; 'IP Address' with a text field containing '10.10.9.116'; 'Subnet Mask' with a text field containing '255.255.255.0'; 'Default Gateway' with a text field containing '0.0.0.0'; and 'Interface Speed' with a dropdown menu set to 'Auto-Negotiate'. At the bottom, there are 'Apply' and 'Cancel' buttons.

The following parameters can be configured:

- **Alarm on Link Loss:** If set to Yes, the unit will raise an alarm if this Ethernet interface loses link. The Card State indicator in Dashboard™ and the front Status LED will both be red. If set to No, the unit will still report loss of link in the Statistics page but no alarm will be raised. It is recommended turning on the alarm for ports that are in use; only turn it off if you do not plan to connect that port to a network.
- **IP Address:** Enter the desired IP address for this Ethernet port.
- **Subnet Mask:** Enter the desired subnet mask for this Ethernet port.
- **Default Gateway:** Enter the desired default gateway for this Ethernet port, or 0.0.0.0 if no gateway is available.
- **Interface Settings:** If you make any changes to the IP Address, Subnet Mask and/or Default Encoder fields, the **Apply** and **Cancel** buttons become active. The changes only take effect when you press the **Apply** button. Pressing the **Cancel** button reverts the

fields back to their original values. Note that the 9990-ENC-H264-IP will check the consistency of the data entered and will reject invalid combinations (i.e., combinations where the gateway is outside the interface subnet). Once the **Apply** button is pressed, a status message appears just below the **Cancel** button, as follows:

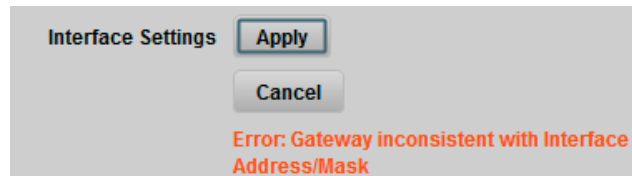
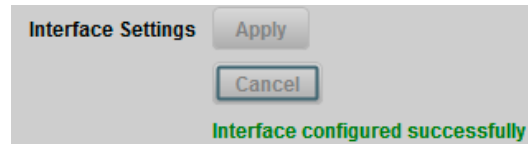

- **Interface speed:** Configures the speed of the interface. The 9990-ENC-H264-IP streaming Ethernet interfaces only support two manual modes: 100 Mb/s Full-Duplex and 1 Gb/s Full-Duplex².
 - **Auto-Negotiate:** The Ethernet port will auto-negotiate the speed.
 - **100 Mb/s Full-Duplex:** Force the port to 100Mb/s Full-Duplex mode. Note that the port will still perform auto-negotiation, but it will only advertise this mode.
 - **1Gb/s Full-Duplex:** restrict the operation to 1Gb/s Full-Duplex mode. Note that the port will still perform auto-negotiation, but it will only advertise this mode.

Notes:

- If the 9990-ENC-H264-IP streaming Ethernet interfaces are connected to a 10 Mb/s switch, hub, or network feed, link will **not** be established and the port will not recognize the connection.
- If you select **100 Mb/s Full-Duplex** or **1 Gb/s Full-Duplex** and the corresponding streaming Ethernet interface is connected to a switch, hub or network feed that does not support the selected speed, link will **not** be established and the port will not recognize the connection.
- If the interface speed is set to **Auto-Negotiate**, the streaming Ethernet port will allow link to be established in 100 Mb/s Half-Duplex mode. However, this will be flagged as a warning in the Network Statistics Interface Tab and in the Admin Event Log Tab.

Network Configuration DNS Tab

The DNS tab allows manual configuration of up to two DNS servers. They do not need to be in the same subnetwork as the streaming ports, as long as at least one default gateway is configured. DNS is only used in conjunction with the RTMP output functionality. If you are not using RTMP, there is no need to configure DNS servers.

² support for 10 Mb/s modes has been disabled, as these are unsuitable for MPEG transport over IP applications. Moreover, any modern switch supports at least 100 Mb/s Full-Duplex.

DNS Servers

DNS Server 1

DNS Server 2

DNS functionality is only used for RTMP output

DNS server configuration takes effect immediately, as soon as the information is entered. If the device has access to the Internet and your network does not have suitable DNS servers, we recommend the public Google DNS servers at 8.8.8.8 and 8.8.4.4.

Network Statistics Tab

The Network Statistics Tab is subdivided into the same tabs as the Network Configuration Tab, namely Interfaces and DNS.

Network Statistics Interface Tab

The Interface Tab reports the current IP configuration of each Ethernet port, as well as their link state and running status.

Ethernet 1 Configuration

Alarm on Link Loss

IP Address

Subnet Mask

Default Gateway

Interface Speed

Port 1 Link Link OK

Port 1 Status OK

Link Speed (Mb/s)

MAC Address **ac:83:f0:00:10:1a**

The following parameters are reported in the Network Statistics tab:

- **Alarm on Link Loss:** Reports the current setting of this parameter.
- **IP Address:** Reports the current IP Address for the port.
- **Subnet Mask:** Reports the current Subnet Mask for the port.
- **Default Gateway:** Reports the current Default Gateway for the port.
- **Interface Speed:** Reports the current setting for this parameter.
- **Port 1/2 Link:** This indicator has the following states:
 - **Link OK:** The port has established link with the network connection.

- ● **Half-Duplex Link:** The port is set to **Auto-Negotiate**, and it has achieved 100 Mb/s Half-Duplex link with the network connection. Half-Duplex links are not considered suitable for video communication. The port will operate, but we recommend that this be addressed. If Alarm on Link Loss is set to Yes, the Dashboard™ Card State will be yellow if there are no higher-priority alarms present.
- ● **No Link:** The port does not currently have link. If Alarm on Link Loss is set to Yes, the Dashboard™ Card State will be red and the Status LED in the front of the board will also be red. If Alarm on Link Loss is set to No, this indicator will still be red, but the alarm will not propagate.
- **Port 1/2 Status:** This indicator is the port overrun status. It has the following states:
 - ● **OK:** The port is operating normally.
 - ● **TX Overflow:** In the current configuration, the IP outputs are attempting to transmit more than the port capacity (i.e., the overall output data for this port exceeds the interface speed of 100 Mb/s or 1 Gb/s). The Dashboard™ Card State will be red and the Status LED in the front of the board will also be red. In this case, reduce the output bit rate (either by reducing the encoder bit rates or by removing output ports). **If this indicator is red, data is being dropped.**
- **Link Speed (Mb/s):** This parameter reports the actual speed negotiated with the switch for the port. If the port has no link, the value reported here is zero.
- **MAC Address:** This reports the MAC address of the Ethernet port.

Network Statistics DNS Tab

The Network Statistics DNS Tab reports the current DNS configuration.

DNS Servers	
DNS Server 1	192.168.43.1
DNS Server 2	0.0.0.0

DNS functionality is only used for RTMP output

Encoder 1, Encoder 2 Tabs

The Encoder 1/Encoder 2 Tabs are used to configure/monitor the individual encoder channels. The parameters in these two tabs are exactly the same.

The 9990-ENC-H264-IP can be configured with one or two encoder channels (at the time the unit is ordered, factory installed).

If an encoder channel is not installed, both its configuration and statistics windows will be empty, as shown below.

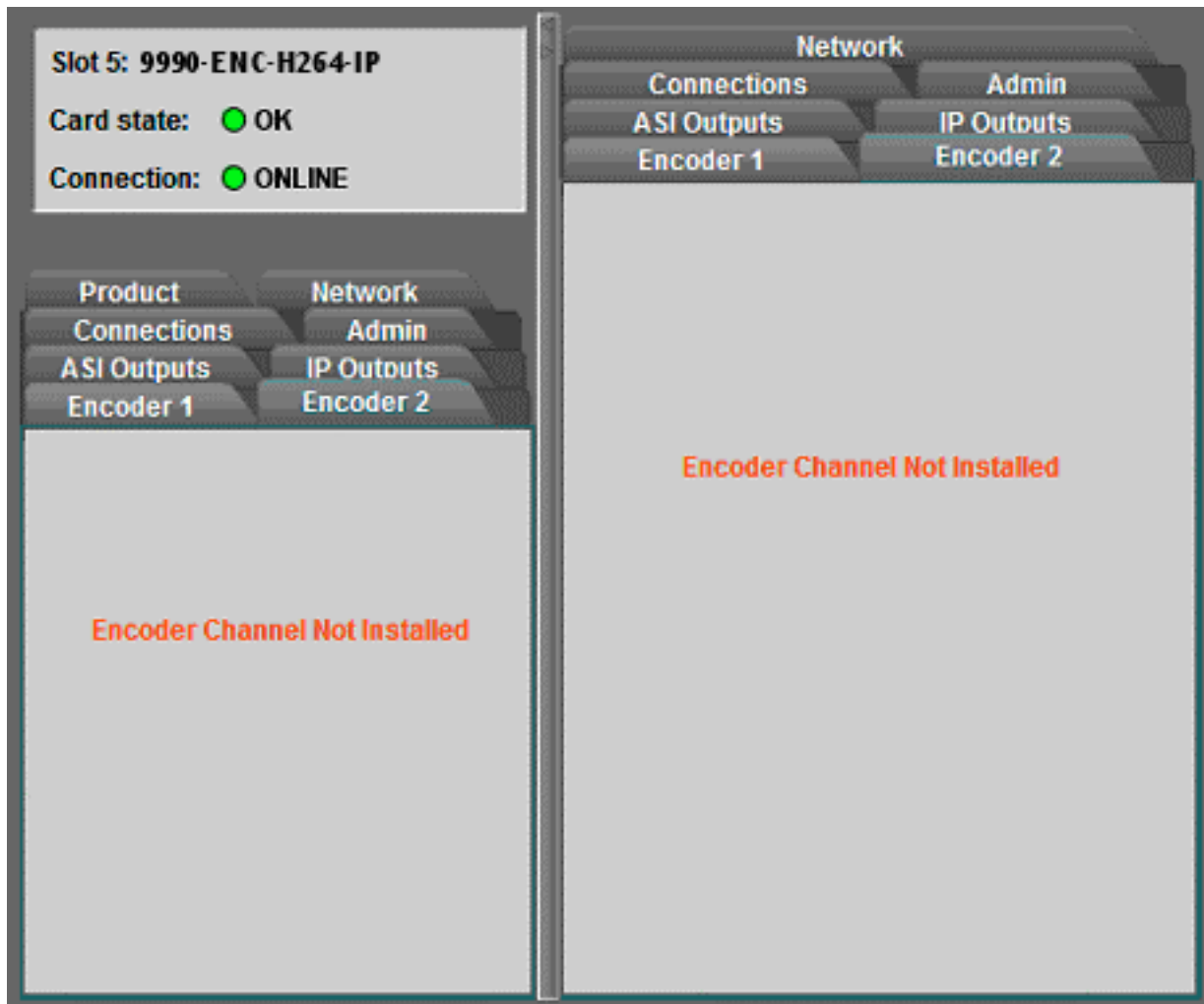

Encoder Configuration Tab

The Encoder Configuration Tab is further divided into the following tabs:

- **Basic Tab:** contains the more important configuration parameters, which all users are likely to change.

-
- **Advanced Tab:** contains the advanced configuration parameters, which do not necessarily need to be changed.
 - **Output Tab:** configures the encoder output protocol.



Configuration Tabs

In general, the encoder user interface will change as a function of the parameter selections made, to remove illegal parameter combinations.

Selections made in any of the encoder configuration screens do not take effect until the **Apply** button is pressed. If you wish to discard the changes made to the user interface, press the **Cancel** button. The **Apply/Cancel** buttons are present in all the tabs and will be grayed out until changes are made. At any given point in time, the currently running encoder configuration can be inspected in the Encoder Statistics Tab, described later in this document.

Video Input Auto-Detection

The 9990-ENC-H264-IP can be set to auto-detect the video input signal, and self-configure for the incoming resolution and frame rate. This feature allows the encoder to operate in situations where the video signal can change over time (for example, at the output of a video switch). The 9990-ENC-H264-IP is even capable of automatically recognizing whether a signal is SDI or composite, and the video standard for composite signals.

The following points should be considered when using video input auto-detection:

- The available output scaling options are limited, since some options are specific to some input resolutions.
- If the encoder is not licensed for a given configuration, it will stop encoding if the input video signal switches to a value that requires this configuration. For example, an SD encoder configured to output the same resolution as the input will stop if the input signal switches to HD.
- If the encoder is configured with auto-detection and SDI embedded audio, it will fall back to analog audio if it detects a composite video signal. If your input can switch between SDI and composite, either use analog audio for all signals, or make sure that the corresponding analog audio signal is present at the encoder unbalanced audio inputs when the video is a composite signal.

Encoder Basic Configuration Tab

The Encoder Basic Configuration Tab, shown below, is divided into three general areas:

- **General Configuration:** generic configuration parameters.
- **Video Configuration:** parameters related to video encoding.
- **Audio Configuration:** parameters related to audio encoding.

The screenshot displays the 'Encoder 1 Configuration' window, divided into three main sections:

- General Configuration:** Includes fields for 'Name' (Encoder 1), 'Encoder State' (radio buttons for Stopped and Running), and 'Input Connection' (radio buttons for Video/Audio 1 and Video/Audio 2).
- Video Parameters:** Includes 'Video Input Settings' (radio buttons for Manual Selection and Auto Detected), 'Input Resolution' (dropdown menu), 'Input Source' (dropdown menu), 'Frame/Field Rate' (radio buttons for 59.94 (NTSC), 50 (PAL), and 60), 'Output Resolution' (dropdown menu), 'Video Rate Mode' (radio buttons for CBR and VBR), 'Bit Rate Selection' (radio buttons for Video Bit Rate and Transport Bit Rate), and 'Video Bit Rate' (spin box).
- Audio Parameters:** Includes 'Sample Rate' (dropdown menu), 'Audio Source' (radio buttons for Analog Audio and SDI Embedded Audio), 'Language Code' (text field), 'Audio Encoding' (dropdown menu), 'Mode' (dropdown menu), and 'Audio Bit Rate (kb/s)' (dropdown menu).

At the bottom, there are 'Apply' and 'Cancel' buttons, with a red box around them and the label 'Apply/Cancel Configuration Changes'.

Note that the basic configuration tab may look different from what is depicted above, as the parameters may change (or appear/disappear in the GUI) based on the device's configuration and the parameter choices made.

Basic Tab – General Configuration

- **Name:** All 9990-ENC-H264-IP encoders and outputs can be assigned a user-defined name. Use any descriptive name suitable for your application, or accept the default.
- **Encoder State:** This control allows you to start/stop an encoder. This control needs to be set to **Running** for normal operation.
- **Input Connection:** This control selects which of the two rear I/O panel inputs is to be connected to this encoder. The 9990-ENC-H264-IP can run both encoders from the same

input. The default is to run Encoder 1 from Video/Audio 1 and Encoder 2 from Video/Audio 2, but all combinations are allowed. Note that the parameters presented in the Video Configuration section may change if this selection changes (for example, if you switch the encoder from a Composite input to an SDI input).

Basic Tab – Video Configuration

The 9990-ENC-H264-IP is capable of automatically identifying the video signal present in the selected input connection. The detected signal is reported in the Encoder Statistics Tab. Additionally, the encoder can also be set to auto-configure its input based on the detected signal:

- **Video Input Settings:** This parameter selects whether or not the encoder will auto-configure based on the detected video input signal.
 - **Manual Selection:** The input signal must be correctly selected using the **Input Resolution, Input Source, and Field/Frame Rate** controls for the encoder to run. If the input signal does not match the settings, the encoder will not run.
 - **Auto Detected:** The encoder will auto-detect the input signal, and automatically configure for it if it is a supported signal. The **Input Resolution, Input Source, and Field/Frame Rate** controls are not displayed.

Video Input Settings Manual Selection Auto Detected

Input Resolution: SD: 720x480i

Input Source: Composite

Frame/Field Rate: 59.94 (NTSC) 50 (PAL)

Output Resolution: Output 720x480i

Video Rate Mode: CBR VBR

Video Input Settings Manual Selection Auto Detected

Output Resolution: Same as Input

Video Rate Mode: CBR VBR

The following table lists the supported input video signals:

Composite Signals	SDI Signals
NTSC	720×480i59.94
NTSC 4.43	720×576i50
PAL B/D/G/H/I/N	1280×720p50
PAL-M	1280×720p59.94
PAL-Nc	1280×720p60
SECAM	1920×1080p23.98
	1920×1080p24
	1920×1080i50
	1920×1080i59.94
	1920×1080i60
	1920×1080p50
	1920×1080p59.94
	1920×1080p60

If **Video Input Settings** is set to **Manual Selection**, the **Input Resolution**, **Input Source** and **Field/Frame Rate** parameters are displayed and must be set to match the incoming video signal.

- **Input Resolution:** Select the resolution of the input video signal. The following four choices are available:
 - SD: 720×480i (this will be presented as 720×576i if **Field/Frame Rate** is set to **PAL**).
 - HD: 1280×720p
 - HD: 1920×1080i
 - HD: 1920×1080p
- **Input Source:** Select the input source type. This control is available only if the **Input Resolution** is set to SD. In this case, the options will be **Composite** or **SD-SDI**. If **Input Resolution** is set to any of the HD values, this control will not be selectable, and will show the appropriate type of input (HD-SDI for 1280×720p and 1920×1080i, and 3G-SDI for 1920×1080p).
- **Field/Frame Rate:** Select to match your source. For all input resolutions, the supported options always include 59.94 (for NTSC-based systems) and 50 (for PAL-based systems)³. Some resolutions have support for additional frame rates, as follows:
 - If you select the 1920×1080i or 1280×720p resolutions, this field will also include an option for a field rate of 60, used by some cameras:

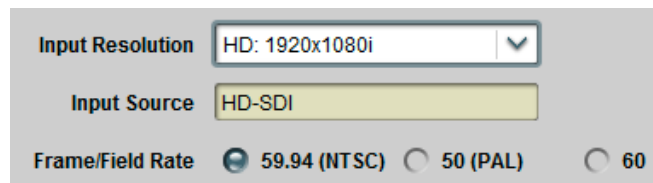

The screenshot shows a settings panel with three rows. The first row is 'Input Resolution' with a dropdown menu showing 'HD: 1920x1080i'. The second row is 'Input Source' with a dropdown menu showing 'HD-SDI'. The third row is 'Frame/Field Rate' with three radio buttons: '59.94 (NTSC)' (selected), '50 (PAL)', and '60'.

- If you select the 1920×1080p resolution, this field will also include an option for a frame rate of 23.98 (Film):

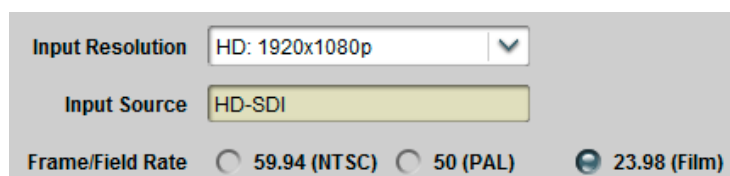

The screenshot shows a settings panel with three rows. The first row is 'Input Resolution' with a dropdown menu showing 'HD: 1920x1080p'. The second row is 'Input Source' with a dropdown menu showing 'HD-SDI'. The third row is 'Frame/Field Rate' with three radio buttons: '59.94 (NTSC)', '50 (PAL)', and '23.98 (Film)' (selected).

- **Output Resolution:** Select the desired output resolution. The values in this drop-down list are a function of the **Video Input Settings**, the **Input Resolution** and the **Frame/Field Rate**. Also, please note that some resolutions require additional licensing for the encoder. If **Video Input Settings** is set to **Manual Selection**, the following resolutions are offered:
 - Same as the input (no scaling)
 - ¾ scaling from the input

³ Support for other standard frame rates, such as 30, 60, 24, etc may be available. Please contact us if you require one of these rates.

- Low resolutions: 480×270, 320×240, and 320×180, progressive, at half and quarter frame rates (not available for 1080p inputs)
- HD inputs can be scaled (and re-interlaced if necessary) to SD resolution, anamorphic (not available for 1080p inputs)
- 720p inputs can be reduced to half frame rate (typically for Internet applications), as follows:
 - 1280×720p50 is converted to 1280×720p25
 - 1280×720p59.94 is converted to 1280×720p29.97
 - 1280×720p60 is converted to 1280×720p30
- 1080i, 720p and SD inputs can be converted to SD resolution, with progressive frame rates (ideal for computer displays), as follows:
 - 1080i59.94, 720p59.94, and 480i59.94 are converted to 720×480p29.97
 - 1080i60 and 720p60 are converted to 720×480p30
 - 1080i50 and 720p50 are converted to 720×576p25

The conversions from HD resolutions are done using anamorphic scaling.

- 1080i, 720p and SD⁴ inputs can be scaled to 640×360, with progressive frame rates, as follows:
 - 1080i59.94 and 480i59.94 are converted to 640×360p29.97
 - 720p59.94 is converted to 640×360p59.94
 - 1080i50 and 576i50 are converted to 640×360p25
 - 720p50 is converted to 640×360p50
- HD 1080i inputs can be scaled to 1280×720p at the same incoming frame rate (e.g., 1080i59.94 will be scaled to 720p29.94; 1080i50 will be scaled to 720p25)
- HD 1080i inputs can be scaled to ¼ resolution (960×540), with the same incoming frame rate
- SD inputs can be horizontally cropped to 704 pixels or horizontally scaled to 640 pixels
- SD inputs can be horizontally scaled to 640 or 528 pixels, and converted to progressive frame rates (29.97p for NTSC inputs, 25p for PAL inputs)

If **Video Input Settings** is set to **Auto Detected**, the following options are offered in this parameter:

- **Same as Input:** the encoder will produce a signal that has the same resolution and frame rate as the input (no scaling).
- **Scale 3/4 Horizontal:** the encoder will scale down the image horizontally by 3/4. The frame rate will not be changed.
- **Scale to 640×360p:** the encoder will scale the input video to 640×360. The frame rate will be the same as the input, but interlaced inputs will be de-interlaced (for example, 1920×1080i60 will yield 640×360p30). This resolution is not available for 1920×1080p inputs at any frame rates; the encoder will fall back to 3/4 horizontal scaling in this case.
- **Scale to 480×270p, Scale to 320×240p, Scale to 320×180p:** the encoder will scale the input video to the selected resolutions. Interlaced inputs will be de-interlaced as described above. Progressive inputs will be encoded at half frame

⁴ By default, SD signals have a 4:3 aspect ratio, unless they are derived from an HD source with anamorphic scaling. The 640×360 resolution is intended for 16:9 content. Scaling SD to 640×360 should only be done if the SD signal is anamorphic to start with, otherwise the resulting encoded signal will have an incorrect aspect ratio.

rate. This resolution is not available for 1920×1080p inputs at any frame rates; the encoder will fall back to 3/4 horizontal scaling in this case.

- **Video Rate Mode:** This controls whether the video elementary stream is CBR or VBR. The video bit rate setting varies according to this selection, as shown below.

The image shows two side-by-side screenshots of a control panel for Video Rate Mode. The left panel has 'Video Rate Mode' with 'CBR' selected and 'VBR' unselected. Below it, 'Bit Rate Selection' has 'Video Bit Rate' selected and 'Transport Bit Rate' unselected. A 'Video Bit Rate' input field contains the value '2000000'. The right panel has 'Video Rate Mode' with 'CBR' unselected and 'VBR' selected. Below it, 'Peak Video Rate' and 'Average Video Rate' input fields contain the values '4000000' and '2000000' respectively.

- **Bit Rate Selection:** This field is shown only if the encoder is set to **CBR** mode, and allows the user to specify either the video bit rate, or the transport bit rate. The transport bit rate includes audio, video, tables, NULL packets, and various overheads. In some situations, such as for example, RF links of fixed capacity, it is more convenient to specify the transport rate (i.e., the final bit rate “in the wire”), and let the encoder compute the corresponding video bit rate to yield the desired transport rate. In other situations, such as IPTV deployments, it is more convenient to simply specify the video bit rate and let the encoder compute the final transport rate. Note that this control is not available in the OTT protocol modes. The controls displayed vary according to this selection:

The image shows two screenshots of the Bit Rate Selection control panel. The top screenshot has 'Bit Rate Selection' with 'Video Bit Rate' selected and 'Transport Bit Rate' unselected. A 'Video Bit Rate' input field contains the value '2000000'. The bottom screenshot has 'Bit Rate Selection' with 'Video Bit Rate' unselected and 'Transport Bit Rate' selected. A 'Transport Bit Rate' input field contains the value '2000000'.

- **Video Bit Rate:** This field is shown only if the encoder is set to **CBR** mode and the Bit Rate Selection control is set to **Video Bit Rate**. It determines the video elementary stream bit rate, expressed in bits/second. Note that the bit rate resolution is 1000 bits/second.
- **Transport Bit Rate:** This field is shown only if the encoder is set to **CBR** mode and the Bit Rate Selection control is set to **Transport Bit Rate**. It determines the overall transport stream bit rate, with a resolution of 1000 bits/sec; the encoder will calculate the appropriate video bit rate the yield the desired transport rate. Please note that all transport rates are achievable; in particular, the encoder may not be able to achieve very low transport rates if the audio bit rates are high. In these cases, the actual transport rate output by the encoder will be higher than the configured value. The actual transport rate is displayed in the Encoder Statistics Tab, after the **Apply** button has been pressed. At that point, the actual encoder video bit rate can be found in the Encoder Statistics Tab, under the Basic bottom tab.
- **Peak Video Bit Rate, Average Video Bit Rate:** These two fields are shown only if the encoder is set to **VBR** mode, and determine the desired average and acceptable peak bit

rates for the video elementary stream. The peak video bit rate must be between 1.5 and 2 times the average bit rate; the user interface will enforce these limits automatically (i.e., it will update either the average or peak to be consistent with the value being entered). For both of these parameters, the resolution is 1000 bits/sec.

Basic Tab – Audio Configuration

- **Audio Source:** This parameter selects the audio source. The options are **Analog Audio**, directing the encoder will to use the analog right/left audio channels connected to the selected rear I/O panel, and **SDI Embedded Audio**, directing the encoder to extract embedded audio from the SDI input. If the video **Input Source** (see Basic Tab – Video Configuration) is set to **Composite**, this parameter is grayed out and forced to **Analog Audio**. It will be selectable only if the video input source is one of the SDI variations, or if **Video Input Settings** is set to **Auto Detected**. Please note that if the encoder is set to auto-detect the video input, and it detects a composite signal, the audio selection will fall back to analog audio regardless of the **Audio Source** settings. When **SDI Embedded Audio** is selected, additional configuration options become available, as shown below.

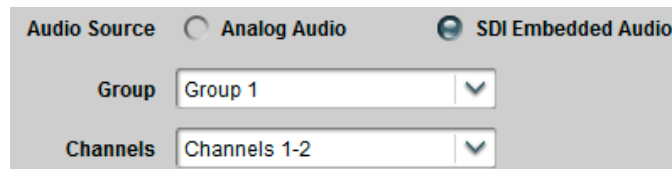

The screenshot shows the 'Audio Source' configuration panel. At the top, there are two radio buttons: 'Analog Audio' (unselected) and 'SDI Embedded Audio' (selected). Below this, there are two dropdown menus: 'Group' is set to 'Group 1' and 'Channels' is set to 'Channels 1-2'.

- **Group, Channels:** SDI embedded audio is typically divided into four groups (denoted by Group 1 to Group 4); each group has four mono channels (2 stereo pairs), denoted by Channels 1-2 and 3-4. These controls allow the selection of the desired group and channel pair. In the large majority of the cases, the first stereo pair is in Group 1, Channels 1-2, the second stereo pair is in Group 1, Channels 3-4, and so on. The **Group** selection has one additional choice, labeled **Custom DID**. This allows the encoder to use a non-standard embedded audio DID (this quite uncommon). If **Custom DID** is selected, a new configuration option becomes available, where the DID value can be entered:

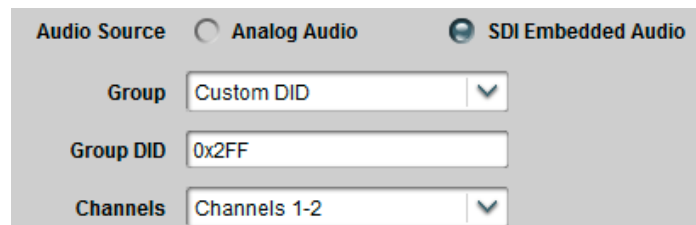

The screenshot shows the 'Audio Source' configuration panel with 'SDI Embedded Audio' selected. The 'Group' dropdown menu is set to 'Custom DID'. Below it, a text input field for 'Group DID' contains the hexadecimal value '0x2FF'. The 'Channels' dropdown menu is set to 'Channels 1-2'.

- **Group DID:** Enter the desired Group DID, in hexadecimal. Note that the entry will be immediately validated and rejected if invalid. As a reference, the table below contains the standard DIDs built into the system for Groups 1 to 4.

Group	SD-SDI DID	HD-SDI DID
Group 1	0x2FF	0x2E7
Group 2	0x1FD	0x1E6
Group 3	0x1FB	0x1E5
Group 4	0x2F9	0x2E4

- **Language Code:** This parameter represents the 3-letter ISO 639-2 language code for the audio, to be placed in the audio language descriptor in the PMT. For a complete list of the language codes, see this URL:

http://www.loc.gov/standards/iso639-2/php/code_list.php

If the Output Protocol in the Encoder Output Tab is set to RTMP, this field will not be displayed as RTMP does not use the transport stream container.

- **Audio Encoding:** This parameter selects the audio encoding algorithm. The available choices depend on the **Audio Source** selection. For **Analog Audio**, the choices are **MPEG-1 Layer II** and **AAC-LC**. For **SDI Embedded Audio**, the **Dolby Passthrough** option is offered in addition to the previous choices. Note that AAC-LC requires additional licensing. The two variants for this control are depicted below.

If the Output Protocol in the Encoder Output Tab is set to RTMP, this field is forced to AAC-LC and becomes not editable. The reason is that the RTMP protocol has no support for MPEG-1 Layer II audio at 48 kHz sampling. It also has no support for Dolby.

- **Mode:** The available choices for this parameter depend on the **Audio Encoding** selection, as follows:
 - **MPEG-1 Layer II:** the available modes are **Stereo** or **Single Channel**. If you select **Single Channel** (Mono), only the audio connected to the Left input will be encoded.
 - **AAC-LC:** the available modes are **Stereo**, **Mono**, or **Dual Mono**. If you select **Mono**, only the audio connected to the Left input will be encoded.
 - **Dolby Passthrough:** This parameter is not displayed.

- **Audio Bit Rate:** The format of this parameter is a function of the **Audio Encoding** setting. For MPEG-1 Layer II, this parameter is a drop-down list of valid discrete bit rates; the values in the list are also a function of the **Mode** Setting. For AAC-LC, the range is 112 to 512 kb/s for Stereo and Dual Mono, and 56 to 256 kb/s for Mono. This parameter is not displayed for Dolby Passthrough as the 9990-ENC-H264-IP will automatically detect the incoming audio bit rate.
- **Peak Audio Bit Rate:** This parameter is only displayed for AAC-LC. It must be set at least 1 kb/s higher than the **Audio Bit Rate**. The maximum value is 288 kb/s for Mono, and 576 kb/s for Stereo and Dual Mono.

The image shows a configuration panel with four rows of controls:

- Audio Encoding:** A dropdown menu currently set to "AAC-LC".
- Mode:** A dropdown menu currently set to "Stereo".
- Audio Bit Rate (kb/s):** A numeric input field with a value of "128" and up/down arrow buttons.
- Peak Audio Rate (kb/s):** A numeric input field with a value of "129" and up/down arrow buttons.

- **Sample Rate:** This field is for information purposes only. The 9990-ENC-H264-IP only supports 48 kHz audio sample rate.

Encoder Advanced Configuration Tab

The appearance of the Encoder Advanced Configuration Tab is a function of the choices made on the Encoder Basic Configuration Tab. The Advanced Configuration Tab is divided into four major areas:

- **Video Parameters:** these are advanced controls related to the encoding of the video.
- **VBI/Ancillary Data Insertion:** controls related to Closed-Captioning and Active Format Description (AFD) insertion.
- **Audio Parameters:** these are advanced controls related to the audio subsystem.
- **Mux Parameters:** these are advanced controls related to audio/video multiplexing and (P)SI tables.

Advanced Tab – Video Parameters

The Video Parameters section is shown below:

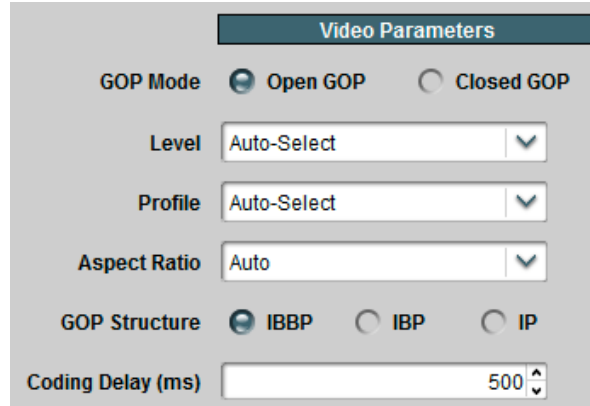

- **GOP Mode:** Select between **Open GOP** and **Closed GOP**. The normal setting is Open GOP. Closed GOP is used for some storage applications, and is also required by some CDNs (such as YouTube); there is a very small negative impact in video quality if Closed GOP is selected. For some output protocols (HLS and RTMP), this control becomes read-only and is forced to Closed GOP.
- **Level:** Selects the H.264 level signaled in the bitstream. The default setting is **Auto-Select**, whereby the encoder will signal the minimum required level based on the current settings. If, for some reason, a different (higher) level is desired, it can be selected here. Note that the encoder will not honor a level selection that is lower than the legal minimum for the current settings. It is typically not necessary to change the level from Auto-Select.
- **Profile:** This control has four options:
 - **Auto-Select:** With this setting, the encoder will use High Profile for HD and Main Profile for SD.
 - **High Profile:** With this setting, the encoder will always use High Profile for all resolutions.
 - **Main Profile:** With this setting, the encoder will always use Main Profile for all resolutions.
 - **Baseline Profile:** With this setting, the encoder will always use Baseline Profile. The **GOP Structure** control will not be selectable in Baseline Profile and will be set to IP.

Note that, as the profile is lowered, there will be video quality degradation. In other words, for a given resolution and bit rate, the video quality for High Profile will be better than Main Profile, and Main Profile will be better than Baseline Profile. Whether the quality difference is noticeable will depend on the resolution, bit rate, and specific video content.

- **Aspect Ratio:** The H.264 bitstream includes aspect ratio information in the VUI Parameters part of the Sequence Parameter Set. Normally, the encoder will automatically set the correct aspect ratio code. However, in some situations, it may be necessary to override this (for example, when scaling HD to SD). Use this control to override the default aspect ratio set by the encoder. In particular, if the video input is 1920x1080i, and the content is being scaled to SD, use either **16:11 (PAL Widescreen)** or **40:33 (NTSC Widescreen)** to get the correct aspect ratio.

- **GOP Structure:** Select between **IBBP**, **IBP** and **IP**. Selecting **IBBP** gives the best video quality, but some low-end decoders require **IP**. If **Profile** is set to Baseline Profile, this control will not be selectable and will be forced to **IP**.
- **Coding Delay:** This parameter controls the size of the H.264 Coded Picture Buffer (CPB), expressed in milliseconds. This is one component of the end-to-end encoder/decoder delay. The unit latency is 150 milliseconds plus the value of this control. For example, if the Coding Delay is set at its default of 500 milliseconds, the latency will be 650 milliseconds. Note that the overall encoder/decoder latency is also a function of the latencies in the decoder. **Please note that reducing the coding delay will reduce latency at the expense of video quality!** Use VBR if at all possible when reducing the latency, and set the peak rate as high as you can afford. For example, if the encoder output is 1920×1080i, a bit rate on the order of 10 to 12 Mb/s (either CBR average or VBR peak) is required to produce a stream without artifacts with a Coding Delay of 100 milliseconds.

Note that if the **Output Resolution** setting in the Basic Tab – Video Configuration is set to one of the low resolutions (480×270, 320×240, or 320×180), the **Profile** and **GOP Structure** controls will not be selectable; this section will appear as follows:

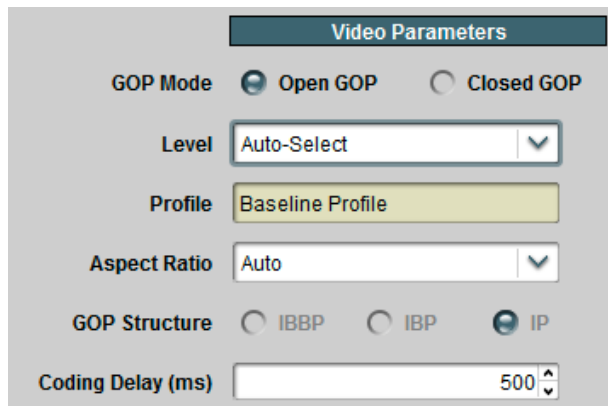

Also note that if the **Input Resolution** setting in the Basic Tab – Video Configuration is set to 1920×1080p, the **Profile** and **GOP Structure** controls will not be selectable; this section will appear as follows:

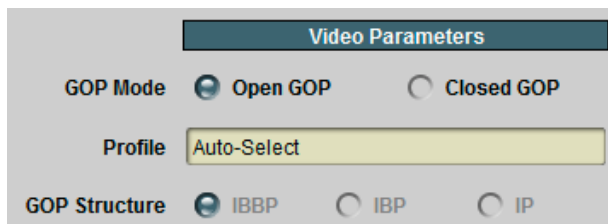

Advanced Tab – VBI/Ancillary Data Insertion

The 9990-ENC-H264-IP can extract the following data types from the video input and insert them in the compressed video output:

-
- Closed Captioning
 - Active Format Description (AFD)

Closed Captioning

The Closed Captioning controls are only displayed in the following situations:

- In the Basic Tab – Video Configuration, **Video Input Settings** is set to **Manual Selection**, and **Frame/Field Rate** is set to **59.94 (NTSC)**.
- In the Basic Tab – Video Configuration, **Video Input Settings** is set to **Auto Detected**.

The appearance of this control is also a function of the **Video Input Settings**, **Input Resolution** and **Input Source** parameters, as depicted below.

The Closed Captioning controls are as follows:

- **Enable CC:** check this box to enable Closed-Captioning insertion. Closed Captions are inserted in the video elementary stream, as per ATSC A/72. Both CEA-608 and CEA-708 captions are supported.
- **CC Source:** this controls where the encoder extracts closed captions from. As depicted below, this field may or may not be editable, depending on the video input settings, input resolution and input source. The options are:
 - **CEA-608 Line 21:** this option can only be used for SD inputs. The encoder will extract all the CEA-608 information from both fields of Line 21, if present.
 - **SMPTE-334 VANC:** this option can only be used for SDI inputs. The encoder will expect closed-captioning information in the VANC. Both CEA-608 and CEA-708 modes are supported (and automatically detected).

Note that if **Video Input Settings** is set to **Auto Detected**, the encoder will comply with the **CC Source** if possible, but may fall back to another setting depending on the input signal. For example, if **CC Source** is set to **CEA-608 Line 21** and the encoder detects an HD signal, it will fall back to **SMPTE-334 VANC**. Conversely, if it is set to **SMPTE-334 VANC** and it detects a composite signal, it will fall back to **CEA-608 Line 21** if that composite signal is NTSC, or turn off CC if that composite signal is PAL.

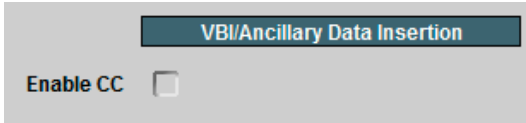

Closed-Captioning Disabled

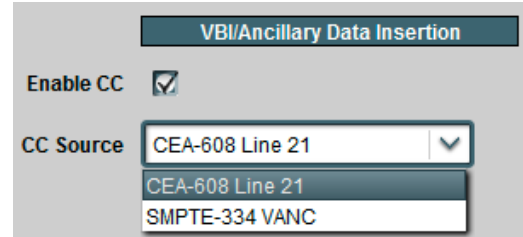

**Input Source: SD-SDI
Input Resolution: SD**

or

Video Input Settings: Auto Detected

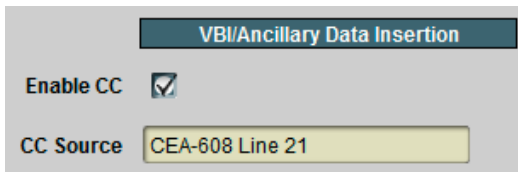

**Input Source: Composite
Input Resolution: SD**

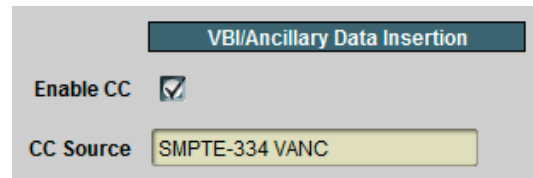

**Input Source: HD-SDI or 3G-SDI
Input Resolution: HD**

Active Format Description

The 9990-ENC-H264-IP can extract Active Format Description (AFD) information from the incoming video signal and insert it in the compressed bitstream. AFD information can be extracted from the following sources:

- For SDI signals, AFD information can be present in the VANC as per SMPTE-2016-3. This is the primary way of conveying AFD information on a professional video feed.
- For SD signals (either from Composite or SD-SDI sources), AFD information can be synthesized from Wide Screen Signaling (WSS) data present in the VBI (line 20 for NTSC signals, line 23 for PAL signals).
- The 9990-ENC-H264-IP also has the option of inserting a user-defined AFD code (instead of receiving it from the video input).

The AFD controls are as follows:

- **Enable AFD:** Check this box to enable AFD extraction and insertion. This control is always available. AFD is inserted in the video elementary stream as per ATSC A/72 and ETSI TS 101 154.
- **AFD Source:** This controls where the AFD information is coming from. The options are:
 - **Line 20 WSS/Line 23 WSS:** This option causes the encoder to synthesize AFD information from WSS. It is available only if the input resolution is SD or if the video input settings are auto-detected. It will be displayed as Line 20 for NTSC and Line 23 for PAL. For PAL inputs, the conversion follows ETSI TS 101 154 Appendix B.4.

- **SMPTE-2016-3 VANC:** This option causes the encoder to extract AFD from the VANC. It is only available for SDI inputs or if the video input settings are auto-detected.
- **Manual AFD Selection:** This option allows the user to specify a fixed AFD code to be inserted. Any AFD information received from the input is ignored. This can be used to override the original AFD information, or when the video is being scaled (e.g., when the input is HD and is being converted to SD).
- **AFD Code:** This control is displayed only when AFD Source is set to Manual AFD Selection. It corresponds to the codes listed in SMPTE-2016-1, Table 1.



Note that if **Video Input Settings** is set to **Auto Detected**, the encoder will comply with the **AFD Source** if possible, but may fall back to another setting depending on the input signal. For example, if **AFD Source** is set to **Line 20/23 WSS** and the encoder detects an HD signal, it will fall back to **SMPTE-2016-3 VANC**. Conversely, if it is set to **SMPTE-2016-3 VANC** and it detects a composite signal, it will fall back to **Line 20/23 WSS** (and automatically use the correct line number based on the input signal). **Manual AFD Selection** is always honored.

Advanced Tab – Audio Parameters

The Audio Parameters are divided into three subgroups, some of which vary (and may not be present) according to the selections made in the various audio configuration sections in the Encoder Basic Configuration Tab and the installed rear I/O panel. A sample of the Audio Parameters section is depicted below.

The screenshot shows the 'Audio Parameters' window with the following controls:

- Analog Audio Parameters:** A red-bordered box containing:
 - Balanced Audio Level: Radio buttons for SMPTE (selected) and EBU.
 - Audio Gain L (dB): Text input field with value 0.0.
 - Audio Gain R (dB): Text input field with value 0.0.
 - Audio Mute L: Checkmark input field.
 - Audio Mute R: Checkmark input field.
- AV Sync Adjustment:** A red-bordered box containing:
 - Audio Delay (ms): Spin box with value 0.
- PMT Information:** A red-bordered box containing:
 - Audio Type: Dropdown menu with value Undefined.
- Audio Encoder Specific Configuration:** A red-bordered box containing:
 - CRC: Radio buttons for CRC Off (selected) and CRC On.
 - Original/Copy: Radio buttons for Copy (selected) and Original.
 - Copyright: Radio buttons for Not Protected (selected) and Protected.
 - Emphasis: Dropdown menu with value None.

Analog Audio Parameters

These parameters are only displayed if **Audio Source** in Basic Tab – Audio Configuration is set to **Analog Audio**. The parameters are:

- **Balanced Audio Level:** This control is only displayed if the encoder is equipped with a balanced audio rear I/O panel. It selects the nominal signal level, as follows:
 - **SMPTE:** Nominal level according to SMPTE RP155, typically used in North America.
 - **EBU:** Nominal level according to EBU R68, typically used in Europe. The EBU level is 6 dB higher than the SMPTE level.
- **Audio Gain L (dB), Audio Gain R (dB):** These controls allow an independent gain adjustment for the left/right audio channels, from -18.0 dB to +18.0 dB, in steps of 0.5 dB.
- **Audio Mute L, Audio Mute R:** These controls allow muting of the left/right audio channels.

A/V Sync Adjustment

This parameter can be used to provide a small amount of A/V sync adjustment, for cases where the A/V sync in the input signal to the encoder is not correct. If, in the input signal, audio is **behind** the video, you can use this parameter to compensate for up to 100 milliseconds. Note that it is only available for MPEG-1 Layer II and AAC-LC encoding; it will not be displayed for Dolby Passthrough.

- **Audio Delay (ms):** Use this to compensate for up to 100 milliseconds of audio delay in the input signal. This setting will advance the audio in relation to the video by the amount configured.

PMT Information

The PMT Information section has the following parameters:

- **Audio Type:** determines the audio type in the PMT audio descriptor. This setting has no actual impact on how the audio is encoded; it only affects its description in the PMT. The choices are:
 - **Undefined:** no further information. This is the most common setting.
 - **Clean Effects:** indicates that the audio has no language.
 - **Hearing Impaired:** indicates that the audio is prepared for the hearing impaired.
 - **Visual Impaired Commentary:** indicates that the audio is prepared for the visually impaired viewer.

If the **Audio Encoding** setting in the Basic Tab – Audio Configuration is set to **Dolby Passthrough**, another parameter becomes available in the PMT Information section:

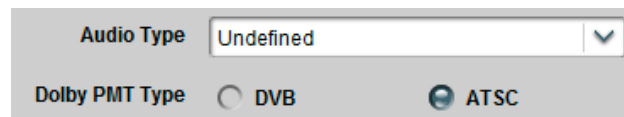

- **Dolby PMT Type:** this parameter controls how Dolby AC-3 audio is signaled in the PMT. The two choices are:
 - **DVB:** Dolby Audio is signaled as per ETSI TS 101 154 Appendix C (stream_type 0x06 with the AC-3 Descriptor from EN 300 468 annex D).
 - **ATSC:** Dolby Audio is signaled as per ATSC A/53 Part 3 (stream_type 0x81). However, the 9990-ENC-H264-IP is currently unable to generate the ATSC AC-3 Descriptor; please contact Product Support if this is an issue in your network.

If the Output Protocol in the Encoder Output Tab is set to RTMP, the PMT Information fields will not be displayed as RTMP does not use the Transport Stream container.

Audio Encoder Specific Configuration

The appearance of this control depends on the **Audio Encoding** setting in the Basic Tab – Audio Configuration.

MPEG-1 Layer II Configuration

AAC-LC Configuration

The parameters are:

- **CRC:** Enables/Disables CRC insertion in the audio elementary stream. This is normally left disabled (CRC off).
- **Original/Copy:** Controls the state of the Original/Copy flag in the audio elementary stream. This setting does not affect the actual audio encoding.
- **Copyright:** Controls the state of the Copyright flag in the audio elementary stream. This setting does not affect the actual audio encoding.
- **Emphasis:** Controls the state of the Emphasis flags in the audio elementary stream. This setting does not affect the actual audio encoding. The available values are **None**, **50/15 us**, and **ITU-T J.17**.

Advanced Tab – Mux Parameters

These parameters control the details of the audio/video multiplexing, and the (P)SI tables. If the Output Protocol in the Encoder Output Tab is set to RTMP, these parameters will not be shown as RTMP does not use the Transport Stream container.

The following Mux Parameters are always available if the Output Protocol is not set to RTMP:

- **PMT PID, PCR PID, Video PID, Audio PID:** These parameters control the Packet Identifier (PID) values for the PMT, PCR, Video and Audio. The values can be entered in hexadecimal (prefixed by 0x) or in decimal. Valid values are from 0x20 (32) to 0x1FFE (8190). PMT PID, Video PID and Audio PID must be distinct values. PCR PID can either be the same as the video PID or distinct from the other values as well. The

user interface will not accept an invalid entry at any time – it will immediately revert to the previous value.

- **Program Number:** Enter the desired program number for this encoder channel. Valid program numbers go from 1 to 65535 and are always entered in decimal.
- **Transport Stream ID:** Enter the desired Transport Stream ID for this encoder channel. Values in this field can be entered both in hexadecimal (prefixed by 0x) or in decimal.
- **Generate SDT:** This box is always shown but is not selectable for the HTTP Live Streaming and RTMP protocols. If this box is checked, an SDT will be generated for this encoder channel. Additional SDT parameters become available once this box is checked, as depicted below.

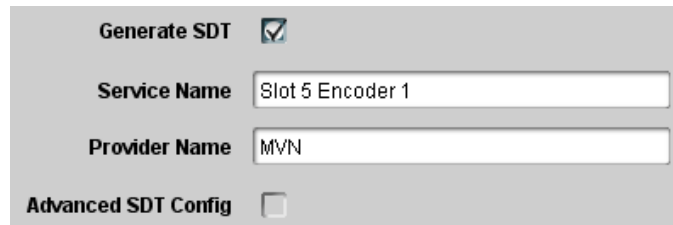

The screenshot shows a configuration panel with the following elements:

- Generate SDT:** A checkbox that is checked.
- Service Name:** A text input field containing "Slot 5 Encoder 1".
- Provider Name:** A text input field containing "MVN".
- Advanced SDT Config:** A checkbox that is unchecked.

- **Service Name:** Enter the desired SDT service name for this encoder channel. The default name is **Slot X Encoder Y**, where **X** is the openGear® slot number where the 9990-ENC-H264-IP is installed, and **Y** is 1 or 2 (for Encoder 1 or Encoder 2).
- **Provider Name:** Enter the desired SDT service provider name. The default is **MVN**.
- **Advanced SDT Config:** By default, the other SDT values are automatically set by the system. If you need to configure them, check this box, and a new set of parameters appears, as shown below.

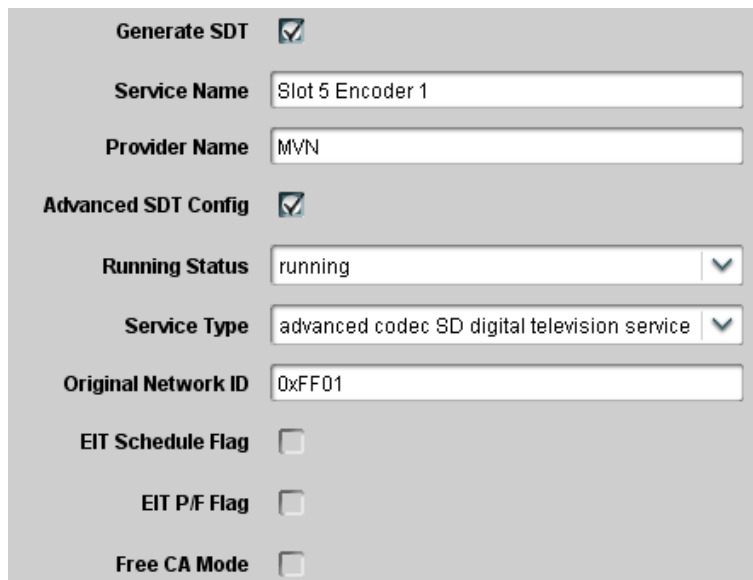

The screenshot shows the configuration panel with the following elements:

- Generate SDT:** A checked checkbox.
- Service Name:** "Slot 5 Encoder 1".
- Provider Name:** "MVN".
- Advanced SDT Config:** A checked checkbox.
- Running Status:** A dropdown menu set to "running".
- Service Type:** A dropdown menu set to "advanced codec SD digital television service".
- Original Network ID:** "0xFF01".
- EIT Schedule Flag:** An unchecked checkbox.
- EIT P/F Flag:** An unchecked checkbox.
- Free CA Mode:** An unchecked checkbox.

- **Running Status:** Indicates the status of the service. The options are **undefined**, **not running**, **starting**, **pausing**, **running**, and **service off-air**. The value used for this parameter when **Advanced SDT Config** is not enabled is running.

- **Service Type:** Indicates the type of service. The value used for this parameter when **Advanced SDT Config** is not enabled is advanced codec SD digital television service if the encoder is in SD mode, or advanced codec HD digital television service if the encoder is in HD mode. The drop-down list offers a few of the most common choices. If you need to code something other than these choices, select **custom setting** in the drop-down list and a new parameter will become available, as show below.

- **Custom Service Type:** Enter the service type. This field accepts both hexadecimal (prefixed by 0x) and decimal values. The valid range is from 0 (0x00) to 255 (0xFF).
- **Original Network ID:** This field contains the Network ID code from which this program originated. This field accepts both hexadecimal (prefixed by 0x) and decimal values. Valid values are from 0 (0x0000) to 65535 (0xFFFF). The default value for this field is 0xFF01, which is in the range of values allocated for video over IP. The complete set of registered Network IDs can be downloaded from this URL:

http://www.dvbservices.com/identifiers/export/original_network_id

- **EIT Schedule Flag:** Check this box to set the flag. This flag indicates that EIT schedule information is present for this service. Since the 9990-ENC-H264-IP does not generate EITs, the correct setting of this flag is not set. Only set it if you intend to mux an EIT downstream of the 9990-ENC-H264-IP.
- **EIT P/F Flag:** Check this box to set the EIT present/following flag for this service. Since the 9990-ENC-H264-IP does not generate EITs, the correct setting of this flag is not set. Only set it if you intend to mux an EIT downstream of the 9990-ENC-H264-IP.
- **Free CA Mode:** Check this box to set the Free CA Mode flag. If this flag is set, it indicates that one or more components of the service are scrambled. Since the 9990-ENC-H264-IP does not offer scrambling, the correct setting of this flag is not set. Only set it if you intend to scramble the program downstream from the 9990-ENC-H264-IP.

Encoder Output Tab

The Encoder Output Tab is used to configure the network protocol used to transmit the encoded video.

The options are:

- **UDP/IP Streaming:** the output of the encoder will be transmitted over UDP/IP, unicast or multicast. This option is typically used for IPTV or corporate applications. The encoder output can be replicated on both Ethernet streaming ports.
- **HTTP Live Streaming:** the output of the encoder is directed to a web server (which can be the internal server in the encoder or an external server), which in turn serves it to web clients using HTTP Live Streaming. If this option is selected, the encoder output is not available to ASI and IP Output ports, and the video bit rate is limited to 15 Mb/s. Moreover, the **GOP Mode** parameter in the Advanced Tab – Video Parameters will be forced to **Closed GOP**.
- **Direct HTTP Streaming:** the output of the encoder is available to clients over a standard HTTP connection. Clients will open an HTTP connection to the encoder, send a standard HTTP GET request, and receive the bitstream (for as long as they keep the connection open).
- **RTMP:** the encoder will operate as an RTMP client, connect to a specified RTMP server and publish the stream, similar to the Adobe Flash® Live Media Encoder (FMLE). If this is selected, the **GOP Mode** parameter in the Advanced Tab – Video Parameters will be forced to **Closed GOP**.

Once an option is selected, the appropriate configuration parameters are displayed.

UDP/IP Streaming

When UDP/IP Streaming is selected, the following configuration parameters are displayed:

UDP stream optimized for consumer (IPTV) devices

Ethernet 1 Output Configuration

Enabled

Ethernet 2 Output Configuration

Enabled

The UDP streams from the device are optimized for playback on consumer (IPTV) devices. In order to save network bandwidth, these streams do not include NULL packets, and may not be playable in professional IRDs. If compatibility with professional IRDs is desired, the Cobalt 9223 professional encoder should be used instead.

The encoder output can be transmitted using either one of the two streaming Ethernet ports, or on both simultaneously. In order to transmit on a given Ethernet port, check the corresponding **Enabled** box. Once the box is checked, the following configuration parameters become available:

The screenshot shows a configuration window titled "Ethernet 1 Output Configuration". It contains the following fields and checkboxes:

- Enabled:** A checked checkbox.
- UDP Port:** A text box containing the value "2001".
- Destination Address:** A text box containing the value "225.1.1.1".
- TTL:** A text box containing the value "128".
- TOS:** A text box containing the value "0".
- Set DF Bit:** A checked checkbox.

The configuration parameters are as follows:

- **UDP Port:** selects the UDP port to transmit to. Valid values are between 1 and 65535. Note that, in traditional IP networks, UDP ports between 1 and 1023 are reserved for administrative uses. It is recommended to use UDP ports 1024 and higher. The 9990-ENC-H264-IP, however, will accept any legal value.
- **Destination Address:** selects the IP address to transmit to. Any valid unicast or multicast address can be entered here, with the exception of the loopback range (127.0.0.0 to 127.255.255.255). The 9990-ENC-H264-IP will also accept the broadcast IP address of 255.255.255.255, and will transmit the packets as Ethernet broadcasts. Use of broadcasts, however, is strongly discouraged.
- **TOS:** This parameter allows the configuration of the Type-Of-Service (TOS) byte in the IP header (also known as the Differentiated Services – DS – field). Valid values are between 0 and 255. Configuring this is only useful if the downstream router is configured to honor the field.
- **TTL:** This parameter allows the configuration of the Time-To-Live (TTL) byte in the IP header. Valid values are between 1 and 255. If not explicitly configured, it defaults to 128. This field controls how many hops the packet can traverse before it is dropped by a router. The default value of 128 is suitable for virtually all applications.
- **DF Bit:** This parameter allows the configuration of the Do-not-Fragment (DF) bit in the IP header. The 9990-ENC-H264-IP will never produce fragmented packets, and with the UDP payload set to 7 transport packets, the IP packets are guaranteed to fit inside the Ethernet MTU. This control is provided for compatibility with legacy switches/routers. Some legacy equipment may exhibit performance problems if this bit is not set. This is not an issue with current network equipment.

HTTP Live Streaming

HTTP Live Streaming is a protocol designed to deliver live streaming content to clients on the Internet using a standard unmodified Web Server and the standard HTTP protocol.

The highlights of the protocol are:

- The encoder segments the bitstream into small files of similar duration, at some suitable points.
- The encoder continuously uploads the files as they are created to a standard web server.
- Every time the encoder uploads a new file, it also updates a special playlist file in the server, which informs the clients of which segments are available.
- The encoder also takes care of deleting old files from the server.
- The clients can connect to the web server at will; they download the playlist file, and start playing the segments as they come.
- A standard unmodified web server can be used.

A typical use case is depicted below.

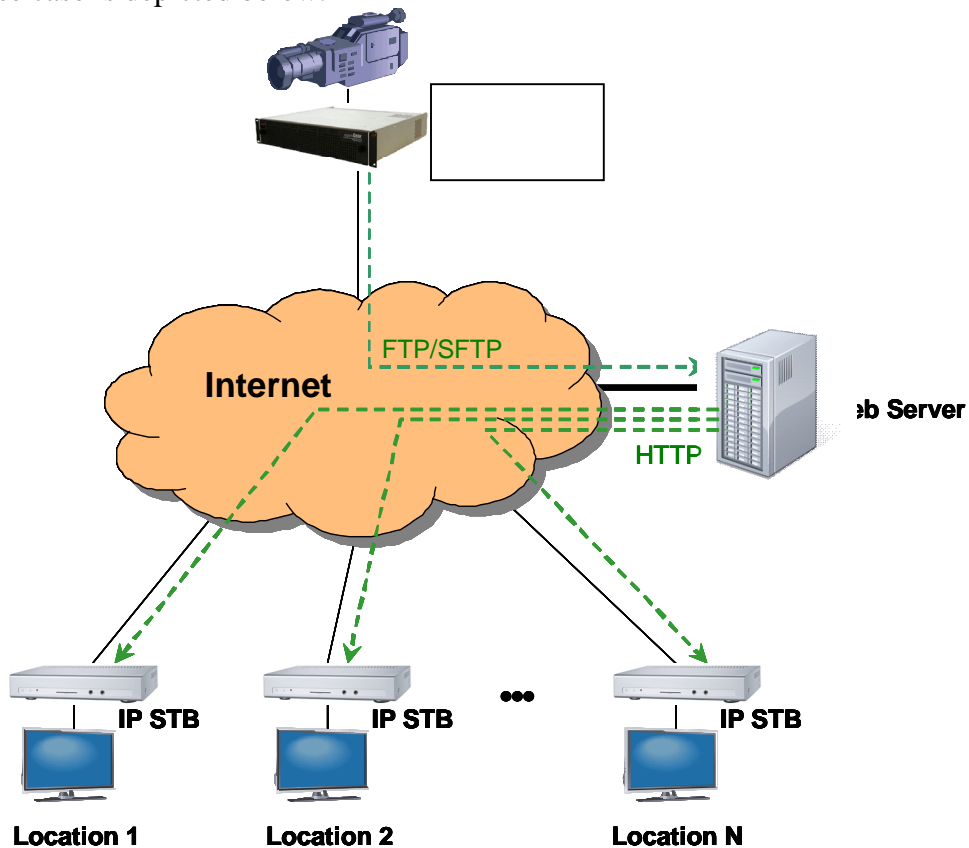

HTTP Live Streaming is supported in the 9990-ENC-H264-IP. The content can be uploaded to an external server, or served directly from the unit.

When uploading to an external server, the configurable parameters are:

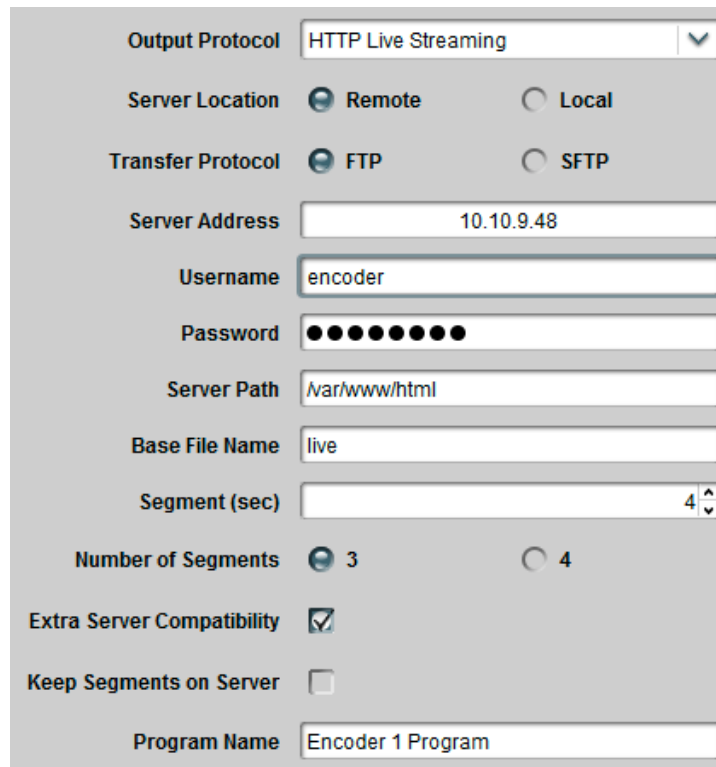

The screenshot shows a configuration window with the following fields and values:

- Output Protocol: HTTP Live Streaming
- Server Location: Remote, Local
- Transfer Protocol: FTP, SFTP
- Server Address: 10.10.9.48
- Username: encoder
- Password: [masked]
- Server Path: /var/www/html
- Base File Name: live
- Segment (sec): 4
- Number of Segments: 3, 4
- Extra Server Compatibility:
- Keep Segments on Server:
- Program Name: Encoder 1 Program

- **Server Location:** Select **Remote** to have the segments uploaded to a remote web server, using FTP or SFTP; select **Local** to use the local server in the device itself.
- **Transfer Protocol:** This configures the protocol to be used between the 9990-ENC-H264-IP and the web server for uploading the files. The two options are **FTP** and **SFTP** (Secure FTP). FTP exchanges data and password in the clear, while SFTP encrypts both flows.
- **Server Address:** Enter the IP address of the web server here. It needs to be reachable from either one of the 9990-ENC-H264-IP's Ethernet ports.
- **Username:** Enter the username to be used when uploading the files to the server.
- **Password:** Enter the password corresponding to the user name, to be used when uploading the files.
- **Server Path:** Enter the absolute server path for the directory where the files should be placed. It is recommended that a separate directory be created for each encoder.
- **Base File Name:** Enter the base file name for the files created in the server. The encoder will create the following files:
 - **basename.m3u8:** This is the top playlist file. For the example above, where the base file name is **live**, the playlist file will be **live.m3u8**. This file will contain a single bit rate profile. It is created when the encoder starts, and not changed during operation. For backward compatibility with previous versions, a top playlist with a **.m3u** extension and identical contents will also be created.
 - **basename_p.m3u8:** This is the current playlist file for the encoder profile. It is updated every time a new segment is created.

- **basename_XXXX.ts:** These will be the bitstream encoded files. XXXX is an increasing count. For the example above, the encoder will create files named **live_1.ts, live_2.ts, live_3.ts, live_4.ts**, and so on. At any given point in time, there will be five or six consecutive files in the configured directory if the encoder is configured to remove older files.
- **Segment (sec):** Number of seconds per segment. This defines the approximate size (in seconds) for the above bitstream encoded files. The valid range is from 1 to 20 seconds. Note that the clients will experience latency approximately equal to the segment size times the number of segments. The recommended value is 10 seconds. Setting the segment size to less than 3 seconds may cause performance issues with the FTP/SFTP server (especially Windows servers running FileZilla); the result will be a non-zero count of dropped segments.
- **Number of Segments:** This defines the number of bitstream segments advertised in the playlist. The minimum number, as per the HLS specification, is 3. Some set-top boxes require 4 segments. Apple devices (iPads, iPods, etc.) work well with 3 segments.
- **Extra Server Compatibility:** Check this box if the encoder has problems renaming files in the server. This is typically required for Windows FTP servers. Linux-based servers do not need this. It is recommended checking this box only if your server requires it.
- **Keep Segments on Server:** Normally, when a segment falls out of the playlist file, it is automatically deleted by the encoder. If you check this box, the bitstream is left in the server. Clients will still start playing from the first segment in the playlist.
- **Program Name:** This program name is placed in the playlist file. Whether or not it is shown depends on the client. This is an optional parameter.

Using the settings above, if the directory **/var/www/TV** is published on server **www.example.com** as **http://www.example.com/TV**, the URL for the video will be:

http://www.example.com/TV/live.m3u8

When using the built-in server in the 9990-ENC-H264-IP, the options are:

The screenshot shows a configuration window with the following settings:

- Output Protocol:** HTTP Live Streaming (dropdown menu)
- Server Location:** Local (radio button selected, Remote is unselected)
- Segment (sec):** 4 (spin box)
- Number of Segments:** 3 (radio button selected, 4 is unselected)
- Program Name:** Encoder 1 Program (text input field)

- **Server Location:** Select **Local** to use the local server in the device itself.
- **Segment (sec):** Number of seconds per segment. This defines the approximate size (in seconds) for the above bitstream encoded files. The valid range is from 1 to 20 seconds. Note that the clients will experience latency approximately equal to the segment size times the number of segments. Given the limited amount of memory storage in the local

encoder server, at higher bit rates the segment size will be limited. The 9990-ENC-H264-IP has 20 Mbytes of storage per encoder.

- **Number of Segments:** This defines the number of bitstream segments advertised in the playlist. The minimum number, as per the HLS specification, is 3. Some set-top boxes require 4 segments. Apple devices (iPads, iPods, etc.) work well with 3 segments.
- **Program Name:** This program name is placed in the playlist file. Whether or not it is shown depends on the client. This is an optional parameter. If entered, it will be shown as part of the encoder link in the web page generated by the 9990-ENC-H264-IP.

In local server mode, the access URLs for the content are:

```
http://xxx.xxx.xxx.xxx/HLS/encoder1.m3u8  
http://xxx.xxx.xxx.xxx/HLS/encoder2.m3u8
```

where **xxx.xxx.xxx.xxx** is the IP Address of the 9990-ENC-H264-IP Ethernet port. In the 9990-ENC-H264-IP openGear® version, HLS streams are available through both streaming Ethernet ports. Also note that if you use a browser to go to the encoder IP address (i.e., just go to <http://xxx.xxx.xxx.xxx>), there will be a link for the HLS page.

HLS Implementation Notes

- When HTTP Live Streaming is selected, the **GOP Mode** control is set to **Closed GOP** and is not selectable. This is done to ensure that each segment is self-contained.
- The maximum video bit rate allowed in HLS mode is 15 Mb/s.
- The maximum aggregate performance of the built-in HLS server in the 9990-ENC-H264-IP is between **20 and 30 Mb/s** (total bit rate to all clients), and is somewhat dependent on network conditions. The built-in server is intended to serve only a small handful of clients and performance is **not guaranteed** at the capacity limits; if you need to scale, please use a remote server.
- If you are streaming to Apple devices such as iPhones, iPads or iPods, you must also select the following:
 - **Audio Encoding:** Select **AAC-LC**.
 - **Output Resolution:** If you are streaming to older Apple devices, select one of the resolutions ending in **/15p** (e.g., 320x240/15p). If your input is PAL, these resolutions will be shown ending in **/12.5p**. Newer devices may be able to support higher resolutions.

Direct HTTP Streaming

Direct HTTP Streaming is an output mode whereby clients open a standard HTTP connection to the 9990-ENC-H264-IP and issue a standard HTTP GET request. The 9990-ENC-H264-IP will send the appropriate HTTP response followed by the encoder bitstream; the bitstream will be transmitted for as long as the client maintains the connection. Since HTTP runs on top of the

TCP protocol, it is possible for the 9990-ENC-H264-IP to deliver content over the Internet using this mode. However, it has the following limitations:

- The 9990-ENC-H264-IP has to send one independent copy of the bitstream to each client. There is a limit of 5 clients or 20 Mb/s per Ethernet port in this mode.
- The TCP protocol is capable of flow control; if the client is not fast enough, or if the network between the 9990-ENC-H264-IP and the client is not fast enough, the protocol will attempt to throttle the encoder, which is not possible. The 9990-ENC-H264-IP will buffer a small amount of bitstream in this case, but if the overall performance of the client/network link combination is insufficient to support the configured encoder data rate, the 9990-ENC-H264-IP will drop transport packets.

Direct HTTP Streaming has one single parameter:

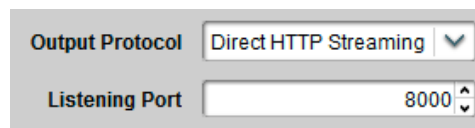

The image shows a configuration window with two input fields. The first field is labeled 'Output Protocol' and has a dropdown menu with 'Direct HTTP Streaming' selected. The second field is labeled 'Listening Port' and has a text input with '8000' and a small up/down arrow icon on the right side.

- **Listening Port:** Use this to select the TCP port to be used by the 9990-ENC-H264-IP to listen to HTTP connections. Please note that the 9990-ENC-H264-IP will not accept the values 22, 23, 80⁵, 1935 and 5253 for this parameter as these ports may be internally used by the 9990-ENC-H264-IP. The listening ports for Encoders 1 and 2 can be set independently (and can be set to the same value if desired).

The URL for accessing the bitstream will be:

http://encoder_ip:port/encoder1 (access to encoder1)

or

http://encoder_ip:port/encoder2 (access to encoder2)

Where **encoder_ip** is the IP address of either one of the 9990-ENC-H264-IP Ethernet ports (configured in the Network Tab) and **port** is the Listening Port configured above. For example, if one of the IP addresses of the 9990-ENC-H264-IP is set to 10.10.9.80, and the Listening Port is set to 8000 (as shown above), the URL for Encoder 1 will be:

<http://10.10.9.80:8000/encoder1>

Please note that none of the common web browsers (Explorer, Firefox, etc) are capable of directly playing this URL; what these browsers will do is download the bitstream to a file. If you wish to see video playback on a web page, please review the “Playing Video on a Web Page” section later in this document.

⁵ The 9990-ENC-H264-IP has an internal Web Server running on port 80.

RTMP

The 9990-ENC-H264-IP can operate as an RTMP client, and publish a real-time, live bitstream to an RTMP server. RTMP clients (such as the Adobe® Flash® Player) can connect to the server and play the live stream. The 9990-ENC-H264-IP can generally connect to the same servers as the Adobe Flash Live Media Encoder (FMLE).

An RTMP server publishing point is defined by the following:

- An RTMP URL, of the form:

rtmp[t][e][s]://servername/app

- A stream name

The first part of the URL defines the protocol, as follows:

- **rtmp**: standard RTMP with no security
- **rtmpt**: RTMP tunneled over HTTP
- **rtmpe**: encrypted RTMP using proprietary security
- **rtmps**: encrypted RTMP over SSL
- **rtmpte**: encrypted RTMP using proprietary security, tunneled over HTTP
- **rtmpts**: encrypted RTMP over SSL, tunneled over HTTP

The **servername** field is the host name or IP address of the RTMP server to be contacted. The **app** field is the application in the server that should receive the data being transmitted. Note that, depending on the service, the **app** field may contain a complete path or even a set of parameters.

The encoder can be configured with primary/backup RTMP servers. If it cannot connect to the primary server, it will automatically try the backup.

The RTMP configurable parameters are:

The screenshot displays a configuration interface for RTMP settings, organized into several sections:

- Output Protocol:** A dropdown menu set to "RTMP".
- RTMP Protocol:** A dropdown menu set to "rtmp".
- Primary Server Section:**
 - Primary Server:** A text input field containing "server.domain.com".
 - Primary Network Interface:** Radio buttons for "Any" (selected), "Ethernet 1", and "Ethernet 2".
 - Primary App:** A text input field containing "app/parameters".
 - Primary Server URL:** A text input field displaying "rtmp://server.domain.com/app/parameters".
 - Primary Stream:** A text input field containing "livestream".
- Backup Server Section:**
 - Backup Server:** A text input field containing "backup.domain.com".
 - Backup Network Interface:** Radio buttons for "Any" (selected), "Ethernet 1", and "Ethernet 2".
 - Backup App:** A text input field containing "backup_app/backup_parameters".
 - Backup Server URL:** A text input field displaying "rtmp://backup.domain.com/backup_app/backup_parameters".
 - Backup Stream:** A text input field containing "backup_livestream".
- Common Parameters Section:**
 - Redundancy Switch Time (sec):** A numeric input field set to "10".
 - Port Selection:** Radio buttons for "Use Default" (selected) and "Specific Port".
 - Authentication:** Radio buttons for "Yes" and "No" (selected).
 - Connect:** Radio buttons for "Yes" (selected) and "No".

- **RTMP Protocol:** Select the protocol variant, as discussed above.
- **Primary Server:** Enter the host name or IP address of the primary (or single) RTMP server to be contacted. If you want to use host names instead of IP addresses, make sure to configure at least one DNS server. DNS servers may be configured in the Network Configuration DNS Tab.
- **Primary Network Interface:** Select the network interface to be used when contacting the primary server. The settings are:
 - **Any:** use the “best” network interface to connect to the server.
 - **Ethernet 1:** preferably use Ethernet 1 to connect to the server. If the server is not in the same subnet as Ethernet 1, and no default gateway is set for Ethernet 1, this setting will be ignored.
 - **Ethernet 2:** preferably use Ethernet 2 to connect to the server. If the server is not in the same subnet as Ethernet 2, and no default gateway is set for Ethernet 2, this setting will be ignored.
- **Primary App:** Enter the application name in the primary server, as discussed above. Consult your CDN or server documentation to find out what should be entered in this field.
- **Primary Server URL:** This informational field is automatically updated as you configure the RTMP parameters. It displays the full RTMP URL for the primary server.
- **Primary Stream:** Enter the stream name for the primary server. Consult your server documentation or CDN to find out what should be entered here. Some servers allow arbitrary stream names, while others use this field for authentication and thus require specific names.

- **Backup Server:** If you have a backup RTMP server, configure it here; otherwise, this field can be left empty. The encoder will only attempt to contact the backup RTMP server if it cannot establish a connection with the primary server.
- **Backup Network Interface:** Select the network interface to be used when contacting the backup server. The meaning of the choices is the same as the **Primary Network Interface** described above.
- **Backup App:** Enter the application name in the backup server. If this field is left blank, the value entered for **Primary App** is used.
- **Backup Server URL:** This informational field is automatically updated as you configure the RTMP parameters. It displays the full RTMP URL for the backup server.
- **Backup Stream:** Enter the stream name for the backup server. If this field is left blank, the value entered for **Primary Stream** is used.
- **Redundancy Switch Time (sec):** This field is only displayed if a **Backup Server** is specified (i.e., it will not be present if **Backup Server** is left blank). It sets the timeout for encoder to switch servers after the RTMP connection is established, if the server stops accepting data (i.e., when the **IP Output Rate** goes to zero).
- **Port Selection:** If your RTMP server is using the default TCP ports for the protocol variant, select **Use Default**. If your server is using a non-standard port, select **Specific Port**. When **Specific Port** is selected, an additional field is displayed:

Common Parameters

Port Selection Use Default Specific Port

Port

Authentication Yes No

- **Port:** This field is only displayed if **Port Selection** is set to **Specific Port**. Configure a non-standard TCP port here.
- **Authentication:** Some RTMP servers require username/password authentication for access. If your server does not require authentication, select **No**, otherwise select **Yes**. If you select **Yes**, additional fields are presented:

Port Selection Use Default Specific Port

Authentication Yes No

Username

Password

Connect Yes No

- **Username:** Enter the username to be used for authentication.
- **Password:** Enter the password to be used for authentication.
- **Connect:** This parameter controls whether or not the encoder should actually establish a connection with the server. If you set this parameter to **No**, the encoder will run but no

data will be transmitted. This is useful to pre-configure a session, and turn it on later when it comes the time to broadcast.

Notes:

- The maximum aggregate RTMP performance for the 9990-ENC-H264-IP is **12 Mb/s**. If the unit has two encoder channels, this limit applies to the sum of their video bit rates. For example, if one encoder channel is configured for RTMP at 8 Mb/s, the other can only be configured for RTMP at 4 Mb/s or less. The limit does not apply to encoder channels configured for UDP/RTP/ASI streaming.
- Using one of the encrypted variants of the protocol (**rtmpe**, **rtmps**, **rtmpte**, or **rtmpts**) will also have a performance impact and will reduce the maximum usable rate.
- Performing a firmware update while the encoder is running RTMP at high bit rates may cause service interruptions to the RTMP stream. If you need to update the firmware, we recommend that you do so during a maintenance window.
- Some CDNs (such as YouTube, for example) only accept frame rates up to 30 fps and prefer progressive content. The device can convert any input signal to progressive at a lower bit rate (see the Basic Tab – Video Configuration section).
- In RTMP Mode, the device will force Closed GOP operation (see the Advanced Tab – Video Parameters section) as required by some CDNs.

The Apply/Cancel Buttons

The **Apply/Cancel** buttons are available at the bottom of the **Basic**, **Advanced**, and **Connection** screens. These are not separate buttons – they are multiple instances of the same buttons, repeated on each screen for convenience. If no changes have been made to the settings, the **Apply/Cancel** buttons are grayed out; once any changes are made, they become available. Changes do not take effect until the **Apply** button is pressed. If you make changes but decide not to apply them, click on the **Cancel** button and the user interface reverts to where it was before. Once you click on the **Apply** button, the changes are implemented.



In general, most changes will cause the encoder channel to stop and start again, causing a brief (2-second) interruption to the stream. Changes to the following parameters are implemented on-the-fly, without stopping the encoder:

- Audio Source in Basic Tab – Audio Configuration
- Language Code in Basic Tab – Audio Configuration
- Any CC/AFD configurations made in Advanced Tab – VBI/Ancillary Data Insertion
- Audio Gain L/R in Analog Audio Parameters
- Audio Mute L/R in Analog Audio Parameters
- Audio Type and Dolby PMT Type in PMT Information

Encoder Statistics Tab

The Encoder Statistics Tab is divided into four lower tabs, as indicated below:



The **Basic**, **Advanced** and **Output** tabs are direct equivalents of their configuration counterparts. They present the current value of each of the configuration parameters. When the **Apply/Cancel** buttons are grayed out, the contents of these tabs exactly match their configuration counterparts. When the **Apply/Cancel** buttons are active, configuration parameters may have been changed. The current (running) encoder configuration can still be inspected in the statistics tabs, prior to clicking on the **Apply** button.

The **Status** Tab provides a summary of the current status of the encoder. It is divided into two areas, the **Encoder Status** area and the **Output Status** area. The Encoder Status area reflects the current status of the encoding subsystem, and the Output Status area reflects the status of the network output subsystem. Both areas change depending on the individual subsystem settings.

Encoder Status	
Encoder 1 Status	<input checked="" type="radio"/> OK
Encoder 1 Video Status	<input checked="" type="radio"/> Locked
Video Detected	Composite: NTSC
Transport Rate	2,652,000

Output Status	
Eth1 Out Status	<input checked="" type="radio"/> OK
Eth2 Out Status	<input type="radio"/> Disabled

Encoder Status

The variables displayed in the Encoder Status area vary according to the encoder configuration, but the following four basic parameters are always displayed:

- **Encoder 1/2 Status:** This gives the overall encoder status. Its values are:
 - **OK:** The encoder is running normally.
 - **Stopped:** The encoder has been manually stopped (see **Encoder State** in Basic Tab – General Configuration).
 - **Error:** The encoder should be running but it is not. This status will be briefly shown when the encoder is starting. The possible causes for this are:
 - The encoder has no input (check **Encoder 1/2 Video Status**)
 - There is a mismatch between the video input signal and the encoder configuration. For example, the input is 1080i and the encoder is configured for 720p.

- **Encoder 1/2 Video Status:** This indicates whether or not the selected video input front-end is locked. This status is also reflected in the rear I/O panel LED next to the video input. The possible values are:
 - **Locked:** The selected video input front-end is locked.
 - **Unlocked:** The selected video input front-end is unlocked.
- **Video Detected:** If there is any recognizable video signal at the encoder video input, this field will indicate what type of signal the encoder is detecting. This detection is independent of the video input settings and is intended to aid the operator in making the correct selection. If a video signal is detected, the text in this field will either start with the word **Composite** (if an analog composite video signal is detected), or **SDI** (if a digital SDI signal is detected). If no recognizable video signal is detected, this field will indicate **No signal**. For the detected video signals, the encoder will provide further information on the type of signal, as follows:
 - For **Composite** signals, the encoder will further report the encoding system, as follows:
 - Systems with 59.94 fields/sec: **NTSC, NTSC 4.43, PAL-M**
 - Systems with 50 fields/sec: **PAL B/D/G/H/I/N, PAL-Nc, SECAM**
 - For **SDI** signals, the encoder will indicate additional information, as follows:
 - For Standard Definition and High Definition signals, this field will report resolution, frame/field rate, and whether the signal is progressive or interlaced. Examples:
 - **SDI: 1920x1080i59.94**
 - **SDI: 1280x720p50**
 - For High Definition signals whose resolution is not 1920x1080 or 1280x720, the encoder will report the input as **SDI: unknown**. Encoding of such signals is not supported by the device.
- **Transport Rate:** This indicates the overall transport rate, including NULL packets (which are not actually transmitted), coming out of the encoder subsystem. The actual rate will be lower than this by about 5%.

If Closed Captions are enabled, the encoder reports whether or not it is receiving them:

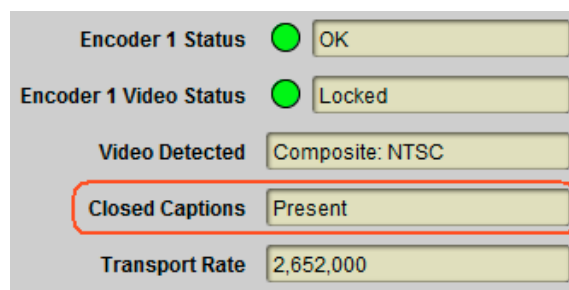

- **Closed Captions:** This reports Closed Caption insertion. This field will report **Present** or **Not Present**. If Closed Captions are reported as **Not Present**, the possible reasons are:
 - If the caption source is EIA-608 Line 21, it means that the encoder cannot find a valid closed caption waveform on that line.

- If the caption source is SMPTE-334 VANC, it means that the encoder is either not receiving closed caption messages, or it is receiving EIA-708 messages without a caption field.

Note that it is possible for the encoder to be receiving closed caption data that is empty (without actual captions). These will be reported as **Present**.

If AFD insertion is enabled, the encoder reports whether or not it is receiving them, and what AFD code is being inserted:

The screenshot shows a control panel with the following fields:

- Encoder 1 Status: OK
- Encoder 1 Video Status: Locked
- Video Detected: Composite: NTSC
- Closed Captions: Present
- AFD: Code 1000 (highlighted with a red box)
- Transport Rate: 2,652,000

- **AFD:** This reports AFD insertion. This field will report either **Not Present** (if no AFD is being received) or **Code XXXX**, if AFD is being received; XXXX is the current AFD code being inserted. If AFD Source is set to Manual AFD Selection, this field will report the selected manual code.

If the input is SDI, the encoder reports the detected type of SDI signal:

The screenshot shows a control panel with the following fields:

- Encoder 1 Status: OK
- Encoder 1 Video Status: Locked
- Video Detected: SDI: 1920x1080i59.94
- SDI Standard: HD SDI (highlighted with a red box)
- Transport Rate: 6,942,000

- **SDI Standard:** this indicator reports the detected SDI signal. Possible values are **unlocked**, **SD SDI**, **HD SDI** and **3G SDI**. This is useful to resolve SDI signal mismatch issues (for example, when the input signal is SD SDI and the encoder is configured for HD).

If the input is SDI and the **Audio Source** parameter in Basic Tab – Audio Configuration is set to **SDI Embedded Audio**, two more indicators are shown:

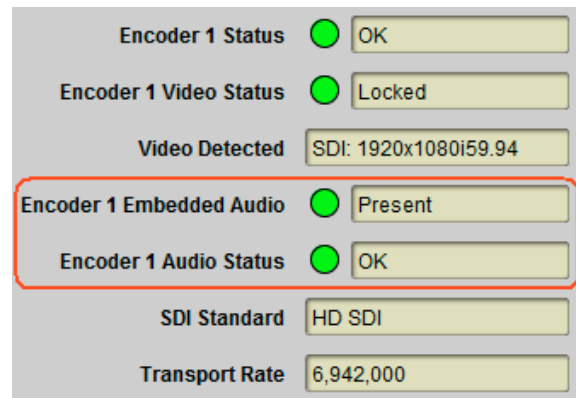

- **Encoder 1/2 Embedded Audio:** This indicator flags whether or not embedded audio is actually present on the selected Group/Channel combination (see Basic Tab – Audio Configuration). The following values are presented:
 - **Present:** Embedded audio is present in the selected Group/Combination.
 - **Not Present:** The SDI input has no lock, it is not possible to determine whether embedded audio is present or not.
 - **Not Present:** Embedded audio is not present in the selected Group/Channel combination. Check the source settings, or select a different Group/Channel combination.
- **Encoder 1/2 Audio Status:** This indicator flags any errors in the embedded audio and will have the following values:
 - **OK:** No errors detected.
 - **Not Present:** Embedded audio is not present – errors cannot be detected. This status will be issued when there is no SDI lock, or when there is no embedded audio.
 - **Error:** Embedded audio errors are being detected. If this indicator is red, audio is corrupted or glitching. The possible causes for this are:
 - Corrupted embedded audio in the input – checksum errors
 - Audio sampling rate mismatch
 - The channel is configured for Dolby Passthrough, and the data present in the selected Group/Channel is not Dolby AC-3

If Dolby Passthrough is configured, one additional indicator is shown:

Encoder 1 Status	<input checked="" type="radio"/>	OK
Encoder 1 Video Status	<input checked="" type="radio"/>	Locked
Video Detected		SDI: 1920x1080i59.94
Encoder 1 Embedded Audio	<input checked="" type="radio"/>	Present
Encoder 1 Audio Status	<input checked="" type="radio"/>	OK
Encoder 1 Passthrough		Dolby AC-3, 448 kb/s
SDI Standard		HD SDI
Transport Rate		7,173,000

- **Encoder 1/2 Passthrough:** This indicator contains the status of the Dolby AC-3 Passthrough function. It may contain the following values:
 - **Dolby AC-3, xxx kb/s:** this means that the data in the selected group/pair has been correctly identified as Dolby AC-3; its bit rate is reported here.
 - **Unknown Format:** this means that data is present in the selected group/pair, but it is not Dolby AC-3.
 - **Not Present:** this means that there is no data in the selected group/pair.

Output Status

The parameters shown in the Output Status area depend on the **Output Protocol** selection in the Encoder Output Tab.

If **UDP/IP Streaming** is selected, the following indicators are shown:

IP Output Rate		3,438,000
Eth1 Out Status	<input checked="" type="radio"/>	OK
Eth2 Out Status	<input type="radio"/>	Disabled

- **IP Output Rate:** this indicator reports the approximate payload bit rate on each of the enabled Ethernet outputs.
- **Eth1/2 Out Status:** this field will indicate the following conditions:
 - **OK:** The UDP Output is operating normally (either streaming or ready to stream).
 - **No Response:** The UDP Output is configured for unicast operation, but it does not have a destination MAC address. The Dashboard™ Card State and the Status LED will be red.
 - **No Response:** The UDP Output is configured for unicast operation, and the destination stopped responding to ARP. The IP Output is using an old cached MAC

-
- address. The Dashboard™ Card State will be yellow (but packets are being transmitted).
- **Disabled:** The UDP Output has been disabled (by unchecking the **Enabled** box in the UDP/IP Streaming section of the Encoder Output Tab).

If **HTTP Live Streaming** is selected, the following indicators are shown:

IP Output Rate	2,367,937
Segments Transferred	15
HTTP Dropped Segments	0
HTTP Transfer Errors	0

- **IP Output Rate:** this indicator reports the average transfer rate into the server, in bits/second, averaged over the last segment.
- **Segments Transferred:** this indicator reports the number of bitstream segments successfully transferred so far.
- **HTTP Dropped Segments:** this indicator reports the number of segments dropped. A segment will be dropped if the previous segment has not been completely transferred when it becomes ready. A non-zero count here indicates that there is a performance problem between the encoder and the server – either in the network (not enough bandwidth) or in the server (not enough CPU power/disk bandwidth). If the segment size is small (3 seconds or less), increasing the segment size may improve the situation.
- **HTTP Transfer Errors:** this indicator reports the number of errors encountered while transferring segments. These may be network errors, or may be configuration errors. The exact error description will be shown in the configuration area, in the area on top of the **Apply** button. One example is shown below, where the server is not responding (incorrect IP address).

Output Protocol	Select Protocol ▼
HTTP Streamer: couldn't connect to host	
Apply	
Cancel	

If **Direct HTTP Streaming** is selected in the Encoder Output Tab, the following indicators are shown:

IP Output Rate	4,857,984
Connections	2
Dropped Packets	0

- **IP Output Rate:** This indicator reports the aggregate average bit rate to all connected clients (so it can be higher than the transport rate).
- **Connections:** This indicator reports the number of clients currently connected to this encoder.
- **Dropped Packets:** This indicator reports the number of transport packets dropped over the current connections. Once a connection terminates, the dropped packet count for that connection is reset.

If **RTMP** is selected in the Encoder Output Tab, the following indicators are shown:

IP Output Rate	1,131,544
Encoder 1 RTMP Status	● Connected
Server Connection	Primary
Video Buffer %	0
Audio Buffer %	0
Dropped Packets	0

- **IP Output Rate:** this field reports the average bit rate transferred to the server. It will be lower than the transport rate due to the lower container overhead used by RTMP. It is possible for the IP Output Rate to be less than the intrinsic bit rate of the encoder for short periods of time, depending on server and network conditions. The encoder will buffer the bitstream and attempt to “catch up” in these cases. If it cannot, audio/video bitstream data may be dropped.
- **Encoder RTMP Status:** This indicator reports the state of the RTMP connection to the server. The possible states are:
 - ● **Connected:** The encoder has established a connection with the RTMP server and is transferring data.
 - ● **Waiting for Encoder:** The encoder is not attempting to connect to the RTMP server. The reasons are:
 - The encoding core is not running (i.e., the encoder is not generating bitstream). This can be because the encoder is explicitly stopped (**Encoder State** set to **Stopped** in Basic Tab – General Configuration) or it has no valid input.

-
- The RTMP output is configured not to connect to the server (**Connect** set to **No** in the RTMP configuration section).
 - ● **Not Connected:** The encoder is running, but it is unable to connect to the RTMP server. Possible reasons are:
 - The encoder cannot contact the server.
 - The RTMP parameters are incorrect.
 - The server was specified as a host name, and the encoder cannot convert that to an IP address (i.e., no DNS, or server name misspelled).

Check the Admin Event Log Tab for more details.

- **Server Connection:** RTMP can be optionally configured with a primary and a backup server. If the primary server cannot be contacted, the encoder will attempt to connect to the backup server. This field indicates which server (**Primary** or **Backup**) the encoder is currently connected or attempting to connect.
- **Video Buffer %, Audio Buffer %:** The encoder has separate buffers for audio and video. These buffers are used to temporarily store the bitstream if there is not enough network and/or server bandwidth. However, if this situation persists, the buffers start to fill up. These indicators report the current state of the buffers. If they overflow, data is dropped. Ideally, these buffers should stay empty (close to 0%).
- **Dropped Packets:** If the buffers overflow, data is dropped. The encoder will drop entire access units (an audio block or a video frame). This indicator has a count of the number of access units dropped for the current connection. This count resets when a new connection is established.

Admin Tab

The Admin tab contains a number of general administrative functions, each on its own tab. The general layout is shown below:

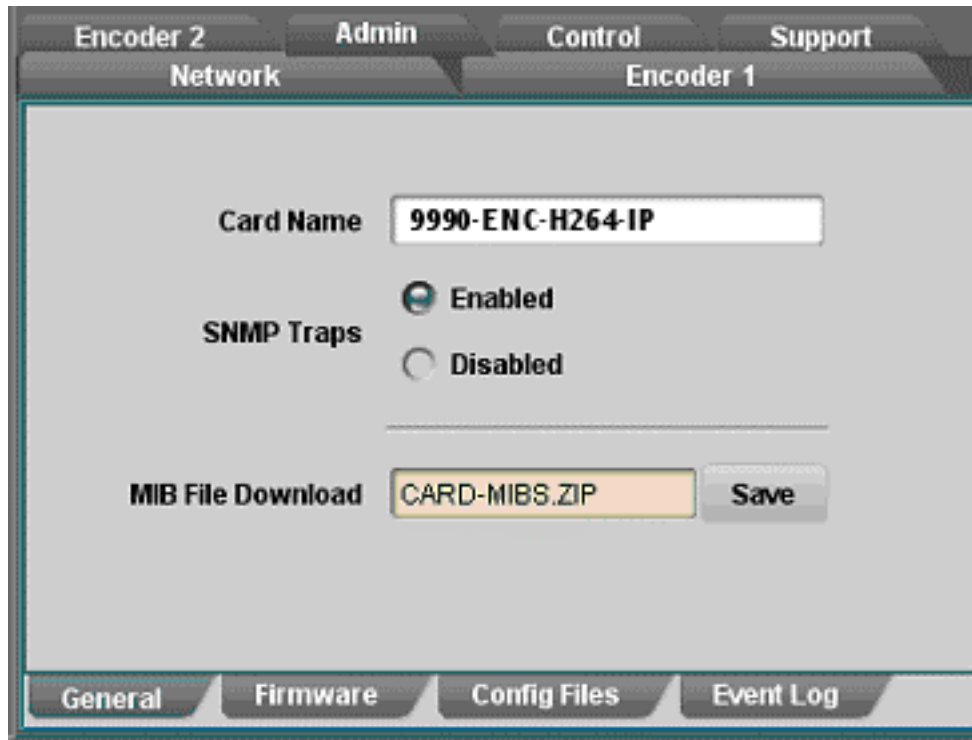

The Admin tabs are:

- **General:** Manages a number of general device parameters; provides an SNMP MIB download.
- **Firmware:** Manages firmware images.
- **Config Files:** The 9990-ENC-H264-IP has the ability to store multiple configurations, and it has a number of pre-set configurations as well. These are managed in this tab.
- **Event Log:** The 9990-ENC-H264-IP contains a non-volatile event log. It can be inspected and downloaded from this tab.

The Admin Statistics tabs are simplified read-only versions of the corresponding Admin Configuration tabs. They will not be explicitly described here.

Admin General Tab

The Admin General Tab includes the following parameters:

- **Card Name:** This field defaults to “9990-ENC-H264-IP” but can be set to any descriptive name. The name provided here will also appear in the Dashboard™ Tree View.
- **SNMP Traps:** This allows SNMP traps to be enabled or disabled⁶. Note that this setting does not take effect immediately – it will become active the next time the unit is rebooted.
- **MIB File Download:** The 9990-ENC-H264-IP provides an up-to-date copy of its MIBs. If you click on the **Save** button, a zip file with the relevant MIBs will be downloaded to your computer. This zip file contains the device MIBs, as well as the Ross Video and openGear® MIBs required to compile the device MIBs.

The Admin General Tab is depicted below:

The screenshot shows a configuration panel with the following elements:

- Card Name:** A text input field containing "9990-ENC-H264-IP".
- SNMP Traps:** Two radio buttons, with "Enabled" selected and "Disabled" unselected.
- MIB File Download:** A text input field containing "CARD-MIBS.ZIP" and a "Save" button to its right.

Admin Firmware Tab

The 9990-ENC-H264-IP can hold up to three distinct firmware images: a **Factory** image, and two upgrade images, called **Image 1** and **Image 2**. The Factory image can never be overwritten, and will always be available as a fall-back in case of problems or failed updates. Image 1 and Image 2 can be updated at will. Since the unit offers two upgrade images, it is always possible to fall back to the previous image if there are any problems with the current one. The unit will also automatically fall back to the factory image if it detects a corrupted firmware image. Finally, the push buttons on the front of the unit allow for a forced override to the factory image, as described in the Front Switches section.

9990-ENC-H264-IP firmware is updated in the same fashion as with any standard openGear® unit. Once you obtained the upgrade image from Cobalt, place it anywhere in your computer and click on the **Upload** button, as shown below. A dialog box allows you to select the upgrade file. Note that you can simultaneously upgrade all of your 9990-ENC-H264-IP units over multiple chassis if you wish. For more detail, consult the **Dashboard User Manual**, chapter 6, section **Upgrading Device Software**. The Dashboard manual can be downloaded from:

<http://www.opengear.tv/dashboard-software/>

⁶ SNMP is an optional feature in the openGear™ frame controller. The 9990-ENC-H264-IP SNMP functions are only available if SNMP is licensed in the frame controller.

Note that uploading firmware to the 9990-ENC-H264-IP does not affect its operation in any way and does not introduce any glitches in the inputs/outputs, except when running RTMP at high bit rate. If you are running RTMP at high bit rate, uploading firmware to the 9990-ENC-H264-IP may cause momentary stream interruptions.

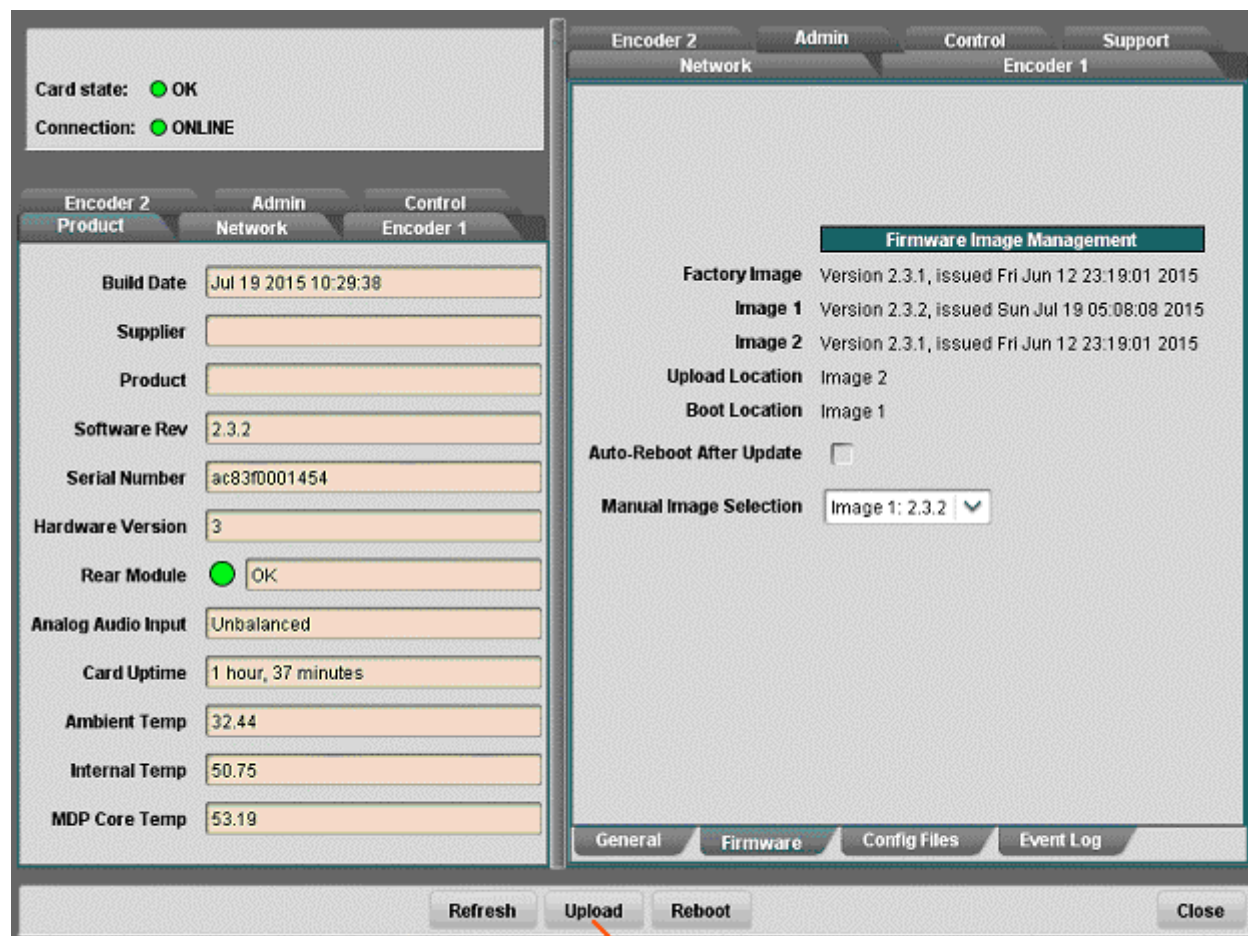

Click here to start firmware update

The fields in the Firmware Image Management tab are:

- **Factory Image, Image 1, and Image 2:** These contain version and release date information for the corresponding firmware images. If no image is present, this field will indicate **No Image**.
- **Upload Location:** This field contains the location where the image upload will go. The 9990-ENC-H264-IP automatically chooses a location that will not overwrite the currently running image.
- **Boot Location:** This field indicates which image will be used in the next boot. If an image is successfully uploaded through Dashboard, this automatically changes to point to that image. It can also be manually changed.

- Auto-Reboot After Update:** This field controls whether or not the 9990-ENC-H264-IP will automatically reboot after a successful firmware upload through Dashboard. By default, the 9990-ENC-H264-IP will **not** reboot after an update. You can upload the firmware at any time, and reboot later during a maintenance window.

Admin Config Files Tab

As you make configuration changes to the 9990-ENC-H264-IP, they are automatically persisted in non-volatile storage. If the unit is rebooted or power-cycled, it will come back in the same configuration.

In addition to automatic configuration persistency, the 9990-ENC-H264-IP also offers the ability to save up to 5 complete configurations, load them, and even export them. This can be used to quickly configure it for different scenarios, or for saving configuration “checkpoints” as a complex configuration is built. Since configurations can be exported, they can be archived outside the unit as well.

Finally, the 9990-ENC-H264-IP also offers 5 pre-saved configuration templates for some common scenarios.

The layout of the Admin Config Files tab is shown below.

Configuration Management							
Config	Status	Name	Config	Config	Config	Download Config	
1	Saved	Manual Example	Load	Delete	Save	Config 1.ogd	Save
2	Saved	IPTV Distribution	Load	Delete	Save	Config 2.ogd	Save
3	Empty		Load	Delete	Save	Config 3.ogd	Save
4	Empty		Load	Delete	Save	Config 4.ogd	Save
5	Empty		Load	Delete	Save	Config 5.ogd	Save

Preset Configurations		
Status	Description	Template
OK	Composite to Eth 1 and 2 Multicast	Load
OK	SD-SDI to Eth 1 and 2 Multicast	Load
OK	720p to Eth 1 and 2 Multicast	Load
OK	1080i to Eth 1 and 2 Multicast	Load
OK	1080i+SD from VID1 to Eth 1 and 2 Multicast	Load

Clear Current Configuration

Status Message Areas

User-Saved Configurations

The fields in the user-saved configuration are:

- **Status:** This indicates whether there is a saved configuration on that particular slot. It will contain the words **Saved** or **Empty**.
- **Name:** This is an optional name for the configuration. It is not required but highly advisable. The name can be edited at any time (even when there is no saved configuration).
- **Config Load Button:** If you click on this button, the corresponding configuration is loaded in the 9990-ENC-H264-IP. It will replace the currently-running configuration. Dashboard™ will take a few seconds to reload (longer if you are accessing over a wide-area network), but the actual configuration in the 9990-ENC-H264-IP is virtually instantaneous. The Status Message Area will indicate the result of the operation.
- **Config Delete Button:** If you click on this button, the corresponding configuration and its description are deleted.
- **Config Save Button:** If you click on this button, the current configuration is saved on the corresponding slot, possibly replacing the configuration saved there if it is not empty.
- **Download Config:** If you click on the **Save** button, the corresponding file is downloaded to your computer. This feature is provided to allow configuration backups.

If you save a configuration to your computer, and later wish to restore it to the 9990-ENC-H264-IP, use the following procedure:

1. On Dashboard™, open the user interface for the frame controller (slot 0).
2. Select the **Data Safe** tab in the configuration area.
3. Uncheck the **Disable** checkbox corresponding to the card you wish to restore the configuration. This step is depicted below.

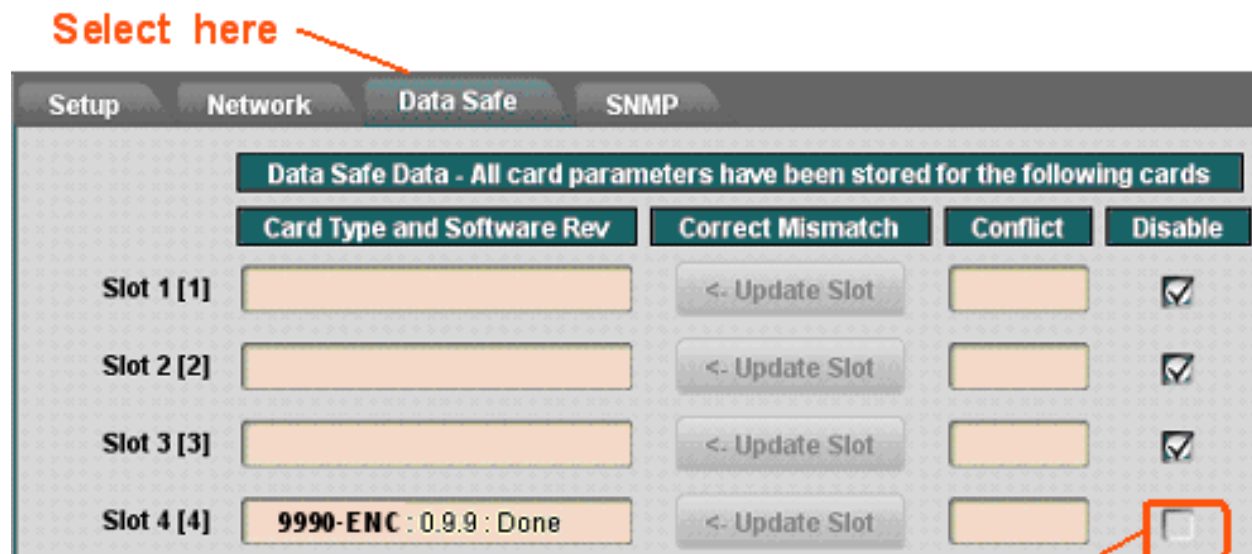

Uncheck this 

- On the Dashboard™ Tree View, right-click on the card, and select **Restore Configuration**. Follow the prompts and navigate to the file you wish to restore. You can also use this process to copy the configuration from one running encoder to another, even if the encoders are on different frames or are of different types (e.g., it is possible to copy configuration between openGear 9990-ENC-H264). This process is illustrated below:

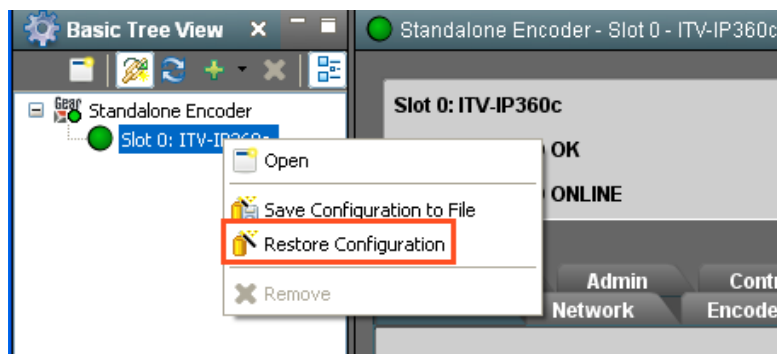

This process is discussed in further detail in the **Dashboard User Manual**, chapter 5, section **Restoring Configurations to Devices**.

Pre-defined Templates

The 9990-ENC-H264-IP offers 5 pre-defined configuration templates, as indicated below.

Status	Description	Template
OK	Composite to Eth 1 and 2 Multicast	Load
OK	SD-SDI to Eth 1 and 2 Multicast	Load
OK	720p to Eth 1 and 2 Multicast	Load
OK	1080i to Eth 1 and 2 Multicast	Load
OK	1080i+SD from VID1 to Eth 1 and 2 Multicast	Load

To load a template, just click on the **Load** button next to it. The pre-defined templates are;

- Composite to Eth 1 and 2 Multicast:** This template configures Encoder 1 to take a composite input on Video 1 and send over UDP/IP multicast to Ethernet 1 and 2 simultaneously. In a dual-channel encoder, the second channel will be stopped.
- SD-SDI to Eth 1 and 2 Multicast:** This template configures Encoder 1 to take an SD-SDI input on Video 1 and send over UDP/IP multicast to Ethernet 1 and 2 simultaneously. In a dual-channel encoder, the second channel will be stopped.

-
- **720p to Eth 1 and 2 Multicast:** This template configures Encoder 1 to take an HD-SDI 720p input on Video 1 and send over UDP/IP multicast to Ethernet 1 and 2 simultaneously. In a dual-channel encoder, the second channel will be stopped.
 - **1080i to Eth 1 and 2 Multicast:** This template configures Encoder 1 to take an HD-SDI 1080i input on Video 1 and send over UDP/IP multicast to Ethernet 1 and 2 simultaneously. In a dual-channel encoder, the second channel will be stopped.
 - **1080i+SD from VID 1 to Eth 1 and 2 Multicast:** This template configures both encoders to run from an HD-SDI 1080i input connected to Video 1. Encoder 1 runs at full resolution, Encoder 2 downscales the content to SD. Encoders are routed to individual multicasts on both Ethernet ports.

Clear Current Configuration Button

The **Clear Current Configuration** button clears all the configured parameters and brings them to their factory defaults. The encoders will be stopped, configured with a default set of parameters, and set to disabled UDP/IP outputs.

The button does not affect the following areas:

- The settings in the **Network** tab are not changed.
- The settings in the **Admin General** tab are not changed.
- Saved configurations are not modified in any way.

Dashboard™ will take a few seconds to reload (longer if you are accessing over a wide-area network), but the actual configuration in the 9990-ENC-H264-IP is virtually instantaneous. The Status Message Area will indicate the result of the operation.

Admin Event Log Tab

The 9990-ENC-H264-IP includes an Event Log in non-volatile storage. This event log can be used for fault-finding, and to check for error conditions. The following information is included in each 9990-ENC-H264-IP event in the log:

- **Date:** The calendar date in which the event occurred.
- **Time:** The time at which the event occurred.
- **Severity:** The severity of the event. The 9990-ENC-H264-IP defines three severity levels:
 - **Error:** These are events that affect the operation of the device. For example, an encoder losing video input. An error will impact service until addressed.
 - **Warning:** These are events that may produce visible glitches, but they do not have a continuous service impact. One example is the ARP renewal failure.
 - **Info:** These are informational events. All configuration actions are logged with this severity. When an error is cleared (for example, a Video Input regains lock), the event is logged with this severity as well.
- **Subsystem:** The subsystem affected by the event. This may be a port, a stream, or the device itself.

- **Event:** This is a textual description of the event. Some events are self-explanatory, and some are intended for product support. Please contact Product Support if you need clarification on any event logged by this device.

The 9990-ENC-H264-IP does not have a battery-backed real-time clock. It depends on the frame controller to obtain the current date and time, and the frame controller depends on an external Network Time Protocol (NTP) server to obtain current date and time. By default, the 9990-ENC-H264-IP will initialize its internal time-of-day clock to January 1, 2010, GMT. If the frame controller is NTP-synchronized, the 9990-ENC-H264-IP will then accept time from it and set its time-of-day clock accordingly.

In order to configure the frame controller for NTP, open its configuration screen on Dashboard™, select the **Network** Tab, and enter the IP address of an available NTP server:

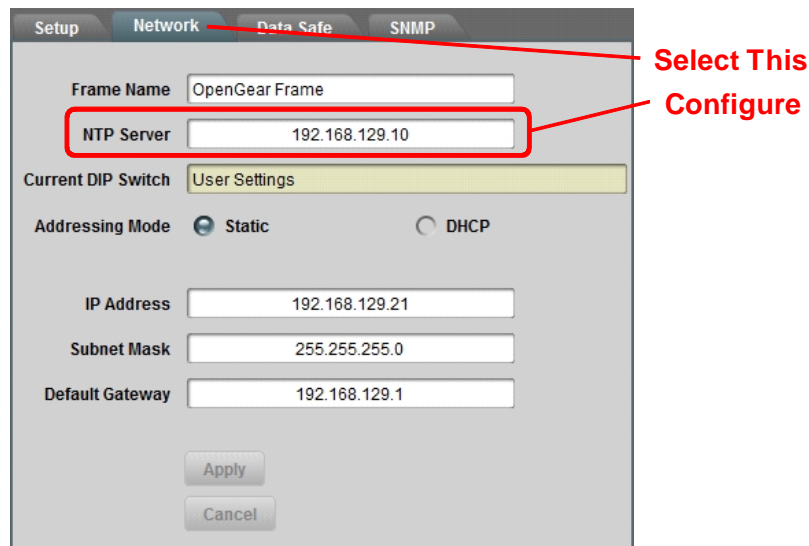

If your frame controller has access to the Internet, you can point it to one of the public NTP servers for your region. You can find more details on this link:

<http://psp2.ntp.org/bin/view/Servers/WebHome>

The full Admin Event Log tab is displayed below:

Log Download

Log View All Error Warning Info

Event Log				
Date	Time	Severity	Subsystem	Event
07/19/15	10:38:01	Info	System	Saved configuration 2
07/19/15	10:37:55	Info	System	Saved configuration 1
07/19/15	10:04:32	Info	Ethernet 1	Configured: address 10.10.9.30 mask 255.255.255.0 gateway 0.0.0.0
07/19/15	09:30:16	Info	ENC2	Video input locked
07/19/15	09:30:16	Info	ENC1	Video input locked
07/19/15	17:30:13	Info	System	Persistent configuration restored
07/19/15	17:30:12	Info	System	Started serial ac83f0001454 ver 2.3.2
07/19/15	09:30:04	Info	System	Control Process Manually Terminated
07/19/15	08:44:45	Info	ENC2	VID1 (enc2) overrun cleared
07/19/15	08:44:40	Info	ENC2	VID1 (enc2) overrun detected

Time Zone

Current Time Sun Jul 19 11:00 2015

Note Time starts at 01/01/2010, 00:00 GMT, unless adjusted by NTP

The fields are:

- **Log Download:** The user interface only displays the last 10 events of each type. If you would like to see the whole event log, it can be downloaded to your computer by clicking on the **Save** button. The log will be in CSV format, and it can be opened by any utility that can read text files; ideally, you should use a spreadsheet program such as Microsoft Excel or similar so it is presented in tabular format. The log will be in chronological order, oldest entry to newest.
- **Log View:** The user interface can display the last 10 events. You can choose to see the last 10 events of any kind by selecting **All**, or you can restrict the view only to **Info**, **Warning**, or **Error**. This setting does not affect the log download, it only affects what is displayed.
- **Event Log:** This table presents the last 10 events of the selected type.
- **Time Zone:** To simplify the correlation of the events with your local time, you can set your time zone using this drop-down menu. Note that the 9990-ENC-H264-IP presents a simplified list, with standard GMT offsets. Note that standard GMT offsets do not change back and forth with Daylight Savings; you will need to make this adjustment manually if it is relevant to you.

-
- **Current Time:** This field indicates the 9990-ENC-H264-IP view of what the current date and time is. If your frame is not NTP-synchronized, this is useful to figure out “how long ago did this event happen”.
 - **Clear Log Display:** If you click on this button, it clears all log views. This is useful to quickly identify any new events after the unit has been set up. Note that this action does not clear the logs stored in non-volatile memory.

The 9990-ENC-H264-IP will store up to about 400 kbytes of logs in non-volatile memory. When that limit is reached, the oldest half of the stored logs will be deleted to make space for new logs.

Support Tab

If you need to contact Technical Support, please be prepared to provide the following information:

1. A detailed description of the problem, and any actions taken to solve it.
2. A detailed description of the environment around the encoder. This includes the make and model of any decoders being used, as well as the connection network (IP or ASI) between the encoder and the decoders.
3. The Technical Support information from the encoder itself. This is downloaded from the **Support** tab:

Select the **Support** Tab, and click on the **Save** button next to **Support Info Download**. This will create a file called **TECHSUPPORT.TXT** in the computer running DashBoard.

The **TECHSUPPORT.TXT** file contains the following information:

- The current configuration of the unit
- A copy of the Event Log (which can also be obtained via the Admin Event Log Tab)

This file does not contain any information that would allow remote access to the unit. However, if you are using RTMP or HLS, this file will contain any access credentials (usernames, passwords) configured in the unit. Passwords will be encrypted.

Playing Video on a Web Page

In general, there are two ways of playing video on a web page:

- Using a web-browser plugin
or
- Using the HTML5 `<VIDEO>` tag, for browsers that support it

Unfortunately, the HTML5 standard did not actually specify what type of audio/video encoding and container was to be supported. Therefore, even though the current versions of all major browsers support the `<VIDEO>` tag, there is no single format that will work on all browsers. Moreover, since the 9990-ENC-H264-IP is an encoder designed primarily for the broadcast market, it uses the transport stream container, which is not supported natively by any browser⁷. Therefore, it is not possible to use the HTML5 `<VIDEO>` tag with content generated by the 9990-ENC-H264-IP.

In order to play the bitstream coming from the 9990-ENC-H264-IP in a web page, a plugin with the appropriate audio, video and container support must be installed in the web browser. The Open-Source VideoLAN player includes appropriate plugins that will work with the bitstream coming from the 9990-ENC-H264-IP. The VideoLAN player can be downloaded from:

<http://www.videolan.org/vlc/>

There are two types of plugins:

- ActiveX controls, used by Internet Explorer
- “Mozilla” (Netscape) style plugins, used by most other browsers (Firefox, Chrome, Safari)

When installing the VideoLAN player, make sure to select the appropriate plugins for the browsers you intend to use. The figure below indicates the choices to be made during the VideoLAN installation in order to get the plugins installed on a Windows PC. If multiple browser support is required, both types of plugins can be selected (but at least one “Mozilla-style” browser must be already installed).

We recommend VideoLAN version 2.0.1 or later. Earlier versions had stability problems with the Mozilla plugin and did not support HTTP Live Streaming.

⁷ A number of browsers support the MP4 container format, but this container does not support real-time encoded video.

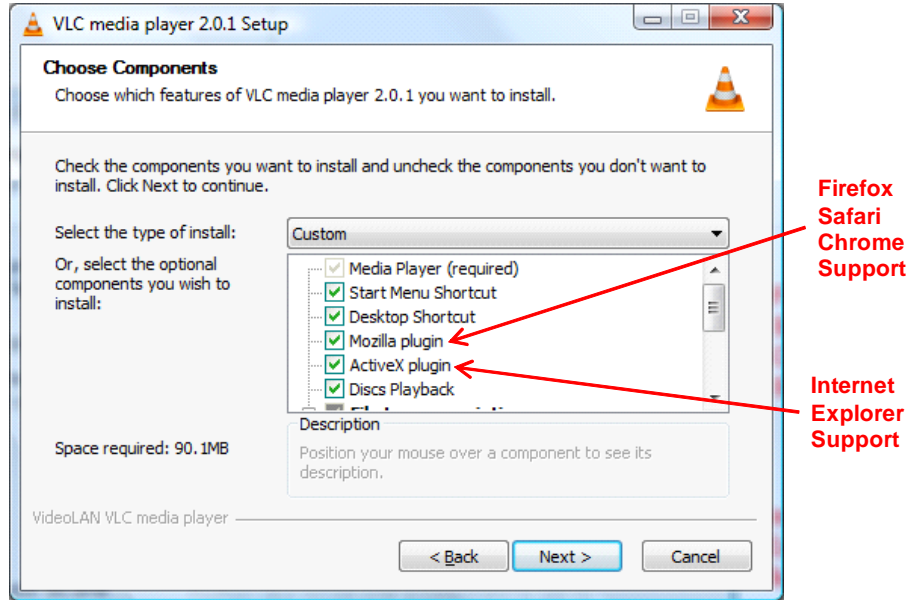

Web Pages Served by the 9990-ENC-H264-IP

The 9990-ENC-H264-IP automatically generates web pages that will display the video being encoded, depending on the output mode of the encoder channels (please refer to the Encoder Output Tab section). The pages will be available for the following output protocols:

- UDP/IP Streaming, as long as IP Outputs with multicast destination IP addresses have been defined.
- Direct HTTP Streaming.
- HTTP Live Streaming, when configured to use the local server.

The web pages generated by the 9990-ENC-H264-IP assume that the VideoLAN plugin has been installed to provide playback services.

To get started, simply point a web browser to the IP address of the desired 9990-ENC-H264-IP Ethernet port:

http://encoder_ip

The 9990-ENC-H264-IP will respond with a Web page with the appropriate links to access the streams, depending on the current configuration. Note that the pages served by each Ethernet port may be different; for example, if the encoders are set to ASI/IP streaming, and no IP Outputs are defined for a given Ethernet port, the web page served from it will indicate that there are no streams available.

The next page shows a few examples of how these web pages look like, depending on the encoder settings.

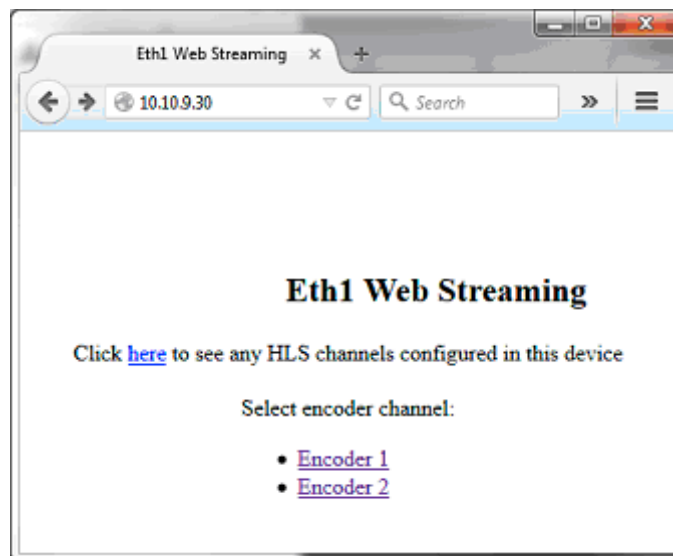
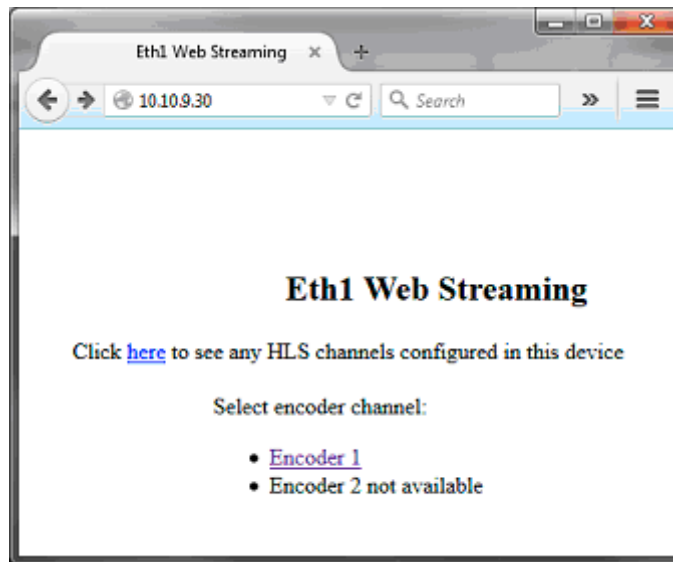
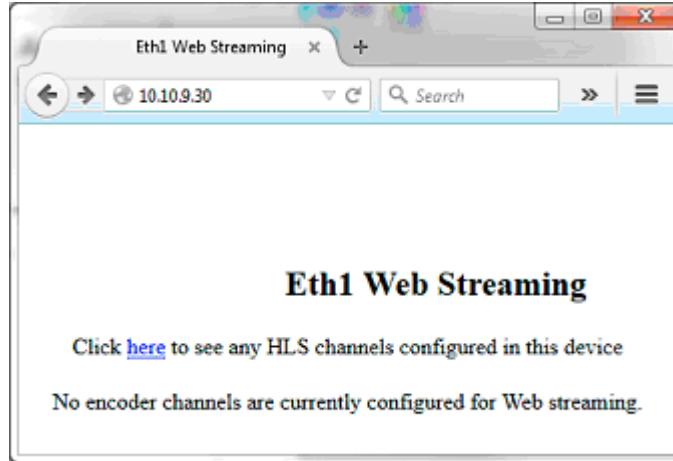

Multicast Streaming

If an encoder is set for UDP/IP Streaming with multicast destination addresses (i.e., with a destination IP address in the range of 224.0.0.0 to 239.255.255.255), the 9990-ENC-H264-IP will generate a web page for that output in the relevant Ethernet port. Note that the video will only actually play if the network between the client and the encoder supports multicast. This will typically be the case if the encoder and the client are in the same subnetwork, but may not work across routers unless they have multicast support enabled, and will definitely not work across the Internet.

The relevant pages are shown below. Both UDP and RTP are supported.

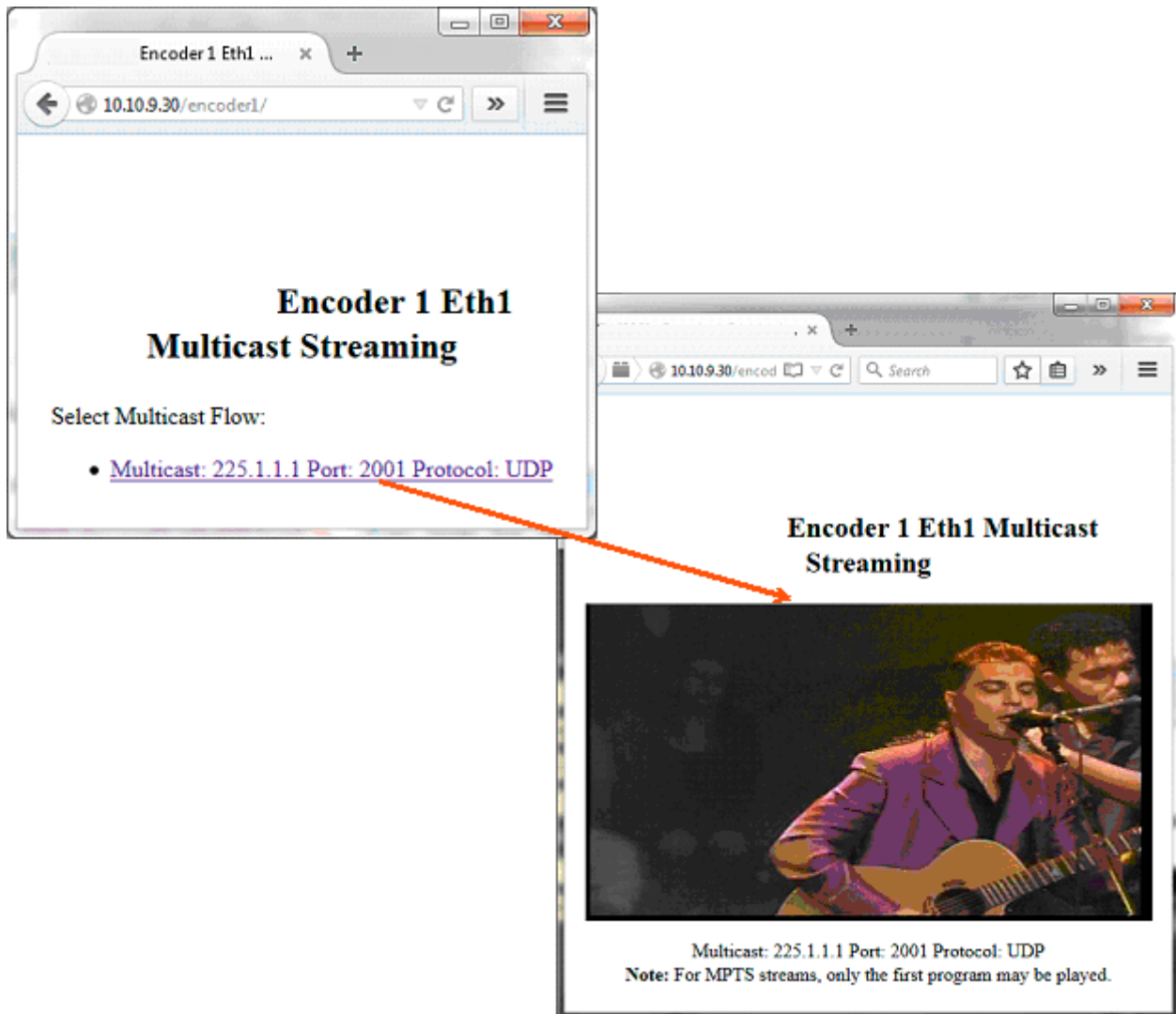

HTTP Live Streaming

All the web pages accessible from the Ethernet ports of the 9990-ENC-H264-IP include a link for the built-in HTTP Live Streaming server page:

If the IP address of the port being accessed is `xxx.xxx.xxx.xxx`, the available local HLS channels can also be accessed through this direct link:

`http://xxx.xxx.xxx.xxx/HLS/`

The page accessed through this link will display a list of available local HLS channels, with the value configured for **Program Name** as the label:

Note that HLS channels configured for remote servers will not be listed in this page, as the 9990-ENC-H264-IP has no way of knowing the actual link to these channels.

Clicking on the link will cause the content to play. For Apple devices (iPods, iPads, iPhones, etc.), this will launch the built-in media player; for PCs running Windows (and possibly Linux), if the VLC plugin is installed, the video will play in the web page.

Direct HTTP Streaming

If an encoder channel is configured for Direct HTTP Streaming, the selection happens as depicted below. Unlike multicast, Direct HTTP Streaming will work over the Internet as long as the path from the encoder to the client has sufficient bandwidth. Direct HTTP Streaming is always available on both Ethernet ports.

If the 9990-ENC-H264-IP is required to support clients on remote networks, make sure that a Default Gateway is entered in the corresponding Ethernet port configuration (see the Network Configuration Tab section). When replying to a request, the 9990-ENC-H264-IP will always use the Ethernet port where it received the request from.

Using a Firewall between the 9990-ENC-H264-IP and the Internet

Since both Direct HTTP Streaming and HTTP Live Streaming work over the Internet, in some situations it may be desirable to do so (for example, to allow for remote monitoring). It is assumed to be safe to connect the 9990-ENC-H264-IP Ethernet ports directly to the Internet with a public IP address; however, this may not be desirable. It is possible to place a port-forwarding firewall between the 9990-ENC-H264-IP and the Internet; the web pages and the streaming will still work as long as the firewall is configured **not** to remap the Direct HTTP Streaming **Listening Port** (see the Direct HTTP Streaming configuration section). For example, if the Listening Port is configured to be 8000, the firewall must be configured to remap external port 8000 to internal port 8000. The reason for this requirement is that the plugin needs to know the listening port, and that value is passed to it by the automatically-generated pages from the 9990-ENC-H264-IP.

Web Browser Support

The web pages generated by the 9990-ENC-H264-IP are known to work with the VideoLAN plugin versions 2.0.1 to 2.0.5 and the following web browsers (Windows):

- Internet Explorer versions 9.0.2 – 9.0.13
- Mozilla Firefox versions 7.0 – 39.0
- Google Chrome versions 14.0.835.186 – 24.0.1312.57
- Apple Safari 5.1 – 5.1.7

Other browsers and operating systems may work, as long as the VideoLAN plugin is installed.