

User's Manual

For

BH-MSD-6A Micro Stepping Driver

Attention: Please read this manual carefully before using the driver!

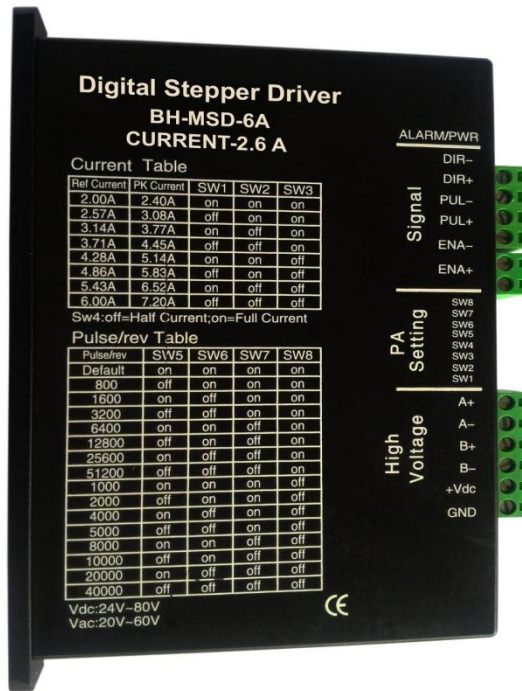

COMMITTED TO PRECISION

Version - 1.01

BHOLANATH PRECISION ENGINEERING PVT.LTD.

Website:-www.bholanath.in
E-mail id:-support@bholanath.in

Table of Contents

1. Introduction, Features and Applications	4
Introduction	4
Features.....	4
Applications.....	4
2. Specifications	4
Electrical Specifications	4
Model no:-BH-MSD-6A	4
Drive prevention.....	4
Operating Environment	4
Elimination of Heat.....	5
3. Pin Assignment and Description.....	5
Connector P1 Configurations	5
Connector P2 Configurations	5
External Limiting Resistance	5
Full current And Half current	5
Wiring Notes.....	6
Switch choice.....	6
4. Connecting the Motor	6
Connections to 4-lead Motors.....	6
Connections to 6-lead Motors.....	6
Half Coil Configurations.....	7
Full Coil Configurations	7
Connections to 8-lead Motors.....	7
Series Connections.....	7
Parallel Connections	7
5. Power Supply Selection	8
Regulated or Unregulated Power Supply.....	8
Multiple Drivers	8
6. Troubleshooting	8
7. Dimensions	10
8. Circuit connections.....	11
9. Frequently Asked Questions	11
10. Contact Us.....	12

1. Introduction, Features and Applications

Introduction

Micro stepping driver is particularly suitable for the applications desired with extremely low noise and low temperature rise technology which significantly improve the performance of the stepper motor that leads to low temperature rise, low vibration. With the adjustment technology (step/rev and current) according to different motors, the driven motors automatically generate optimal parameters for different motors, and achieve the best performance at higher speed. It is suitable for driving 2-phase and 4-phase hybrid stepping motors.

Features

- High performance, cost-effective
- Suitable for 2-phase and 4-phase motors
- Support PUL/DIR and CW/CCW modes
- Short-voltage, over-voltage, over-current and short-circuit protection
- Low temperature rise, smooth motion

Applications

Suitable for a wide range of stepping motors, from NEMA size 17 to 34. It can be used in various kinds of machines, such as X-Y tables. And a variety of large-scale automation equipments and instruments. For example: labeling machine, cutting machine, packaging machine, plotter, engraving machine, CNC machine tools and so on. It always performs well when applied for equipment which requires for low-vibration, low-noise, high-precision and high-velocity.

2. Specifications

Electrical Specifications

Model No:-BH-MSD-6A

Parameter	Min	Typical	Max	Unit
Input Voltage(DC)	24	-	80	VDC
Input Voltage(AC)	20	-	60	VAC
Output current	2	-	6	A

DRIVE PREVENTION :-

NOTE:- THE ABOVE VOLTAGE MAY DIFFER ACCORDING TO THE POWER SUPPLY IT IS RECOMMENDED THEORITICALLY TO USE ABOVE VOLTAGE AS IT WILL PREVENT DRIVE FROM DAMAGE.

Operating Environment

Cooling	Natural cooling or Forced cooling
Operating Environment	Environment-Avoid dust, oil fog, corrosive gases Temperature- -10°C — 45°C Humidity-No Condensation, No Water Droplets Operating Temperature- -10°C-45°C
Storage Temperature	-20°C — 65°C

Elimination of Heat

- Driver's reliable working temperature should be <70°C, and motor working temperature should be <80°C;
- It is recommended to use automatic idle-current mode, namely current automatically reduce to 60% when motor stops, so as to reduce driver heating and motor heating;
- It is recommended to mount the driver vertically to maximize heat sink area. Use forced cooling method to cool the system if necessary.

3. Pin Assignment and Description

The driver has two connectors namely P1 & P2, Connector P1 for control signals connection, Connector P2 for power and motor connections. The following tables are brief descriptions of the two connectors.

Connector P1 Configurations

Pin Function	Details
PUL+,CP+	PULSE SIGNAL POSITIVE
PUL-,CP-	PULSE SIGNAL NEGATIVE
DIR+,CW+	DIRECTION SIGNAL POSITIVE
DIR-,CW-	DIRECTION SIGNAL NEGATIVE
ENA+,FREE+	ENABLE SIGNAL POSITIVE
ENA-,FREE-	ENABLE SIGNAL NEGATIVE

Connector P2 Configurations

Pin Function	Details
V+	DC POWER SUPPLY/AC POWER SUPPLY
GND	GROUND
A+,A-	MOTOR PHASE A
B+,B-	MOTOR PHASE B

EXTERNAL CURRENT LIMITING RESISTANCE: Signal current in both the“+” “-”ports, can't be too big and not too weak. It is necessary to connect current-limiting resistor in external if the signal amplitude is too strong, refer to following table

VOLTAGE	LIMITING RESISTANCE(R)
5 V	R=0
12 V	R=1KΩ
24 V	R=2.2 KΩ

NOTE: FULL CURRENT AND HALF CURRENT CHOICE: (PORT SW 4)

FULL CURRENT:-IF THE DRIVER IS IN FULL CURRENT MODE THIS WILL LEAD TO MOTOR HEAT AND IT WILL ALSO DAMAGE THE DRIVER.

HALF CURRENT:-THE DRIVER SHOULD ALWAYS BE IN HALF CURRENT MODE AS THIS WILL REDUCE THE HEAT OF MOTOR AND DRIVER.

Wiring Notes

- To prevent noise incurred in PUL/DIR signal, pulse/direction signal wires and motor wires should not be tied up together. It is better to separate them by at least 10 cm; otherwise the disturbing signals generated by motor will easily disturb pulse direction signals, causing motor position error, system instability and other failures.
- If a power supply serves several drivers, separately connecting the drivers is recommended instead of daisy-chaining.
- It is prohibited to pull and plug connector P2 while the driver is powered ON, because there is high current flowing through motor coils (even when motor is at standstill). Pulling or plugging connector P2 with power on will cause extremely high back-EMF voltage surge, which may damage the driver.

Switch Choice: (“ON=0, OFF=1”)

1. Microstepping choice:

SW 5	0	0	0	0	0	0	0	0	1	1	1	1	1	1
SW 6	0	1	0	1	0	1	0	1	0	1	0	1	0	1
SW 7	0	0	1	1	0	0	1	1	0	0	1	1	0	0
SW 8	0	0	0	0	1	1	1	1	0	0	0	0	1	1
STEP/REV	Default t	800	1600	3200	6400	12800	25600	51200	1000	2000	5000	10000	250000	50000

2. Current choice:

SW 1	0	1	0	1	0	1	0	1
SW 2	0	0	1	1	0	0	1	1
SW 3	0	0	0	0	1	1	1	1
CURRENT(A)	2.00A	2.57 A	3.14 A	3.71 A	4.28 A	4.86 A	5.43 A	6.00 A

4. Connecting the Motor

Connections to 4-lead Motors

4 lead motors are the least flexible but easiest to wire. Speed and torque will depend on winding inductance.

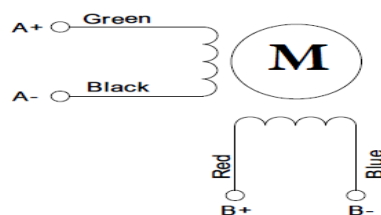

Connections to 6-lead Motors

Like 8 lead stepping motors, 6 lead motors have two configurations available for high speed or high

torque operation. The higher speed configuration, or half coil, is so described because it uses one half of the motor's inductor windings. The higher torque configuration, or full coil, uses the full windings of the phases.

Half Coil Configurations

As previously stated, the half coil configuration uses 50% of the motor phase windings. This gives lower inductance, hence, lower torque output. Like the parallel connection of 8 lead motor, the torque output will be more stable at higher speeds. This configuration is also referred to as half chopper.

Page | 7

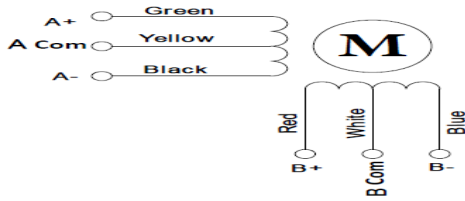

FOR HALF COIL CONNECTION

CONNECT (A+)-A Com & (B+)-B Com/
A Com-(A-) & B Com-(B-)

6-lead motor half coil (higher speed) connections

Full Coil Configurations

Lower speeds is desired. This configuration is also referred to as full chopper. In full coil mode, the motors should be run at only 70% of their rated current to prevent overheating.

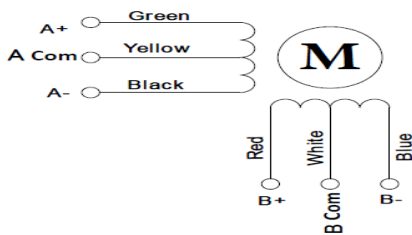

FOR FULL COIL CONNECTION

CONNECT (A+)-(A-) & (B+)-(B-)
LEAVE A Com & B Com OPEN

6-lead motor full coil (higher torque) connections

NOTE: THE ABOVE CONFIGURATIONS IS FOR CONNECTING IN A BIPOLAR MICROSTEP DRIVE AS PER APPLICATION/NON-AVAILABILITY OF A UNIPOLAR MICROSTEP DRIVE.

Connections to 8-lead Motors

8 lead motors offer a high degree of flexibility to the system designer in that they may be connected in series or parallel, thus satisfying a wide range of applications.

Series Connections

A series motor configuration would typically be used in applications where a higher torque at lower speeds is required. Because this configuration has the most inductance, the performance will start to degrade at higher speeds. In series mode, the motors should also be run at only 70% of their rated current to prevent overheating.

1. Bipolar (series) connection

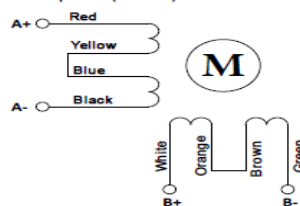

8-lead motor series connections

Parallel Connections

An 8 lead motor in a parallel configuration offers a more stable, but lower torque at lower speeds. But because of the lower inductance, there will be higher torque at higher speeds.

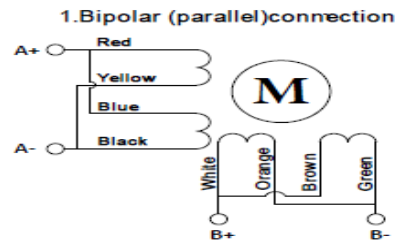

8-lead motor parallel connections

5. Power Supply Selection

The Microstep Driver can match Large and small size stepping motors (from Nema size 17 to Nema size 34). To achieve good driving performances, it is important to select supply voltage and output current properly. Supply voltage determines the high speed performance of the motor, while output current determines the output torque of the driven motor (particularly at lower speed). Higher supply voltage will allow higher motor speed to be achieved, at the price of more noise and heating. If the motion speed requirement is low, it's better to use lower supply voltage to decrease noise, heating and improve reliability.

Regulated or Unregulated Power Supply

Both regulated and unregulated power supplies can be used to supply the driver. However, unregulated power supplies are preferred due to their ability to withstand current surge. If regulated power supplies (such as most switching supplies.) are indeed used, it is important to have large current output rating to avoid problems like current clamp. On the other hand, if unregulated supply is used, one may use a power supply of lower current rating than that of motor (typically 50% ~70% of motor current). The reason is that the driver draws current from the power supply capacitor of the unregulated supply only during the ON duration, but not during the OFF duration. Therefore, the average current withdrawn from power supply is considerably less than motor current

Multiple Drivers

It is recommended to have multiple drivers to share one power supply to reduce cost, if the supply has enough capacity. To avoid cross interference, **DO NOT** daisy-chain the power supply input pins of the drivers. (Instead, please connect them to power supply separately).

6. Troubleshooting

1. The status on light's indication

RUN: green, normal work light.

ERROR: red, failure light, the motor with phase short-circuit, overvoltage and undervoltage protection.

NOTE:

TO CHECK IF DRIVE IS OK/NOT OK, CONNECT ONLY SUPPLY (AC /DC) VOLTAGE AND GROUND TO THE MICROSTEP DRIVE AND CHECK THE LED INDICATOR IF IT SHOWS GREEN THEN DRIVE IS OK AND IF THE LED INDICATOR SHOWS RED THEN DRIVE IS NOT OK THIS TEST SHOULD BE DONE WHEN THE BELOW TROUBLES IS CARRIED AND MOTOR IS NOT RUNNING.

2. Troubles

Problems	Possible cause	Solutions
Motor is not rotating	No power supply	Check the power supply
	No control signal	Check the control signal
	The driver is disabled	Don't connected the enable signal or enable the driver
ALM lights	Supply voltage is too high or too low	Check the supply voltage
	Motor line short-circuit	Check motor lines eliminate the short-circuit
	Motor line wrong connect	Check the motor wiring
	Motor or drive failure	Replace the motor or drive
Motor rotates in the wrong direction	Motor phases connected in reverse	Reverse the phases line
	Wrong I/p direction signal	Change direction setting
	Motor line break	Change the phases are connected
Inaccurate Position	The Micro steps set incorrectly.	Set the correct segments
	The motor load is too heavy.	Increasing the current
	Control signal is interfered	Eliminate interference
Motor Stalled	Power supply voltage too low	Increasing the supply voltage
	Accelerating time is too short.	Extend the acceleration time
	Current setting is too small	Increasing the current
	Motor torque is too small	Replace the motor

Problems	Possible cause	Solutions
LED off turn	Wrong connection for power	Check wiring of power
	Low-voltages for power	Enlarge voltage of power
Motor doesn't run, without holding torque	Wrong connection of stepper motor	Correct its wiring
	RESET signal is effective	when offline Make RESET ineffective
Motor doesn't run, but maintains holding torque	Without input pulse signal	Adjust PMW & signal level
Motor's holding torque is too small	Too small relative to current setting	Correct rated current setting
	Acceleration is too fast	Reduce the acceleration
	Motor stalls	Rule out mechanical failure
	Driver does not match with The motor	Change a suitable driver

7. Dimensions

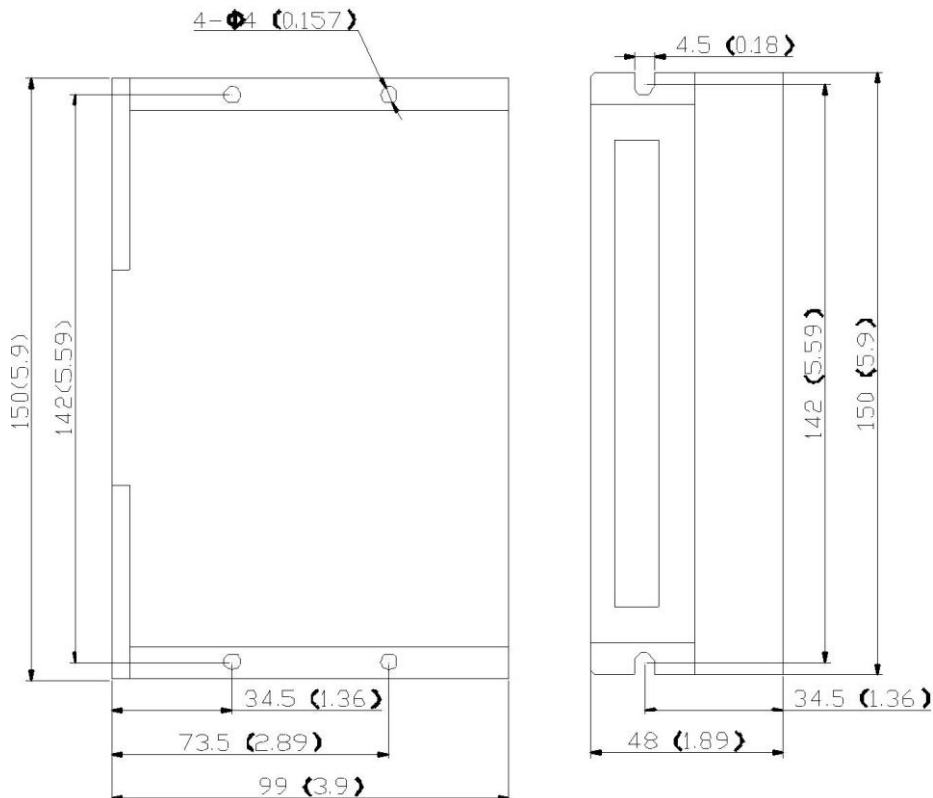

8. Circuit connections

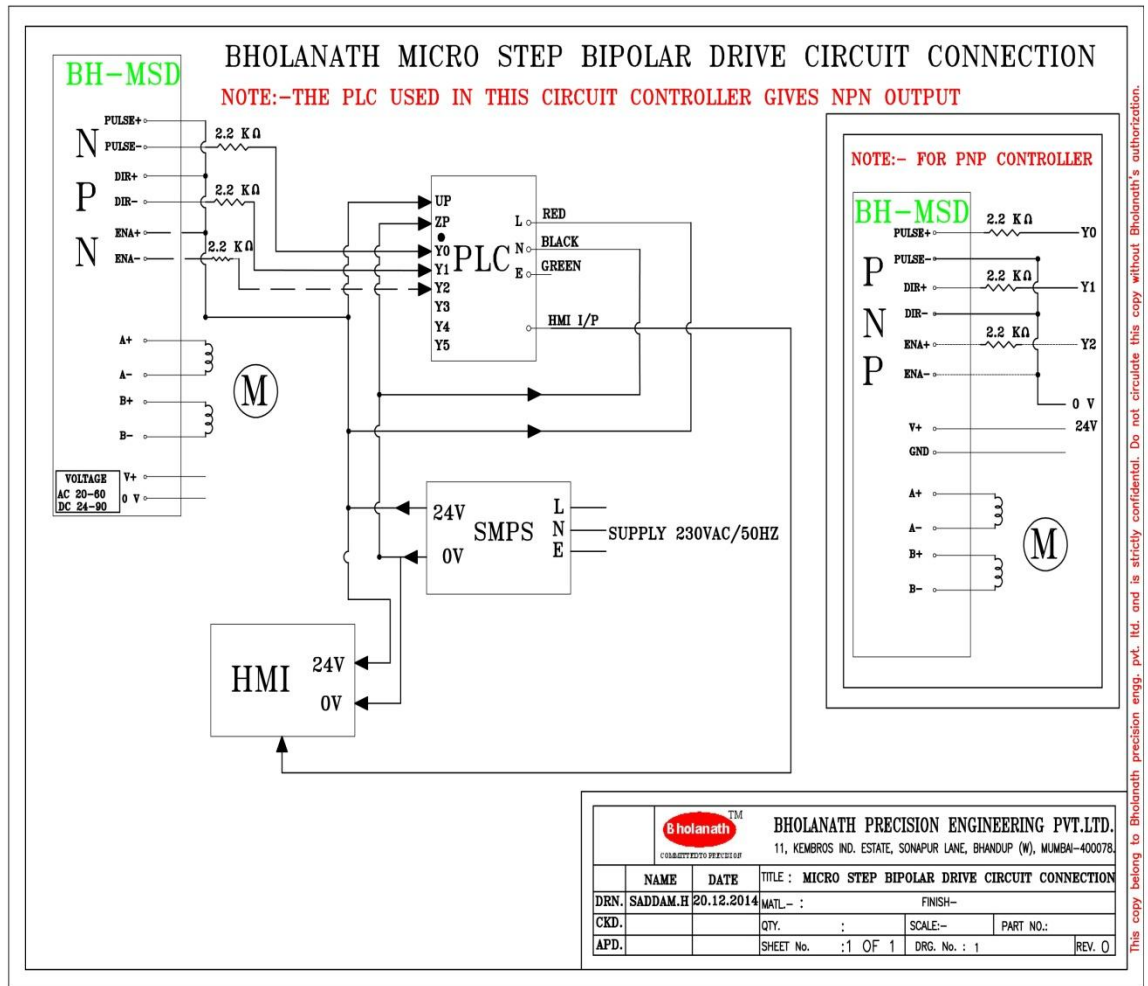

9. Frequently Asked Questions

In the event that your driver doesn't operate properly, the first step is to identify whether the problem is electrical or mechanical in nature. The next step is to isolate the system component that is causing the problem. As part of this process you may have to disconnect the individual components that make up your system and verify that they operate independently. It is important to document each step in the troubleshooting process. You may need this documentation to refer back to at a later date, and these details will greatly assist our Technical Support staff in determining the problem should you need assistance.

Many of the problems that affect motion control systems can be traced to electrical noise, controller software errors, or mistake in wiring.

The content in this manual has been carefully prepared and is believed to be accurate, but no responsibility is assumed for inaccuracies

We manufacture 1.8° HYBRID STEPPER MOTORS of size NEMA17, NEMA23, NEMA24, and NEMA34 in square frame and Nema 23 in Round frame and available in our product range are Linear Actuator Stepper Motors, Planetary Geared Stepper Motors, Stepper motors with Brakes and Customized Stepper Motors.

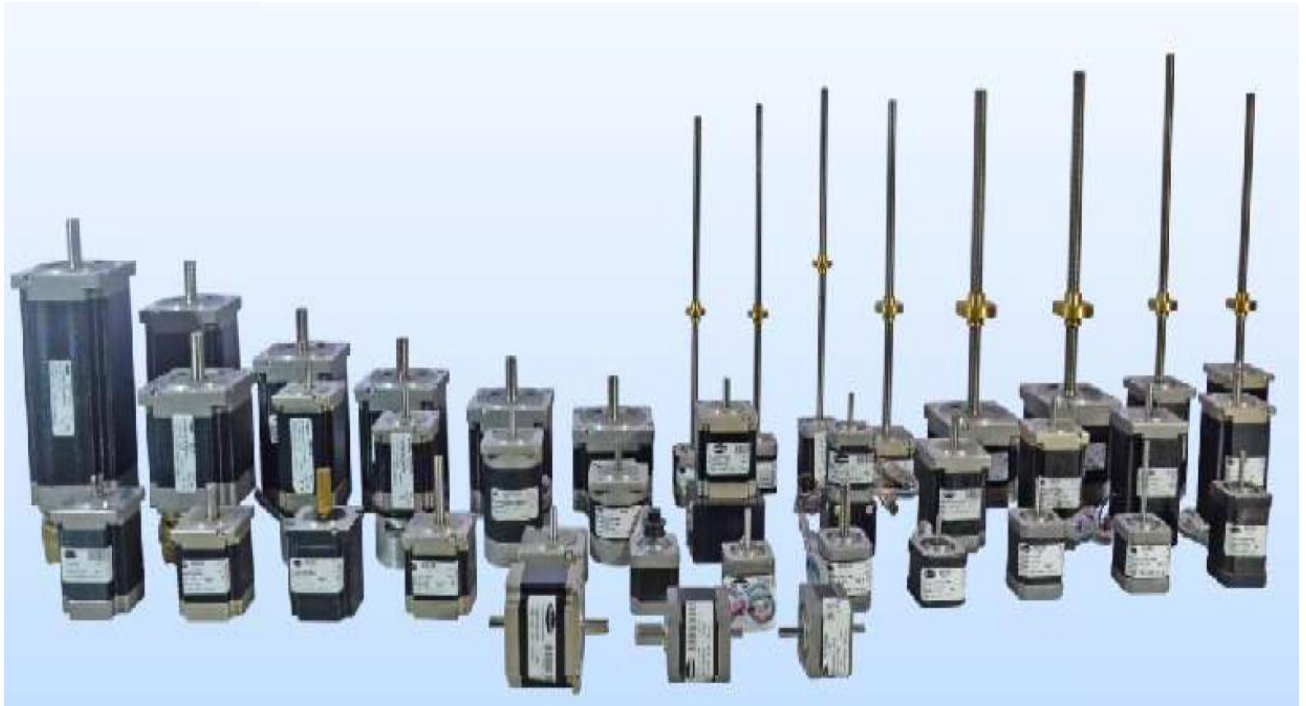

Office Address

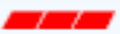
Contact Us 

Bholanath Precision Engineering Pvt.Ltd.

11,Kembros Industrial Estate,Near Asian Paint Company,
Sonapur Lane,Bhandup (West),Mumbai - 400078,India.

Phone No : -

+91 - 9920903825 / 9930514603 / 9821671733 / 9323166582

91 - 22 - 25664338 / 25662856 / 67993260