

/ Marley MW Fan /

User Manual 01-1264A



Installation

Bushing Installation

1—Using a clean dry cloth, remove any dirt, lubricant, or sediment from the bore, the bushing taper and the tapered fan hub.

⚠ Caution

Do not use any lubricant or thread locking compound during installation. The use of such products will cause improper bolt torque and will crack the fan hub.

2—Slide the bushing into the tapered bore of the fan hub. Do not press the bushing into place.

3—Place the bushing bolts through the untapped holes of the bushing into the threaded holes of the hub.

3a—If there are untapped holes in the hub, the bolts can be placed through the untapped holes of the hub into the threaded bushing holes.

4—Tighten the bushing bolts by hand to hold the bushing loosely in the hub.

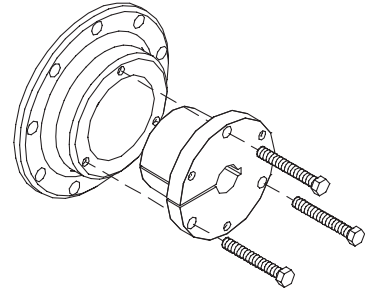

Fan Installation

1—Slide the bushing and fan assembly onto the shaft.

2—Insert the key into the keyway. Some bushings are manufactured with a shallow keyway. If a key is included in the bushing package, use the key supplied by the bushing manufacturer.

3—Using a torque wrench, tighten the bushing bolts evenly one half turn until the proper installation torque is achieved. Proper installation torque is listed on the bushing bolt torque chart.

4—Continue tightening until all bolts are at recommended torque.

⚠ Caution

Do not exceed the torque specification listed on the bushing bolt torque chart. Exceeding the recommended torque will crack the fan hub.

Bushing	Bolt Thread	Bolt Torque Foot - Pounds
JA	10 - 24	5
G	1/4" - 20	6
H	1/4" - 20	6
SH	1/4" - 20	8
SD	1/4" - 20	9
SDS	1/4" - 20	9
P-1	5/16" - 18	13
SK	5/16" - 18	15
SF	3/8" - 16	23
Q-1	3/8" - 16	29
R-1	3/8" - 16	29

Installation

Blade Pitch Adjustment

1—Obtain 21 sets of nuts and bolts to replace existing nuts and bolts (12 sets for the outer bolt circle and bolts between the blades and 9 bolts for the boss section).

2—Remove and replace **all** the bolts and nuts. Do not tighten the bolts yet.

3—Adjust the blade by hand, or lightly tap the blade with a rubber mallet, to set the approximate position.

4—Measure the blade pitch angle. With a machinist's combination square, measure the distance from the hub (flat area between the blade socket) to the top of the blade's trailing edge (at the highest position). Note that the blade's trailing edge is the thinner edge.

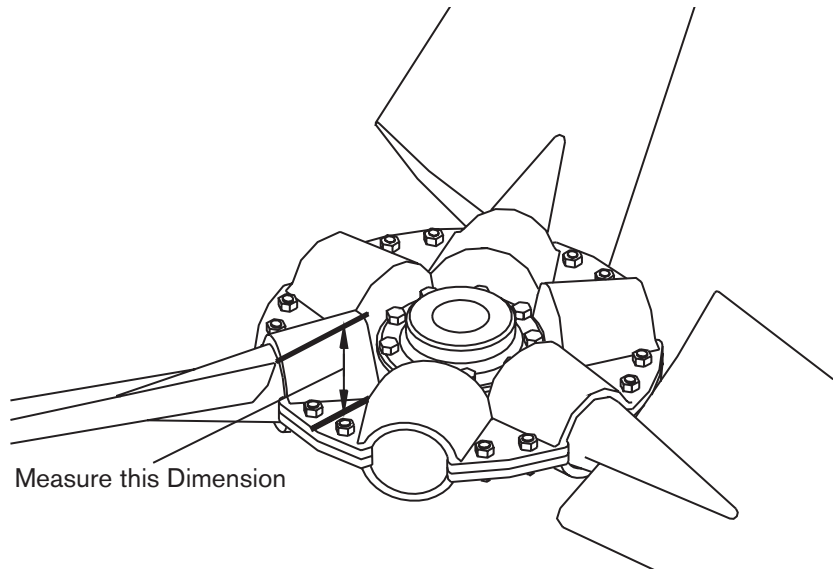

Pitch Angle	Distance From Hub To The Top Of Blade (inches)
25°	3.31
30°	3.71
35°	4.06
40°	4.46
45°	4.73
50°	5.08

Note

Distance for pitch angles not listed in this table can be obtained through interpolation.

5—Tighten nuts and bolts to: 15 foot pounds of torque (stainless bolts).

SPX[®]

COOLING TECHNOLOGIES

7401 WEST 129 STREET | OVERLAND PARK, KANSAS 66213 UNITED STATES | 913 664 7400 | spxcooling@spx.com | spxcooling.com

In the interest of technological progress, all products are subject to design and/or material change without notice.
©2010 SPX Cooling Technologies, Inc. | Printed in USA

Manual 01-1264A