

Power Factor Controllers

RG / RG3 Series



RG3-15C/CS/CL/CLS

With RG-T and RG-B/BS series reactive power control relays, power factor correction is done by measuring the current from single phase. These devices are preferred in systems with balanced loads.

RG3 series, measure the voltage and current of the 3 phases individually thus the power factor correction in systems with unbalanced loads are done accurately.

RG3-15CL/CLS series provide the exact solution for power factor correction of inductive and capacitive loads by switching both capacitors and shunt reactors.

Features;

- Measuring the capacitor power in every step automatically
- Enabling and disabling required steps simultaneously
- Ability to connect single-phase and three-phase capacitors to the system together (RG3-12C/CS-RG3 15C/CS/CL/CLS)
- Adjustable switch-on, switch-off and discharge delay times
- Adjustable Cos ϕ value
- Selectable step number
- 10 different program options
- Equalizing energy values with the utility meters (RG3-12C/CS-RG3-15C/CS/CL/CLS)
- Ability to select on/off options in power cuts (RG3-12C/CS-RG3-15C/CS/CL/CLS)
- Energy rate ratio alarm adjustable between 1 and 240 hours



PRODUCT SELECTION TABLE

Product Code	Size (mm)	Shunt Reactor (3 steps)	Smart Switching	1 Phase, 1 Current Transformer	3 Phase, 3 Current Transformer	1-Phase Capacitor	Three Phase Capacitor	THD Protection	Dual Target Cos	Auto Setup	Password Protection	RS-485 Communication	Internal Thermal Control	External Thermal Control	Pcs / Box
RG-6T	6 Steps	144x144		●			●								4
RG-8T	8 Steps	144x144		●			●								4
RG-12T	12 Steps	144x144		●			●								4
RG-8B-96	8 Steps	96x96	●	●			●	●	●	●	●		●		12
RG-8BS-96	8 Steps	96x96	●	●			●	●	●	●	●	●	●		12
RG-12B	12 Steps	144x144	●	●			●	●	●	●	●				4
RG-12BS	12 Steps	144x144	●	●			●	●	●	●	●	●			4
RG3-12C	12 Steps	144x144	●		●	●	●	●	●	●	●			○	4
RG3-12CS	12 Steps	144x144	●		●	●	●	●	●	●	●	●		○	4
RG3-15C	15 Steps	144x144	●		●	●	●	●	●	●	●				4
RG3-15CS	15 Steps	144x144	●		●	●	●	●	●	●	●	●			4
RG3-15CL	15 Steps	144x144	●	●	●	●	●	●	●	●	●	●			4
RG3-15CLS	15 Steps	144x144	●	●	●	●	●	●	●	●	●	●			4

* RG3-15CL/CLS can be ordered as 14C+1L or 12C+3L.

○ Optional

Performing power factor correction with three-phase capacitors while the loads are balanced and with single-phase capacitors at phases where unbalance loads occur, RG3 series offers a unique solution for balanced and unbalanced loads.

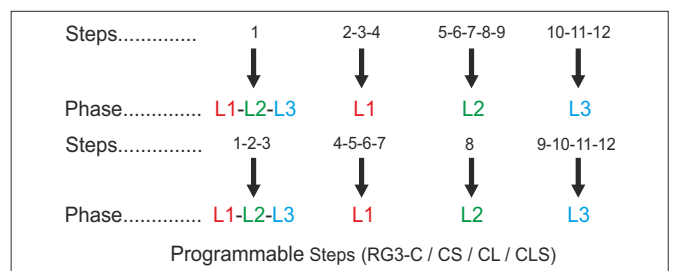
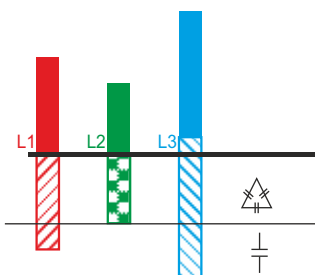

Power Factor Controllers

RG / RG3 Series

MEASURED PARAMETERS

Phase - Neutral Voltages (V_{LN})	Phase Current (I)	Active Power (P)	Apparent Power (S)
	Cos	Reactive Power (Q)	

RG-T series



Individual Voltage Harmonics - up to 19th	Total Harmonic Distortion for Voltage (THD-V)
Individual Current Harmonics - up to 19th	Total Harmonic Distortion for Current (THD-I)

RG-B / RG-BS series



3-Phase Currents (I)	Total Active power (P)	Total Apparent Power (S)	Total Reactive Power (Q)
Active Energy - Import (kWh)	Active Energy - Export (kWh)	Capacitive Reactive Energy (kVArh C)	Inductive Reactive Energy (kVArh L)

RG3-C / RG3-CS series

Power Factor Correction

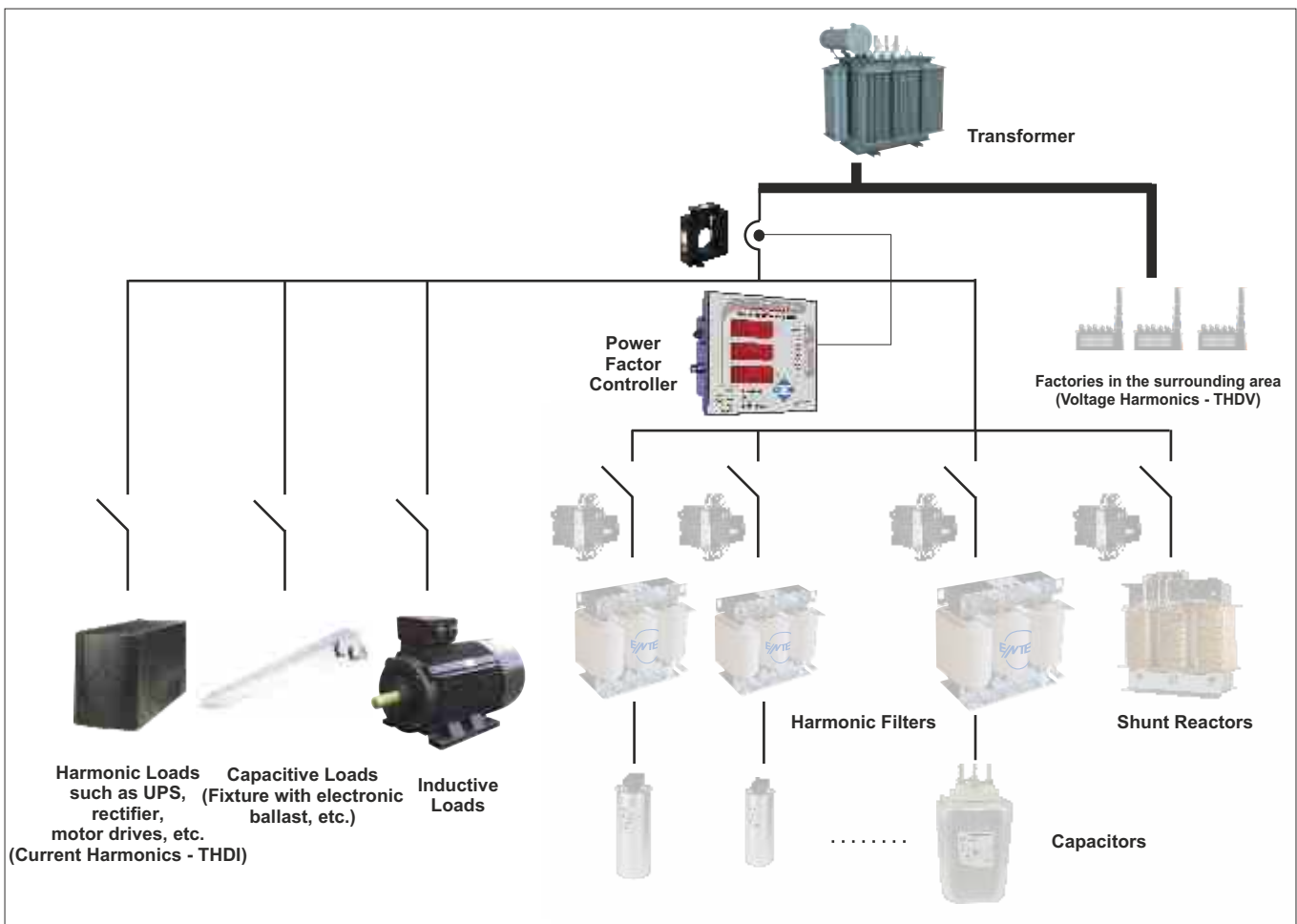

Power Factor Controllers

RG / RG3 Series

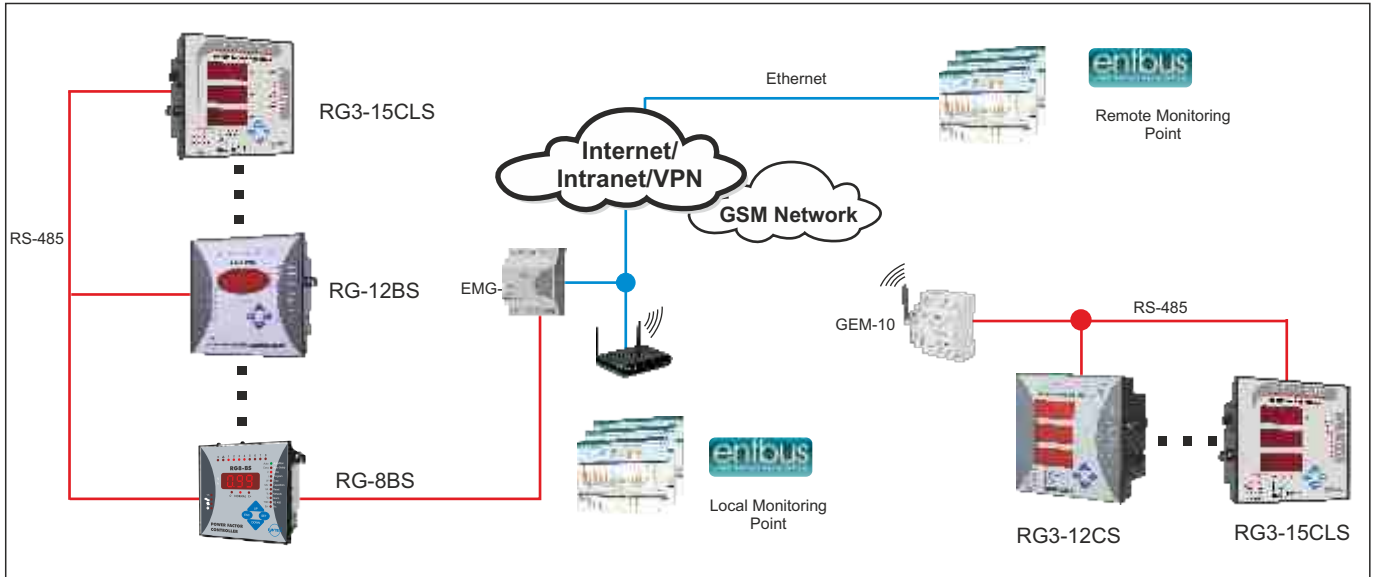

Remote Monitoring for PFC Systems

SPECIFICATIONS

	RG-T	RG-B	RG-BS	RG3-C/CL	RG3-CS/CLS
ENCLOSURE					
Dimensions		144x144mm PR16; 96x96mm PR19 (RG-8B/BS)			
Protection Class		IP40 front panel, IP54 optional			
Weight		0,9kg/pcs (Pr16); 0,6kg/pcs (Pr19) (RG-8B/BS)			
MEASUREMENTS / FUNCTIONS					
Accuracy		1%±1digit(V,I,cos);2%±1digit (W,VAr,VA,harmonics)			
Over Voltage Setting	240-275 VAC	0-500 VAC		0-300 VAC	
Current Range			50mA-5,5A		
Measurement Range with Transformer	50mA-10kA Transformer Ratio 5...10000/5A		50mA-10kA Transformer Ratio:1-2000		
Burden (Input Load)		<2VA Current, < 3VA Voltage			
Cos Setting	0,8<cos <1 inductive		0,8<cos <1 inductive/capacitive		
C/k Setting	0,02-1,00				
Time Delay Between Steps	2-1800 s for switch on / off separately			1-1800 s for switch on / off separately	
Discharge Time Setting		2-1800s		1-1800s	
Programmable THD-V Alarm				●	
Programmable Discharge Time				●	
Programmable Over Voltage Alarm			●		
Automatic Step Calculation			●		
Energy Measurement				●	
Adjustable Energy Ratio Alarm		●			
Displaying Parameters for Each Phase					●
Alarm Contact Output	-		●		
SUPPLY					
Operating Voltage		230 VAC ± 10%			
Operating Frequency		50/60 Hz			
Power Consumption		<10 VA			
INPUT/OUTPUT STRUCTURE					
Step Number	6,8,12	6,8,12		12,15	
Output Contact	3A,750VA cos =1	5A,1250VA cos =1			
AMBIENT CONDITIONS					
Operating Temperature		- 5 ... +55°C			
Ambient Humidity		85%			
CONNECTIONS					
Mounting		Front panel mounting / socket with screw terminal			
Connection Types	Single phase, neutral, 1 current transformer			3 phase, neutral, 3 current transformer 4 wires	



Power Factor Controllers

RG / RG3 Series

Connection Diagrams

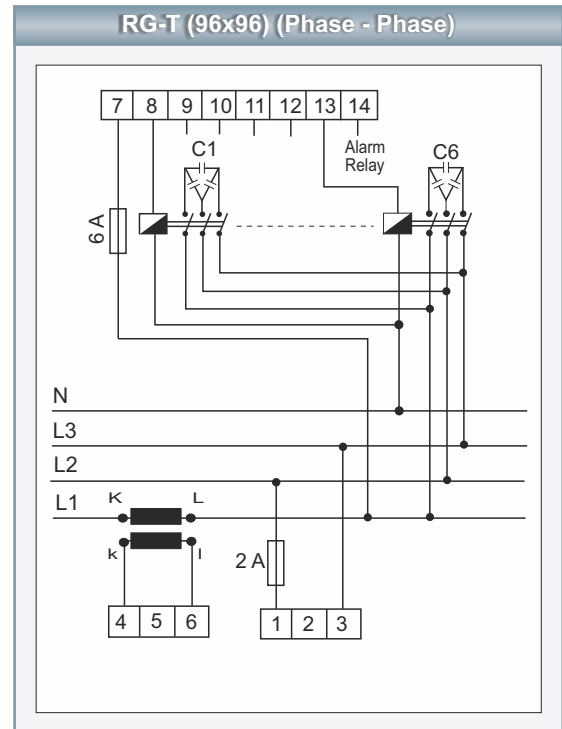
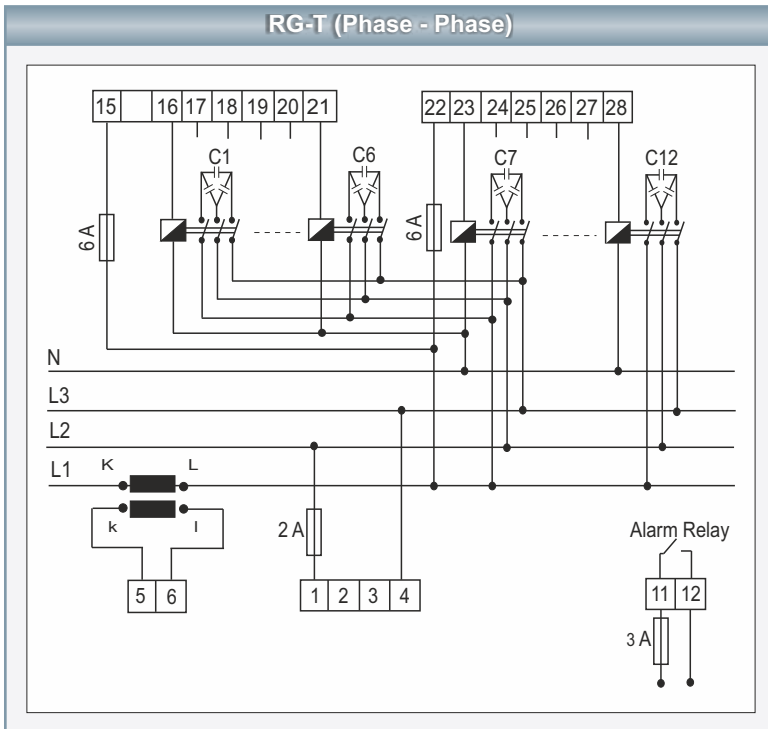
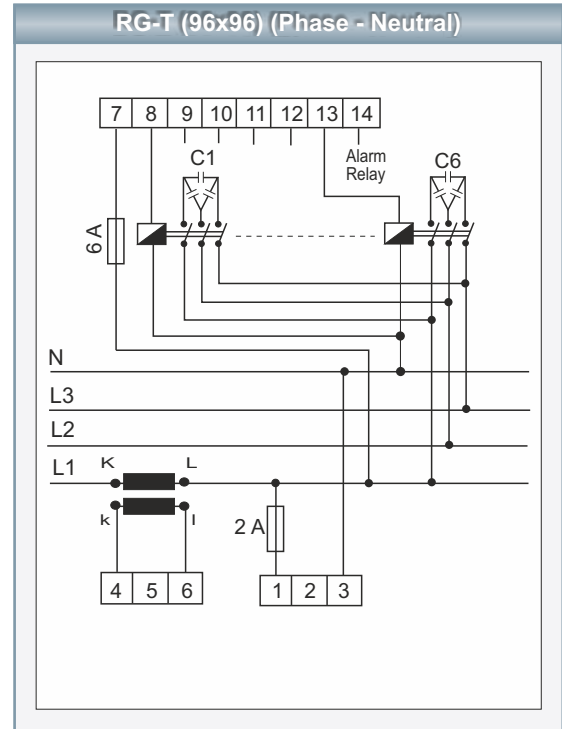
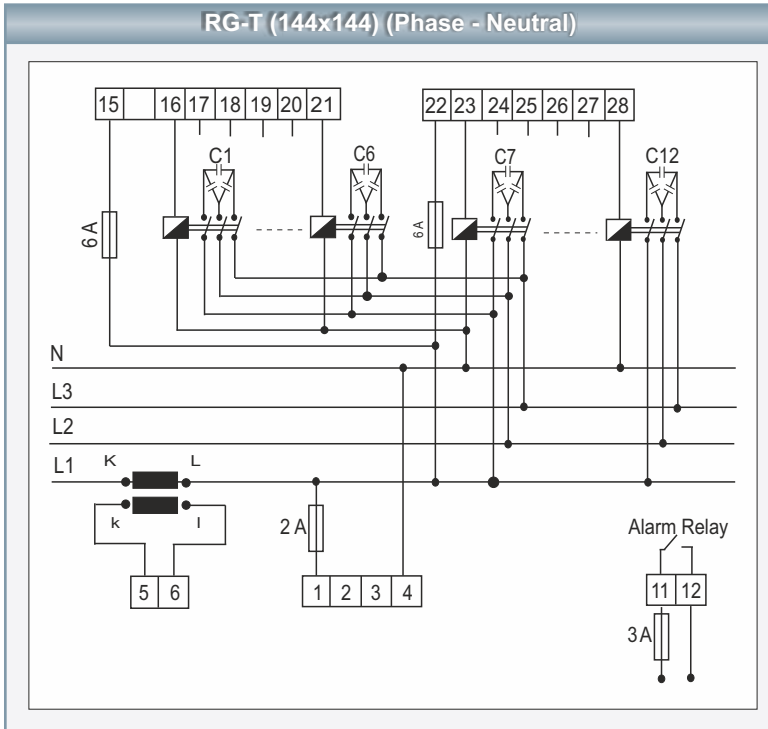

Power Factor Correction

Power Factor Controllers

RG / RG3 Series

Connection Diagrams

RG3-15CLS

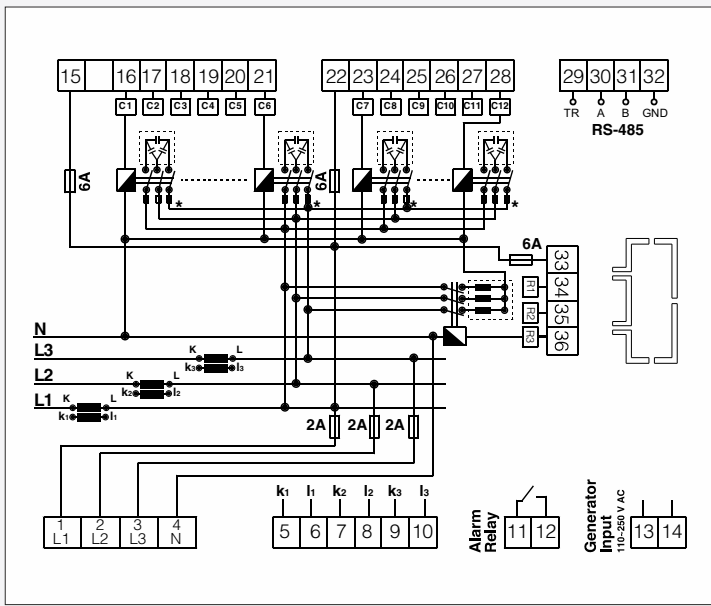

RG8-BS (96x96)

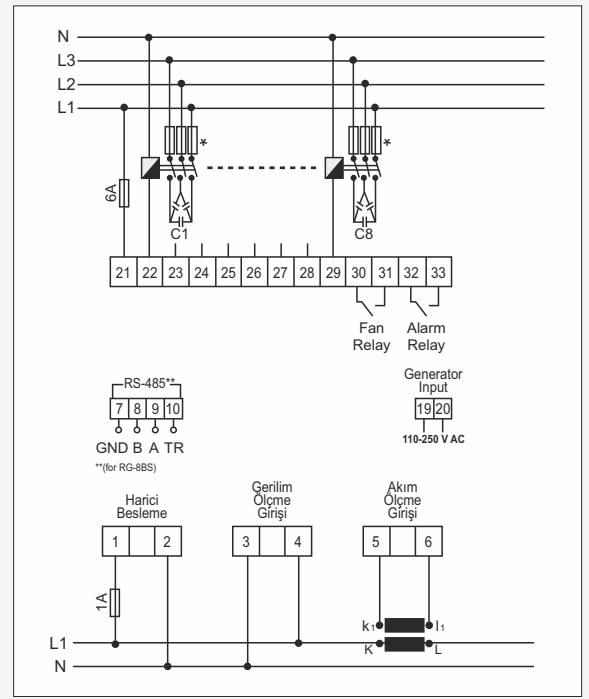

RG3-12CS

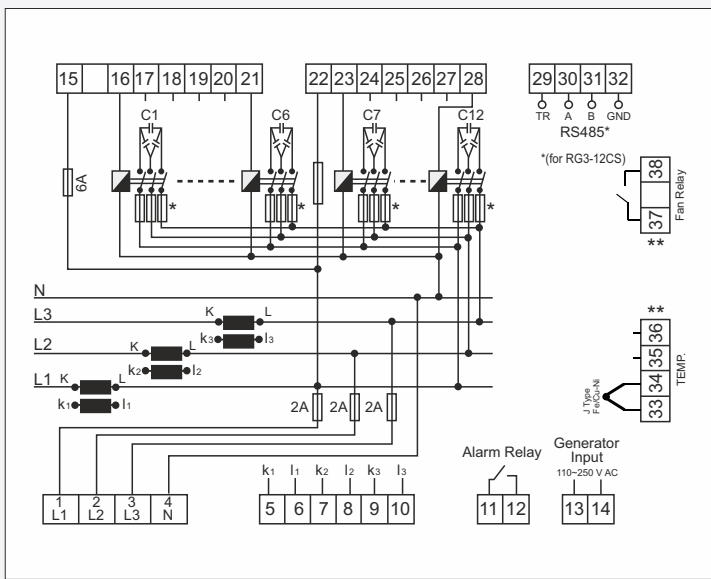

* Current value of 3-Fuses, which are connected to protect the capacitors, is chosen according to the nominal current value of capacitors.

Dimensions

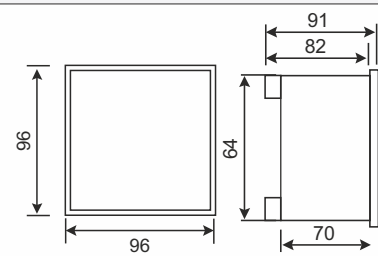

TYPE PR 19

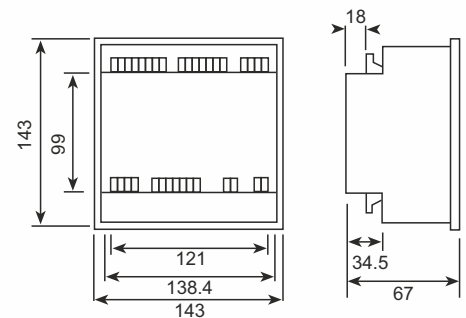

TYPE PR 16

** Optional