

SCORA-ER 14Pro



User Manual

Catalog # 200035 Rev. C

intelitek ▶▶

Copyright © 2011, Intelitek Inc.

SCORA-ER 14Pro

Catalog # 200035 Rev. C

March 2011 Reprinted/PDF version

Every effort has been made to make this book as complete and accurate as possible. However, no warranty of suitability, purpose, or fitness is made or implied. Intelitek is not liable or responsible to any person or entity for loss or damage in connection with or stemming from the use of the software, hardware and/or the information contained in this publication.

Intelitek bears no responsibility for errors which may appear in this publication and retains the right to make changes to the software, hardware and manual without prior notice.

INTELITEK INC.

444 East Industrial Park Drive

Manchester NH 03109-537

Tel: (603) 625-8600

Fax: (603) 625-2137

website: www.Intelitek.com

Safety

The SCORA-ER 14Pro is a potentially dangerous machine. Safety during operation is of the utmost importance. Use extreme caution when working with the robot.

Precautions

The following chapters of this manual provide complete details for proper installation and operation of the SCORA-ER 14Pro. The list below summarizes the most important safety measures.

1. Define a safety area as detailed on Figure 3-1.
2. Make sure the robot base is properly and securely bolted in place.
3. Make sure the cable from the body to the base can move freely during all movements of the robot's base axis.
4. Make sure both the encoder cable and the robot power cable are properly connected to the controller before it is turned on.
5. Make sure the robot arm has ample space in which to operate freely.
6. Make sure a guardrail or rope has been set up around the SCORA-ER 14Pro operating area to protect both the operator and bystanders.
7. If the distance between the robot and the Controller is greater than 1.5m, ensure that an **EMERGENCY** button is easily accessible, either with an external **EMERGENCY** button, or from the Teach Pendant.
8. Do not enter the robot's safety range or touch the robot when the system is in operation.
9. Press the controller's **EMERGENCY** button before you enter the robot's operating area.
10. Turn off the controller's **POWER** switch before you connect any inputs or outputs to the controller.

☞ *To immediately abort all running programs and stop all axes of motion, do one of the following:*

- Press the red **EMERGENCY** button on the controller.
- Press the **EMERGENCY** button on the Teach Pendant.



Warnings

1. Do not operate the SCORA-ER 14Pro until you have thoroughly studied this User Manual and the Controller USB-Pro and Scorbase for ER 9Pro/ER 14Pro User Manuals. Be sure you follow the safety guidelines outlined for both the robot and the controller.
2. Do not install or operate the SCORA-ER 14Pro under any of the following conditions:
 - Where the ambient temperature drops below or exceeds the specified limits.
 - Where exposed to large amounts of dust, dirt, salt, iron powder, or similar substances.
 - Where subject to vibrations or shocks.
 - Where exposed to direct sunlight.
 - Where subject to chemical, oil or water splashes.
 - Where corrosive or flammable gas is present.
 - Where the power line contains voltage spikes, or near any equipment which generates large electrical noises.
3. Do not abuse the robot arm:
 - Do not operate the robot arm if the encoder cable is not connected to the controller.
 - Do not overload the robot arm. The combined weight of the workload and gripper may not exceed 2kg (4.4 lb). It is recommended that the workload be grasped at its center of gravity.
 - Do not use physical force to move or stop any part of the robot arm.
 - Do not drive the robot arm into any object or physical obstacle.
 - Do not leave a loaded arm extended for more than a few minutes.
 - Do not leave any of the axes under mechanical strain for any length of time. Especially, do not leave the gripper grasping an object indefinitely.

☞ ***The robot is dangerous and can cause severe injury. Use with extreme caution.***

☞ ***Set up a protective screen or guardrail around the robot to keep people away from its working range.***

Table of Contents

Safety	iii
Precautions.....	iii
Warnings.....	iv
1	1-1
Unpacking and Handling	1-1
Unpacking and Handling the Robot	1-1
Repacking for Shipment	1-1
Acceptance Inspection	1-2
2	2-1
Specifications.....	2-1
Structure.....	2-2
Work Envelope	2-3
3	3-1
Installation	3-1
Preparations	3-1
SCORA-ER 14Pro Installation	3-2
Peripheral installation	3-6
Gripper Installation.....	3-6
4	4-1
Operating Methods	4-1
Software.....	4-1
Teach Pendant.....	4-1
5	5-1
Drive System	5-1
Axes 1 and 2	5-2
Axis 3.....	5-3
Axis 4.....	5-3
Motors.....	5-4
Harmonic Drive Gear	5-7
Pulleys and Timing Belt	5-9
Ball Bearing Screw	5-9
Worm Gear	5-11
Ball Bearing Spline.....	5-12
Axis Gear Ratios.....	5-12
6	6-1
Position and Limit Devices.....	6-1
Encoders	6-1
End of Travel (Limit) Switches	6-4
Hard Stops	6-6
Home Switches	6-6
7	7-1
Wiring.....	7-1
Robot Interface Cable	7-2
8	8-1
Maintenance.....	8-1

Daily Operation	8-1
Periodic Inspection	8-1
Troubleshooting.....	8-2

1

Unpacking and Handling

This chapter contains important instructions for unpacking and inspecting the SCORA-ER 14Pro robot arm.

☞ *Read this chapter carefully before you unpack the SCORA-ER 14Pro robot and controller.*

Unpacking and Handling the Robot

The robot is packed in expanded foam.

Save the original packing materials and shipping carton. You may need them later for shipment or for storage of the robot.

The robot arm weighs 45 kilos (100 pounds). Two people are needed in order to lift or move it.

Lift and carry the robot arm by grasping its column and/or base.
Do not lift or carry the robot arm by its horizontal links.

Repacking for Shipment

Be sure all parts are back in place before packing the robot.

The robot should be repacked in its original packaging for transport.

If the original carton is not available, wrap the robot in plastic or heavy paper. Put the wrapped robot in a strong cardboard box at least 15cm (about 6 inches) longer in all three dimensions than the robot. Fill the box equally around the unit with resilient packing material (shredded paper, bubble pack, expanded foam chunks).

Seal the carton with sealing or strapping tape. Do not use cellophane or masking tape.

Acceptance Inspection

After removing the robot arm from the shipping carton, examine it for signs of shipping damage. If any damage is evident, do not install or operate the robot. Notify your freight carrier and begin appropriate claims procedures.

The following items are standard components in the SCORA-ER 14Pro package. Make sure you have received all the items listed on the shipment's packing list. If anything is missing, contact your supplier.

Table 1: SCORA-ER 14Pro Items

Item	Description
SCORA-ER 14Pro Robot Arm	Includes: Cabling with air hoses; Hardware for mounting robot: 4 M8x60 bolts; 4 M8 washers; 4 M8 nuts.
Gripper (Optional): 2 options	Pneumatic Gripper includes: Pneumatic solenoid valve; Hardware for mounting gripper: 4 4M4x10 screws.
	Electric DC Servo Gripper with encoder includes: Hardware for mounting gripper: 4 4Mx10 screws.
Controller USB-Pro	Includes: Power Cable; USB Cable; Teach Pedant (TP) By-Pass Plug (required when TP not connected) (Preinstalled on the Controller); External Emergency By-Pass Plug (Preinstalled on the Controller).
Teach Pendant (Optional):	Includes: Mounting fixture; Teach Pedant – USB-Pro controller cable; Teach Pendant for Controller USB and USB-Pro User Manual
Software	Robotic software for Controller USB-Pro
Documentation	Controller USB-Pro User Manual
	Robocell for ER 9Pro/ER 14Pro User Manual
	Scorbase for ER 9Pro/ER 14Pro User Manual
	SCORA-ER 14Pro User Manual

2

Specifications

The following table gives the specifications of the SCORA-ER 14Pro robot arm.

Table 2: Specifications

Robot Arm Specifications		
Mechanical Structure	Horizontal articulated (SCARA)	
Arm Length		
Link 1	270mm (10.6")	
Link 2	230mm (9.0")	
Axis Movement	Axis Range	Effective Speed
Axis 1: Rotation	301.5°	87°/sec
Axis 2: Rotation	230.5°	118°/sec
Axis 3: Translation	198mm	152 mm/sec
Axis 4: Roll; without gripper cable: or Roll; with gripper cable:	unrestricted ±527°	265°/sec
Links 1 and 2 combined	1.5m/sec	
Maximum Operating Radius	Minimum 250 mm (9.84") Maximum 500 mm (19.69")	
End Effector	Pneumatic Gripper Electric DC servo Gripper	
Homing	Optical switch and encoder index pulse on each axis	
Feedback	Incremental optical encoders with index pulse on each axis	
Actuators	24VDC servo motor on each axis	
Transmission	Harmonic Drive gears, belt and lead screw	
Maximum Payload (Including gripper)	3kg (6.6 lb.) (with reduced acceleration) 2 kg (4.4 lb.)	
Position Repeatability	±0.05mm (±0.002")	
Weight	45 kg (100 lb.)	
Ambient Operating Temperature	2° - 40°C (36° - 104°F)	

Structure

The SCORA-ER 14Pro is a horizontal articulated (SCARA) robot.

The first two joints are revolute and determine the position of the end effector in the XY plane. The third joint is prismatic and determines the height (Z coordinate) of the end effector .

Figure 2-1 identifies the joints and links of the mechanical arm. Each joint is driven by a servo DC motor via a Harmonic Drive gear transmission.

The following table describes the movement of the axes:

Table 3: Joint Movements

Axis No.	Motion
1	Rotates Link 1 in horizontal (XY) plane
2	Rotates Link 2 in horizontal (XY) plane
3	Translates (raises and lowers) the end effector along Z axis
4	Rotates the end effector

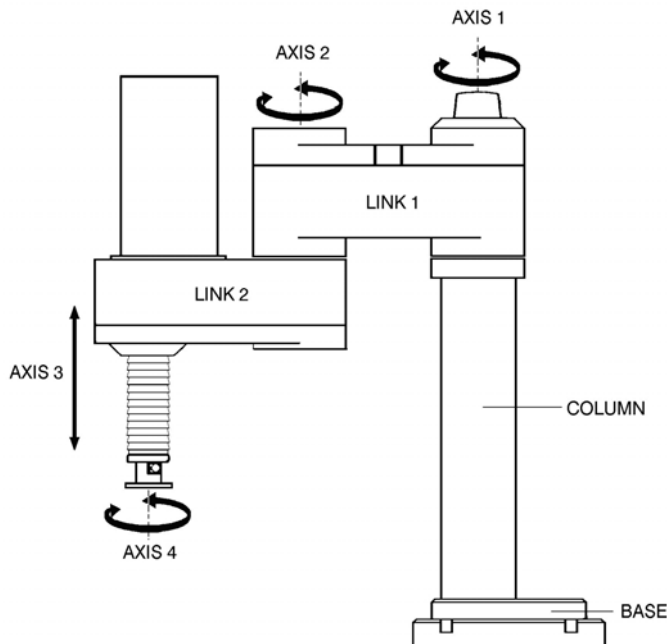

Figure 2-1: SCORA-ER 14Pro Mechanical Arm

Work Envelope

The length of the links and the degree of rotation of the joints determine the robot's work envelope. Figure 2-2 and Figure 2-3 show the dimensions of the SCORA-ER 14Pro, while Figure 2-4 gives a top view of the robot's work envelope.

The base of the robot is normally fixed to a stationary work surface.

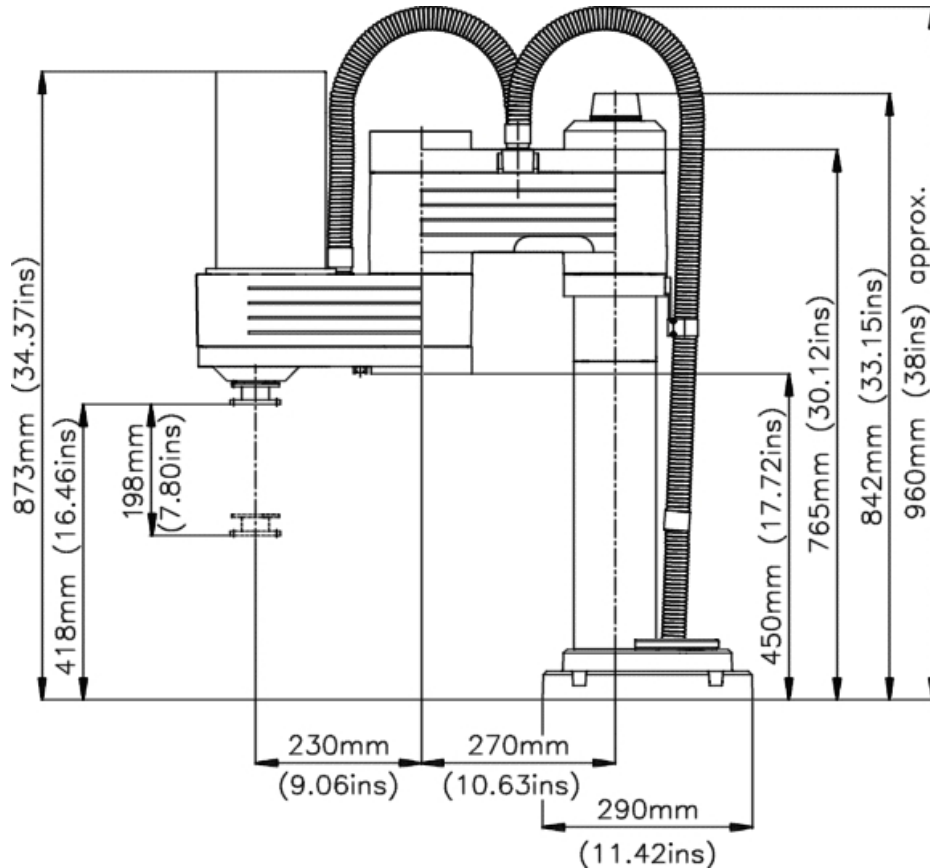

Figure 2-2: Dimensions (Side View)

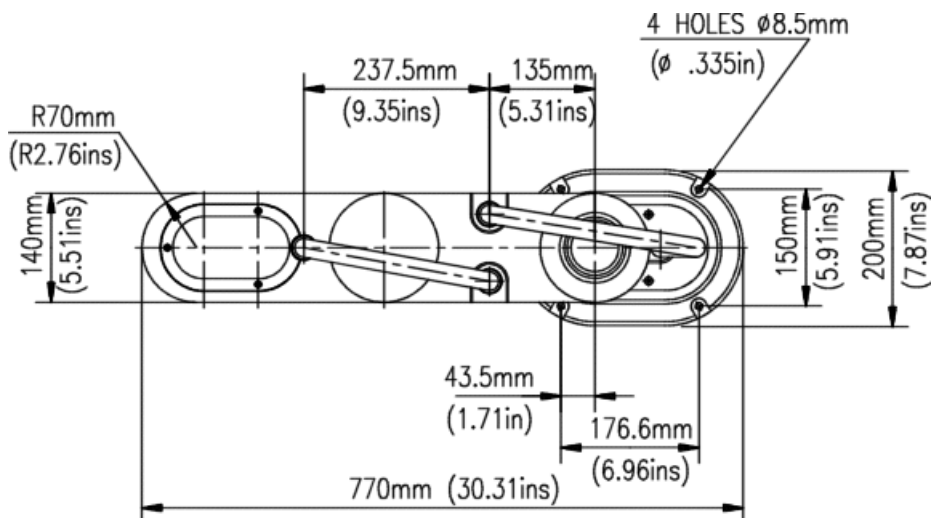

Figure 2-3: Dimensions (Top View)

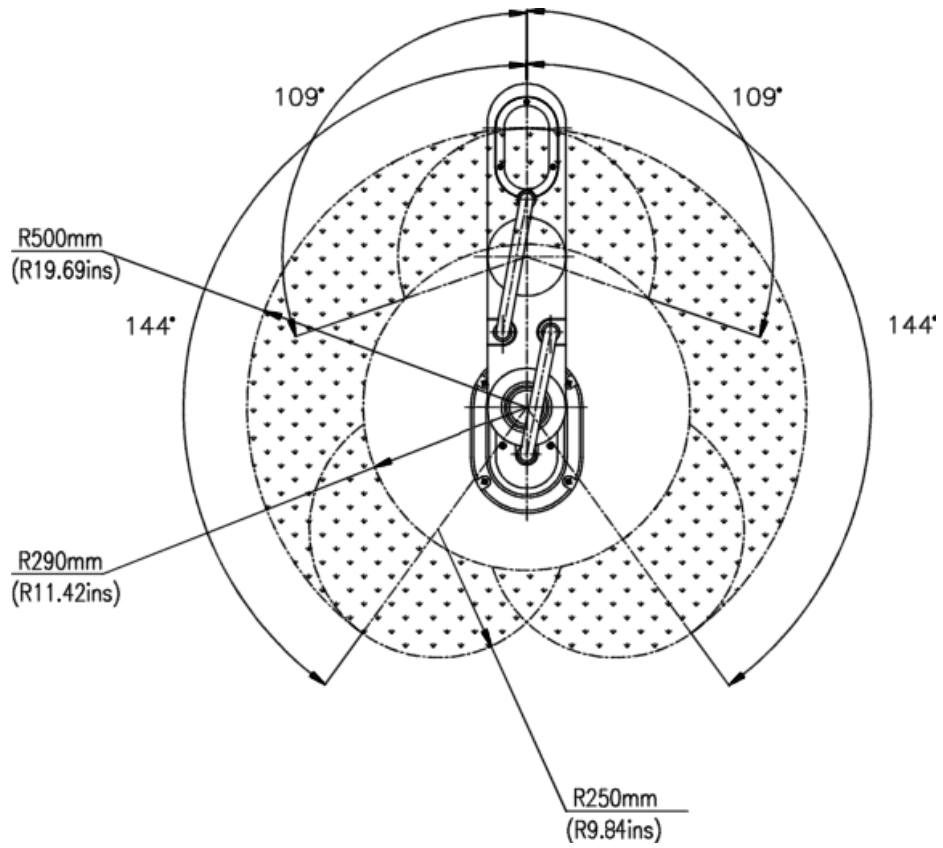

Figure 2-4: Working Range (Top View)

3

Installation

Preparations

Before you make any cable connections, set up the system components according to the following Preparation instructions.

Controller and Computer/Terminal Setup

Place the controller and computer at a safe distance from the robot, well outside the robot's safety range.

Make sure the setup complies with the guidelines defined in the Safety guidelines in the Controller USB-Pro User Manual.

Robot Setup

Refer to Figure 3-1 and Figure 3-2.

1. Set up the SCORA-ER 14Pro on a sturdy surface with at least 70cm of free space all around the robot.

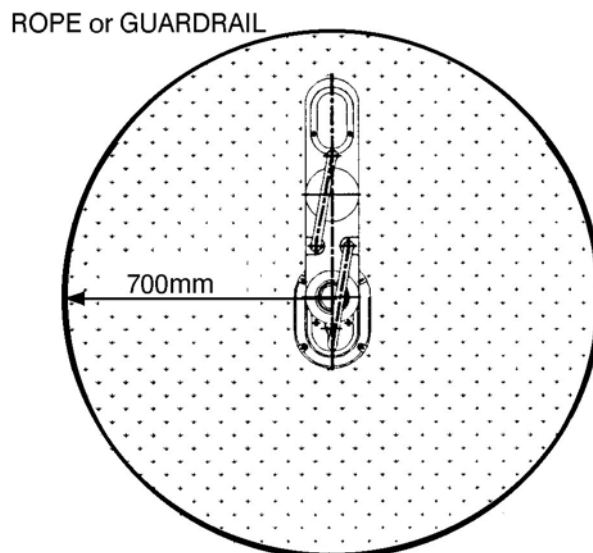

Figure 3-1: Robot Safety Range

2. Set up the robot so that it faces in the proper direction towards the application or machine it will serve.
3. Fasten the base of the robot to the work surface with four sets of bolt, washer and nut.

Make sure the robot is securely bolted in place. Otherwise the robot will become unstable and topple over while in motion.

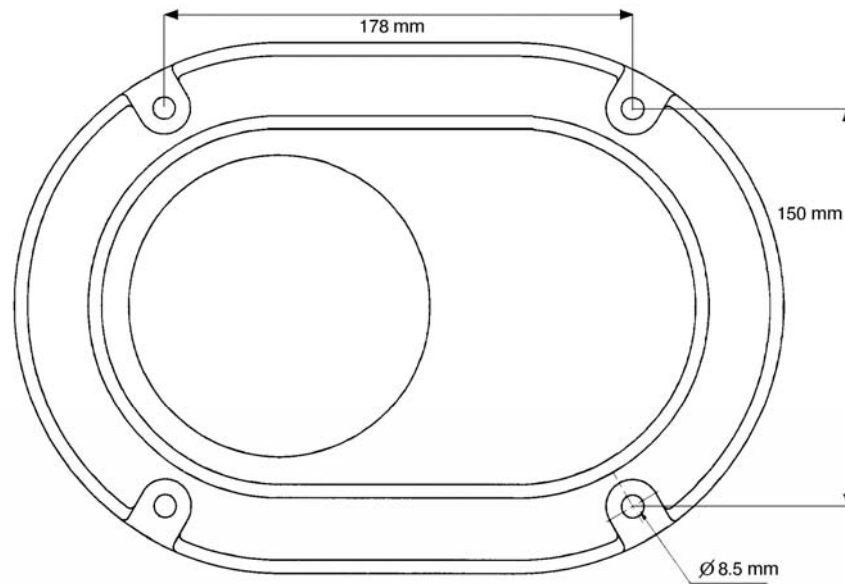

Figure 3-2: Robot Base Layout

4. Set up a guardrail or rope around the SCORA-ER 14Pro operating area to protect both the operator and bystanders.

SCORA-ER 14Pro Installation

Controller Installation

Perform the necessary installation and configuration procedures detailed in the Controller USB-Pro User Manual.

Robot Installation

☞ *Before you begin, make sure the controller POWER switch is turned off.*

Refer to Figure 3-3. Refer also to the wiring information and diagram in Chapter 7.

1. Connect the safety ground wires:
 - Unscrew and remove the nuts and washers from the safety ground studs on the controller connector panel.
 - Connect the green/yellow wires from both the robot power cable and the encoders cable to the safety ground studs on the controller connector panel.
 - After you have placed the ground wire terminals onto the stud, replace and tighten the washer and nut.

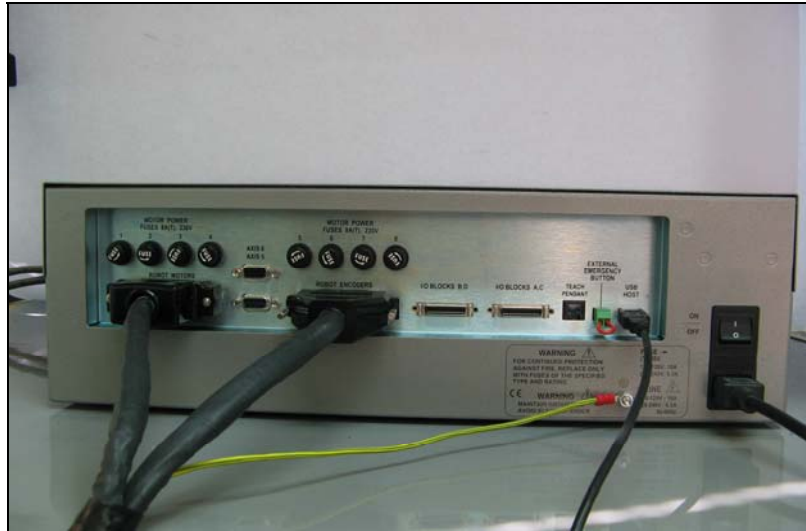
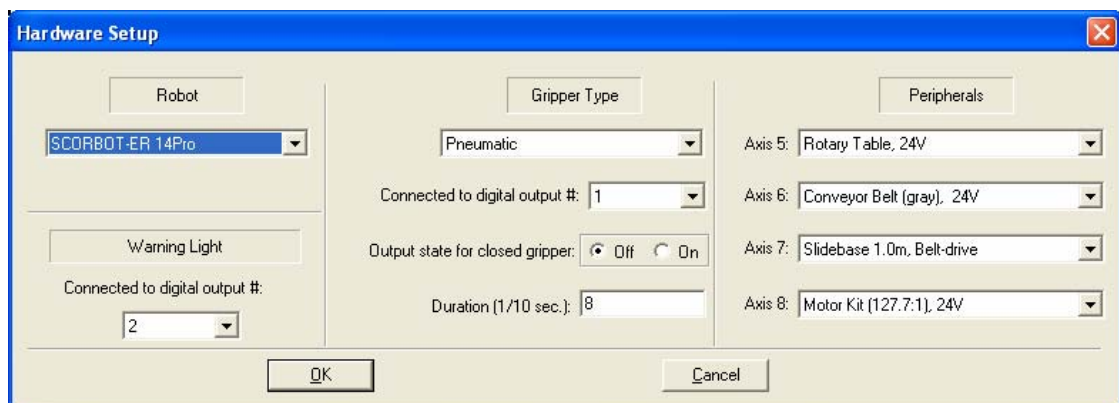

Figure 3-3: Robot Controller-Back

2. Connect the two cables which connect the robot and the controller.
 - Plug the D37 connectors on the encoder cable into the Robot Encoders port on the controller connector panel. Tighten the retaining screws on the connector.
 - Plug the 50-pin connector on the robot cable into the Robot Motors port on the controller.
3. Connect the robot warning light to the controller:
 Connect the red and black wires to any unused relay output terminal: one wire to NO and one wire to C on the same output.

Hardware check

- ☞ Check that all the wires are correctly installed. See Figure 3-3.
- ☞ Before working with the Robot, it **must** be configured in Scorbaser. Select **Options / Hardware Setup** and configure the Robot being used. For more information refer to the Hardware Setup section in the Scorbaser for ER 9Pro/ER 14Pro User Manual.



Hardware Setup in Scorbaser

Having installed the software and hardware, it is necessary to perform a check to see that the hardware is working correctly. This is performed as follows:

1. Turn on the controller. Turn on the computer. Start Scorbace.
2. Select **Options | On Line**, decline the option to turn control on.
3. Select **View | Dialog Bars | Encoder Counts**.
4. Manually move each axis separately while watching the **Encoder Counts** window. As each axis is moved, the numbers pertaining to it should change. Should all the numbers change for all of the axes, this indicates that the robot is functioning and communicating with the controller.
5. Press **F5** to turn control on.

Select **View | Manual Movement**. Control each axis with the relevant buttons. Watch the **Encoder Counts** window to see that it is responding correctly.

- ☞ *It is important to make sure that one has the **EMERGENCY** stop button on the controller within easy reach as the SCORA-ER 14Pro could behave unexpectedly.*

Homing the Robot

After you have completed the robot installation, execute the robot's Home routine, as described below.

- ☞ *The robot must be homed before you mount the gripper.*

Before you begin the homing procedure, make sure the robot has ample space in which to move freely and extend its arm.

1. Turn on the controller. Turn on the computer. Start Scorbace.
2. Select **Run | Search home - all axes**.

OR

click the **Search Home**  icon.

A window opens displaying the number of the axis currently being homed. Each time an axis is successfully homed, a checkmark appears next to the axis number. After the four axes and the gripper have been homed, a checkmark appears next to Robot.



Homing Status Window

To abort homing while the procedure is still in progress, do one of the following:

- Press [F9] (Stop command)
- Press the red **EMERGENCY** button on the controller.
- Press the **EMERGENCY** button on the Teach Pendant.

If the homing procedure fails, a message appears.

The **Search Home - All Axes** command executes the robot's homing procedure as well as that of any peripheral devices that have been configured in the **Options | Hardware Setup** menu. The command is available only when Scorbase is On-line for the first time.

If the system has already been homed and you change Scorbase to Off-line mode, there is no need to home the system again when you return to On-line mode.

When Scorbase is in Off-Line Mode, or when Scorbase is installed, the homing procedure is not required, although it can be executed.

Peripheral installation

For all peripherals, once they have been physically installed they must be added in Scorbase. Make sure USB-Pro controller servo control is off. The Motors state indicator on the front panel of the controller must be in Off state (unlit). Select **Options | Hardware Setup** and configure the peripheral that has been added. For more information refer to the *Hardware Setup* section in the Scorbase for ER 9Pro/ER 14Pro User Manual.

Gripper Installation

The gripper is attached to the flange at the end of the robot arm whose layout is shown in Figure 3-4.

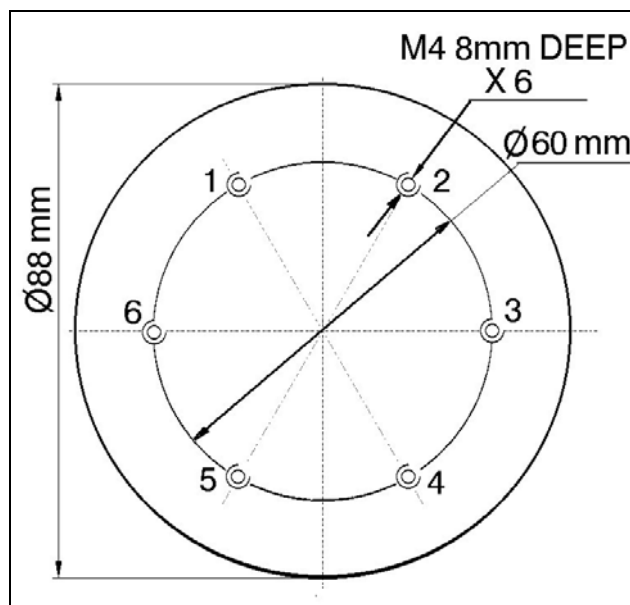

Figure 3-4: Gripper Mounting Flange Layout

Pneumatic Gripper

The pneumatic gripper, shown in Figure 3-6, is controlled by a 5/2 solenoid pneumatic valve which is activated by one of the controller's relay outputs. The valve is 24VDC and can draw its power from the controller's User Power Supply.

☞ *The robot must be homed before you mount the gripper.*

1. Using a 3mm hex wrench and four M4x8 socket screws, attach the gripper to the robot arm flange.
2. Connect the coiled double hose from the gripper to the quick coupling on the underside of Link 2, as indicated in Figure 3-5.

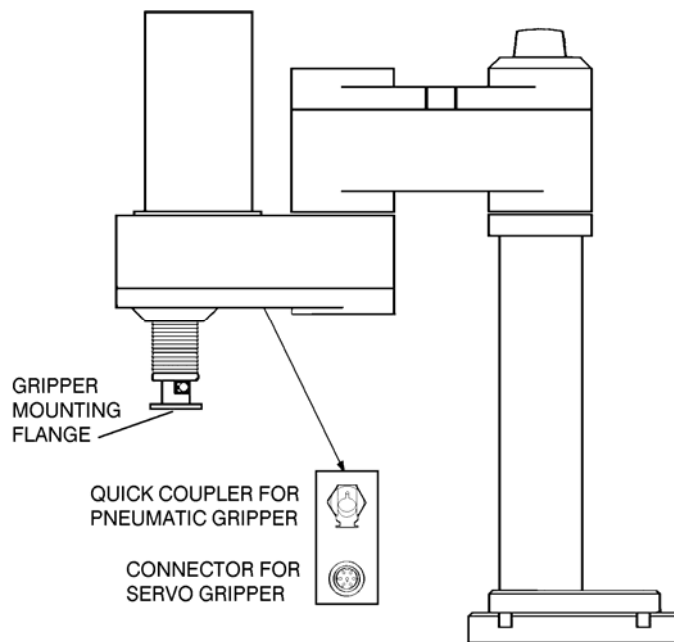

Figure 3-5: Gripper Connectors



Figure 3-6: Pneumatic Gripper

3. Refer to Figure 3-9.
 - Connect the two transparent 1/4" O.D. hoses from the robot to the CYL ports on the pneumatic valve.
 - Connect a 5 bar/90 PSI air supply to the IN port on the valve.

4. Refer to Figure 3-8.

Connect the valve to the controller's User Power Supply as follows:

- Connect the black wire to a common terminal.
 - Connect the red wire to the normally open (NO) terminal of any unused relay output.
5. Connect 24VDC to the common (C) terminal of the **same** relay output, as shown in Figure 3-8.

Attach the valve to the controller or any other metallic surface by means of the valve's magnetic base.



Figure 3-7: Pneumatic gripper valve connection example (front connection)

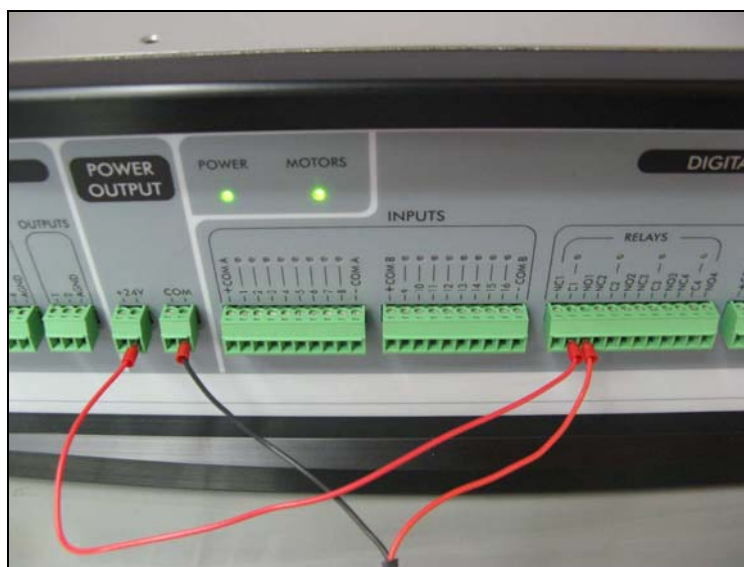

Figure 3-8: Example of gripper connection

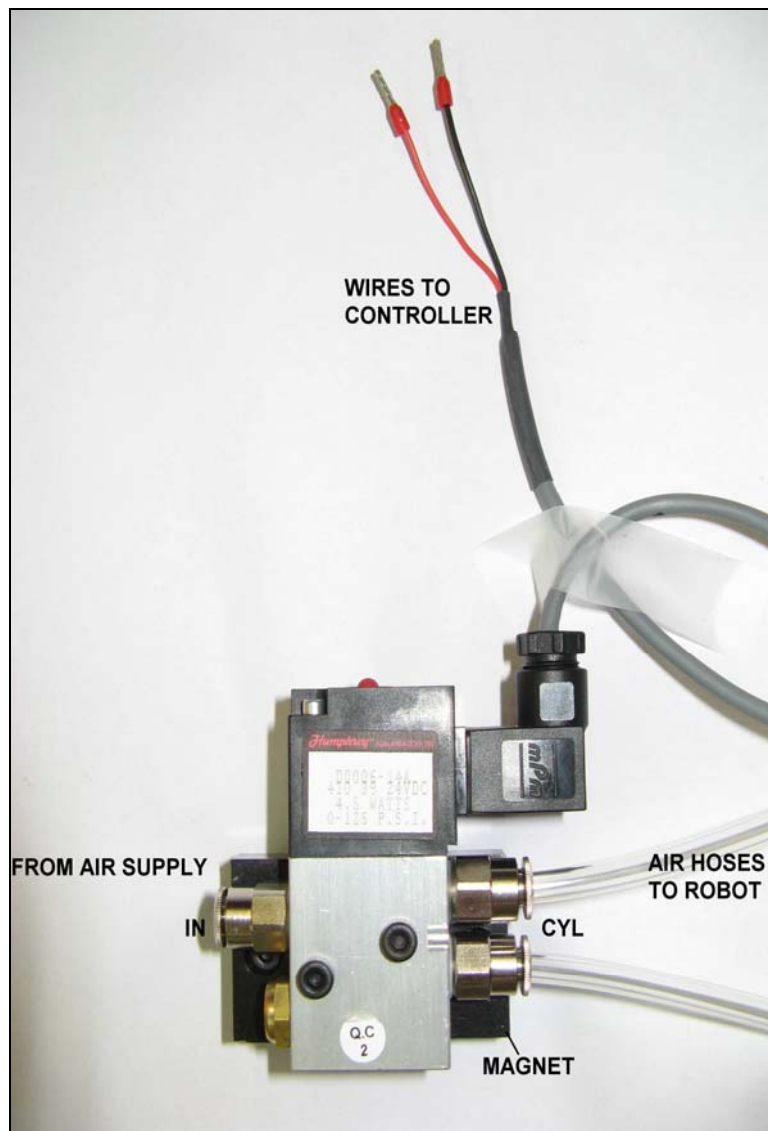

Figure 3-9: Pneumatic Solenoid Valve

DC Servo Gripper

☞ *The robot must be homed before you mount the gripper.*

1. Using a 3 mm hex wrench and four M4x10 socket screws, attach the gripper to the gripper mounting flange at the end of the robot arm.
2. Connect the gripper cable to the electrical connector on the robot arm.

Make sure the connector is oriented correctly.

3. Carefully execute the robot **HOME** command. Stay close to the teach pendant or controller. If the gripper cable becomes entangled or excessively stretched during the homing, abort the procedure immediately.
4. The gripper has a rotation of $\pm 270^\circ$. Do not attempt to move the gripper beyond this limit.
5. At the end of each work session (before turning off the controller) return the robot to home position. This is in order to prevent tangling of the wires upon its next use. To Home the Robot, Select **Run | Go Home - All Axes**.

☞ *Axis 5 is reserved by default controller configuration for a servo gripper. To connect a different device as axis 5, you must change the system configuration by means of the Hardware Setup that is found under Options on the Menu Bar. Refer to the Scorbase for ER 9Pro/ER 14Pro User Manual for more details.*

Activating the Gripper

Open and close the gripper in order to verify that it is functioning. To do so, select **View | Manual Movement**. Control the gripper using the manual movement window which appears. This window can be used for both the electric and the pneumatic gripper.

4

Operating Methods

The SCORA-ER 14Pro robot can be programmed and operated in two ways. The Scorbse for ER 9Pro/ER 14Pro User Manual includes instructions on operating the robot.

Software

Scorbse Software

Scorbse for ER 9Pro/ER 14Pro is a robot control software package which is supplied with the controller. Its menu-driven structure and off-line capabilities facilitate robotic programming and operation.

Scorbse runs on any PC system with Microsoft Windows XP/Vista/7, and communicates with the Controller through USB plug and play interface.

The Scorbse for ER 9Pro/ER 14Pro User Manual provides detailed descriptions and examples of the Scorbse commands.

Teach Pendant

The teach pendant is a hand-held terminal which is used for controlling the SCORA-ER 14Pro robot and peripheral equipment. The teach pendant is most practical for moving the axes, recording positions, and sending the axes to recorded positions. Other functions can also be executed from the teach pendant.

☞ *The Teach Pendant will only work if Scorbse is running on the PC, and is in On-line mode.*

The Teach Pendant for Controller USB-Pro User Manual fully describes the various elements and functions of the teach pendant.

5

Drive System

The SCORA-ER 14Pro utilizes several different mechanical transmissions for transferring motion from the motors to the joints.

The structure and operation of the various components used to drive the robot's axes are described in this chapter.

☞ *Note that the illustrations of components shown in this chapter are for descriptive purposes, and may not be the actual components used in the SCORA-ER 14Pro .*

Axes 1 and 2

The main components of the drive system for axes 1 and 2 are the motor, the coupling and the Harmonic Drive gear, as shown in Figure 5-1.

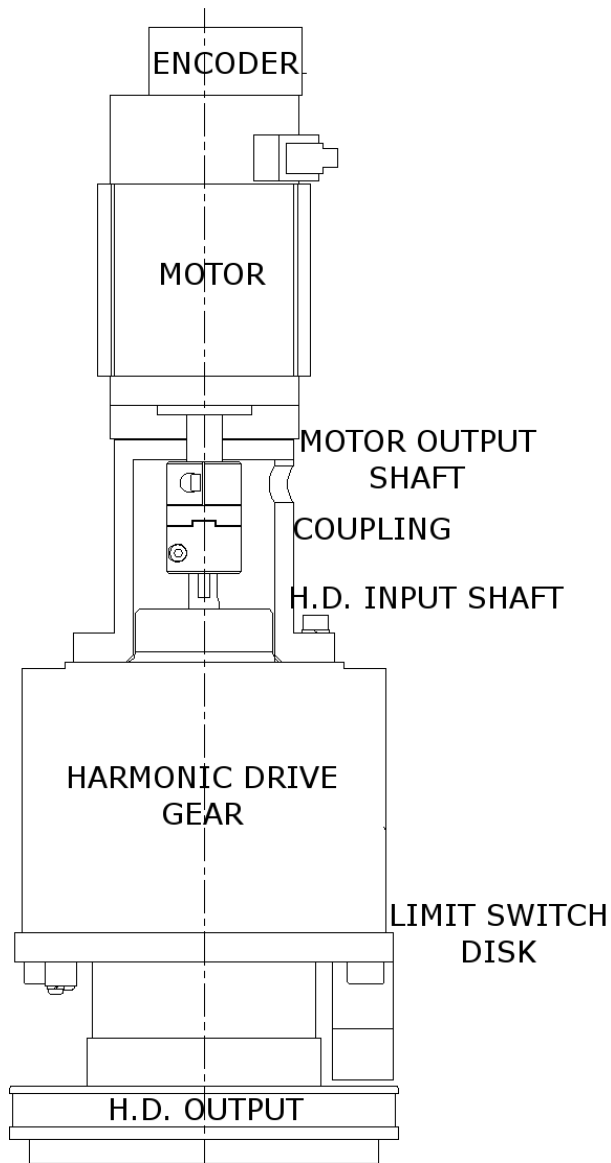

Figure 5-1: Drive Systems Axes 1 and 2

Axis 3

The drive system for axis3 produces the linear motion of the Z-axis. Its main components are the motor, pulleys and a timing belt, and a ball bearing lead screw with nut, as shown in Figure 5-2.

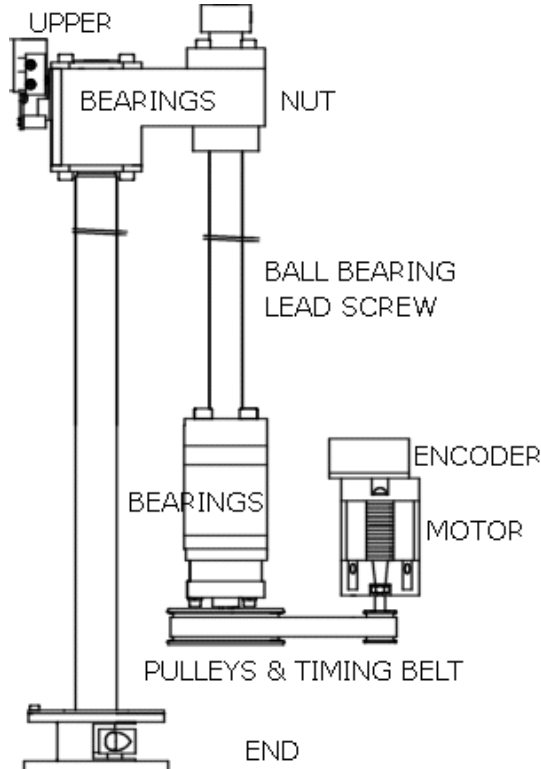

Figure 5-2: Drive System Axis 3

Axis 4

The drive system for axis4 (Z-roll) produces the rotation of the end effector flange. Its main components are the motor, a worm gear and a spline, as shown in Figure 5-3 .

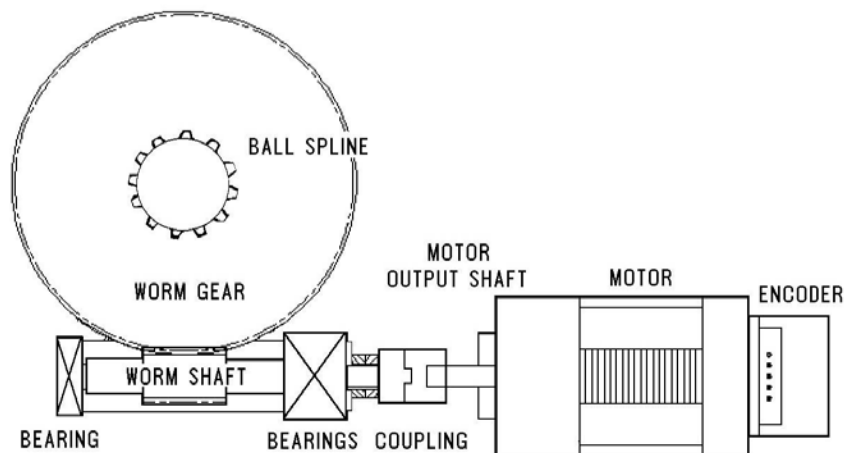

Figure 5-3: Drive System Axis 4

Motors

An electric motor is an actuator - a device which transforms electric power into mechanical power. The motor converts signals from the controller into rotations of its shaft.

A robot arm such as the SCORA-ER 14Pro imposes severe requirements on the actuators, such as the following:

- The robot motor must rotate at different speeds, and with a high degree of accuracy. For example, if the robot is to be used for a spray painting application, it must be able to accurately follow the defined path at the specified speed.
- The robot motor must allow fine speed regulation so that the robot will accelerate and decelerate as required by the application.
- The robot motor must supply large torques throughout its speed range and also when the joint is stationary.
- The robot motor must be able to stop extremely quickly without overshooting the target position, and perform rapid changes in direction.
- Since mounting motors on the robot arm adds to the robot's weight and inertia, the robot motors must be light and compact, yet powerful. As shown in Figure 5-4, the motors of the SCORA-ER 14Pro are located close to the axes they drive.

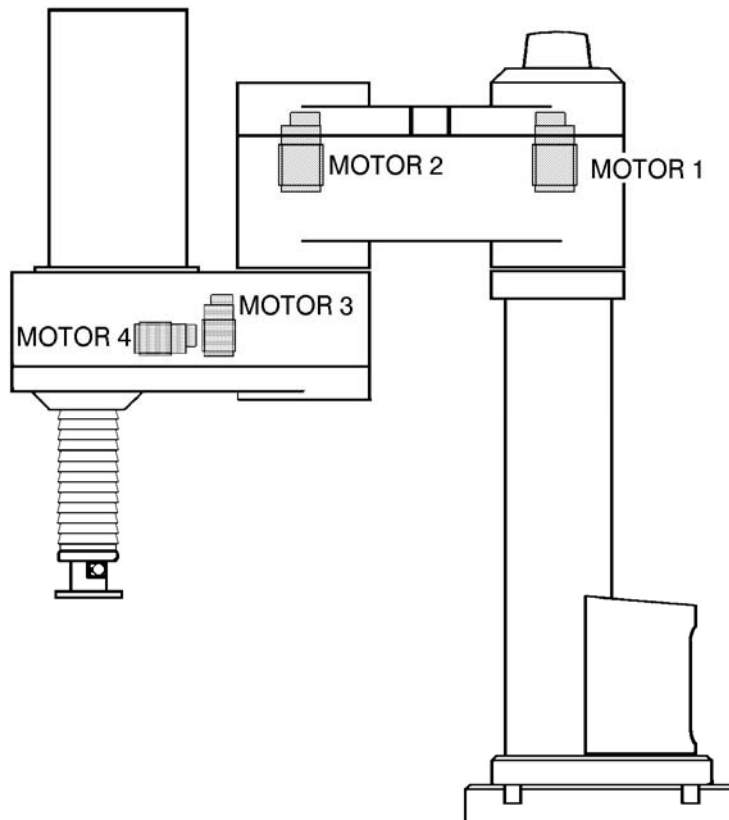

Figure 5-4: Motor Locations in SCORA-ER 14Pro

DC Motor Structure

The principles of operation of electrical motors in general, and DC motors in particular, are based on an electrical current flowing through a conductor situated within a magnetic field. This situation creates a force which acts on the conductor. Figure 5-5 shows the basic structure and components of a DC motor comparable to the structure of the motors used in the SCORA-ER 14Pro. This motor has three main components:

- **Stator:** This is a static component which creates the magnetic field. The stator may be a permanent magnet, or an electromagnet consisting of a coil wound around thin iron plates.
- **Rotor:** This is the component which rotates within the magnetic field. The external load is connected to the rotor shaft. The rotor is generally composed of perforated iron plates, and a conducting wire is wound several times around the plates and through the perforations. The two ends of the conductor are connected to the two halves of the commutator, which are connected to the electric current via the brushes.
- **Brushes:** These connect the rotating commutator to the electric current source.

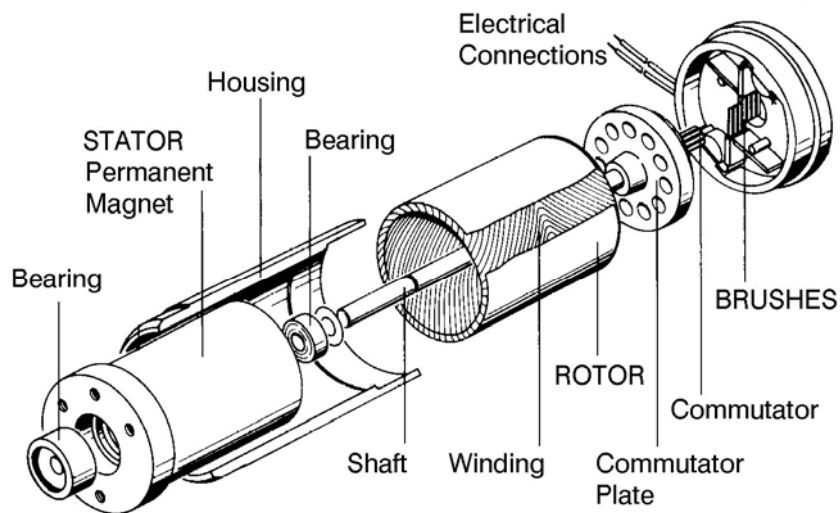

Figure 5-5: Basic Structure of a DC Motor

SCORA-ER 14Pro Motors

The SCORA-ER 14Pro uses permanent magnet DC motors to drive the axes.

Axes 1 and 2 of the SCORA-ER 14Pro are powered by the motor shown in Figure 5-6. Axes 3 and 4 are powered by the motor shown in Figure 5-7.

These motors are able to move at extremely high rates of revolution, to move loads with high torques, and (with encoder attached) to achieve a very high resolution.

Table 4: Motor Specifications

	Motor Axes 1 and 2	Motor Axes 3 and 4
Peak Rated Torque	143 oz.in	27.8 oz.in
Rated Torque	32 oz.in	12.5 oz.in
Maximum Operating Speed	4000rpm	4500rpm
Weight	1.29k / 2.84lb	0.28k / 0.62lb

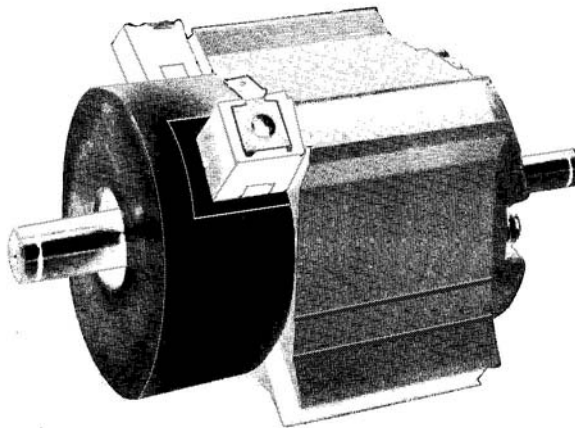

Figure 5-6: Motor on Axes 1 and 2

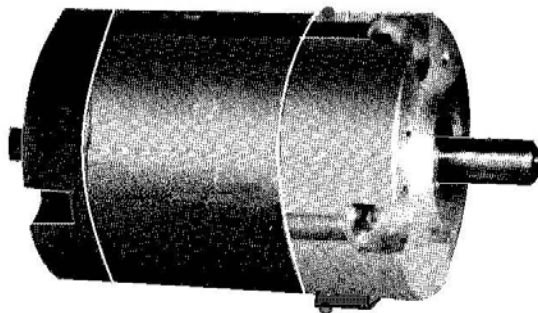

Figure 5-7: Motor on Axes 3 and 4

Harmonic Drive Gear

The Harmonic Drive transmission used in the SCORA-ER 14Pro, shown in Figure 5-8, offers a very high gear ratio.

The Harmonic Drive gears used in the SCORA-ER 14Pro have four main components:

- **Circular spline:**
a solid steel ring, with internal gear teeth, usually fixed to the robot link.
- **Wave generator:**
a slightly elliptical rigid disk, which is connected to the input shaft, with a ball bearing mounted on the outer side of the disk.
- **Flexspline:**
a flexible, thin-walled cylinder, with external gear teeth, usually connected to the output shaft.
- **Dynamic spline:**
a solid steel cylinder, with internal gear teeth.

The external gear teeth on the flexspline are almost the same size as the internal gear teeth on the circular spline except there are two more teeth on the circular spline, and the teeth only mesh when the wave generator pushes the flexspline outwards.

Because the wave generator is elliptical, the flexspline is pushed out in two places. As the motor rotates the input shaft, the wave generator rotates and the location of meshing teeth rotates with it. However, because there are two less teeth on the flexspline, it has to rotate backwards slightly as the wave generator rotates forwards. For each complete rotation of the input shaft, the flexspline moves backwards by two teeth. Figure 5-9 and Figure 5-10 show the different steps in this process.

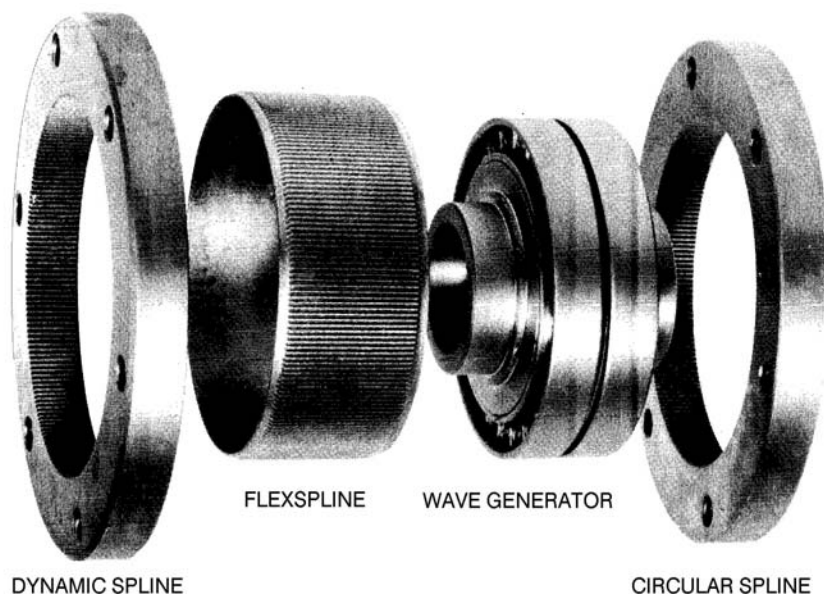

Figure 5-8: Harmonic Drive Structure

As in all gears, the gear ratio of the Harmonic Drive is the ratio of the input speed to the output speed. If the number of teeth on the flexspline is N_f , then for every revolution of the input shaft, the output shaft rotates by $2/N_f$ of a revolution (that is, two teeth out of N_f teeth). Hence:

$$\text{HD gear ratio} = \frac{1}{\left(\frac{2}{N_f}\right)} = \frac{N_f}{2}$$

The Harmonic Drive gear ratio for axis 1 and axis 2 of the SCORA-ER 14Pro is 160:1.

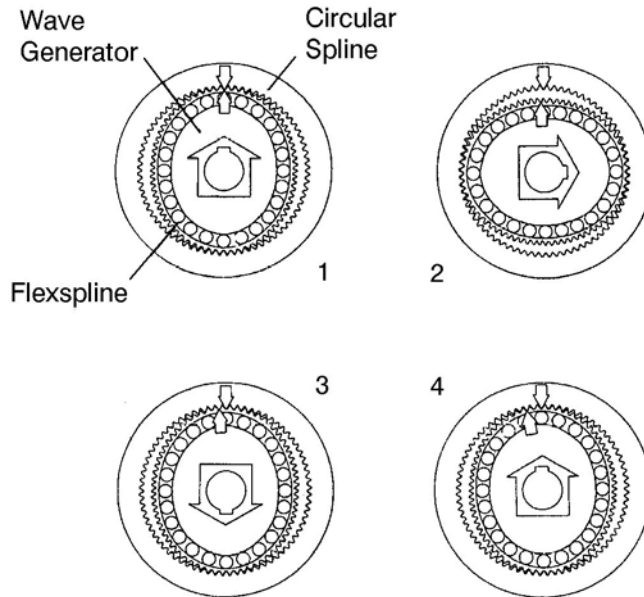

Figure 5-9: Operation of the Harmonic Drive

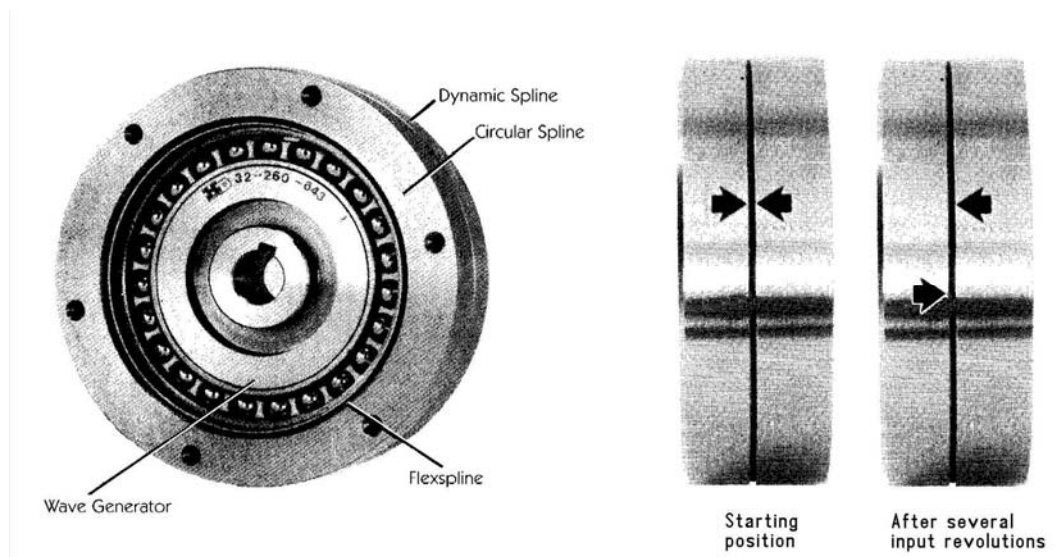

Figure 5-10: Operation of the Harmonic Drive

Pulleys and Timing Belt

The axis 3 transmission contains two pulleys and a timing belt, as illustrated in Figure 5-11. The input pulley is mounted on the motor output shaft and the output pulley is connected to the lead screw.

The gear ratio of the belt drive is the ratio of the output pulley to the input pulley, calculated according to the number of teeth on each pulley.

The belt drive used in the SCORA-ER 14Pro has a ratio of 80:21.

Thus, for each rotation (360°) of the input pulley, the output pulley moves 94° , or approximately one-quarter of a rotation.

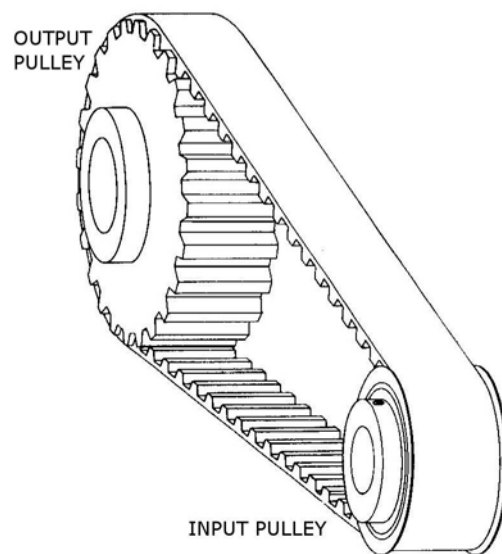

Figure 5-11: Pulleys and Timing Belt

Ball Bearing Screw

A ball bearing lead screw converts the rotation of the motor to the linear motion of the Z-axis.

In lead screw transmissions, the screw is rotated by the motor, and the shaft is connected to the nut, or sleeve, as illustrated in Figure 5-12. In the SCORA-ER 14Pro the screw rotates and the nut travels along the length of the screw.

As shown in Figure 5-13, a ball bearing screw thread is actually a hardened ball race. The nut consists of a series of bearing balls circulating in a similar race. The bearing balls are transferred from one end of the nut to the other by return tubes.

The low-friction ball-bearing lead screw provides more accurate and enduring performance.

The lead screw used in the SCORA-ER 14Pro has a 16mm lead. That is, for each rotation of the screw, the nut travels a linear distance of 16mm.

The lead screw of the SCORA-ER 14Pro is fitted with a brake which halts motion of the Z-axis when motor power is cut off.

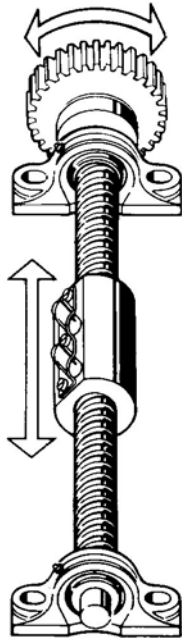

Figure 5-12: Lead Screw Transmission

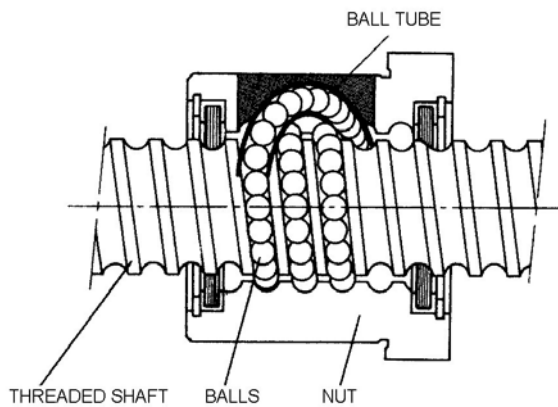

Figure 5-13: Ball Bearing Screw

Worm Gear

A worm gear transmission, shown in Figure 5-14, is used in the SCORA-ER 14Pro to transfer the rotation of motor 4 to the rotation of the Z-axis.

The ratio of a worm gear transmission is defined as:

$$\frac{\text{\# teeth on worm gear}}{\text{\# of starts on worm shaft}}$$

The worm gear used in the SCORA-ER 14Pro has 100 teeth and the shaft has two starts. Thus, the worm gear transmission has a ratio of 50:1.

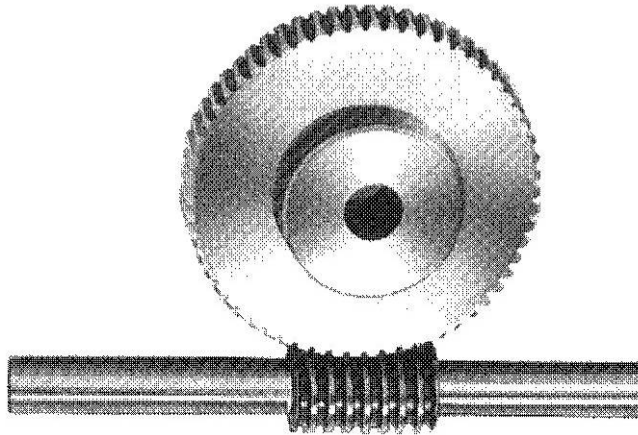

Figure 5-14: Worm Gear Transmission

Ball Bearing Spline

The SCORA-ER 14Pro uses a ball bearing spline, shown in Figure 5-15, to transmit torque from the worm gear to the Z-axis (slider) shaft, while allowing linear motion of the axis.

Ball bearing splines are similar to ball bearing screws in that they both employ the rolling contact principle of balls recirculating in a path between a shaft (spline) and a matching nut (sleeve). In a ball bearing spline, however, the path of the rolling balls is straight, rather than helical.

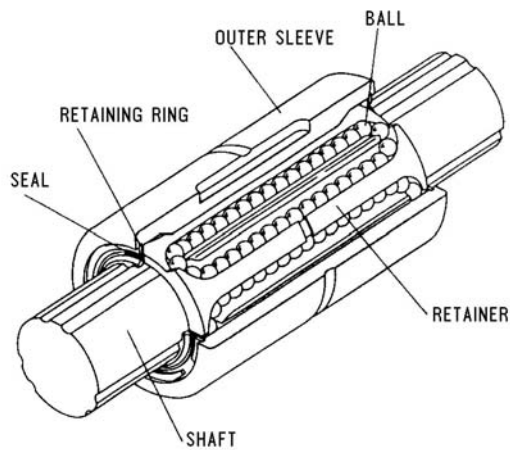

Figure 5-15: Ball Bearing Spline

Axis Gear Ratios

The overall gear ratio of the output shaft which moves the axis is the product of the ratios of the transmissions in each drive.

Axes 1 and 2 are driven by Harmonic Drive gears with a gear ratio of 160:1. Thus, one rotation (360°) of the output shaft of motor 1 or 2 moves the axis 2.25° .

Axis 3 is driven by a belt drive with a ratio of 80:21, and a lead screw which converts each rotation of the output pulley to a linear movement of 16mm. Thus, for each rotation (360°) of motor 3 output shaft, the Z-axis will move a linear distance of 4.2mm.

Axis 4 is driven by a worm gear with a ratio of 50:1. Thus, one rotation (360°) of motor 4 output shaft causes the end effector flange to rotate 7.2° .

6

Position and Limit Devices

This chapter describes the various elements in the SCORA-ER 14Pro which play a part in the positioning of the robot arm and the limiting of its motion.

- Encoders
- End of Travel Switches
- Hard Stops
- Home Switches

☞ *Note that the illustrations of components shown in this chapter are for descriptive purposes, and may not be the actual components used in the SCORA-ER 14Pro.*

Encoders

The location and movement of an axis is commonly measured by an electro-optical encoder attached to the motor which drives the axis. The encoder translates the rotary motion of the motor shaft into a digital signal understood by the controller.

Figure 6-1 shows the encoder mounted on a SCORA-ER 14Pro motor.

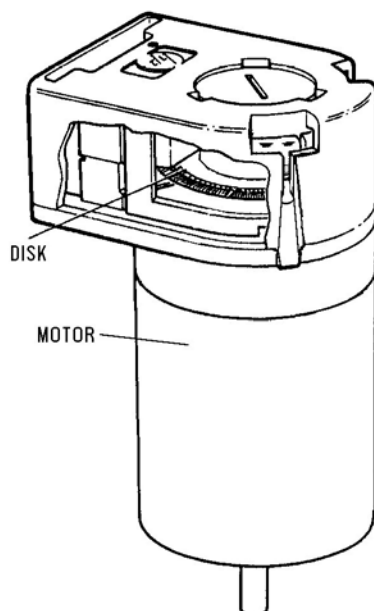

Figure 6-1: SCORA-ER 14Pro Encoder

The encoder used on the SCORA-ER 14Pro contains a single light emitting diode (LED) as its light source. Opposite the LED is a light detector integrated circuit. This IC contains several sets of photodetectors and the circuitry for producing a digital signal. A perforated, rotating disk is located between the emitter and detector IC. As the encoder disk rotates between the emitter and detectors, the light beam is interrupted by the pattern of bars and windows on the disk, resulting in a series of pulses received by the detectors.

The SCORA-ER 14Pro encoders have 512 slots, as shown in Figure 6-2. An additional slot on the encoder disk is used to generate an index pulse (C-pulse) once for each full rotation of the disk. This index pulse serves to determine the home position of the axis.

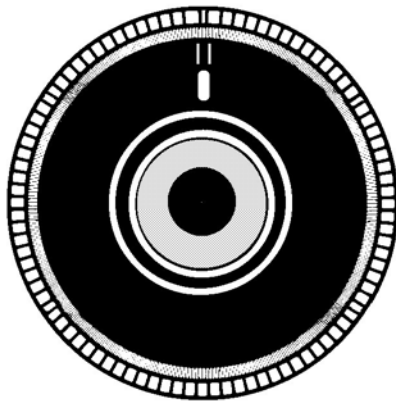

Figure 6-2: SCORA-ER 14Pro Encoder Disk

The photodetectors are arranged so that, alternately, some detect light while others do not. The photodiode outputs are then fed through the signal processing circuitry, resulting in the signals A, A, B, B, I and I, as shown in Figure 6-3.

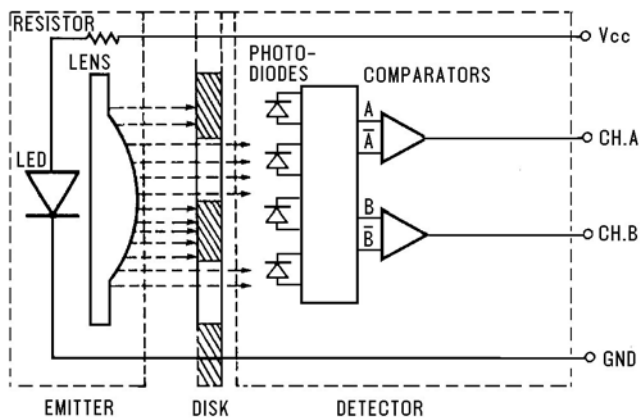

Figure 6-3: Encoder Circuitry

Comparators receive these signals and produce the final digital outputs for channels A, B and I. The output of channel A is in quadrature with that of channel B (90 out of phase), as shown in Figure 6-4. The final output of channel I is an index pulse.

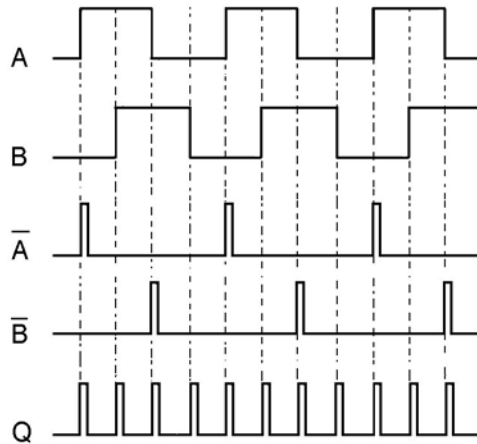

Figure 6-4: Encoder Output Signals

When the disk rotation is counterclockwise (as viewed from the encoder end of the motor), channel A will lead channel B. When the disk rotation is clockwise, channel B will lead channel A.

Encoder Resolution

From the quadrature signal the SCORA-ER 14Pro controller measures four counts for each encoder slot, thus quadrupling the effective resolution of the encoder.

The resolution of the encoder is expressed as:

$$S_E = \frac{360^\circ}{n}$$

Where:

S_E is the resolution of the encoder.

n is the number of counts per encoder revolution.

The encoders used in the SCORA-ER 14Pro have 512 slots, generating 2048 counts per motor revolution. The encoder resolution is therefore:

$$S_E = \frac{360^\circ}{2048} = .176^\circ$$

When the encoder resolution is divided by the overall gear ratio of the axis, the resolution of the joint is obtained.

Since the encoder is mounted on the motor shaft, and turns along with it, the resolution of the joint is expressed as:

$$S_{JOINT} = \frac{S_E}{N_{AXIS}}$$

Thus, for example, the resolution of joint 2 of the SCORA-ER 14Pro is therefore as follows:

$$S_{J_2} = \frac{0.176^\circ}{160} = .0011$$

The resolution is the smallest possible increment which the control system can identify and theoretically control. The accuracy of the axis - that is, the precision with which it is positioned - is affected by such factors as backlash, mechanical flexibility, and control variations.

End of Travel (Limit) Switches

The SCORA-ER 14Pro uses limit switches to prevent the joints from moving beyond their functional limits. When a control error fails to stop the axis at the end of its working range, the limit switch serves to halt its movement. The switch is part of an electric circuit within the robot arm, independent of the robot controller.

The limit switches used in the SCORA-ER 14Pro are shown in Figure 6-5.

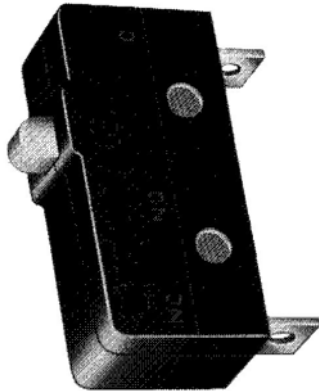

Figure 6-5: SCORA-ER 14Pro Limit Switch

Axes 1 and 2 each has two limit switches, one at each end of the axis' working range.

The limit switches are mounted on a disk which is attached to the robot's frame, as shown in Figure 6-6.

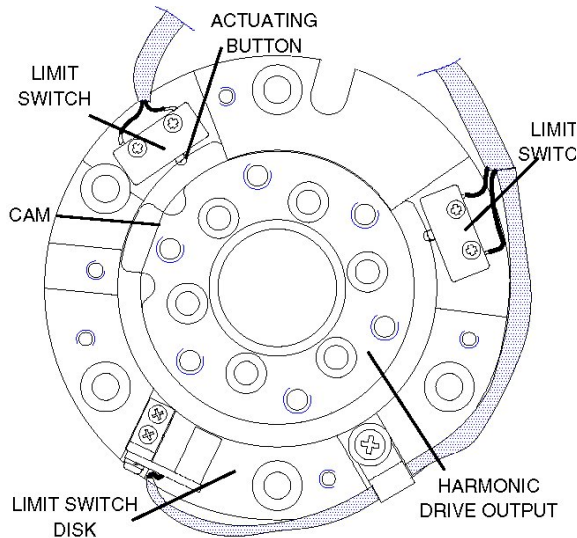

Figure 6-6: Limit Switch Activation

The output shaft of the Harmonic Drive moves relative to the microswitch disk. As the joint moves, a cam on the Harmonic Drive output shaft reaches a point at which it forces the actuating button of the limit switch into a position which activates the switch.

Axis 3 has two limit switches - one at the upper limit and one at the lower limit of the axis' range. The switches are mounted on the bracket alongside the spline (slider).

Axis 4 (roll) has no travel limit switches; it can rotate endlessly. When a gripper is attached to axis 4, its movements are controlled and limited by means of software only (encoder).

As shown in Figure 6-7, when limit switch 1 is activated (that is, when the button is depressed), the relay contact opens and the relay is deenergized. The motor cannot move the joint beyond this point. The diode allows the motor to reverse direction, thus permitting the joint to move away from the limit switch.

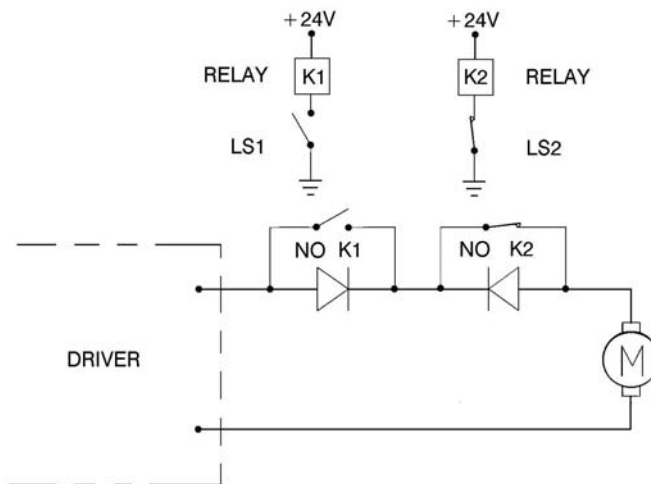

Figure 6-7: Axis Limit Circuit

When the limit switch is activated, it causes a control error, resulting in the activation of COFF, and an impact protection message.

CON must be activated and the robot arm must be manually moved (using keyboard or teach pendant) away from the impact condition.

As long as the axis has not reached one of its limits, the relay contact remains closed, and the diode has no effect on the circuit, as shown in Figure 6-8. Current can flow in either direction; the motor is thus able to rotate in either direction.

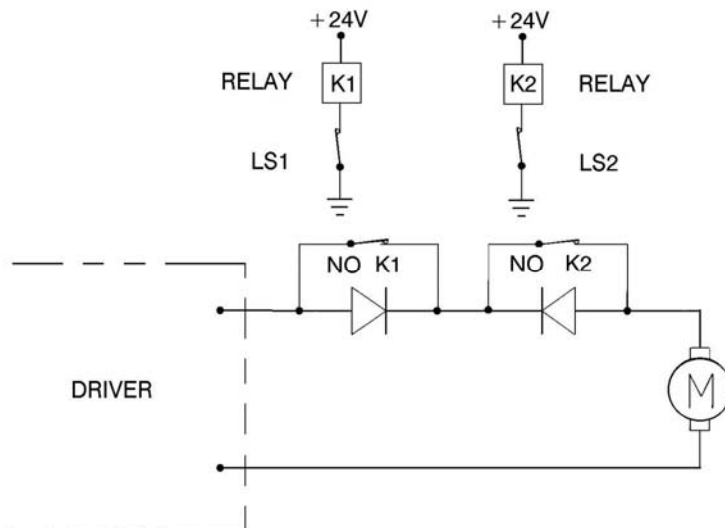

Figure 6-8: Axis Limit Circuit

Hard Stops

When the software limits and/or the end of travel switches fail to halt the movement of the robot arm, it is possible that the momentum of the robot arm will drive it until it reaches its mechanical limit.

When the joint reaches this hard stop, the impact protection and thermic protection processes detect an error, thus activating COFF.

CON must be activated and the robot arm must be manually moved away from the impact condition.

Home Switches

The SCORA-ER 14Pro uses an optical home switch on each axis to identify the fixed reference, or home, position.

For axes 1 and 2 the home switch is mounted on the same disk as the end of travel switches, and a flag is attached to the Harmonic Drive output shaft, as shown in Figure 6-9.

The home switch for axis 3 is located near the top of the bracket alongside the spline (slider), just below the axis' upper limit switch.

The home switch for axis 4 is located within the worm gear housing.

During the homing procedure, the robot joints are moved, one at a time. Each axis is moved until the flag cuts the beam of light. When that occurs, the optical detector on each joint sends a specific signal to the controller.

Once the home switch location has been detected, the axis motor continues to rotate until its encoder produces an index pulse. The point at which that occurs is the axis home position.

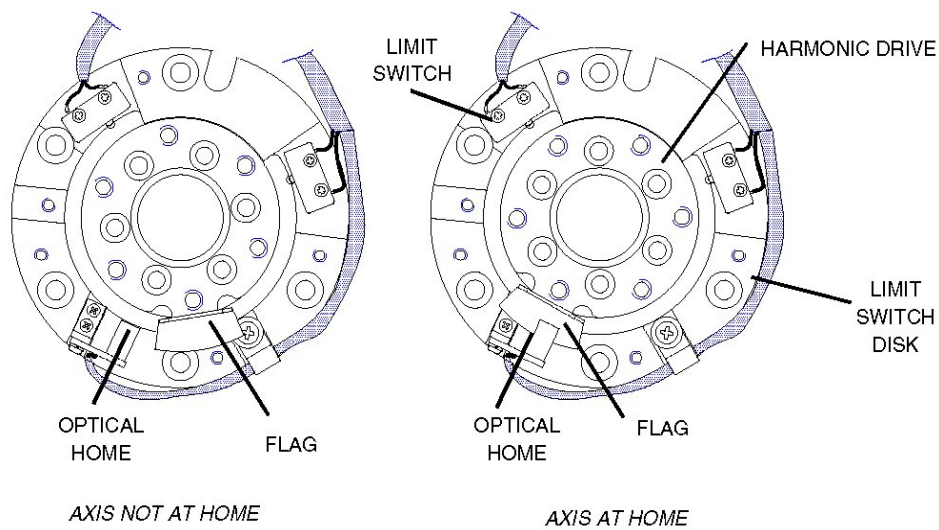

Figure 6-9: Home Switch Activation

7

Wiring

Figure 7-1 is a schematic diagram of the SCORA-ER 14Pro cable connections.

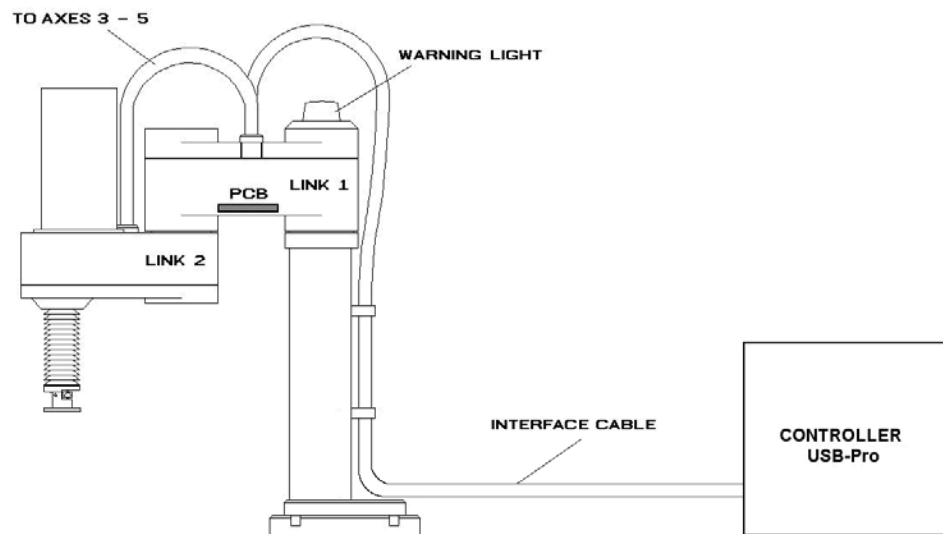

Figure 7-1: SCORA-ER 14Pro Cabling

The robot motors cable, encoder cable and warning light cable connect the Controller USB-Pro to the connector panel of the SCORA-ER 14Pro robot. Safety ground wires from the robot and the encoder cables are connected to safety ground studs on the connector panel and on the controller back panel.

The robot motors cable supplies power to the motors and +24VDC to the printed circuit board (PCB) located in link 1. The encoders cable supplies power to encoders, and carries information from the encoders and the home switches to the controller,. The warning light cable controls the warning light.

A wire braid links the connectors on the panel to the PCB, located in Link 1. A second braid connects the elements axes 3 – 5 (motors, encoders, limit and home switches, brake) to the PCB.

Robot Interface Cable

Interface cable includes: power lines to all motors, feedback encoder signals from all motors to the controller, feedback signals from optical home switches. It also contains air tubes and warning light wires.

Power Cable and Connector

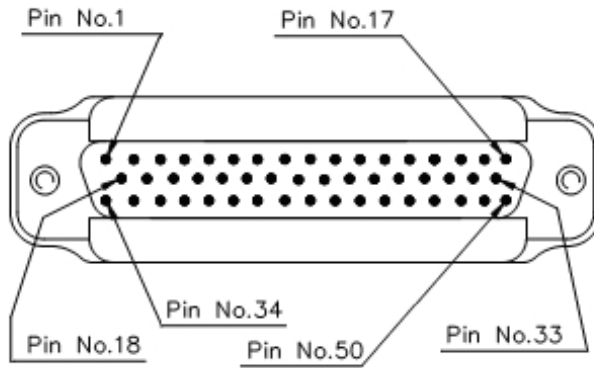

Figure 2: D50 Connector

Table 5: Robot (Motors Power Lines) Wiring and Pinout

Pin No.	Signal Name Robot Side (J22)	Wire Type and Color	Signal Name Controller Side
1, 2	Motor 1 -	Twisted Pair	Black
19, 20	Motor 1 +		Red
36, 37	Motor 2 -	Twisted Pair	Brown
5, 6	Motor 2 +		Orange
23, 24	Motor 3 -	Twisted Pair	Yellow
40, 41	Motor 3 +		Red
9, 10	Motor 4 -	Twisted Pair	Light Blue
27, 28	Motor 4 +		Blue
44, 45	Motor 5 -	Twisted Pair	Brown
13, 14	Motor 5 +		Grey
50	+24V to PCB	Twisted Pair	Red
17	24VRET to PCB		Black

Encoder Cables and Connectors

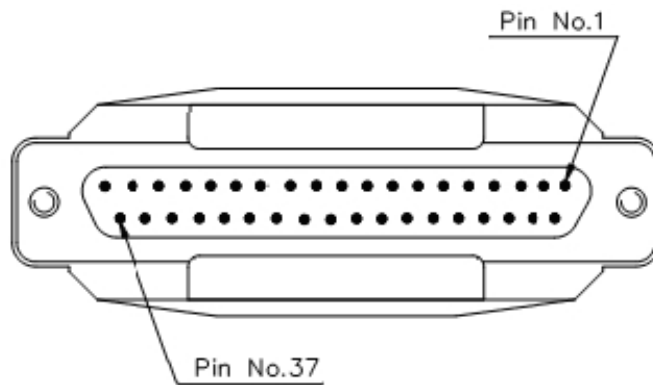

Figure 3: D37 Connector

Table 6: Robot (Motors Encoders Lines) Wiring and Pinout

Pin ID	Signal Name Robot Side	Axis	Wire Color	Signal Name Controller Side	Pin ID (D37)
J20-1	+5V	-	Pink	+5V	1
J20-2	+5V		Blue	+5V	2
J21-2	A1 (Encoder Pulse A)	1	White	CHA 0	5
J21-3	B1 (Encoder Pulse B)		Brown	CHB 0	6
J21-4	C1 (Encoder Index Pulse)		Green	CHC 0	7
J21-5	COMMON 1		Yellow	COMMON 0	8
J21-1	H1 (Home)		Grey	MSWITCH 0	31
J21-2	A2 (Encoder Pulse A)	2	White	CHA 1	9
J21-3	B2 (Encoder Pulse B)		Brown	CHB 1	10
J21-4	C2 (Encoder Index Pulse)		Green	CHC 1	11
J21-5	COMMON 2		Yellow	COMMON 1	12
J21-1	H2 (Home)		Grey	MSWITCH 1	32
J21-2	A3 (Encoder Pulse A)	3	White	CHA 2	13
J21-3	B3 (Encoder Pulse B)		Brown	CHB 2	14
J21-4	C3 (Encoder Index Pulse)		Green	CHC 2	15
J21-5	COMMON 3		Yellow	COMMON 2	16
J21-1	H3 (Home)		Grey	MSWITCH 2	33
J21-2	A4 (Encoder Pulse A)	4	White	CHA 3	17
J21-3	B4 (Encoder Pulse B)		Brown	CHB 3	18
J21-4	C4 (Encoder Index Pulse)		Green	CHC 3	19
J21-5	COMMON 4		Yellow	COMMON 3	20
J21-1	H4 (Home)		Grey	MSWITCH 3	34
J21-2	A5 (Encoder Pulse A)	5	White	CHA 4	21

Pin ID	Signal Name Robot Side	Axis	Wire Color	Signal Name Controller Side	Pin ID (D37)
J21-3	B5 (Encoder Pulse B)		Brown	CHB 4	22
J21-4	C5 (Encoder Index Pulse)		Green	CHC 4	23
J21-5	COMMON 5		Yellow	COMMON 4	24
J21-1	H5 (Home)		Grey	MSWITCH 4	35
-	Enable Signal	JUMPER	Black	COMMON2	16
-				ENABLE	37

Warning Light Cable

Table 7: Warning Light Cable

Pin ID	Signal Name Robot Side (J22)	Wire Color	Signal Name Controller Side
6	24V RET	Red	Relay NO/COM
8	Warning Light	Black	

8

Maintenance

The maintenance and inspection procedures recommended below will ensure the best possible performance of the robot over an extended period.

Daily Operation

At the start of each working session, check the robot and controller, in the following order:

1. Before you power on the system, check the following items:
 - The installation meets all safety standards.
 - All cables are properly and securely connected.
 - Cable connector screws are fastened.
 - The gripper is properly connected.
 - The air supply (for a pneumatic gripper) is functioning properly.
 - Any peripheral devices or accessories which will be used, such as the teach pendant or a remote **EMERGENCY** button, are properly connected to the controller.
2. After you have powered on the system, check the following items:
 - No unusual noises are heard.
 - No unusual vibrations are observed in any of the robot axes.
 - There are no obstacles in the robot's working range.
3. Bring the robot to a position near home, and activate the Home procedure. Check the following items:
 - Robot movement is normal.
 - No unusual noise is heard when robot arm moves.
 - Robot reaches home position in every axis.

Periodic Inspection

The following inspections should be performed regularly:

- Check robot mounting bolts for looseness using a wrench. Retighten as needed.
- Check all visible bolts and screws for looseness using a wrench and screwdriver. Retighten as needed.

- Check cables. Replace if any damage is evident.

The following robot components may require replacing after prolonged use of the robotic arm causes them to wear or fail:

- DC Servo Motors
- Motor Brushes
- Timing Belts
- V-Rings
- Harmonic Drives
- Cross-Roller Bearings

Troubleshooting

Whenever you encounter a problem with your system, try to pinpoint its source by exchanging the suspected faulty component for example, robot, controller, teach pendant, cable with one from a functioning system.

In general, when trying to determine the source of a malfunction, first check the power source and external hardware, such as controller switches, LEDs and cable connections. Then check fuses; you may also open the controller to check components, according to the procedures and instructions detailed in the Controller USB-Pro User Manual.

In addition, make sure the controller is properly configured for the robot and gripper, the software commands have been correctly issued, and system parameters are properly set.

All troubleshooting procedures described in the section can be performed by the user.

- ☞ *Do not attempt to open the robot arm. There are no user-serviceable parts inside.*
- ☞ *Do not alter Scorbase system parameters*

If you are unable to determine and/or correct the problem, contact your service representative. Only qualified technicians may remove and/or replace robot components.

1. Controller functioning, but the robot cannot be activated.

- Make sure Scorbase is in Online Mode. Select **Options | On-line** from the Menu bar.
- Make sure an obstacle is not blocking the robot.
- Make sure the green Motors LED is lit.
- Make sure the controller is in the control off (COFF) state. Then activate the control on (CON) state from the PC or TP.
- Make sure all robot and encoder cables are properly connected.

2. *Robot does not find Home position in one or all of the axes.*

- Make sure the homing command was properly issued.
- Make sure all robot and encoder cables are properly connected.
- Make sure Scorbase is correctly configured. Refer to the Scorbase for ER 9Pro/ER 14Pro User Manual.
- Make sure system homing parameters are properly set. Refer to the Scorbase for ER 9Pro/ER 14Pro User Manual.
- Check whether the optical home switch for this axis is functioning.

To do this:

1. Select **View | Movement Information**.
2. Physically move each axis in the two directions in which it moves while watching the Movement Information window. The area in which the axis value in Home Switch reads “0” is the axis’ Home area. Where the value is “1” is outside it’s Home area.

If the axis’ value in the **Movement Information** window does not change, possible causes are:

- Faulty arm circuitry.
- Faulty optical switch; optical switch not properly mounted.
- Faulty driver circuitry

3. *One of the axes does not function.*

- Check the axis' fuse on the rear panel of the Controller.
- Check the encoder:

Select **View | Dialog Bars | Encoder Counts** to display the encoder readings.

Click the **Control Off**  icon (to disable servo control) and then physically move the axis in question in both directions.

The encoder reading should rise for rotation in one direction and fall for rotation in the opposite direction. If this does not occur, there is a problem in the encoder or its circuitry.

If the encoder readings do not change, check whether the encoder connector is properly connected to the rear controller panel.

The problem may be caused by faulty encoder connectors on the robot's internal PCB's.

4. *Errors in the repeatability of the robot.*

- Try to identify the faulty axis. If many or all axes are faulty, look for an electrical noise source in your environment.
- Check the controller's ground and the robot's ground connection to the safety ground terminal at the back of the controller.
- Check the encoder.

Bring the robot to a starting position. Using a pencil, draw a fine, continuous line on the robot which crosses from the cover of one link to the cover of the adjacent link at the joint in question.

Select **View | Dialog Bars | Encoder Counts** to display the encoder readings.

Click the **Control Off**  icon (to disable servo control) and then physically move the axis in question to another position. Then return to the starting position marked by the line you drew. Check the encoder reading for the axis again. It should be within 5 counts of the previous reading; if not, the encoder needs to be replaced.

☞ Note for more precision in repeatability always start from the same position when moving to a specific location. Thus wherever the axis in question is located, always move to the end point via the same specific position.

5. *Unusual noise.*

- Loose screws.
- Poor lubrication.
- Ratcheting.
- Worn motor brushes.
- Worn timing belt.
- Damaged harmonic drive.

6. *Unusual smell.*

- A motor or an internal PCB has burnt out and needs to be replaced.

7. *Axis/axes vibrating, too weak to carry load, motion not smooth, or jerks during or at end of motion.*

- System parameters are not properly adjusted.

Refer to the Scorbase for ER 9Pro/ER 14Pro User Manual.

- Problem in axis driver card(s) in the controller.

Refer to the Controller USB-Pro User Manual.

8. *Pneumatic gripper does not respond.*

- Check that all air hoses are connected properly.
- Make sure the gripper is connected to the proper controller output.
- Check the relay output to which the gripper is connected.
- Check whether the relays have been switched (LED is lit):
- When an output is in OFF state, NC contact is shorted to COM, and NO contact is disconnected from COM.
- When an output is in ON state, NO contact is shorted to COM, and NC contact is disconnected from COM.
- Check gripper configuration hardware setup. select **Options | Hardware Setup**.

9. *Error Messages*

- For details on error messages refer to the System Messages chapter in the Scorbase for ER 9Pro/ER 14Pro User Manual.