

**PCI Express
Gigabit Ethernet Adapter**

ENW-9700

User's Manual

Version 1.0

Copyright

Copyright © 2005 by PLANET Technology Corp. All rights reserved. No part of this publication may be reproduced, transmitted, transcribed, stored in a retrieval system, or translated into any language or computer language, in any form or by any means, electronic, mechanical, magnetic, optical, chemical, manual or otherwise, without the prior written permission of PLANET.

PLANET makes no representations or warranties, either expressed or implied, with respect to the contents hereof and specifically disclaims any warranties, merchantability or fitness for any particular purpose. Any software described in this manual is sold or licensed "as is". Should the programs prove defective following their purchase, the buyer (and not PLANET, its distributor, or its dealer) assumes the entire cost of all necessary servicing, repair, and any incidental or consequential damages resulting from any defect in the software. Further, PLANET reserves the right to revise this publication and to make changes from time to time in the contents hereof without obligation to notify any person of such revision or changes.

All brand and product names mentioned in this manual are trademarks and/or registered trademarks of their respective holders.

FCC Caution

To assure continued compliance. (example-use only shielded interface cables when connecting to computer or peripheral devices). Any changes or modifications not expressly approved by the party responsible for compliance could void the user's authority to operate the equipment.

This device complies with Part 15 of the FCC Rules. Operation is subject to the Following two conditions: (1) This device may not cause harmful interference, and (2) this Device must accept any interference received, including interference that may cause undesired operation.

CE Mark Warning

This is a Class B product. In a domestic environment, this product may cause radio interference in which case the user may be required to take adequate measures.

Revision

User's Manual for PLANET PCI Express Gigabit Ethernet Adapter

Model: ENW-9700

Rev: 1.0 (April, 2005)

Part No. 2080-A14080-000

Table of Contents

CHAPTER 1	INTRODUCTION.....	1
1.1	PACKAGE CONTENT.....	1
1.2	FEATURES.....	1
1.3	VERIFYING YOUR SYSTEM REQUIREMENTS.....	1
1.4	GATHERING TOOLS AND DOCUMENTATIONS.....	2
CHAPTER 2	HARDWARE INSTALLATION.....	3
2.1	LED DEFINITIONS.....	3
2.2	HARDWARE INSTALLATION.....	4
CHAPTER 3	DRIVER INSTALLATION.....	5
3.1	INSTALLING DRIVER TO WINDOWS 2000.....	5
3.2	INSTALLING DRIVER TO WINDOWS XP / SERVER 2003.....	7
CHAPTER 4	UTILITY.....	9
4.1	INSTALLATION INSTRUCTIONS.....	9
4.2	UTILITY OPERATING.....	11
CHAPTER 5	SPECIFICATIONS.....	12
APPENDIX A	ADVANCED PROPERTIES.....	13

Chapter 1 Introduction

Meet the next generation interface - PCI Express. Gigabit Ethernet can perfectly provide the best solution for one of the major issues of Local Area Networks - communication speed. Ten times as fast as the existing 100Base-TX solutions, using the PLANET ENW-9700 to connect your servers and workstations guarantees extremely high throughput and excellent signal quality.

The ENW-9700 is a PCI Express Gigabit Ethernet adapter designed to address high-performance system application requirements. With the higher bandwidth of x1 PCI Express Bus Architecture, ENW-9700 can provide better performance than the network cards which base on 32/64bit PCI architecture. It is specifically designed to allow throughput at rates up to 2Gbps, thus eliminating the existing 32/64bit PCI network card.

1.1 Package Content

Check that your package contains the following items:

- ✓ 1 x ENW-9700
- ✓ 1 x Quick Installation Guide
- ✓ 1 x CD-ROM

Please contact the seller if any of the items is missing or damaged.

Note: Be sure to retain your proof of purchase, as it is required to receive warranty service.

1.2 Features

- Compliant with PCI Express 1.0a - x1 PCI Express standard
- Auto-Negotiation determines the transmission speed at 10/100/1000 Mbps and Full/Half duplex mode
- Supports CSMA/CD protocol
- Supports Auto-MDI/MDI-X to swap the transmission and reception
- Integrated 128KB Frame Buffer Memory
- Supports WOL (Wake on LAN) function to power management support (through PCI Express interface)
- Supports Preboot Execute Environment (PXE) 2.1
- ACPI Power Management, compliant to ACPI 2.0

1.3 Verifying Your System Requirements

Before installing the ENW-9700, be sure your computer meets the following requirements:

Hardware

- ✓ CPU: 300MHz or Faster

- ✓ RAM: 64MB (Minimum)
- ✓ x1 PCI Express compliant

Software

- ✓ Microsoft Windows 2000 / XP / Server 2003

1.4 Gathering Tools And Documentations

To install the adapter, you need the following items:

- ✓ A suitable screw driver
- ✓ Your operating system documentation
- ✓ Your system unit documentation, including any service documentation

Chapter 2 Hardware Installation

2.1 LED definitions

The faceplate of ENW-9700 has three LEDs: 100, 1000 and ACT. The pictures below have showed the faceplate of ENW-9700. Table 2-1 explains the function and state of the LEDs.

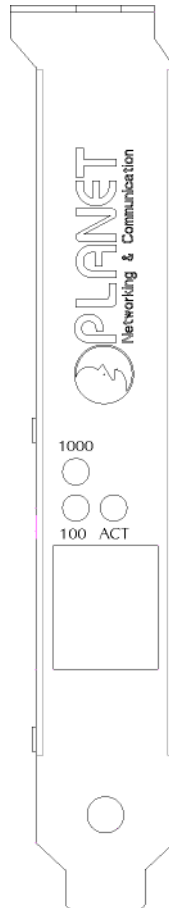

Faceplate of ENW-9700

LED	Description
1000	1000 LED On: Indicates ENW-9700 is work with 1000Mbps.
100	100 LED On: Indicates ENW-9700 is work with 100Mbps Both Off: Indicates ENW-9700 is work with 10Mbps.
ACT	Blink: Indicates ENW-9700 is transferring and receiving data.

Table 2-1 Descriptions of ENW-9700 LEDs

2.2 Hardware Installation

Step 1: Please turn off your PC.

Step 2: Remove any metal decorations from your hands and wrists.

Step 3: Remove the cover from your PC.

Step 4: Locate an empty PCI Express slot and remove the corresponding back plate. Save the screw for use in Step 6.

Step 5: Carefully insert the adapter into the chosen slot and press firmly with proper push to ensure it is fully seated in the slot.

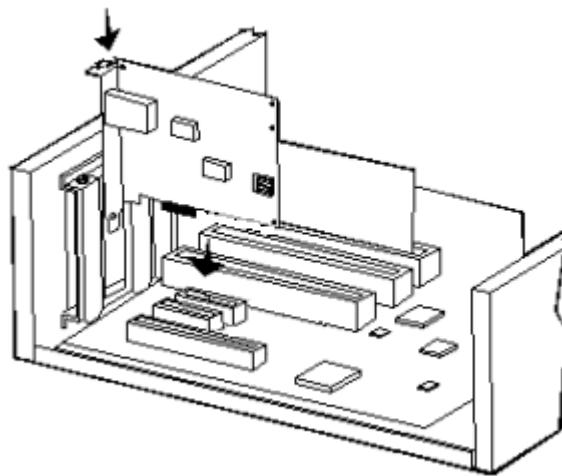

Step 6: Secure the adapter with the screw you saved in step 4.

Step 7: Replace the PC cover.

Step 8: Power on the PC and refer to next chapter to install the driver of this adapter.

Chapter 3 Driver Installation

A device driver must be installed before your ENW-9700 can be used with your computer. This chapter describes how to install the driver for various operating systems. Before you begin the driver installation process, make sure you have the installation disks for your computer's operation system nearby.

3.1 Installing Driver To Windows 2000

Make sure the ENW-9700 has been successfully inserted in your computer before you start to install the driver. If this is the first time you install the ENW-9700 into your computer, Windows will automatically detect it and updates the hardware information database. To install the driver provided, please follow the steps below:

1. Install ENW-9700 into your PC's PCI Express slot.
2. Power on the PC and insert Driver Disk into CD-ROM drive.
3. Windows will automatically detect ENW-9700 and ask the user to install driver. Please click "Next".



4. Please select the first option and click "Next" to continue.

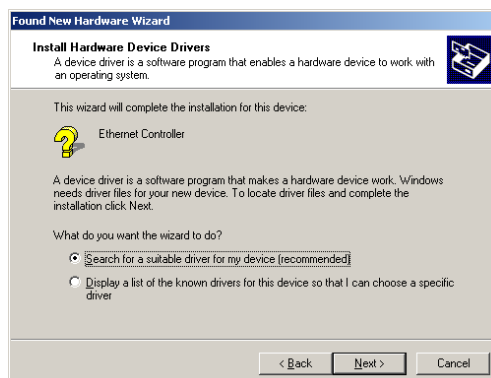

5. Select "Specify a location" and click "Next".

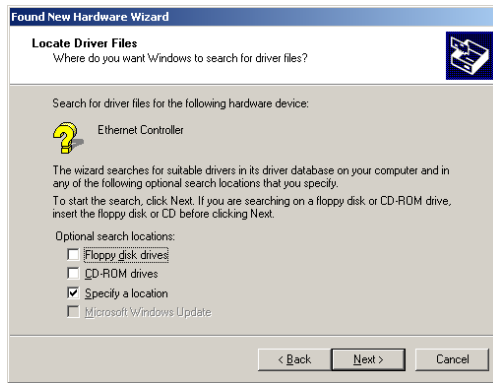

- You can click "Browse" to specify the driver location. (Assume "E" is your CD-ROM drive, the driver can be found in E:\Drivers\Win2K). Please click "OK" to continue.



- Windows will show this screen to prompt you that it finds a driver for the device you are installing, please click "Next" to continue.

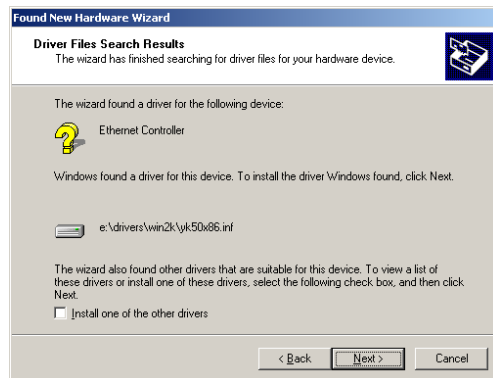

- Windows may prompt you this driver is not digitally signed by Microsoft. If the device name is correct, please press "Yes" to continue.

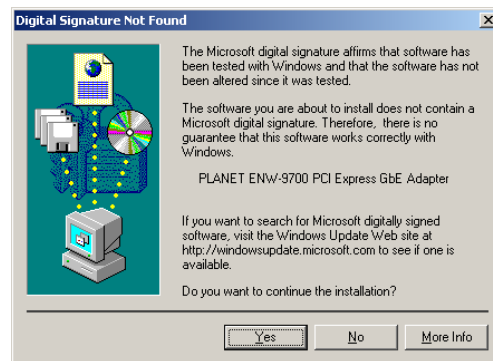

- Please click "Finish" to complete the driver installation.

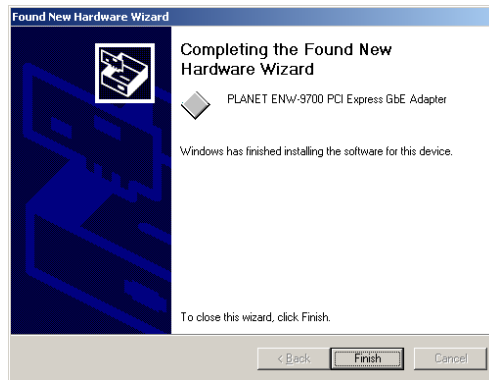

(In Win98/Me, Windows will ask you restart your PC when driver installation finished.)

3.2 Installing Driver To Windows XP / Server 2003

Note: *The following installation operates under Window XP. Procedures will be similar to Window Server 2003.*

1. Install ENW-9700 into your PC's PCI Express slot.
2. Power on the PC and insert Driver Disk into CD-ROM drive.
3. Windows XP will detect ENW-9700 and ask you to install driver. Please select the second option and click "Next".

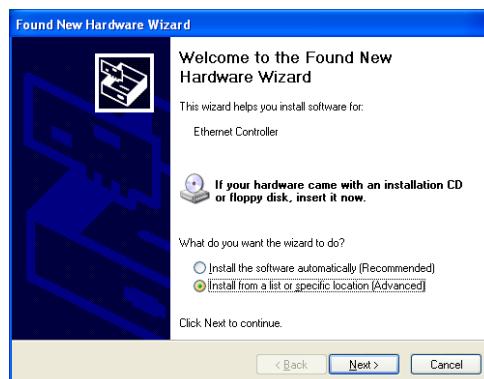

4. Please select "Include this location in the search" and then click "Browse" to specify ENW-9700 driver location to install. (Assume "E" is your CD-ROM drive, you can find ENW-9700 driver in E:\Drivers\WinXP). Please click "Next" to continue.



5. WinXP will show you this dialog box to prompt you the driver is not digitally signed by Microsoft, please press “Continue Anyway” to continue.



6. Please click “Finish” to complete the driver installation.

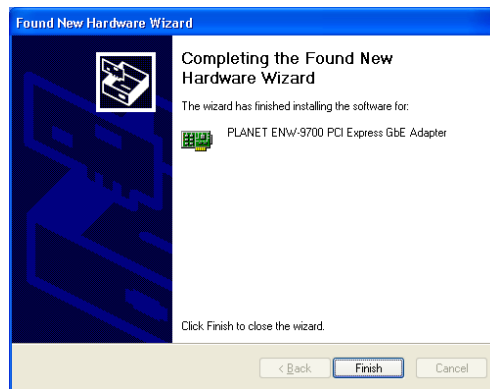

Chapter 4 Utility

ENW-9700 is VCT Technology supported. The Virtual Cable Tester(TM) installation package contains the Marvell Virtual Cable Tester(TM) application. This utility can help user to diagnostic the cable status and verify the cable distance.

Note: The Marvell Virtual Cable Tester(TM) can only be used with Windows 2000 / XP and Server 2003.

4.1 Installation Instructions

1. Run "setup.exe" under "E:\Utility\VCT" directory. Or click the "Start" button and choose "Run", please enter "E:\Utility\VCT\setup.exe" to the dialog box (Assume "E" is your CD-ROM drive). You will see the dialog box as below. Please click "Next" to continue.

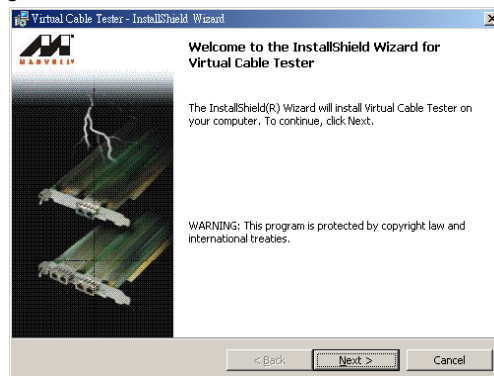

2. Please select the first option "I accept the terms in the licensee agreement" and click "Next" to continue.

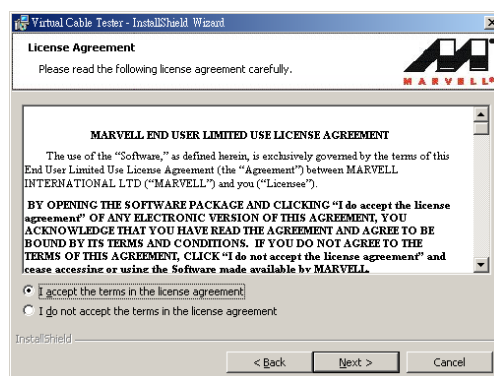

3. Please check the installation note and click "Next" to continue.

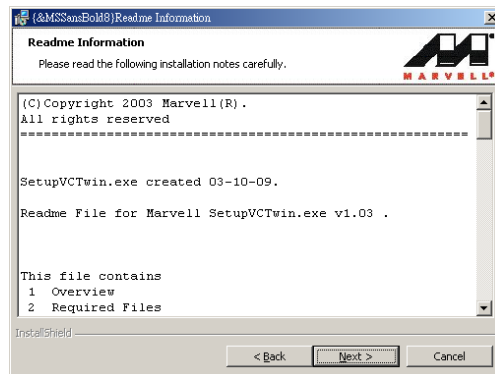

4. Please click "Install" to begin the installation.

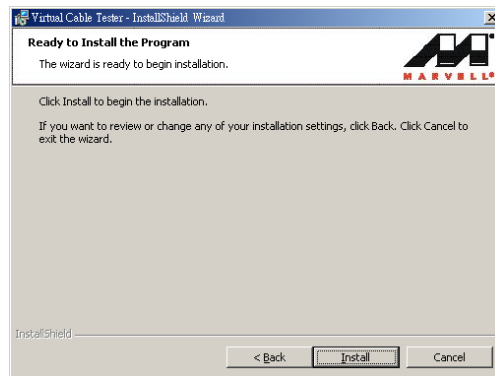

5. Please click "Finish" to complete the utility installation.

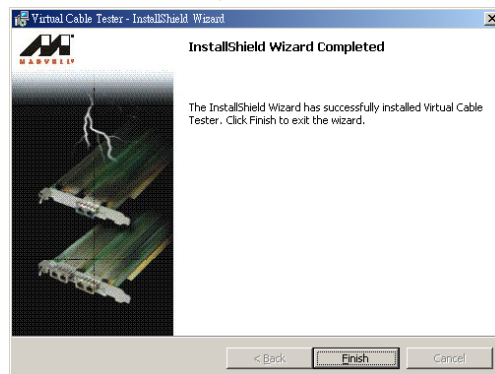

4.2 Utility Operating

After installation, you can find the utility in "Start" => "Programs" => "Marvell" => "Virtual Cable Tester". Please click "Virtual Cable Tester" option to start. If you have see the dialog box as below, please make sure you are using ENW-9700 and the card had been install to your PC properly.



When the utility starts, you will see the screen as below. If you have install two or more ENW-9700 to your PC, please select the card you want to test in the first field, then click "Run" button the diagnostic the cable status of selected ENW-9700 connected.

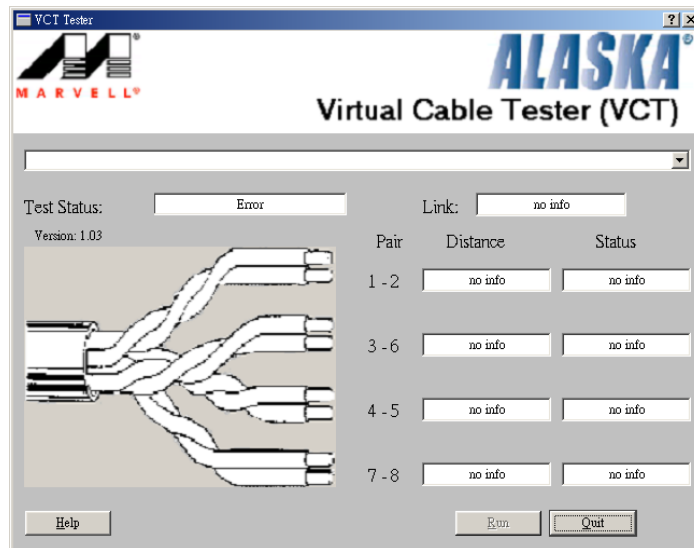

Chapter 5 Specifications

Model	ENW-9700
Standards	IEEE 802.3 IEEE 802.3u IEEE802.3ab
Connectors	RJ-45
LEDs	100 / 1000 / ACT
Cabling Requirements	4-pair, Category 5 Category 5 enhanced
Speed	Full duplex mode: 20/200/2000 Mbps
Bus Type	PCI Express 1.0a - x1 PCI Express
Protocol	CSMA/CD
OS Supported	Windows 2000/XP/Server 2003
Dimensions	89*121*21 mm (L x H x W)
Weight	42 g
Operating Temperature	0° to 40°C (32° to 107°F)
Storage Temperature	-40° to 70°C (-40° to 158°F)
Operating Humidity	10% to 95% relative humidity, non-condensing
Storage Humidity	0% to 95% relative humidity, non-condensing
EMC Certification	FCC Class A, CE

Appendix A Advanced Properties

The default settings of the adapter should work in most cases. However, if you experience any unusual circumstances during your installation, these settings may help you to trouble shoot the adapter. Do not change any of these settings without a thorough understanding on your network. The following table briefly explains the function of each property.

Parameter	Description	Value
802.1p Support Port A	The IEEE 802.1P signaling method is used for traffic prioritization at OSI Reference Model Layer 2. It is implemented in network adapters and switches for best-effort Quality of Service (QoS).	Off (default) On
Log Status Messages	This parameter specifies the messages, which are to be logged in the Event Log.	All Messages Errors None Status Messages (default) Warnings
Maximum Frame Size	Specifies the maximum frame size in bytes that the driver will support. The performance of your network usually increases when a large packet size is used. Do not use values larger than 1514 if you are not sure the network structure supports jumbo frames.	12-9014 (default: 1514)
Media Type	Specify the link speed of the adapter. For ENW-9700, this option is fixed to Autosense.	100Mbps Full Duplex 100Mbps Half Duplex 10Mbps Full Duplex 10Mbps Half Duplex Autosense (default)
Network Address	Allow the user to configure the network address of the adapter.	Not Present
Number Of Receive Buffers	Defines the number of receive buffers allocated by the driver. If the system does not have enough resources, the driver will fail to load. Increasing this value may improve performance.	3-500 (default: 50)
Number Of Transmission Buffers	Defines the number of transmit buffers allocated by the driver. If the system does not have enough resources, the driver will fail to load. Increasing this value may improve performance.	4-500 (default: 50)
Wake Up Capabilities	Specify which method is using to activate the Wake-On-LAN capability. It is only available on ENW-9700.	Link Change Magic Packet Magic Packet and Pattern Match (default) None OS Controlled Pattern Match

Distributed by:

