

Kramer Electronics, Ltd.



USER MANUAL

Model:

FC-321

SD/HD-SDI to HDMI Converter/Switcher

Contents

| | | |
|----------|---|----------|
| 1 | Introduction | 1 |
| 2 | Getting Started | 1 |
| 2.1 | Quick Start | 2 |
| 3 | Overview | 2 |
| 3.1 | About HDMI | 3 |
| 3.2 | Recommendations for Best Performance | 4 |
| 4 | Your FC-321 SD/HD-SDI to HDMI Converter/Switcher | 4 |
| 5 | Connecting the FC-321 | 6 |
| 6 | Technical Specifications | 8 |

Figures

| | | |
|-----------|--|---|
| Figure 1: | FC-321 SD/HD-SDI to HDMI Converter/Switcher | 5 |
| Figure 2: | Connecting the FC-321 SD/HD-SDI to HDMI Converter/Switcher | 7 |

Tables

| | | |
|----------|--|---|
| Table 1: | FC-321 SD/HD-SDI to HDMI Converter/Switcher Features | 6 |
| Table 2: | Technical Specifications of the FC-321 | 8 |

1 Introduction

Welcome to Kramer Electronics! Since 1981, Kramer Electronics has been providing a world of unique, creative, and affordable solutions to the vast range of problems that confront the video, audio, presentation, and broadcasting professional on a daily basis. In recent years, we have redesigned and upgraded most of our line, making the best even better! Our 1,000-plus different models now appear in 11 groups¹ that are clearly defined by function.

Thank you for purchasing the Kramer DigiTOOLS® **FC-321 SD/HD-SDI to HDMI Converter/Switcher**, which is ideal for:

- Home theater, presentation and multimedia applications
- Rental and staging

The package includes the following items:

- **FC-321**
- Power supply (5V DC input)
- This user manual²

2 Getting Started

We recommend that you:

- Unpack the equipment carefully and save the original box and packaging materials for possible future shipment
- Review the contents of this user manual
- Use Kramer high-performance high-resolution cables³

1 GROUP 1: Distribution Amplifiers; GROUP 2: Switchers and Matrix Switchers; GROUP 3: Control Systems; GROUP 4: Format/Standards Converters; GROUP 5: Range Extenders and Repeaters; GROUP 6: Specialty AV Products; GROUP 7: Scan Converters and Scalers; GROUP 8: Cables and Connectors; GROUP 9: Room Connectivity; GROUP 10: Accessories and Rack Adapters; GROUP 11: Sierra Products

2 Download up-to-date Kramer user manuals from our Web site at <http://www.kramerelectronics.com>

3 The complete list of Kramer cables is on our Web site at <http://www.kramerelectronics.com>

2.1 Quick Start

This quick start chart summarizes the basic setup and operation steps.

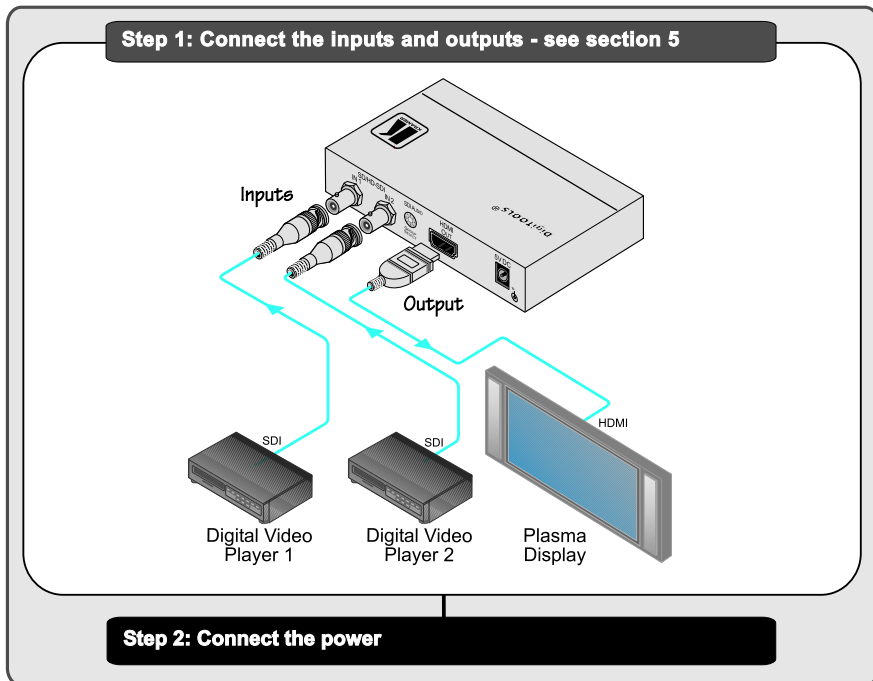

3 Overview

The **FC-321 SD/HD-SDI to HDMI Converter/Switcher** is a high-performance format converter for SDI (SMPTE 259M), HD-SDI (SMPTE 292M), and 3G HD-SDI (SMPTE 424M) signals. It converts one of two SDI video and audio signals to an HDMI output signal with the same resolution and frame rate¹.

The **FC-321** features:

- Two SD/HD-SDI/3G HD-SDI inputs on BNC connectors
- One HDMI output with HDTV compatibility
- An SDI audio group select rotary switch

¹ No scaling is performed

- Automatic active input LED indicators on the front panel. Green indicates a standard definition (SDI) input signal and blue indicates a high-definition (HD-SDI) input signal
- 5V DC power

3.1 About HDMI

High-Definition Multimedia Interface (HDMI) is an uncompressed all-digital¹ audio/video interface, widely supported in the entertainment and home cinema industry. It delivers the highest high-definition image and sound quality. Note that Kramer Electronics Limited is an HDMI Adopter² and an HDCP Licensee³. In particular, HDMI⁴:

- Provides a simple⁵ interface between any audio/video source, such as a set-top box, DVD player, or A/V receiver and video monitor, such as a digital flat LCD / plasma television (DTV), over a single⁶ cable
- Supports standard, enhanced, high-definition video, and multi-channel digital audio⁷ on a single cable
- Transmits all ATSC HDTV standards and supports 8-channel digital audio, with bandwidth to spare to accommodate future enhancements and requirements
- Benefits consumers by providing superior, uncompressed High Definition digital video via a single cable⁸, and user-friendly connector
- Is backward-compatible with DVI (Digital Visual Interface)

1 Ensuring an all-digital rendering of video without the losses associated with analog interfaces and their unnecessary digital-to-analog conversions

2 See http://www.hdmi.org/about/adopters_founders.asp

3 See <http://www.digital-cp.com/list/>

4 HDMI, the HDMI logo and High-Definition Multimedia Interface are trademarks or registered trademarks of HDMI licensing LLC

5 With video and multi-channel audio combined into a single cable, the cost, complexity, and confusion of multiple cables currently used in A/V systems is reduced

6 HDMI technology has been designed to use standard copper cable construction at up to 15m

7 HDMI supports multiple audio formats, from standard stereo to multi-channel surround-sound. HDMI has the capacity to support Dolby 5.1 audio and high-resolution audio formats

8 HDMI provides the quality and functionality of a digital interface while also supporting uncompressed video formats in a simple, cost-effective manner

- Supports two-way communication between the video source (such as a DVD player) and the digital television, enabling new functionality such as automatic configuration and one-button play

HDMI has the capacity to support existing high-definition video formats (720p, 1080i, and 1080p/60), as well as standard definition formats such as NTSC or PAL.

3.2 Recommendations for Best Performance

To achieve the best performance:

- Use only good quality connection cables¹ to avoid interference, deterioration in signal quality due to poor matching, and elevated noise levels (often associated with low quality cables).
- Avoid interference from neighboring electrical appliances that may adversely influence signal quality and position your Kramer **FC-321** away from moisture, excessive sunlight and dust



Caution – No operator-serviceable parts inside unit.

Warning – Use only the Kramer Electronics input power wall adapter that is provided with this unit².

Warning – Disconnect power and unplug unit from wall before installing or removing device or servicing unit.

4 Your FC-321 SD/HD-SDI to HDMI Converter/Switcher

*Figure 1 and Table 1 define the **FC-321 SD/HD-SDI to HDMI Converter/Switcher**.*

¹ Available from Kramer Electronics on our Web site at <http://www.kramerelectronics.com>

² For example, part number 2535-052002

Your FC-321 SD/HD-SDI to HDMI Converter/Switcher

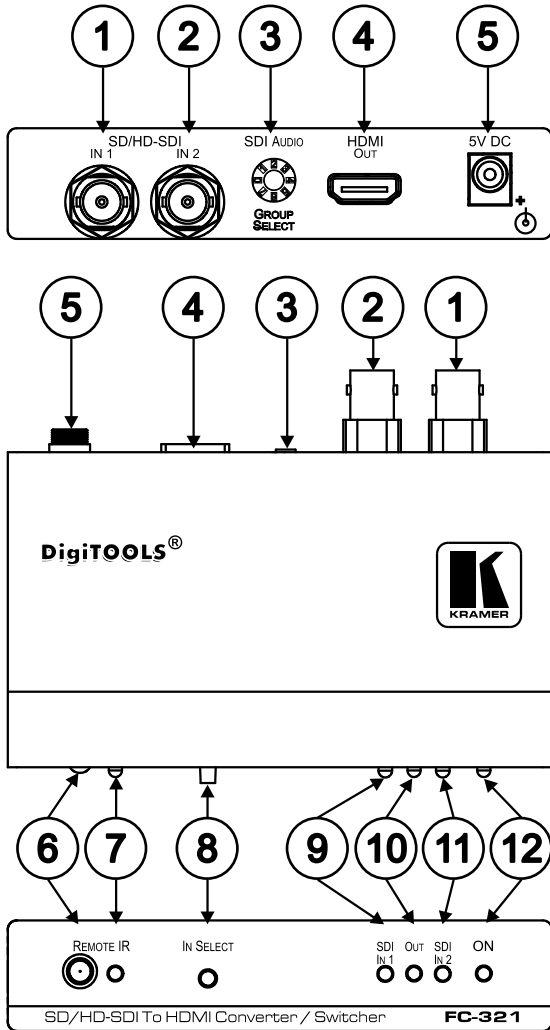

Figure 1: FC-321 SD/HD-SDI to HDMI Converter/Switcher

Table 1: FC-321 SD/HD-SDI to HDMI Converter/Switcher Features

| # | Feature | Function |
|----|------------------------------|--|
| 1 | SD/HD-SDI IN 1 BNC Connector | Connects to the SD or HD-SDI source 1 |
| 2 | SD/HD-SDI IN 2 BNC Connector | Connects to the SD or HD-SDI source 2 |
| 3 | SDI AUDIO GROUP SELECT | Turn to select the input stereo channel (0 to 7) |
| 4 | HDMI OUT Connector | Connects to an HDMI acceptor |
| 5 | 5V DC | +5V DC connector for powering the unit |
| 6 | REMOTE IR Sensor | Receives the input from an IR remote control |
| 7 | REMOTE IR LED | Flashes red when receiving an IR signal |
| 8 | IN SELECT Pushbutton | Press to toggle between SDI 1 IN and SDI 2 IN |
| 9 | SDI 1 IN LED | Illuminates green for an SD input signal and blue for an HD input signal on HD-SDI 1 |
| 10 | OUT LED | Illuminates green to indicate that the display is connected |
| 11 | SDI 2 IN LED | Illuminates green for an SD input signal and blue for an HD input signal on HD-SDI 2 |
| 12 | ON LED | Illuminates green when receiving power |

5 Connecting the FC-321

To connect the **FC-321**, as the example in *Figure 2* illustrates, do the following¹:

1. Connect a digital video source (for example, a digital video player 1) to the SD/HD-SDI IN 1 connector.
2. Connect a digital video source (for example, a digital video player 2) to the SD/HD-SDI IN 2 connector.
3. Connect the HDMI connector to an HDMI acceptor (for example, a plasma display).
4. Using a small screwdriver, turn the SDI AUDIO GROUP SELECT rotary switch to select an SDI stereo channel² from 0 to 7.
5. Connect the 5V DC power adapter to the power socket and connect the adapter to the mains electricity (not illustrated in *Figure 2*).

1 Switch OFF the power on each device before connecting it to your FC-321. After connecting your FC-321, switch on its power and then switch on the power on each device

2 SDI audio is made up of 16 channels of audio information or 8 stereo pairs. Whereas most other devices access a group of 2-pairs, the FC-321 accesses a single pair out of a group for higher discrimination

Connecting the FC-321

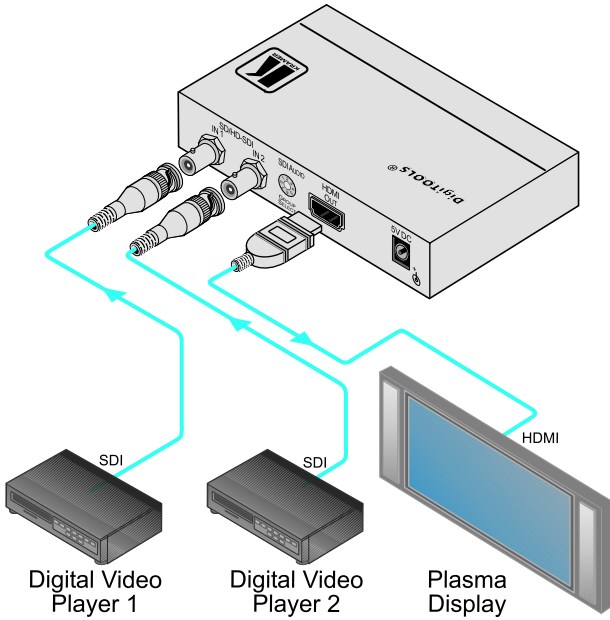

Figure 2: Connecting the FC-321 SD/HD-SDI to HDMI Converter/Switcher

6 Technical Specifications

The **FC-321** technical specifications are shown in *Table 2*:

Table 2: Technical Specifications¹ of the FC-321

| | |
|----------------------|---|
| INPUTS: | 2 SD/HD-SDI, 3G HD-SDI on a BNC connector |
| OUTPUT: | 1 HDMI connector |
| MAX DATA RATE: | Up to 3Gbps |
| STANDARD COMPLIANCE: | HDMI 1.3 |
| INDICATOR LEDS: | SD/HD, OUT, ON |
| POWER SOURCE: | 5V DC, 450mA |
| DIMENSIONS | 12cm x 7.2cm x 2.4cm (4.7" x 2.8" x 1.0") W, D, H |
| WEIGHT: | 0.3kg (0.7lbs) |
| ACCESSORIES: | Power supply |
| OPTIONS: | 19" rack mount adapter |

¹ Specifications are subject to change without notice

LIMITED WARRANTY

Kramer Electronics (hereafter *Kramer*) warrants this product free from defects in material and workmanship under the following terms.

HOW LONG IS THE WARRANTY

Labor and parts are warranted for seven years from the date of the first customer purchase.

WHO IS PROTECTED?

Only the first purchase customer may enforce this warranty.

WHAT IS COVERED AND WHAT IS NOT COVERED

Except as below, this warranty covers all defects in material or workmanship in this product. The following are not covered by the warranty:

1. Any product which is not distributed by Kramer, or which is not purchased from an authorized Kramer dealer. If you are uncertain as to whether a dealer is authorized, please contact Kramer at one of the agents listed in the Web site www.kramerelectronics.com.
2. Any product, on which the serial number has been defaced, modified or removed, or on which the WARRANTY VOID IF TAMPERED sticker has been torn, reattached, removed or otherwise interfered with.
3. Damage, deterioration or malfunction resulting from:
 - i) Accident, misuse, abuse, neglect, fire, water, lightning or other acts of nature
 - ii) Product modification, or failure to follow instructions supplied with the product
 - iii) Repair or attempted repair by anyone not authorized by Kramer
 - iv) Any shipment of the product (claims must be presented to the carrier)
 - v) Removal or installation of the product
 - vi) Any other cause, which does not relate to a product defect
 - vii) Cartons, equipment enclosures, cables or accessories used in conjunction with the product

WHAT WE WILL PAY FOR AND WHAT WE WILL NOT PAY FOR

We will pay labor and material expenses for covered items. We will not pay for the following:

1. Removal or installations charges.
2. Costs of initial technical adjustments (set-up), including adjustment of user controls or programming. These costs are the responsibility of the Kramer dealer from whom the product was purchased.
3. Shipping charges.

HOW YOU CAN GET WARRANTY SERVICE

1. To obtain service on you product, you must take or ship it prepaid to any authorized Kramer service center.
2. Whenever warranty service is required, the original dated invoice (or a copy) must be presented as proof of warranty coverage, and should be included in any shipment of the product. Please also include in any mailing a contact name, company, address, and a description of the problem(s).
3. For the name of the nearest Kramer authorized service center, consult your authorized dealer.

LIMITATION OF IMPLIED WARRANTIES

All implied warranties, including warranties of merchantability and fitness for a particular purpose, are limited in duration to the length of this warranty.

EXCLUSION OF DAMAGES

The liability of Kramer for any effective products is limited to the repair or replacement of the product at our option. Kramer shall not be liable for:

1. Damage to other property caused by defects in this product, damages based upon inconvenience, loss of use of the product, loss of time, commercial loss; or:
2. Any other damages, whether incidental, consequential or otherwise. Some countries may not allow limitations on how long an implied warranty lasts and/or do not allow the exclusion or limitation of incidental or consequential damages, so the above limitations and exclusions may not apply to you.

This warranty gives you specific legal rights, and you may also have other rights, which vary from place to place.

NOTE: All products returned to Kramer for service must have prior approval. This may be obtained from your dealer.

This equipment has been tested to determine compliance with the requirements of:

| | |
|-----------|---|
| EN-50081: | "Electromagnetic compatibility (EMC); generic emission standard. Part 1: Residential, commercial and light industry" |
| EN-50082: | "Electromagnetic compatibility (EMC) generic immunity standard. Part 1: Residential, commercial and light industry environment". |
| CFR-47: | FCC* Rules and Regulations: Part 15: "Radio frequency devices Subpart B Unintentional radiators" |

CAUTION!

- ⊗ Servicing the machines can only be done by an authorized Kramer technician. Any user who makes changes or modifications to the unit without the expressed approval of the manufacturer will void user authority to operate the equipment.
- ⊗ Use the supplied DC power supply to feed power to the machine.
- ⊗ Please use recommended interconnection cables to connect the machine to other components.

* FCC and CE approved using STP cable (for twisted pair products)



For the latest information on our products and a list of Kramer distributors, visit our Web site: www.kramerelectronics.com, where updates to this user manual may be found. We welcome your questions, comments and feedback.



Caution

Safety Warning:

Disconnect the unit from the power supply before opening/servicing.



Kramer Electronics, Ltd.

Web site: www.kramerelectronics.com

E-mail: info@kramerel.com

P/N: 2900-000525 REV 1