

**TECHNICAL MANUAL**

**OLCT IR**

**INFRARED DETECTOR  
FOR FLAMMABLE GASES OR  
CO<sub>2</sub>**



Part Number : NPOIRGB  
Revision : F

**OLDHAM**  
The Fixed Gas Detection Experts





## GAS DETECTION

Thank you for purchasing an **OLDHAM** instrument. We appreciate your business.

We trust that our commitment to the technical excellence of our products will ensure your complete satisfaction.

Please read the following document carefully.

### LIMITATION OF LIABILITY

- \* **OLDHAM** will not be liable under any circumstances for material losses, personal injury or death resulting in whole or in part from the inappropriate use of this equipment, the installation or storage of this equipment not in conformance with the instructions and warnings presented in this manual and/or not in conformance with current standards and regulations.
- \* **OLDHAM** neither condones nor authorizes any other company, individual or legal entity to make any claims as to the liability of **OLDHAM**, even if said company, individual or legal entity is directly involved in the sale of **OLDHAM** products.
- \* In no event will **OLDHAM** be liable for any direct or indirect damage including those resulting from the sale and the use of its products **IF THOSE PRODUCTS WERE NOT SPECIFIED AND SELECTED BY OLDHAM FOR SUCH USE.**

### OWNERSHIP CLAUSES

- \* The images, blueprints, specifications and information contained in this document belong to **OLDHAM**.
- \* This information may not be physically, electronically or otherwise reproduced, copied, disclosed, or translated, either in part or in whole, or used in the manufacturing or sale of **OLDHAM** equipment, nor for any other reason without prior permission from **OLDHAM**.

### WARNINGS

- \* This document is not contractual. On behalf of its clients, **OLDHAM** reserves the right to modify the technical characteristics of its equipment without notice to improve product performance.
- \* **CAREFULLY READ THIS DOCUMENT BEFORE USING THE PRODUCT:** this document should be carefully read by any individual who has or who will have the authority to use, maintain or repair this equipment.
- \* **Any and all warranties and performance claims will only be valid if the equipment is operated, maintained and repaired in accordance with OLDHAM directives, by OLDHAM personnel or by personnel appointed by OLDHAM.**

### WARRANTY

- \* Five-year return to factory warranty under normal operating conditions on parts and labor; consumable materials excluded (sensors, filters, etc.).

## DISPOSAL

For the preservation, protection and improvement of environmental quality, and for the protection of human health and the prudent and rational utilization of natural resources, the OLCT IR must be disposed of separately from electronic equipment and cannot be disposed of with normal household waste. The user therefore has an obligation to separate the OLCT IR from other waste to ensure that it is recycled safely for the environment. For further details on existing collection sites, contact the local administration or seller of the product.



# CONTENTS

<b>Figure 1</b> .....	0
<b>Figure 2</b> .....	1
<b>Figure 3</b> .....	2
<b>Figure 4</b> .....	3
<b>Figure 5</b> .....	4
<b>1. INTRODUCTION</b> .....	<b>6</b>
<b>2. TECHNICAL SPECIFICATIONS<sup>(1)</sup></b> .....	<b>8</b>
2.1 INTERFERENCE OF COMMON GASES ON OLCT IR (CH <sub>4</sub> AND HC) .....	9
<b>3. INSTALLATION</b> .....	<b>12</b>
<b>4. START UP</b> .....	<b>12</b>
<b>5. MAINTENANCE</b> .....	<b>14</b>
5.1 CORRECTIVE MAINTENANCE .....	14
5.2 PERIODIC MAINTENANCE .....	14
<b>6. LIST OF ACCESSORIES</b> .....	<b>18</b>
<b>7. SPECIAL INSTRUCTIONS FOR USE IN ATEX EXPLOSIVE ATMOSPHERES AND FOR FUNCTIONAL SAFETY</b> .....	<b>20</b>
7.1 USE IN ATEX EXPLOSIVE ATMOSPHERES .....	20
7.2 FUNCTIONAL SAFETY .....	21
<b>8. MARKING:</b> .....	<b>22</b>
<b>9. MANUFACTURER'S DECLARATION OF CONFORMITY</b> .....	<b>24</b>





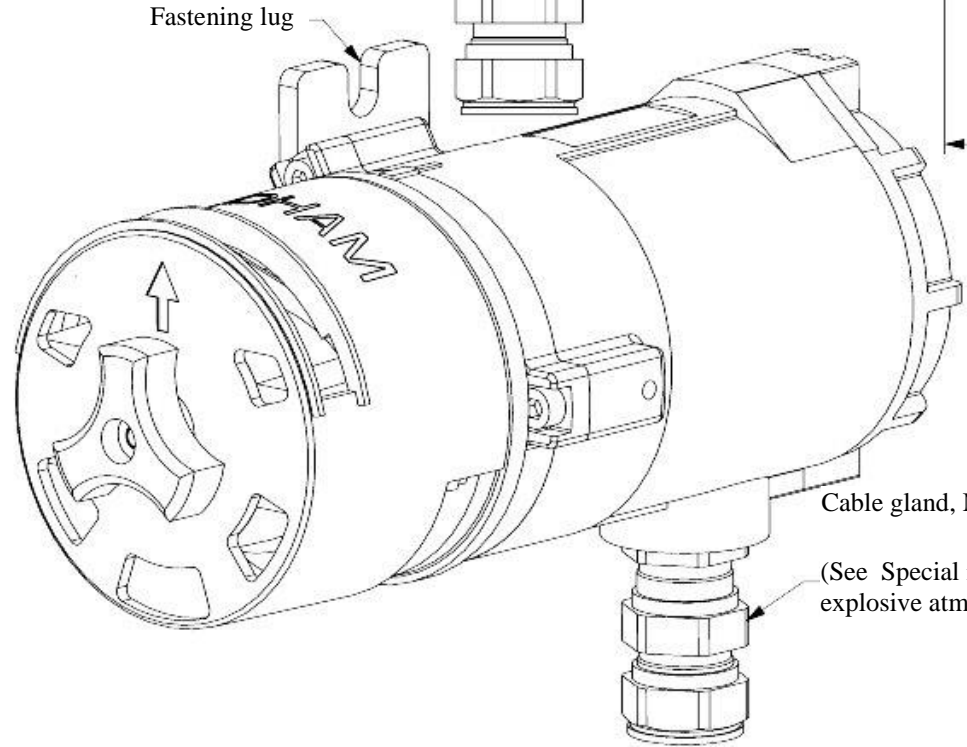
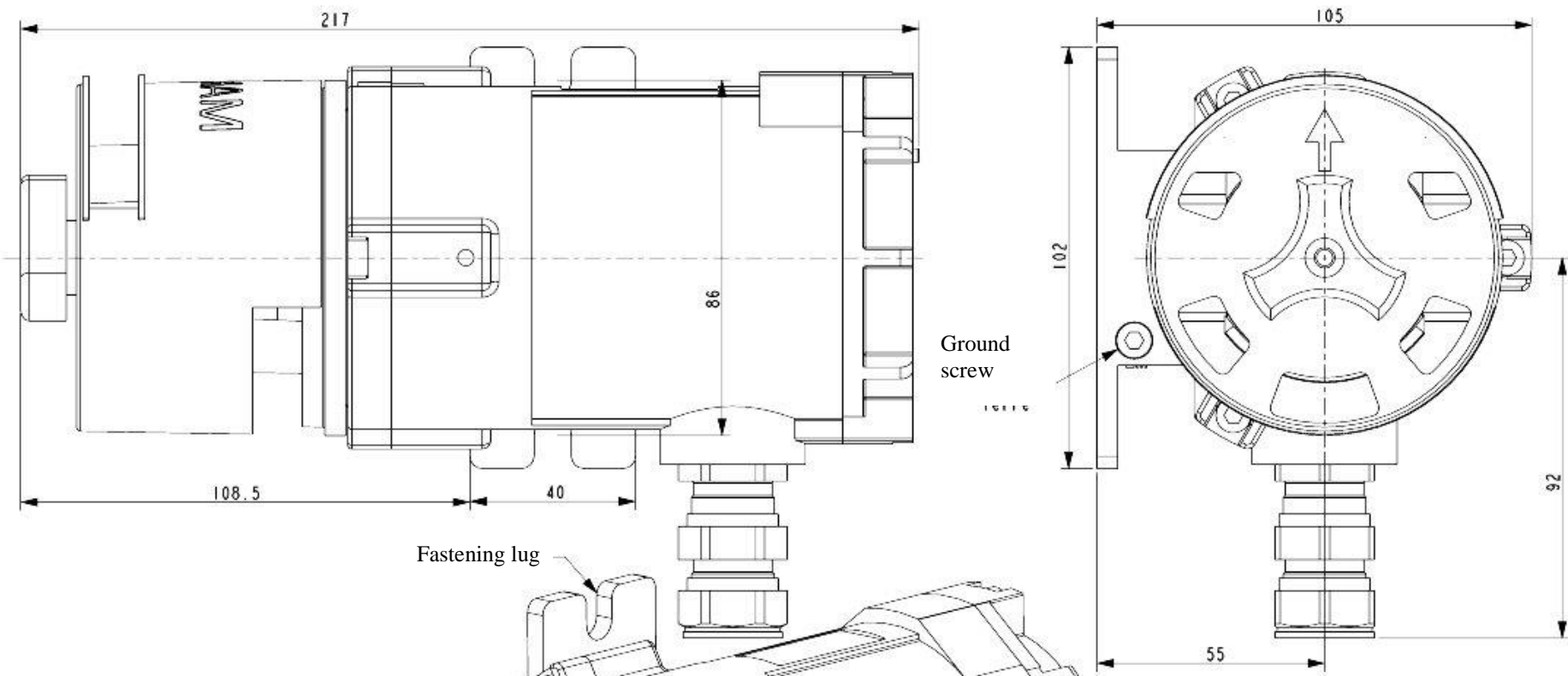

Fastening lug

Ground screw

Cable gland, M20x1.5, optional

(See Special instructions for use in ATEX explosive atmospheres)

**Figure 1**  
**OLCT IR**  
 with weather protection



REP	NBR	DESIGNATION	REF OFSA
1	1	WEATHER PROTECTION	6313862
2	1	O-RING DIA. DIAM=65x3	6136242
3	1	LOCKING NUT M5	6903376
4	1	TERMINAL COVER	6123723
6	2	Ex TERMINAL	6152989
7	1	O-RING DIA DIAM=69x2	6135036
8	1	LED PCB	6451495

OPTION

5	1	CABLE GLAND, M20, ARMOURED CABLE OR CABLE GLAND, M20, NON-ARMOURED CABLE	6343489 6343493
---	---	---	--------------------

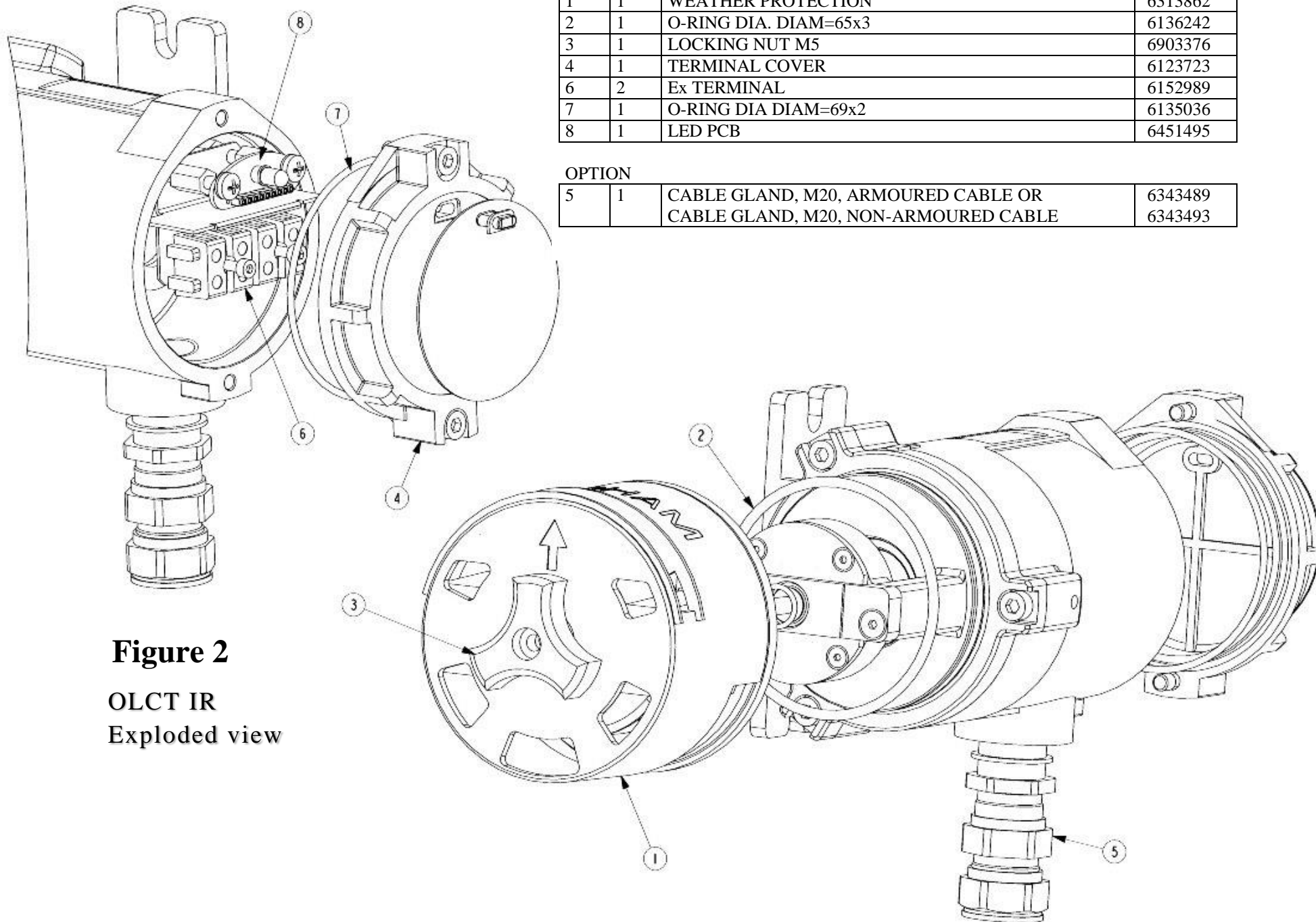
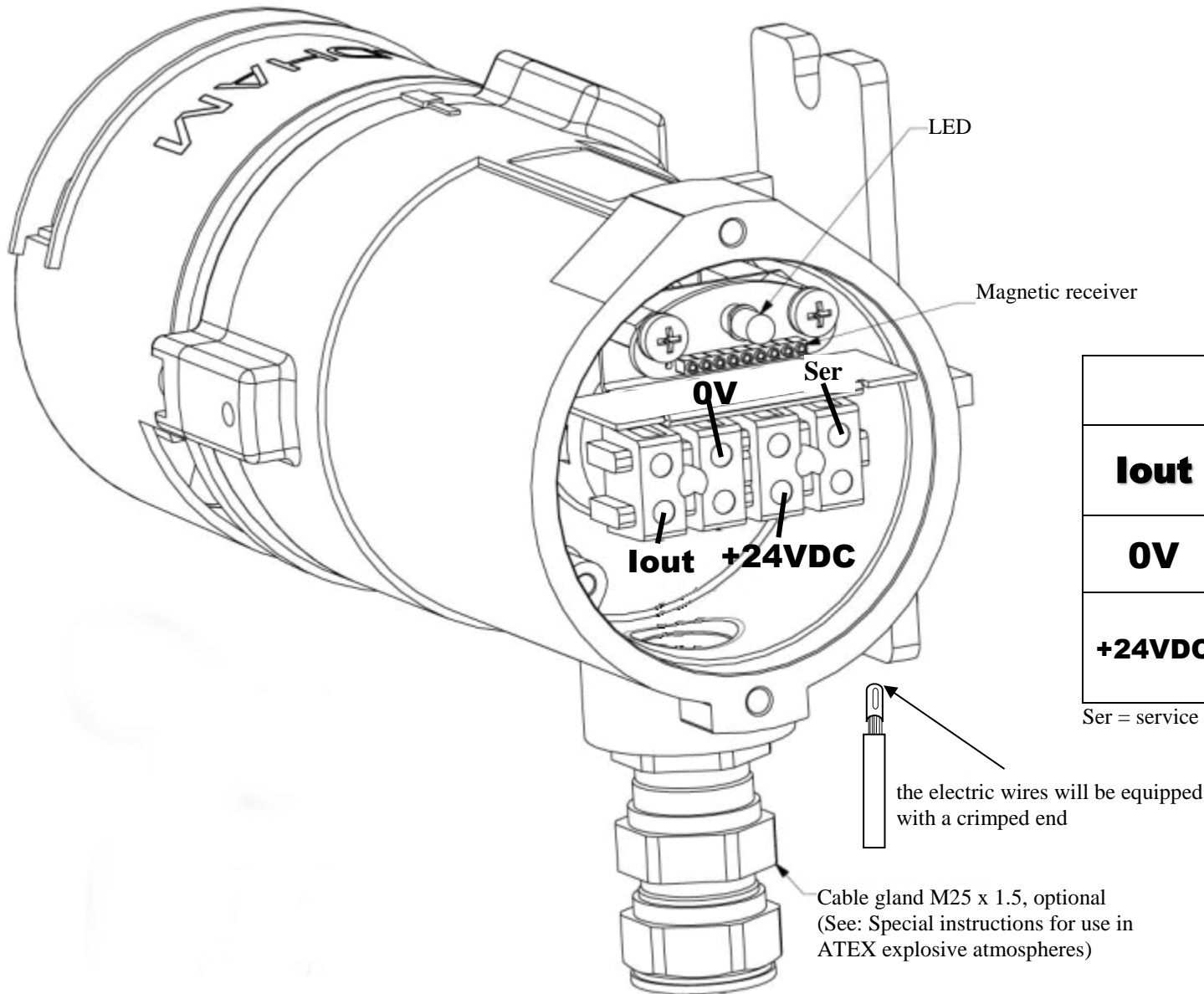

**Figure 2**

OLCT IR  
Exploded view

**Figure 3**

**OLCT IR  
Terminal block**



Connection	
<b>lout</b>	Output signal in mA (terminal 1 of OLDHAM central units)
<b>0V</b>	Power supply 0 V (terminal 2 of OLDHAM central units)
<b>+24VDC</b>	Power supply + (terminal 3 of OLDHAM central units)

Ser = service (do not use)

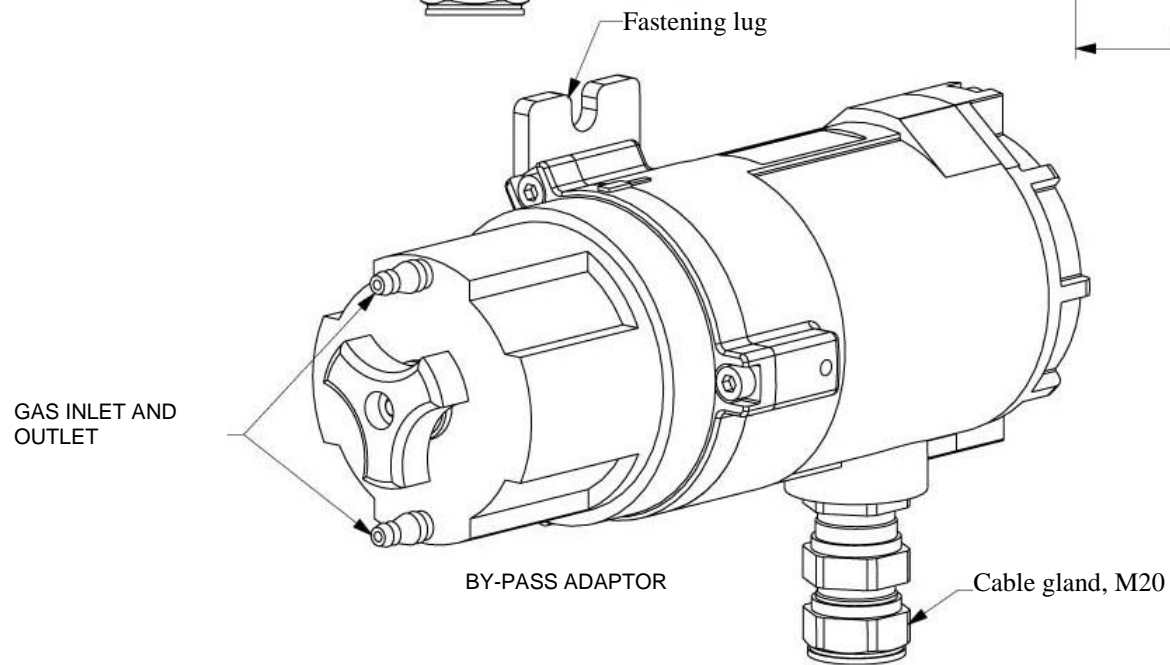
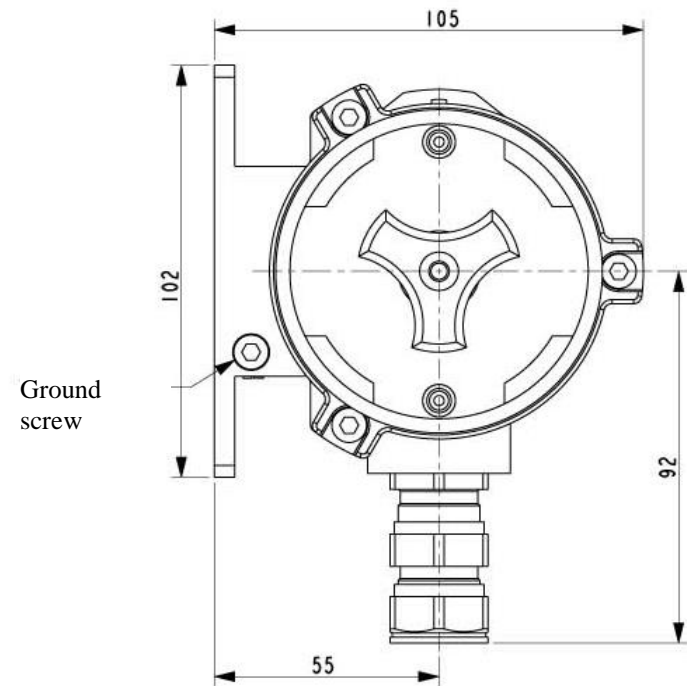
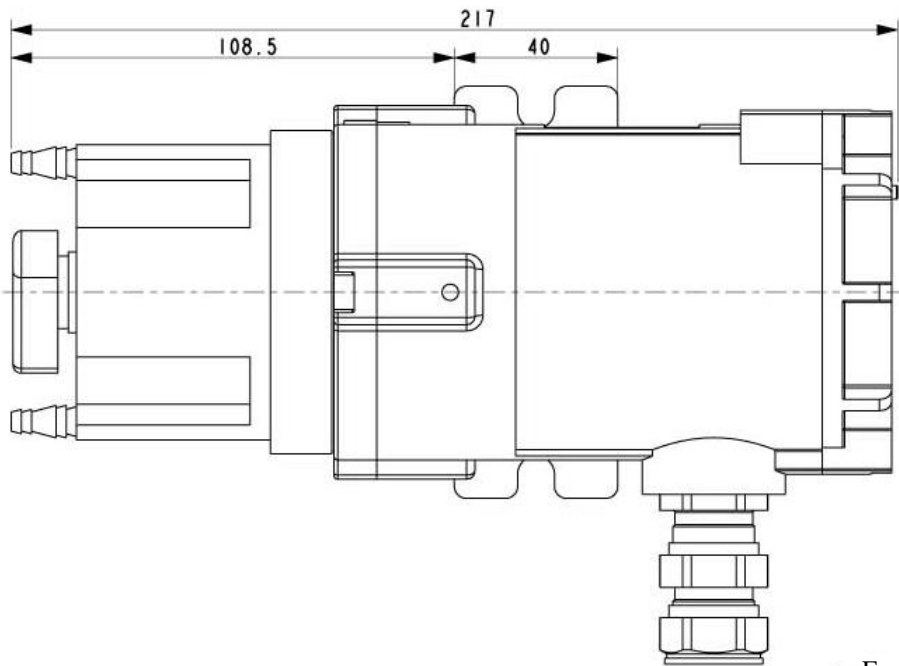

**Figure 4**  
OLCT IR  
with by-pass adaptor  
(calibration cup)

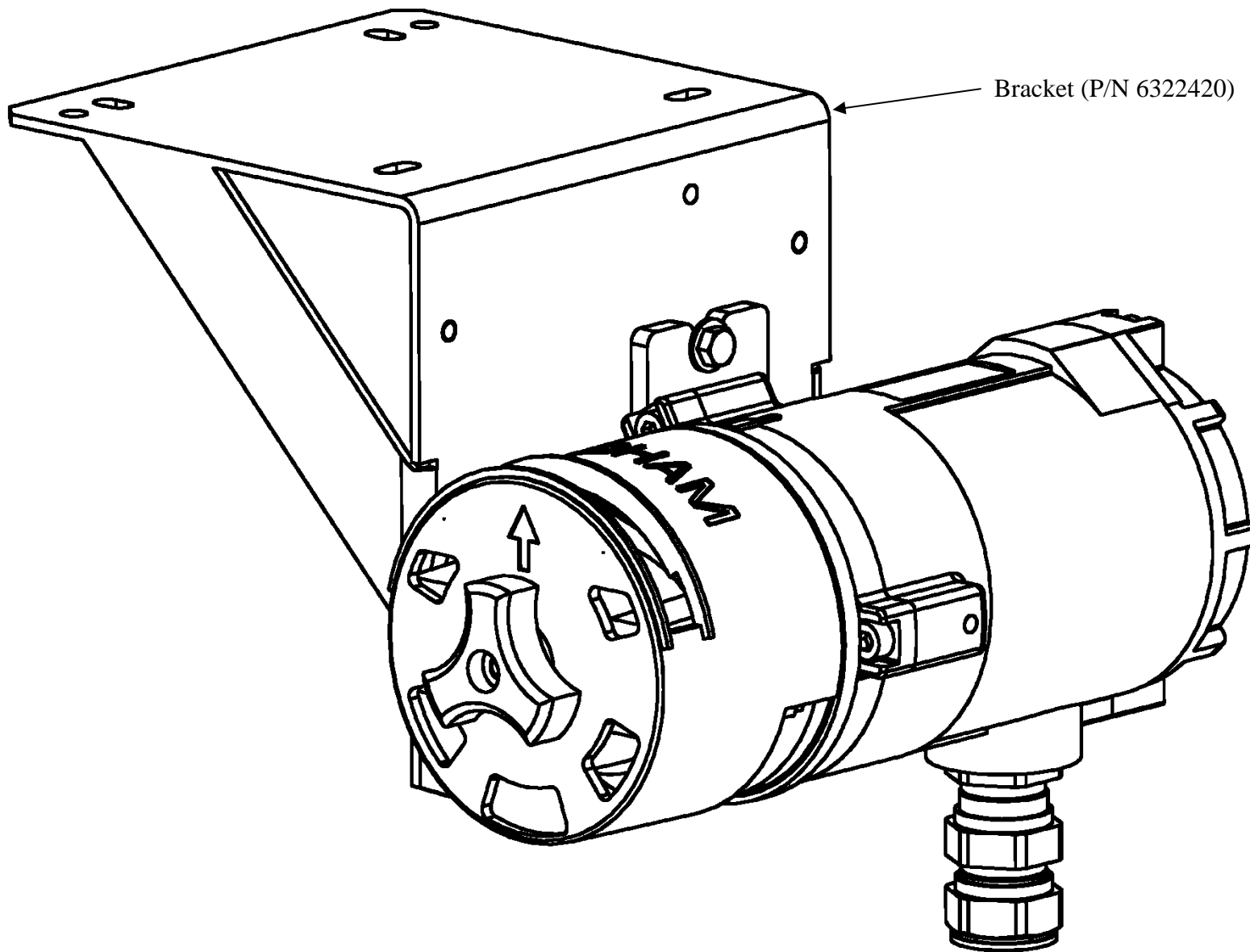

**Figure 5**  
Ceiling mount for OLCT IR

|

# 1. INTRODUCTION

The **OLCT IR** gas detector is designed to monitor flammable gases or CO<sub>2</sub> concentrations in the ambient air. The infrared technology used by the OLCT IR guarantees extreme detection accuracy.

Powered with 24 Vdc, the OLCT IR provides a standard 4-20 mA analog output which is proportional to the measured concentration of gas. It features a non-intrusive calibration that enables calibration in hazardous area without declassifying the zone.

The OLCT IR detector can be used in gas and dust explosive atmospheres and meets all of the essential requirements of the ATEX 94/9/EC European Directive and following European EN and international IEC standards:

- EN 60079-0:2012                      IEC 60079-0 (ed.6):2011
- EN 60079-1:2007                    IEC 60079-1 (ed.6):2007
- EN 60079-7:2007                    IEC 60079-7 (ed.4):2006
- EN 60079-11:2012                  IEC 60079-11 (ed.6):2011
- EN 60079-31:2014                  IEC 60079-31 (ed.2):2013

## Company label

The enclosure has two identifier labels, as described below

id.	Description
1.	Manufacturer's name
2.	Type of product
3.	ATEX- IECEx Marking
4.	CE symbol and the number of the organisation that provided the OLDHAM production quality certification (INERIS )
5.	Warning.
6.	Maximun ATEX certification temperature (excluding metrological performance)
7.	Recycling symbol
8.	Detector serial number (S/N). The first two digits (in this case 09) correspond to the year of manufacture (in this case 2009)
9.	Thread diameter and pitch for cable inlet

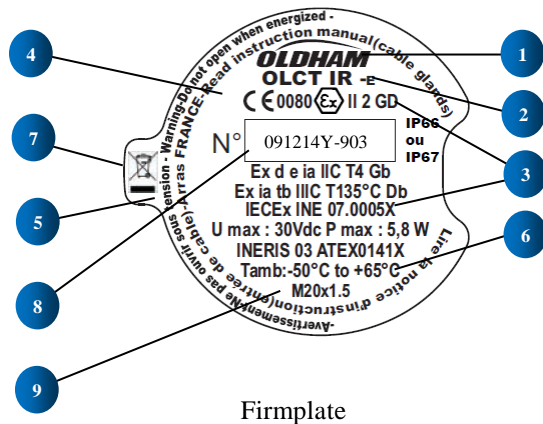

The OLTC IR is available in various configurations:

**Methane Version (CH<sub>4</sub>):**

- % LEL: optimized for methane detection, standard range is 0-100% LEL (0-5% vol.). The range can be adjusted to 0-4.4% vol. for those who consider this value as the lower explosive limit for methane.
- % Vol.: detection of methane from 0 to 100% vol.

**HC Version:**

- Optimized for the detection of saturated hydrocarbons (propane, butane, pentane, hexane, ethanol, etc.). The standard range is set in factory:
  - C<sub>3</sub>H<sub>8</sub> – 0 to 100% LEL
  - C<sub>4</sub>H<sub>10</sub> – 0 to 100% LEL
  - C<sub>2</sub>H<sub>6</sub>O – 0 to 100% LEL
  - C<sub>6</sub>H<sub>14</sub> – 0 to 100% LEL

**CO<sub>2</sub> Version:**

- Optimized for CO<sub>2</sub> detection from 0 to 3% vol.

## 2. TECHNICAL SPECIFICATIONS<sup>(1)</sup>

Detection method	Infrared absorption
Gases detected <sup>(3)</sup> (set in factory)	Methane, Propane, Butane, Hexane, Ethanol <sup>(2)</sup> CO <sub>2</sub>
Range (typical)	100% LEL CH <sub>4</sub> , C <sub>3</sub> H <sub>8</sub> , C <sub>4</sub> H <sub>10</sub> 100% volume CH <sub>4</sub> 3% volume CO <sub>2</sub>
Accuracy	+/-3% LEL CH <sub>4</sub> or +/- 5 % of measurement +/-2% LEL HC or +/- 3 % of measurement
Long term stability at operating temperature from -25°C to +55°C	zero: +/-1 LEL gain : +/-5% LEL or +/- 10% of measurement
Response time without weather protection with weather protection	T50 < 7 seconds - T90 < 8 seconds T50 < 10 seconds - T90 < 16 seconds
Voltage	16 to 30 VDC
Average Consumption	2.5 W typical (max intermittent current = 500 mA)
Signal Output	Source signal encoded from 0 to 25 mA (non-isolated): 4 to 20 mA: linear and proportional to gas measurement 0 mA: electronic fault or power loss 0.5 mA: dirty optics, temperature is out of specification 1 mA: detector fault 2 mA: calibration mode > 23 mA: out of range
Wiring	3-wire shielded cable
Load resistance (with OLDHAM controller)	8 Ohm in loop (250 meters with 1.5 mm <sup>2</sup> core size cable)
Max. output load resistance	300 Ohm
Cable entry	M20 x1.5 (cable gland in option, See special instructions for use in ATEX explosive atmospheres )
Cable diameter	Armoured cable: Outer diameter 8.5 to 16 mm Inner diameter 6 to 12mm Unarmoured cable: Inner diameter 6 to 12mm
Operating Temperature	-25°C to 55°C by default (-50°C to +55°C available upon request)
Storage temperature:	-50°C to 55°C
Electromagnetic Compatibility	Complies with EN 50270:06 Types 1 and 2
IP Rating	IP 66 – IP 67
ATEX	Complies with the European Directive ATEX 94/9/EC and IEC Ex Scheme (see attached declaration)
Weight	1.6 Kg
Materials	INOX 316L
Humidity	0 to 99% RH (noncondensing)
Pressure influence	Measurement: partial pressure

(1) Due to the continual improvement of our products, **OLDHAM** reserves the right to modify the product specifications listed in this document at any time.

(2) The majority of organic components comprising C-H bonds

(3) Hydrogen is not detected. Saturated hydrocarbons are more sensitive than CH<sub>4</sub> (typically 5 to 7 times more), while Unsaturated and Benzenic Hydrocarbons are less sensitive than CH<sub>4</sub>.

**Warning: Acetylene and Ammonia have a negative cross sensitivity on the measurement. Above 2,000 ppm acetylene or 10,000 ppm ammonia, the presence of other gases may be masked.**



## 2.1 Interference of common gases on OLCT IR (CH<sub>4</sub> and HC)

Any organic molecule with at least one C-H bond except for acetylene can potentially be detected by the OLCT IR, though the sensitivity varies.

Note the following:

- Regardless the detector version, saturated hydrocarbons give a greater response than CH<sub>4</sub>;
- The OLCT IR CH<sub>4</sub> is more sensitive to CH<sub>4</sub> and less sensitive to hydrocarbons than the OLCT IR HC;
- With regards to the OLCT IR CH<sub>4</sub>, a signal of 20mA corresponds to 100% LEL CH<sub>4</sub> or 20% LEL C<sub>3</sub>H<sub>8</sub> (factor 5);
- With regards to the OLCT IR HC, a signal of 6.4mA signals corresponds to 100% LEL CH<sub>4</sub> or 14% LEL C<sub>3</sub>H<sub>8</sub> value (factor 7);
- The OLCT IR HC is usually more suitable for the detection of saturated molecules such as alkanes, alcohols, ketones, organic acids, esters and ethers.
- The OLCT IR CH<sub>4</sub> is usually more suitable for the detection of unsaturated hydrocarbons such as alkenes and aromatics with H-C bonds although they give less signal than CH<sub>4</sub>

As an example, see below the response curves for common HCs (accuracy is +/-15 %).

- **OLCT IR CH<sub>4</sub>**

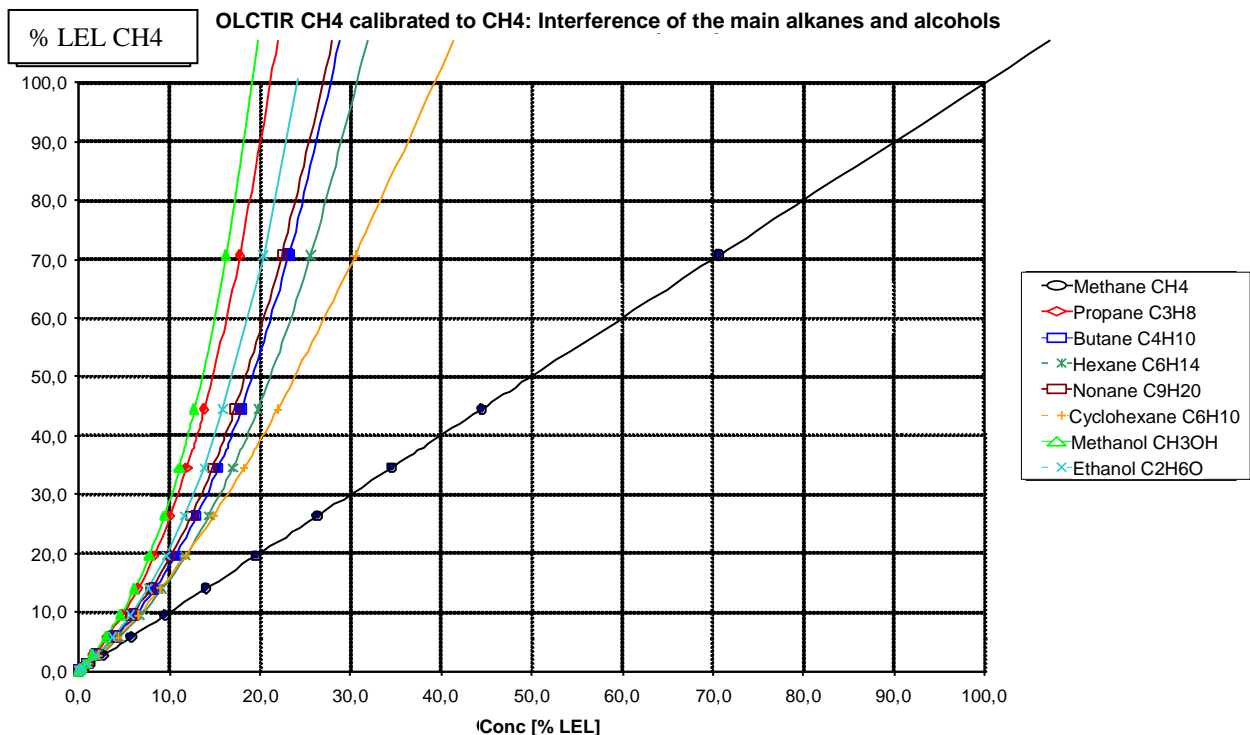

- OLCT IR HC (propane calibration)

% LEL C3H8

OLCT IR HC calibrated to C3H8 : Interference of the main alkanes & alcohols

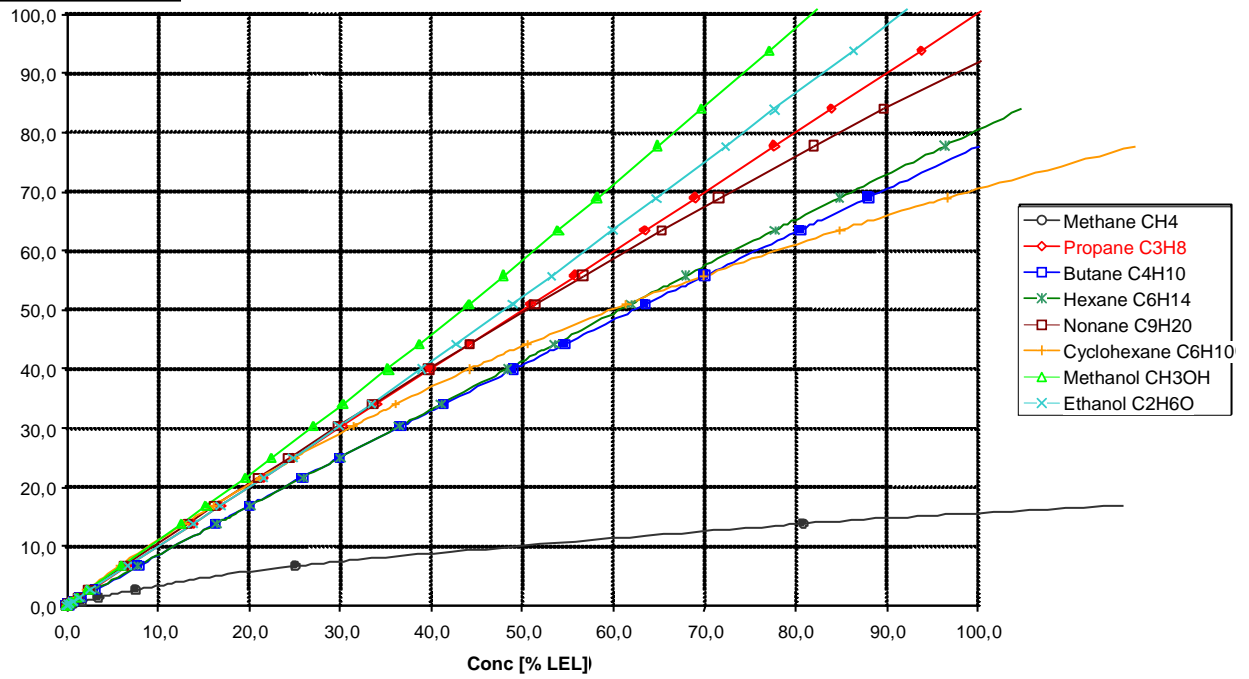



### 3. **INSTALLATION**

**WARNING:** Before proceeding refer to paragraph #7, “Specific Instructions for Assembly in Explosive Atmospheres”.

#### **Safety Precautions**

The detector must be installed in an appropriate location to enable optimal protection.

The OLCT IR **shall be mounted horizontally so that the arrow on the weather protection looks upward.** If mounted incorrectly, the OLCT IR detector may not be able to detect gases or vapors in the air.

#### **Mechanical installation**

- Follow carefully the safety instructions outlined above
- Look at figures 1 and 4 for the dimensions of the OLCT IR
- The OLCT IR detector is intended to be mounted on a vertical support structure, such as a wall. When it has to be mounted on a horizontal surface, use the ceiling mount (part number 6322420, see Fig. 5).

#### **Electrical installation**

- Ensure that the installation complies with currently enforced standards, EN/IEC 60079-14, EN/IEC 60079-17 standards, zone classification, and all other enforced editions or national standards.
- To ensure proper operation of the detector, the cable resistance must remain within the limits specified in the technical specifications table.
- Make sure the power supply at detector terminals is between 16 and 30 VDC
- Remove the weather protection (see Rep. 4, Fig. 2) to access the terminal block
- Connect the 3 active wires as shown in Fig. 3
- Replace the protective cover
- Ground the detector casing (Fig. 1)

### 4. **START UP**

- Verify that all equipment connections and installations have been performed correctly.
- To avoid false alarms, inhibit the controller or the PLC.
- Power up the OLCT IR and wait 2 or 3 minutes for stabilization (during warming-up, the signal output is set to 2 mA)
- Check the zero (4 mA) and gas response. When zeroing a CO<sub>2</sub> version, apply nitrogen.



## 5. MAINTENANCE



Warning: Operations described in this paragraph are reserved for authorized and trained people otherwise the safety of the installation may be impaired.

**Do not open the OLCT IR housing** since it contains an inert gas. If the detector has been opened, it shall be returned to factory for repair.

Inspection and maintenance operations must be conducted in accordance with EN60079-17 or IEC 60079-17 (edition in force) or any other domestic standards.

**The OLCT IR is designed to require minimal maintenance.**

**The maintenance is limited to the regular inspection of the detector head.**

### 5.1 Corrective maintenance

Optical surfaces only need to be cleaned in the event of an optical disturbance (output current of 0.5 mA) or signal drift:

- remove the weather protection (Rep. 1 Fig. 2)
- clean the optical surfaces with a soft, lint-free cloth and isopropanol alcohol
- if necessary, clean the optional bug guard and the protective cover
- let dry
- place the weather protection back and make sure the arrow looks upward

### 5.2 Periodic maintenance

Gas detectors are safety devices. OLDHAM recommends the regular testing of fixed gas detection installations. This type of test consists of injecting the standard gas into the detector at a sufficient concentration to activate the pre-set alarms.

The frequency of gas tests depends on the industrial application in which the detector is in use. Frequent inspections should be made in the months following the commissioning of the installation, and then become more widely spaced provided that no significant deviation is observed. The interval between tests should not exceed 12 months. If a detector should fail to react when in contact with the gas, calibration is essential.

**The site manager should put safety procedures in place on-site. OLDHAM cannot be held responsible for their enforcement.**

## Verification

### ➤ Required equipment

- gas calibration kit (calibration gas cylinder and its accessories)
- bump test cup (P/N 6313829)

### ➤ Procedure

- place the test cup over the weather protection and inject the calibration gas at a flow rate of 2 liters per minute. Check the measurement is within +/-10% of the calgas concentration and check the alarms.

## Calibration

### ➤ Required equipment

- gas calibration kit (calibration gas cylinder and its accessories). The calibration gas that shall be used is indicated on the detector.
- magnetic wand (P/N 6155651) for maintenance call and settings
- calibration cup (P/N 6313863)

### ➤ Preparation

- set the controller in maintenance mode (so that the relays are inhibited)
- remove the screw (Rep. 3, Fig. 2) and remove the protective cover
- place the calibration cup as shown in Fig. 4
- connect the calibration tube to one gas inlet of the calibration cup

### ➤ Procedure

Calibration is usually limited to zero adjustment. Sensitivity adjustment should be performed on very rare occasion. Use the magnetic wand and follow the indications given by the red LED (Rep. 8, Fig. 2) according to the instructions on the next page.

- adjust the zero in a gas-free environment
- if clean air is not available, inject nitrogen or grade air at a flow rate between 1 and 2 liters per minute to ensure that the zero is properly adjusted; for CO<sub>2</sub> version, inject nitrogen (1 to 2 l/min.).
- follow the instructions as shown in the diagram on next page
- once the procedure is completed, stop injecting gas and replace the protective cover with the arrow looking upward
- set back the controller in normal operation mode (so that the relays are no longer inhibited).

**WARNING:** During the calibration, the security function is no guaranteed and the output current is blocked at 2mA up to the end of the procedure.

For calibration, it is imperative to use the calibration gas indicated on the detector. Some versions cannot be calibrated in the field because appropriate calibration gas is just not available ('gasoline' for example). In this case, carry out a test by using an interferent gas. On the calibration certificate attached with the detector is written the nature of the test gas and the expected response of the detector to this gas.

**Normal operation**

I out: measurement current  
(4 to 20 mA)  
LED: Off

Fast sweep of the magnet

**Calling up the calibration procedure**

I out: 2 mA  
LED: Slow flash

Slow sweep of the magnet

Exit from procedure  
without action

**Zero setting:**

Inject nitrogen on the OCLT IR

Note: Waiting time for the zero to stabilise  $\approx 20$  s

I out: 2 mA  
LED: Moderate flash

Slow sweep of the magnet

Exit from procedure  
without action

Fast sweep of the magnet

**Validation of the zero and switch to sensitivity setting**

I out: 2 mA  
LED: Slow flash

**Abort sensitivity setting**

Slow sweep of the magnet

Exit from procedure  
with zero validation

**OR**

**Continue with sensitivity adjustment** (inject the calgas concentration as indicated on the OLCT IR housing)

Note: Waiting time for the value to stabilise  $\approx 90$  s

I out: 2 mA  
LED: Moderate flash

**Validation of sensitivity?**

NO =  
Slow sweep of the magnet

Exit from procedure with  
zero validation

YES =  
Fast sweep of the magnet

- I out: depending on the measurement or faults  
LED: Off







**Index:**

- Magnet Movement: Action of moving the magnet in front of the magnetic receptor located near the red LED (Fig. 3).
- Fast movement: < 1second.
- Slow movement: > 1second and until you exit the procedure exit (red LED off).
- I out : signal output current.
- LED: red, off or blinking.

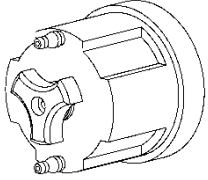
**Note:** the interval between each action cannot exceed 10 minutes or the procedure will be canceled and the equipment will return to normal operation mode.

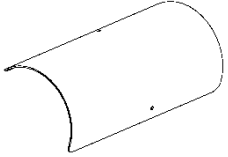
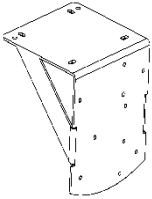
## 6. LIST OF ACCESSORIES

Accessories	Part No.	
By-pass adaptor / Calibration cup	6313863	
Bump test cup	6313829	
Service magnet	6155651	
Sunshield (can also be used to prevent snow from clogging the openings)	6313858	
Ceiling mount (bolts not included)	6322420	
Weather protection (protective cover)	6313862	
Thumbscrew (M5 D40)	6903376	
Mosquito guard	6313946	

Refer to Figures 2 and 4



## **7. Special instructions for use in ATEX explosive atmospheres and for functional safety**

### **7.1 Use in ATEX explosive atmospheres**

Generally, ambient temperature, voltage supply and power mentioned below relate to safety against explosion. These parameters are not metrological data (refer to the technical characteristics table).

- **Conformity to European Harmonized EN standards and to international IEC standards:**

The OLCT IR complies with the following standards:

Protection against explosion:

EN 60079-0:2012	IEC 60079-0 (ed.6):2011
EN 60079-1:2007	IEC 60079-1 (ed.6):2007
EN 60079-7:2007	IEC 60079-7 (ed.4):2006
EN 60079-11:2012	IEC 60079-11 (ed.6):2011
EN 60079-31:2014	IEC 60079-31 (ed.2):2013

**Performance standards (metrology) for Methane and Propane:**

OLCT IR detectors conform to EN 61779-1:2000 and EN 61779-4:2000 standards, Suitability requirements for the operation of flammable gas detectors, category 0 to 100% LEL Group II, reference gas 0-100% LEL Methane and Propane.

These detectors are classed as safety devices according to ATEX 94/9/CE Directive and may, therefore, contribute to limiting the risks of explosion. For this to be so, they must be connected to Oldham type MX 15, MX 32, MX 42A, MX 48, MX 43, MX 52 or MX 62 detection controllers, or otherwise connected to measurement systems with 4-20 mA inputs conforming to section 1.5 of Annex II of ATEX Directive 94/9/CE and compatible with their characteristics (see transfer curve).

**Electromagnetic Compatibility:**

EN 50270:2006 Typ 1 and 2

- **Operating Zones:**

the equipment is authorized for use in zones 1, 2, 21 and 22 for ambient temperatures between -50°C to + 65°C (Note that the maximum functioning temperature is +55°C).

- **Installation:**

**Orientation:** the OLCT IR detector must be installed horizontally, with the arrow on the protective cover looking upward.

**Cable entry:** the cable gland used shall be IP 66 or IP 66/67 certified according to EN 60529 or IEC 60529, M20 x1.5 typ and match with the detector operating temperature. It shall be increased safety certified ('e') for use in explosive atmospheres and will be mounted according to IEC/EN 60079-14 standard, edition in force, and to additional requirements from local standards

- **Wiring/ Connections:**

Wiring must comply with existing standards about installations in explosive atmospheres, especially IEC/EN 60079-14 and IEC/EN 60079-17 standards. Cables must be protected against mechanical shocks.

When conductors are connected to the terminal, the distance between live components and grounded metallic parts must be greater than 2.5mm.

- **Grounding:**

The detector must be connected to the ground via its external ground connection (see Fig. 1). This connection must be protected against corrosion.

- **Power supply:**

Voltage at detector terminals = 30 VDC max, 16 VDC min.

Max power = 5.8 Watts

- **Replacing screws:**

If you need to replace a screw from the “Ex d” flameproof housing, use an A4.70 or a screw of higher quality.

- **Dusty atmospheres:**

When using the equipment in dust explosive atmospheres, the equipment should be thoroughly cleaned on a regular basis to prevent dust buildup. The dust layer shall be less than 5 mm thick. The joints between the housing and the sensor part or between the housing and the terminal block cover will be coated with paraffinic grease.

- **Transfer curve and power supply parameters**

The following curve shows the OLCT IR current output value depending on the gas concentration, special maintenance and fault states. In the event the user connects the transmitter to a non-OLDHAM controller, the user must ensure that the OLTC IR transfer curve is compatible with the controller input characteristics in order to read properly the signal from the transmitter.

In addition, the controller should provide a power supply of 16 to 32 VDC at detector terminals, with intermittent peaks at 500 mA.

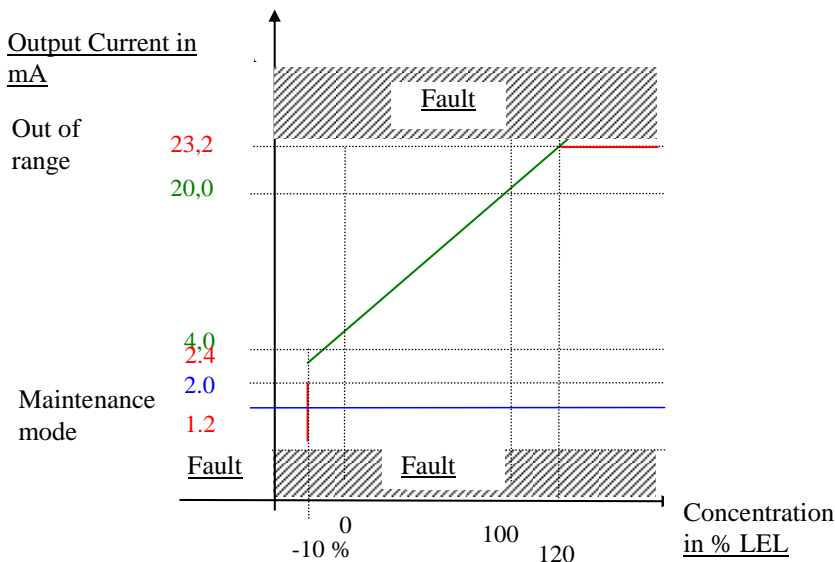

## 7.2 Functional Safety

The detector OLCTIR (CH4 and HC versions) has been certified by INERIS as SIL 2 capable according to EN 50402 (Certificate INERIS 03ATEX0141X/02). This standard applies since 2005 and defines the requirements on the functional safety of fixed gas systems (electrical apparatus for the detection and measurement of combustible or toxic gases or vapours or of oxygen).

The detector OLCT IR was designed in conformity with IEC 61508 standard.

The safety function of the OLCT IR is to detect combustible gases with infrared absorption technology and to deliver a 4-20mA current output proportionally to the gas concentration as a percentage of the LEL, respectively from 0 to 100% LEL. In fault mode, the output will be less than or equal to 1 mA or greater than or equal to 23mA.

Maintenance Interval Test	$\lambda_{DU}$	$PFD_{avg}$	SFF	DC	SIL capability
1 year	$3.5 \cdot 10^{-7}$	$1.6 \cdot 10^{-3}$	90%	72.3%	2

$\lambda_{DU}$ : Failure Rate per hour (dangerous undetected)

$PFD_{avg}$ : Probability of Failure on Demand

SFF: Safety Failure Fraction

DC: Diagnostic Cover ge (fraction between dangerous failures rate and total failures rate).

## 8. Marking:

### OLCT IR Markings

See the firm plate on the terminal block cover. The marking must include the following information:

- On the terminal block cover

**OLDHAM**  
CE0080  
OLCT IR -E

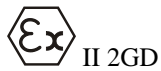

Ex d e ia IIC T4 Gb  
Ex ia tb IIIC T135°C Db IP66

T<sub>amb</sub>: -50 °C to 65 °C

U max: 30 V

P max.: 5.8 W

M20 x 1.5

IECE<sub>x</sub> INE 07.0005X

INERIS 03ATEX0141X

(Serial Number)

(Year of Manufacture)

AVERTISSEMENT:

Ne pas ouvrir sous tension – Lire la notice d’instruction (entrée de câble)

WARNING :

Do not open when energized – Read instruction manual (cable glands)

- Near the mirror

Ex e IIC T4 Gb

U max: 30V

P max: 0.875W



## 9. Manufacturer's Declaration of Conformity



### Déclaration de Conformité CE EC Declaration of Conformity



La Société Oldham S.A.S., Z.I. Est, 62000 Arras France, atteste que la :  
The Company Oldham S.A.S., Z.I. Est, 62000 Arras France, declares that:

#### Détecteur de gaz OLCT IR *Gas detector OLCT IR*

est conforme aux exigences des Directives Européennes suivantes:  
complies with the requirements of the following European Directives:

#### I) Directive Européenne ATEX 94/9/CE du 23/03/94: Atmosphères Explosives

*The European Directive ATEX 94/9/CE of 23/03/94: Explosive Atmospheres*

Normes appliquées  
*Applied standards*

**EN 61779-1:00** Exigences d'aptitude à la fonction des détecteurs de gaz inflammables

*Performance requirements of detectors for flammable gases*

**EN 61779-4:00** Règles de performance des appareils du groupe II pouvant indiquer une fraction volumique jusqu'à 100 % LIE

*Performance requirements for group II apparatus indicating a volume fraction up to 100%LEL*

**EN 50271:01** Appareils de détection de gaz utilisant un logiciel et/ou des technologies numériques

*Apparatus for the detection of gases using software and/or digital technologies*

Normes harmonisées appliquées  
*Harmonised applied standards*

**EN 60079-0:12** Protection du matériel-règles générales

*Equipment protection-general requirements*

**EN 60079-1:07** ('d') / **EN 60079-31:14** ('t')

**EN 60079-7:07** ('e') / **EN 60079-11:12** ('i')

Catégorie(Category)/Marquage(marking)

**OLCT IR E** (-50 °C<Ta<+65 °C)



**II 2 GD**

**Ex d e ia IIC T4 Gb / Ex ia tb IIIC T135°C Db IP66**

Attestation CE de Type du matériel  
*EC type examination certificate*

**INERIS 03ATEX0141X**

Notification Assurance Qualité de Production  
*Notification of the Production QA*

**INERIS 00ATEXQ403**

Délivré par l'Organisme notifié numéro 0080  
*Issued by the Notified Body n°0080*

**INERIS, Parc Alata**  
60550 Verneuil en Halatte France

#### II) Directive Européenne CEM 2004/108/CE du 15/12/04: Compatibilité Electromagnétique

*European Directive EMC 2004/108/CEE dated from 15/12/04: Electromagnetic Compatibility*

Norme harmonisée appliquée  
*Harmonised applied standard*

**EN 50270:06** for type2

CEM-Appareils de détection des gaz

*EMC-Apparatus for the detection of gases*

#### Sécurité de Fonctionnement (Safety Instrumented System)

Normes appliquées  
*Applied standards*

**EN 50402:05** Exigences relatives à la fonction de sécurité des systèmes fixes de détection de gaz

*Functional safety of fixed gas detection systems*

Niveau d'intégrité de sécurité  
*Safety Integrity Level*

**SIL2** Certificat (certificate) INERIS 01ATEX 0141X/02 par (by) INERIS

Arras, le 15/02/2015 (Feb. 15<sup>th</sup>, 2015)



**Oldham S.A.S.**  
Z.I. EST - C.S. 20417  
62027 ARRAS Cédex - FRANCE  
www.oldhamgas.com

**Michel Spellemaeker**  
Global Director of Product Management

CE\_ATEX\_OLCT IR\_ind\_j











## **EUROPEAN PLANT AND OFFICES**

Z.I.Est – rue Orfila CS 20417 – 62027 Arras Cedex FRANCE  
Tél: +33 (0)3 21 60 80 80 – Fax: +33 (0)3 21 60 80 00  
Website: <http://www.oldhamgas.com>

AMERICAS  
Tel: +1 713-559-9280  
Fax: +1 281-292-2860  
[americas@oldhamgas.com](mailto:americas@oldhamgas.com)

ASIA PACIFIC  
Tel: +86-21-3127-6373  
Fax: +86-21-3127-6365  
[info@oldhamgas.com](mailto:info@oldhamgas.com)

EUROPE  
Tel: +33-321-608-080  
Fax: +33-321-608-000  
[info@oldhamgas.com](mailto:info@oldhamgas.com)