



User Manual

Read and understand this manual before using machine.

6" GRANITE JOINTER

Model Number
40615 40625



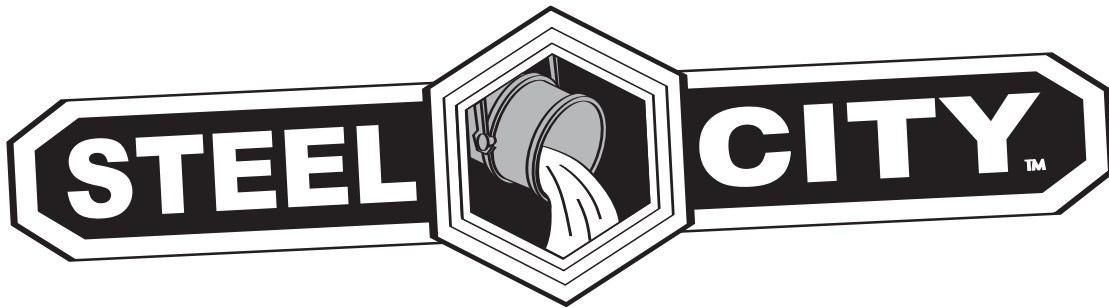

THANK YOU for purchasing your new Steel City Jointer. This jointer has been designed, tested, and inspected with you, the customer, in mind. When properly used and maintained, your jointer will provide you with years of trouble free service, which is why it is backed by one of the longest machinery warranties in the business.

This jointer is just one of many products in the Steel City's family of woodworking machinery and is proof of our commitment to total customer satisfaction.

At Steel City we continue to strive for excellence each and every day and value the opinion of you, our customer. For comments about your jointer or Steel City Tool Works, please visit our web site at www.steelcitytoolworks.com .

TABLE OF CONTENTS

INTRODUCTION

SECTION 1	Warranty	4
SECTION 2	Product Specifications	7
SECTION 3	Accessories and Attachments	7
SECTION 4	Definition of Terms	7
SECTION 5	Feature Identification	8
SECTION 6	General Safety	9
SECTION 7	Product Safety	12
SECTION 8	Electrical Requirements	13
SECTION 9	Grounding Instructions	14
SECTION 10	Unpacking & Inventory	15
SECTION 11	Assembly	18
SECTION 12	Adjustments	23
SECTION 13	Operations	26
SECTION 14	Maintenance	29
SECTION 15	Troubleshooting	31
SECTION 16	Parts List	33

INTRODUCTION

This user manual is intended for use by anyone working with this machine. It should be kept available for immediate reference so that all operations can be performed with maximum efficiency and safety. Do not attempt to perform maintenance or operate this machine until you have read and understand the information contained in this manual.

The drawings, illustrations, photographs, and specifications in this user manual represent your machine at time of print. However, changes may be made to your machine or this manual at any time with no obligation to Steel City Tool Works.

WARRANTY

STEEL CITY TOOL WORKS 5 YEAR LIMITED WARRANTY

Steel City Tool Works, LLC (“SCTW”) warrants all “STEEL CITY TOOL WORKS” machinery to be free of defects in workmanship and materials for a period of 5 years from the date of the original retail purchase by the original owner. SCTW will repair or replace, at its expense and at its option, any SCTW machine, machine part, or machine accessory which in normal use has proven to be defective, provided that the customer returns the product, shipping prepaid, to an authorized service center with proof of purchase and provides SCTW with a reasonable opportunity to verify the alleged defect by inspection. This warranty does not apply to defects due directly or indirectly to misuse, abuse, negligence, accidents, or lack of maintenance, or to repairs or alterations made or specifically authorized by anyone other than SCTW. Normal wear components are also excluded under this coverage. Every effort has been made to ensure that all SCTW machinery meets the highest quality and durability standards. We reserve the right to change specifications at any time due to our commitment to continuous improvement of the quality of our products.

EXCEPT AS SET FORTH ABOVE, SCTW MAKES NO EXPRESS OR IMPLIED REPRESENTATIONS OR WARRANTIES WITH RESPECT TO ITS MACHINERY, OR ITS CONDITION, MERCHANTABILITY, OR FITNESS FOR ANY PARTICULAR PURPOSE OR USE. SCTW FURNISHES THE ABOVE WARRANTIES IN LIEU OF ALL OTHER WARRANTIES, EXPRESS OR IMPLIED, INCLUDING THE WARRANTIES OF MERCHANTABILITY AND FITNESS FOR A PARTICULAR PURPOSE, WHICH ARE HEREBY SPECIFICALLY DISCLAIMED.

SCTW SHALL NOT BE LIABLE FOR ANY (A) SPECIAL, INDIRECT, INCIDENTAL, PUNITIVE OR CONSEQUENTIAL DAMAGES, INCLUDING WITHOUT LIMITATION LOSS OF PROFITS, ARISING FROM OR RELATED TO THIS WARRANTY, THE BREACH OF ANY AGREEMENT OR WARRANTY, OR THE OPERATION OR USE OF ITS MACHINERY, INCLUDING WITHOUT LIMITATION DAMAGES ARISING FROM DAMAGE TO FIXTURES, TOOLS, EQUIPMENT, PARTS OR MATERIALS, DIRECT OR INDIRECT LOSS CAUSED BY ANY OTHER PARTY, LOSS OF REVENUE OR PROFITS, FINANCING OR INTEREST CHARGES, AND CLAIMS BY ANY THIRD PERSON, WHETHER OR NOT NOTICE OF SUCH POSSIBLE DAMAGES HAS BEEN GIVEN TO SCTW; (B) DAMAGES OF ANY KIND FOR ANY DELAY BY OR FAILURE OF SCTW TO PERFORM ITS OBLIGATIONS UNDER THIS AGREEMENT; OR (C) CLAIMS MADE A SUBJECT OF A LEGAL PROCEEDING AGAINST SCTW MORE THAN ONE (1) YEAR AFTER SUCH CAUSE OF ACTION FIRST AROSE.

The validity, construction and performance of this Warranty and any sale of machinery by SCTW shall be governed by the laws of the Commonwealth of Pennsylvania, without regard to conflicts of laws provisions of any jurisdiction. Any action related in any way to any alleged or actual offer, acceptance or sale by SCTW, or any claim related to the performance of any agreement including without limitation this Warranty, shall take place in the federal or state courts in Allegheny County, Pennsylvania.

STEEL CITY TOOL WORKS

WARRANTY CARD

Name _____
 Street _____
 Apt. No. _____
 City _____ State _____ Zip _____
 Phone Number _____
 E-Mail _____

Product Description: _____
 Model No.: _____
 Serial No. _____

The following information is given on a voluntary basis and is strictly confidential.

1. Where did you purchase your STEEL CITY machine?
 Store: _____
 City: _____

2. How did you first learn of Steel City Tool Works?
 Advertisement Mail Order Catalog
 Web Site Friend
 Local Store Other _____

3. Which of the following magazines do you subscribe to?
 American Woodworker American How-To
 Cabinetmaker Family Handyman
 Fine Homebuilding Fine Woodworking
 Journal of Light Construction Old House Journal
 Popular Mechanics Popular Science
 Popular Woodworking Today's Homeowner
 WOOD Woodcraft
 WOODEN Boat Woodshop News
 Woodsmith Woodwork
 Woodworker Woodworker's Journal
 Workbench Other _____

4. Which of the following woodworking / remodeling shows do you watch?
 Backyard America The American Woodworker
 Home Time The New Yankee Workshop
 This Old House Woodwright's Shop
 Other _____

5. What is your annual household income?
 \$20,000 to \$29,999 \$30,000 to \$39,999
 \$40,000 to \$49,999 \$50,000 to \$59,999
 \$60,000 to \$69,999 70,000 to \$79,999
 \$80,000 to \$89,999 \$90,000 +

6. What is your age group?
 20 to 29 years 30 to 39 years
 40 to 49 years 50 to 59 years
 60 to 69 years 70 + years

7. How long have you been a woodworker?
 0 to 2 years 2 to 8 years
 8 to 20 years over 20 years

8. How would you rank your woodworking skills?
 Simple Intermediate
 Advance Master Craftsman

9. How many Steel City machines do you own? _____

10. What stationary woodworking tools do you own?
Check all that apply.
 Air Compressor Band Saw
 Drill Press Drum Sander
 Dust Collection Horizontal Boring Machine
 Jointer Lathe
 Mortiser Panel Saw
 Planer Power Feeder
 Radial Arm Saw Shaper
 Spindle Sander Table Saw
 Vacuum Veneer Press Wide Belt Sander
 Other _____

11. Which benchtop tools do you own? *Check all that apply.*
 Belt Sander Belt / Disc Sander
 Drill Press Band Saw
 Grinder Mini Jointer
 Mini Lathe Scroll Saw
 Spindle / Belt Sander Other _____

12. Which portable / hand held power tools do you own?
Check all that apply.
 Belt Sander Biscuit Jointer
 Dust Collector Circular Saw
 Detail Sander Drill / Driver
 Miter Saw Orbital Sander
 Palm Sander Portable Thickness Planer
 Saber Saw Reciprocating Saw
 Router Other _____

13. What machines / accessories would you like to see added to the STEEL CITY line?

14. What new accessories would you like to see added?

15. Do you think your purchase represents good value?
 Yes No

16. Would you recommend STEEL CITY products to a friend?
 Yes No

17. Comments:

CUT HERE

FOLD ON DOTTED LINE

PLACE
STAMP
HERE

Steel City Tool Works
P.O. Box 10529
Murfreesboro, TN 37129

FOLD ON DOTTED LINE

PRODUCT SPECIFICATIONS

Motor Specifications:

Type	TEFC Induction, Ball Bearing
Continuous Duty Horsepower	1-1/2 HP
Amps	15 / 7.5
Voltage	115 / 230
Phase	Single
Hertz	60
RPM	3450 (no load)

Product Dimensions:

Footprint	24" x 22"
Length	68"
Width	22"
Height	51"
Total Net Weight	397 lbs.

Product Specifications:

Table	6" x 68"
Number of Knives	3
Cutterhead Diameter	2-1/2"
Cutterhead Speed	5,000 RPM
Cuts per Minute	15,000
Knife Adjustment	Jack screws
Fence Size Overall	4" x 38"
Maximum Depth of cut	1/2"
Maximum Depth of rabbet	1/2"

Shipping Dimensions:

JOINTER

Length	69"
Width	21.7"
Height	13"
Gross Weight	284.5 lbs.

STAND

Length	28"
Width	19.2"
Height	26.4"
Gross Weight	112.5 lbs.

ACCESSORIES AND ATTACHMENTS

There are a variety of accessories available for your Steel City Product. For more information on any accessories associated with this and other machines, please contact your nearest Steel City distributor, or visit our website at: www.steelcitytoolworks.com.

DEFINITION OF TERMS

Edge Jointing: The process of making the edge of a piece of stock straight and square

Face Jointing: Similar to edge jointing except rather than the edge it is the face of the board that is being machined flat and square.

Gum, Pitch or Resin: A sticky sap based residue that comes from wood products.

Rabbet: A rectangular cut or groove along or near the edge of a piece of wood that allows another piece to fit into it to form a joint

Snipe: Gouging or depression of the board at the ends. Snipe can occur either at the beginning of the board going into the jointer or at the end of the board as it comes out of the jointer.

FEATURE IDENTIFICATION

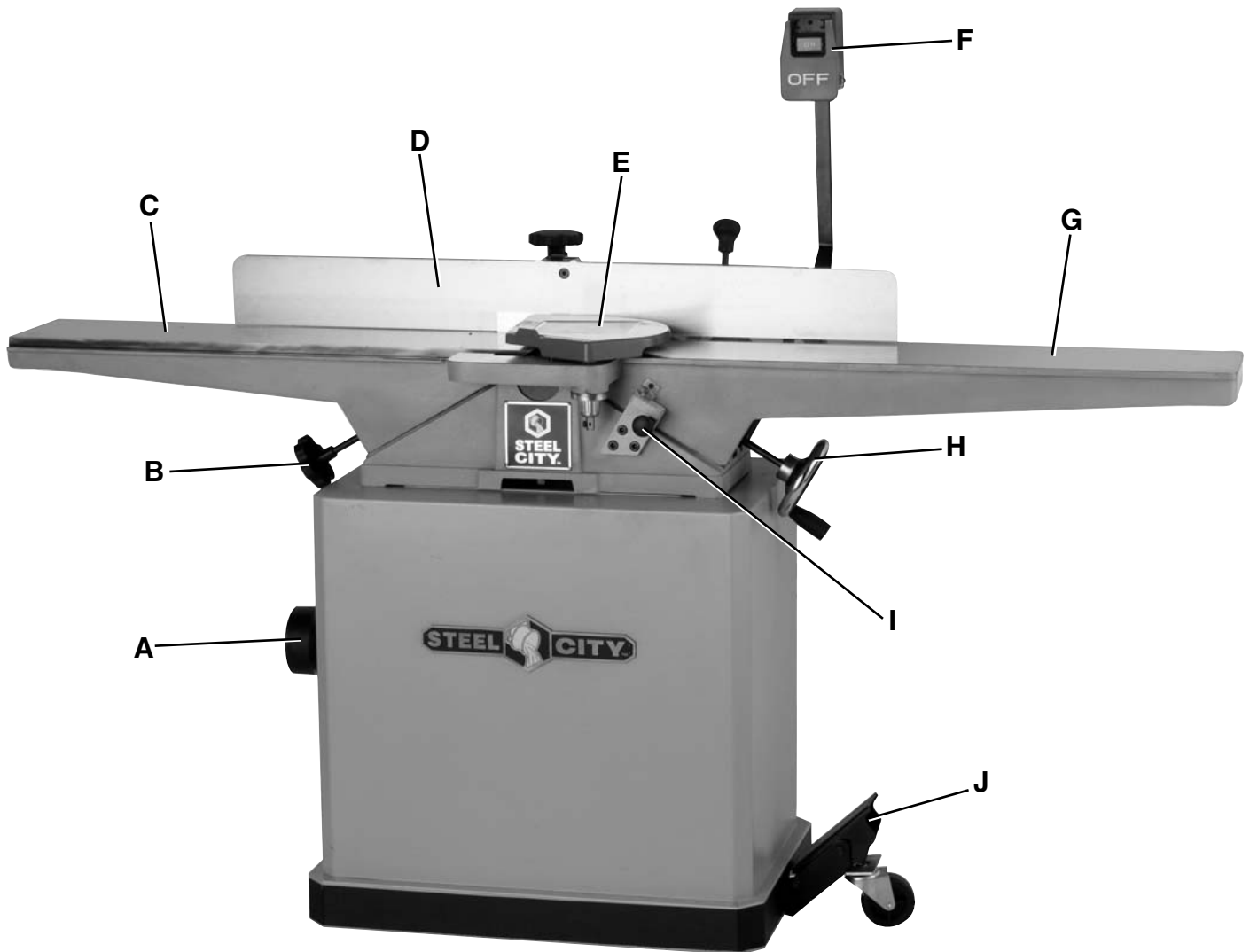

- A. DUST PORT
- B. OUTFEED TABLE ADJUSTMENT KNOB
- C. OUTFEED TABLE
- D. FENCE
- E. CUTTERHEAD GUARD
- F. POWER SWITCH
- G. INFEED TABLE
- H. INFEED TABLE ADJUSTMENT HANDWHEEL
- I. DEPTH GAUGE / STOP
- J. MOBILE BASE FOOT PEDAL

GENERAL SAFETY

⚠ WARNING

TO AVOID serious injury and damage to the machine, read and follow all Safety and Operating Instructions before assembling and operating this machine.

This manual is not totally comprehensive. It does not and can not convey every possible safety and operational problem which may arise while using this machine. The manual will cover many of the basic and specific safety procedures needed in an industrial environment.

All federal and state laws and any regulations having jurisdiction covering the safety requirements for use of this machine take precedence over the statements in this manual. Users of this machine must adhere to all such regulations.

Below is a list of symbols that are used to attract your attention to possible dangerous conditions.



This is the safety alert symbol. It is used to alert you to potential personal injury hazards. Obey all safety messages that follow this symbol to avoid possible injury or death.

⚠ DANGER

Indicates an imminently hazardous situation which, if not avoided, **WILL** result in death or serious injury.

⚠ WARNING

Indicates a potentially hazardous situation which, if not avoided, **COULD** result in death or serious injury.

⚠ CAUTION

Indicates a potentially hazardous situation, if not avoided, **MAY** result in minor or moderate injury. It may also be used to alert against unsafe practices.

CAUTION

CAUTION used without the safety alert symbol indicates a potentially hazardous situation which, if not avoided, may result in property damage.

NOTICE

This symbol is used to alert the user to useful information about proper operation of the machine.

⚠ WARNING

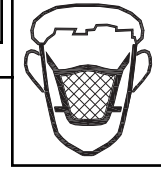

Exposure to the dust created by power sanding, sawing, grinding, drilling and other construction activities may cause serious and permanent respiratory or other injury, including silicosis (a serious lung disease), cancer, and death. Avoid breathing the dust, and avoid prolonged contact with dust. The dust may contain chemicals known to the State of California to cause cancer, birth defects or other reproductive harm.

Some examples of these chemicals are:

- Lead from lead-based paints.
- Crystalline silica from bricks, cement and other masonry products.
- Arsenic and chromium from chemically-treated lumber.

Always operate tool in well ventilated area and provide for proper dust removal. Use a dust collection system along with an air filtration system whenever possible. Always use properly fitting NIOSH/OSHA approved respiratory protection appropriate for the dust exposure, and wash exposed areas with soap and water.

1. To avoid serious injury and damage to the machine, read the entire User Manual before assembly and operation of this machine.

⚠ WARNING

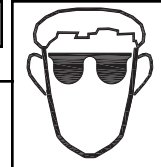

2. **ALWAYS** wear eye protection. Any machine can throw debris into the eyes during operations, which could cause severe and permanent eye damage. Everyday eyeglasses are **NOT** safety glasses. **ALWAYS** wear Safety Goggles (that comply with ANSI standard Z87.1) when operating power tools.

▲ WARNING

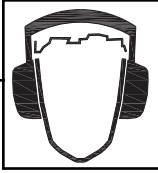

3. **ALWAYS** wear hearing protection. Plain cotton is not an acceptable protective device. Hearing equipment should comply with ANSI S3.19 Standards.

▲ WARNING

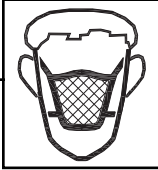

4. **ALWAYS** wear a NIOSH/OSHA approved dust mask to prevent inhaling dangerous dust or airborne particles.

5. **ALWAYS** keep the work area clean, well lit, and organized. **DO NOT** work in an area that has slippery floor surfaces from debris, grease, and wax.
6. **ALWAYS** unplug the machine from the electrical receptacle when making adjustments, changing parts or performing any maintenance.
7. **AVOID ACCIDENTAL STARTING.** Make sure that the power switch is in the "OFF" position before plugging in the power cord to the electrical receptacle.

▲ WARNING

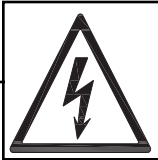

8. **AVOID** a dangerous working environment. **DO NOT** use electrical tools in a damp environment or expose them to rain or moisture.

▲ WARNING

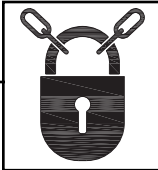

9. **CHILDPROOF THE WORKSHOP AREA** by removing switch keys, unplugging tools from the electrical receptacles, and using padlocks.

10. **DO NOT** use electrical tools in the presence of flammable liquids or gasses.

11. **DO NOT FORCE** the machine to perform an operation for which it was not designed. It will do a safer and higher quality job by only performing operations for which the machine was intended.
12. **DO NOT** stand on a machine. Serious injury could result if it tips over or you accidentally contact any moving part.
13. **DO NOT** store anything above or near the machine.
14. **DO NOT** operate any machine or tool if under the influence of drugs, alcohol, or medication.
15. **EACH AND EVERY** time, check for damaged parts prior to using any machine. Carefully check all guards to see that they operate properly, are not damaged, and perform their intended functions. Check for alignment, binding or breakage of all moving parts. Any guard or other part that is damaged should be immediately repaired or replaced.
16. Ground all machines. If any machine is supplied with a 3-prong plug, it must be plugged into a 3-contact electrical receptacle. The third prong is used to ground the tool and provide protection against accidental electric shock. **DO NOT** remove the third prong.
17. Keep visitors and children away from any machine. **DO NOT** permit people to be in the immediate work area, especially when the machine is operating.
18. **KEEP** protective guards in place and in working order.
19. **MAINTAIN** your balance. **DO NOT** extend yourself over the tool. Wear oil resistant rubber soled shoes. Keep floor clear of debris, grease, and wax.
20. **MAINTAIN** all machines with care. **ALWAYS KEEP** machine clean and in good working order. **KEEP** all blades and tool bits sharp.
21. **NEVER** leave a machine running, unattended. Turn the power switch to the OFF position. **DO NOT** leave the machine until it has come to a complete stop.
22. **REMOVE ALL MAINTENANCE TOOLS** from the immediate area prior to turning the machine ON.
23. **SECURE** all work. When it is possible, use clamps or jigs to secure the workpiece. This is safer than attempting to hold the workpiece with your hands.
24. **STAY ALERT**, watch what you are doing, and use common sense when operating any machine. **DO NOT** operate any machine tool while tired or under the influence of drugs, alcohol, or medication. A moment of inattention while operating power tools may result in serious personal injury.

25. **USE ONLY** recommended accessories. Use of incorrect or improper accessories could cause serious injury to the operator and cause damage to the machine. If in doubt, **DO NOT** use it.
26. **THE USE** of extension cords is not recommended for 230V equipment. It is better to arrange the placement of your equipment and the installed wiring to eliminate the need for an extension cord. If an extension cord is necessary, refer to the chart in the Grounding Instructions section to determine the minimum gauge for the extension cord. The extension cord must also contain a ground wire and plug pin.
27. Wear proper clothing, **DO NOT** wear loose clothing, gloves, neckties, or jewelry. These items can get caught in the machine during operations and pull the operator into the moving parts. Users must wear a protective cover on their hair, if the hair is long, to prevent it from contacting any moving parts.
28. **SAVE** these instructions and refer to them frequently and use them to instruct other users.
29. Information regarding the safe and proper operation of this tool is also available from the following sources:
 - Power Tool Institute
1300 Summer Avenue
Cleveland, OH 44115-2851
www.powertoolinstitute.org
 - National Safety Council
1121 Spring Lake Drive
Itasca, IL 60143-3201
 - American National Standards Institute
25 West 43rd Street, 4th floor
New York, NY 10036
www.ansi.org
 - ANSI 01.1 Safety Requirements for
Woodworking Machines, and the U.S. Department
of Labor regulations
www.osha.gov

PRODUCT SAFETY

1. Serious personal injury may occur if normal safety precautions are overlooked or ignored. Accidents are frequently caused by lack of familiarity or failure to pay attention. Obtain advice from supervisor, instructor, or another qualified individual who is familiar with this machine and its operations.
2. Every work area is different. Always consider safety first, as it applies to your work area. Use this machine with respect and caution. Failure to do so could result in serious personal injury and damage to the machine.
3. Prevent electrical shock. Follow all electrical and safety codes, including the National Electrical Code (NEC) and the Occupational Safety and Health Regulations (OSHA). All electrical connections and wiring should be made by qualified personnel only.

WARNING

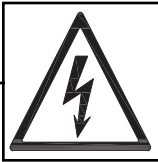

4. **TO REDUCE** the risk of electrical shock. **DO NOT** use this machine outdoors. **DO NOT** expose to rain or moisture. Store indoors in a dry area.
5. **STOP** using this machine, if at any time you experience difficulties in performing any operation. Contact your supervisor, instructor or machine service center immediately.
6. Safety decals are on this machine to warn and direct you to how to protect yourself or visitors from personal injury. These decals **MUST** be maintained so that they are legible. **REPLACE** decals that are not legible.
7. **DO NOT** leave the unit plugged into the electrical outlet. Unplug the unit from the outlet when not in use and before servicing, performing maintenance tasks, or cleaning.
8. **ALWAYS** turn the power switch "OFF" before unplugging the jointer.

WARNING

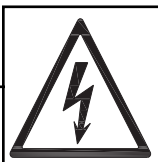

9. **DO NOT** handle the plug or jointer with wet hands.

10. **USE** accessories only recommended by Steel City.
11. **DO NOT** pull the jointer by the power cord. **NEVER** allow the power cord to come in contact with sharp edges, hot surfaces, oil or grease.
12. **DO NOT** unplug the jointer by pulling on the power cord. **ALWAYS** grasp the plug, not the cord.
13. **REPLACE** a damaged cord immediately. **DO NOT** use a damaged cord or plug. If the jointer is not operating properly, or has been damaged, left outdoors or has been in contact with water.
14. **DO NOT** use the jointer as a toy. **DO NOT** use near or around children.
15. **ENSURE** that the machine sits firmly on the floor before using. If the machine wobbles or is unstable, correct the problem by using shims or blocks prior to operation.
16. **ALWAYS** keep hands and fingers away from the blades when operating.
17. **USE** push blocks on any materials less than 3" in height or thickness.
18. **DO NOT** use the jointer on pieces less than 10" in length.
19. **NEVER** use the jointer with the depth of cut at more than 1/8".
20. **MAINTAIN** the proper relationship between the infeed and outfeed tables and the cutterhead knives.
21. **NEVER** remove any chips without turning off the machine and disconnecting the power.
22. **NEVER** turn on the machine if the workpiece is in contact with the cutterhead.
23. **ALWAYS** feed against the rotation of the cutterhead. Never apply feed pressure with your hands directly over the cutterhead. Always lift your hands, one at a time, over the cutterhead as you pass the work along the jointer bed. Always support the workpiece and maintain control throughout the operation.
24. **KEEP** cutterhead knives sharp and free of all rust and pitch.
25. **ALWAYS** disconnect the machine from the power source before making any adjustments.
26. **NEVER** perform "free hand" operations. Use the fence to position and guide the workpiece.

ELECTRICAL REQUIREMENTS

▲ WARNING



To reduce the risk of electric shock, follow all electrical and safety codes, including the National Electric Code (NEC) and the Occupational Safety and Health Regulations (OSHA). All electrical connections and wiring should be made by qualified personnel only.

The switch provided with your jointer is a dual voltage capable switch, meaning it is designed to function at either 115 or 230 volts. The switch and jointer come prewired for 115 volt operation. If you decide to convert the jointer to 230 volts, you will have to replace the 115 volt plug attached to the switch with a UL/CSA listed plug suitable for 230 volts. The jointer with a 230 volt plug should only be connected to an outlet having the same configuration as the plug. No adapter is available or should be used with the 230 volt plug. Once the modification to has been made to the plug of the switch, be sure to follow the instructions under **CHANGING MOTOR VOLTAGE** for changing the motor voltage from 115 volt to 230 volt in the **ADJUSTMENTS** section of this manual.

GROUNDING INSTRUCTIONS

⚠ WARNING



This machine **MUST BE GROUNDED** while in use to protect the operator from electric shock.

In the event of a malfunction or breakdown, **GROUNDING** provides the path of least resistance for electric current and reduces the risk of electric shock. The plug **MUST** be plugged into a matching electrical receptacle that is properly installed and grounded in accordance with **ALL** local codes and ordinances.

If a plug is provided with your machine **DO NOT** modify the plug. If it will not fit your electrical receptacle, have a qualified electrician install the proper connections to meet all electrical codes local and state. All connections must also adhere to all of OSHA mandates.

IMPROPER ELECTRICAL CONNECTION of the equipment-grounding conductor can result in risk of electric shock. The conductor with the green insulation (with or without yellow stripes) is the equipment-grounding conductor. **DO NOT** connect the equipment-grounding conductor to a live terminal if repair or replacement of the electric cord or plug is necessary.

Check with a qualified electrician or service personnel if you do not completely understand the grounding instructions, or if you are not sure the tool is properly grounded.

PLUGS/RECEPTACLES

⚠ WARNING



- Electrocutation or fire could result if this machine is not grounded properly or if the electrical configuration does not comply with local and state electrical codes.
- **MAKE CERTAIN** the machine is disconnected from power source before starting any electrical work.
- **MAKE SURE** the circuit breaker does not exceed the rating of the plug and receptacle.

The motor supplied with your machine is a 115/230 volt, 60 hertz, single phase motor. Never connect the green or ground wire to a live terminal.

The machine should only be connected to an outlet having the same configuration as the plug.

EXTENSION CORDS

⚠ WARNING

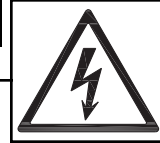

To reduce the risk of fire or electrical shock, use the proper gauge of extension cord. When using an extension cord, be sure to use one heavy enough to carry the current your machine will draw.

The smaller the gauge-number, the larger the diameter of the extension cord is. If in doubt of the proper size of an extension cord, use a shorter and thicker cord. An undersized cord will cause a drop in line voltage resulting in a loss of power and overheating.

⚠ CAUTION

USE ONLY a 3-wire extension cord that has a 3-prong grounding plug and a 3-pole receptacle that accepts the machine's plug.

If you are using an extension cord outdoors, be sure it is marked with the suffix "W-A" ("W" in Canada) to indicate that it is acceptable for outdoor use.

Make certain the extension cord is properly sized, and in good electrical condition. Always replace a worn or damaged extension cord immediately or have it repaired by a qualified person before using it.

Protect your extension cords from sharp objects, excessive heat, and damp or wet areas.

MINIMUM RECOMMENDED GAUGE FOR EXTENSION CORDS (AWG)

115 VOLT OPERATION ONLY			
	25' LONG	50' LONG	100' LONG
0 to 6 Amps	18 AWG	16 AWG	16 AWG
6 to 10 Amps	18 AWG	16 AWG	14 AWG
10 to 12 Amps	16 AWG	16 AWG	14 AWG
12 to 15 Amps	14 AWG	12 AWG	Not recommended

MINIMUM RECOMMENDED GAUGE FOR EXTENSION CORDS (AWG)

230 VOLT OPERATION ONLY			
	25' LONG	50' LONG	100' LONG
0 to 6 Amps	18 AWG	18 AWG	16 AWG
6 to 10 Amps	18 AWG	18 AWG	14 AWG
10 to 12 Amps	16 AWG	16 AWG	14 AWG
12 to 15 Amps	14 AWG	12 AWG	Not recommended

UNPACKING & INVENTORY

⚠ WARNING

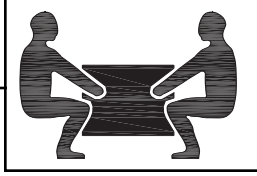

- The machine is heavy, two people are required to unpack and lift.
- Use a safety strap to avoid tip over when lifting machine.

Check shipping carton and machine for damage before unpacking. Carefully remove packaging materials, parts and machine from shipping carton. Always check for and remove protective shipping materials around motors and moving parts. Lay out all parts on a clean work surface.

Remove any protective materials and coatings from all

of the parts and the jointer. The protective coatings can be removed by spraying WD-40 on them and wiping it off with a soft cloth. This may need to be redone several times before all of the protective coatings are removed completely.

After cleaning, apply a good quality paste wax to any unpainted surfaces. Make sure to buff out the wax before assembly.

Compare the items to inventory figures; verify that all items are accounted for before discarding the shipping box.

⚠ WARNING

If any parts are missing, do not attempt to plug in the power cord and turn "ON" the machine. The machine should only be turned "ON" after all the parts have been obtained and installed correctly. For missing parts, contact Steel City at 1-877-SC4-TOOL.

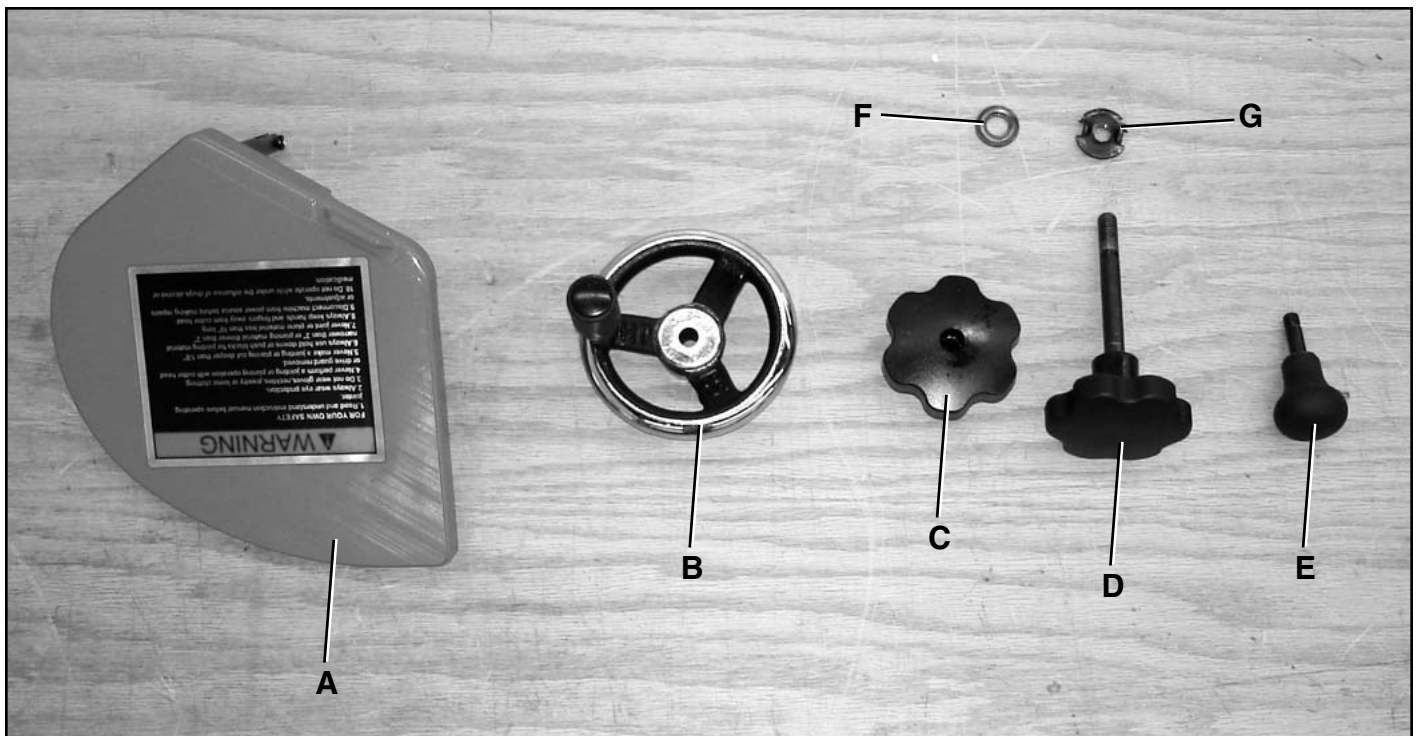

- A. CUTTERHEAD GUARD
- B. INFEED TABLE HANDWHEEL
- C. OUTFEED TABLE ADJUSTMENT KNOB
- D. FENCE LOCKING KNOB
- E. FENCE ADJUSTING KNOB
- F. KNOB WASHER
- G. SPECIAL NUT

- H. FOOT PEDAL
- I. WHEELS (2)
- J. M8 FLAT WASHER (2)
- K. M8 x 50mm HEX HEAD SCREW (2)
- L. LEVELING FEET (2)
- M. M8 HEX FLANGE NUT (2)
- N. M8 x 20mm CARRIAGE BOLT (2)

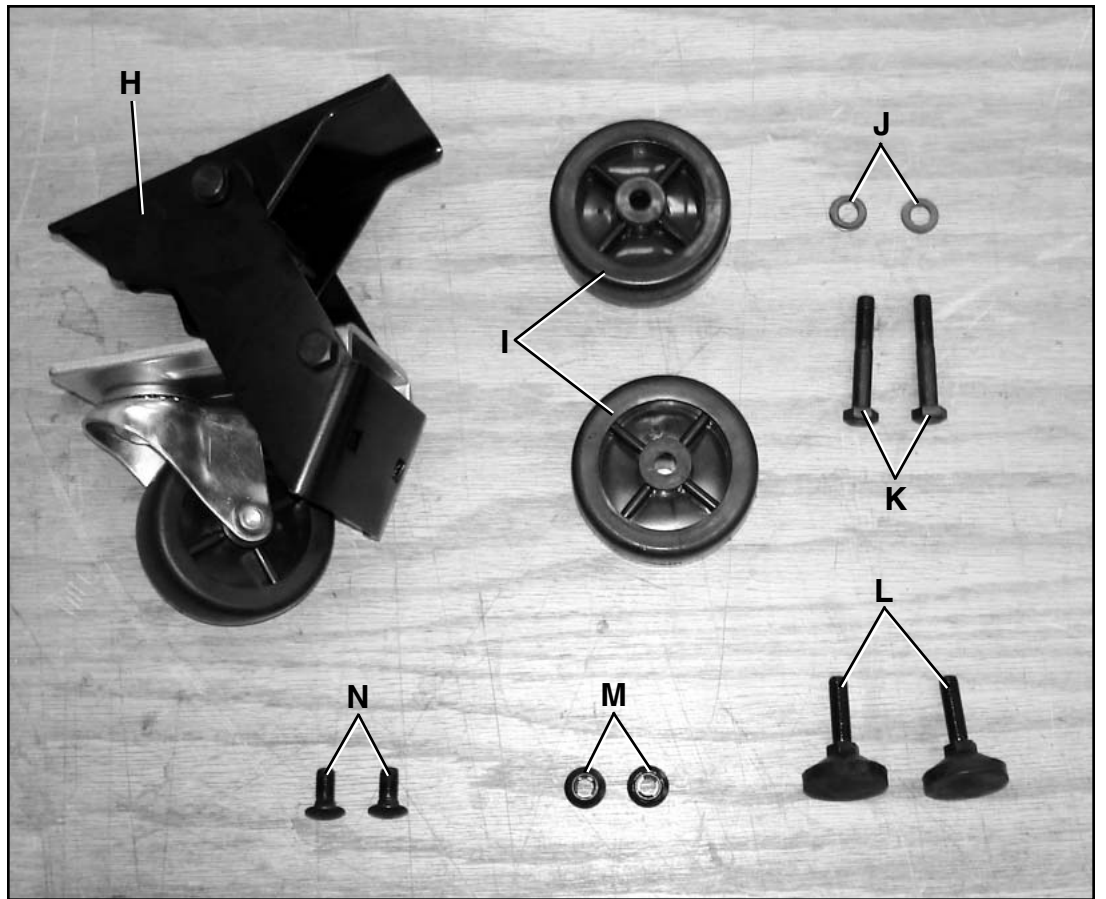

- O. CUTTERHEAD PULLEY GUARD
- P. V-BELT
- Q. DUST PORT
- R. PUSH PADDLES (2)

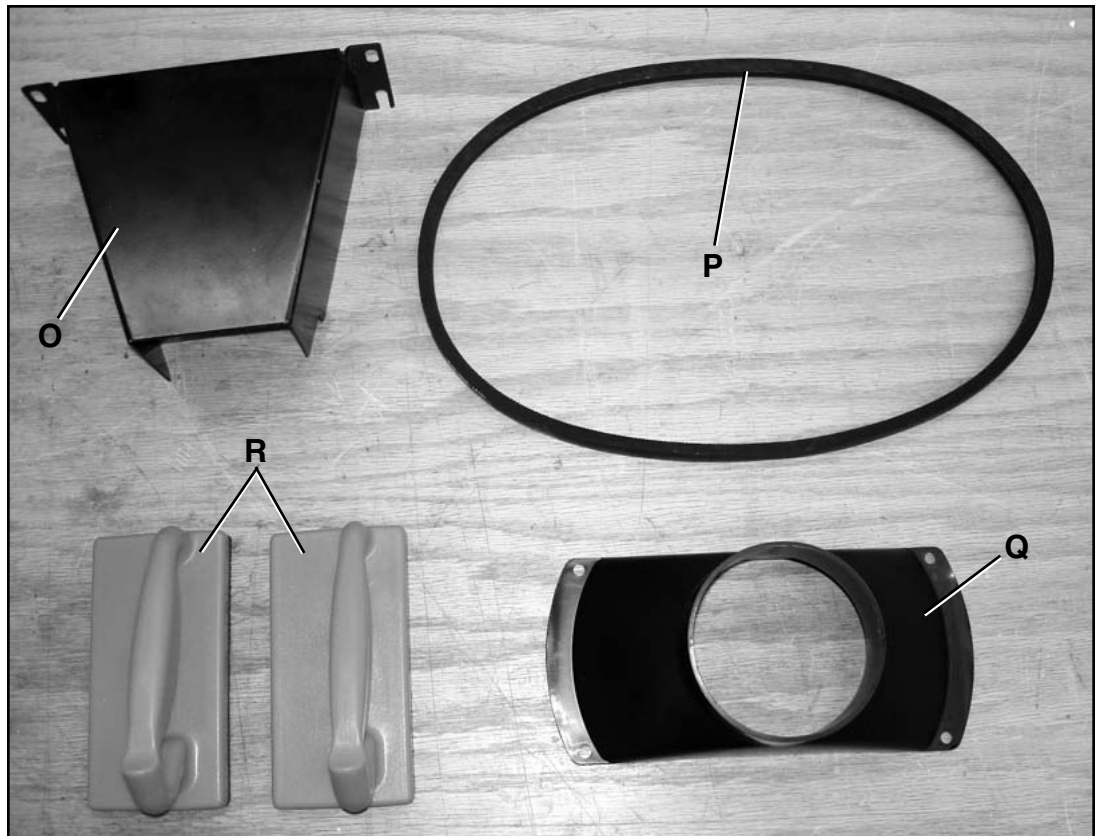

- S. POWER SWITCH
- T. HEX WRENCHES (3)
- U. OPEN END WRENCH
- V. CUTTERHEAD LOCKING TOOL

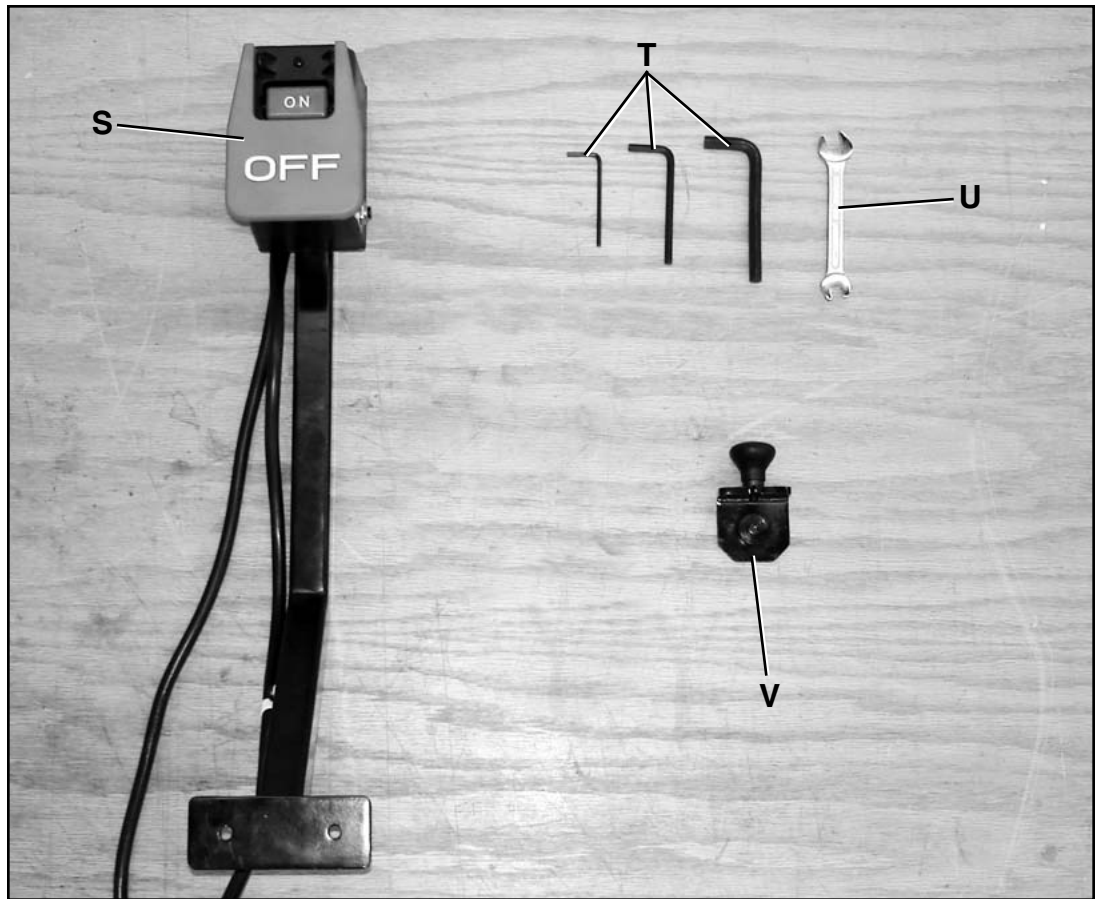

- X. M10 FLAT WASHER (3)
- Y. M10 LOCKWASHER (3)
- Z. M10 x 25mm HEX SOCKET HEAD CAP SCREW (3)
- AA. M6 x 10mm PAN HEAD SCREW
- BB. M6 x 15mm HEX SOCKET HEAD CAP SCREW (2)
- CC. M6 EXTERNAL TOOL WASHER (2)
- DD. M6 x 8mm PAN HEAD SCREW (4)
- EE. M6 x 10mm PAN HEAD FLANGE SCREW (4)

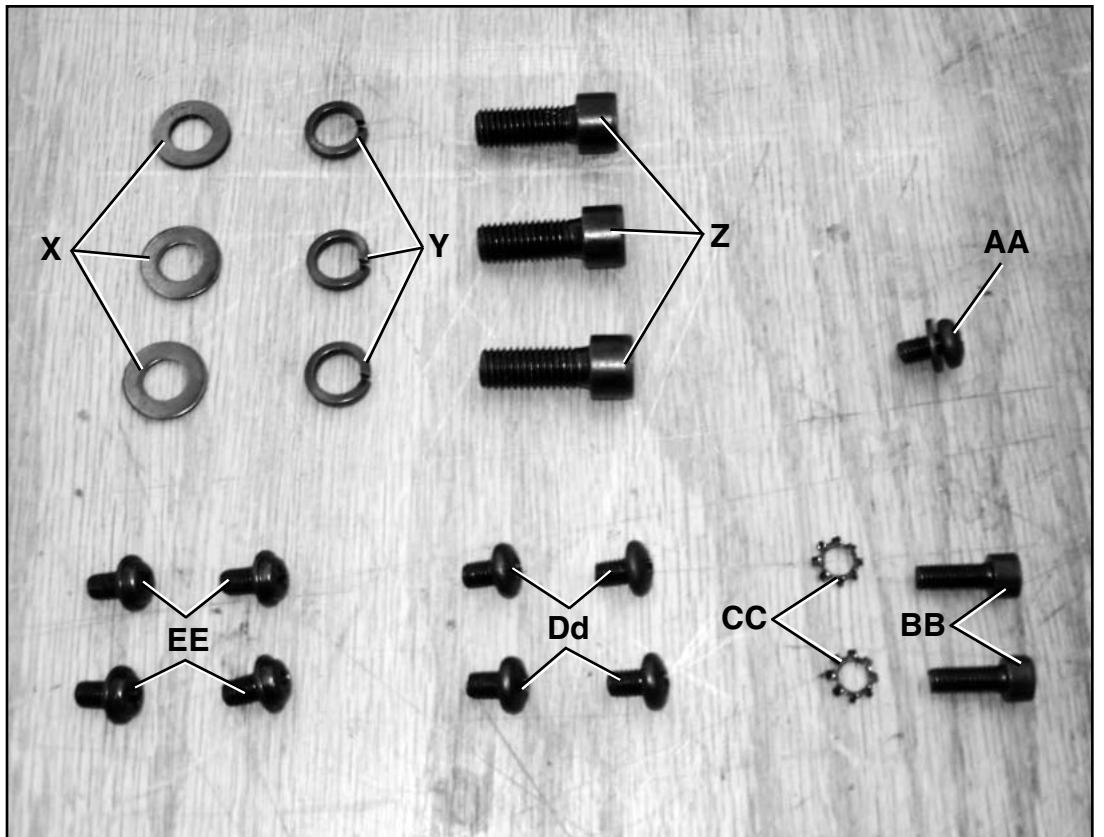

ASSEMBLY

ASSEMBLING MOBILE BASE WHEELS

1. Turn the Base (A) upside down and mount the 2 non-swiveling wheels (B) to the base using one M8 x 50mm Hex head screw and one M8 flat washer for each wheel. **SEE FIG 1.**

Fig. 1



2. Attach the leveling feet(C) to the base by screwing the threaded portion of the foot into the threaded holes in the base.
3. Attach the swiveling foot pedal (D) to the base using two M8 x 20mm Carriage bolts and two M8 hex nuts. **SEE FIG 2.**

Fig. 2

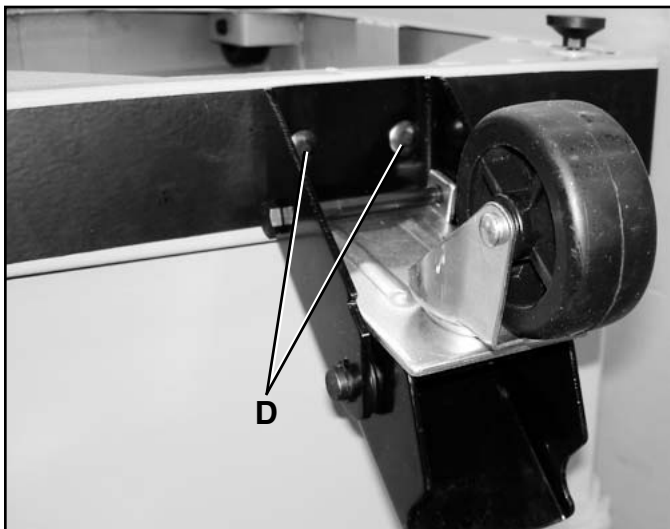

4. Turn the base back over so that the wheels are on the ground and adjust the leveling feet until the unit does not rock or wobble.

MOUNTING JOINTER TO BASE

⚠ WARNING



The Machine is heavy; two people are required to unpack and lift.

1. Remove the access panel on the rear of the jointer by removing the six M6 Phillips head screws that fasten the panel.
2. With the assistance of a helper, place the jointer on top of the base. Make certain that the cutterhead pulley on the jointer lines up with the cutout (A) in the top of the jointer base. **SEE FIG 3.**

Fig. 3



3. The jointer attaches with three M10 x 25mm socket head cap screws, three M10 lock washers and three M10 flat washers. Two are accessible through the panel in the rear of the jointer as shown at (B) in FIG 4. The third is accessed through the dust chute **SEE FIG 4, page 19.**

Fig. 4

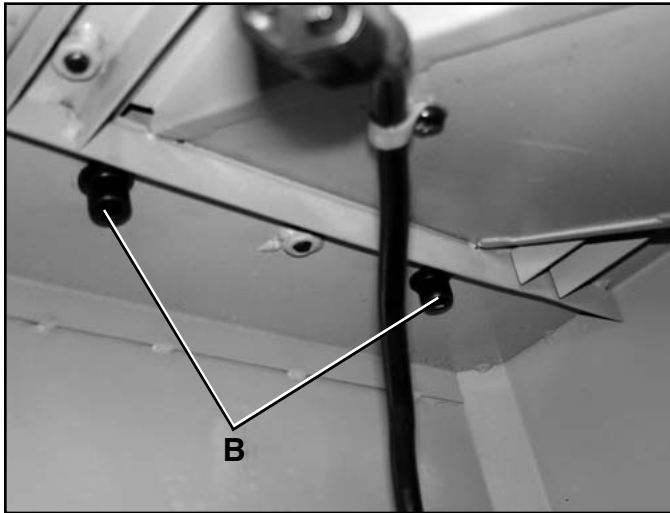

4. Tighten all three screws securely using the supplied hex wrench.

ATTACHING FENCE CARRIAGE ASSEMBLY

⚠ WARNING

MAKE CERTAIN THAT THE MACHINE IS DISCONNECTED FROM THE POWER SOURCE.

1. Place fence carriage assembly (A) on top of the jointer. Align the slot (B) in the fence carriage assembly with the slot (C) in the jointer top. SEE FIG 5.

Fig. 5

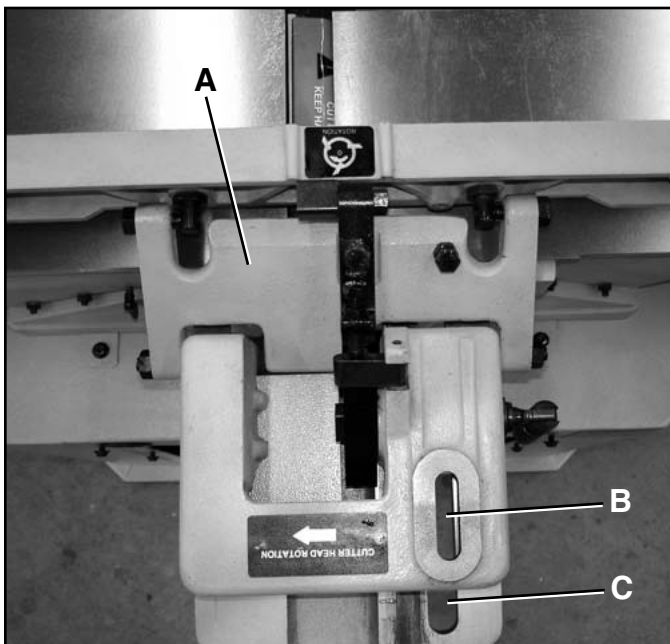
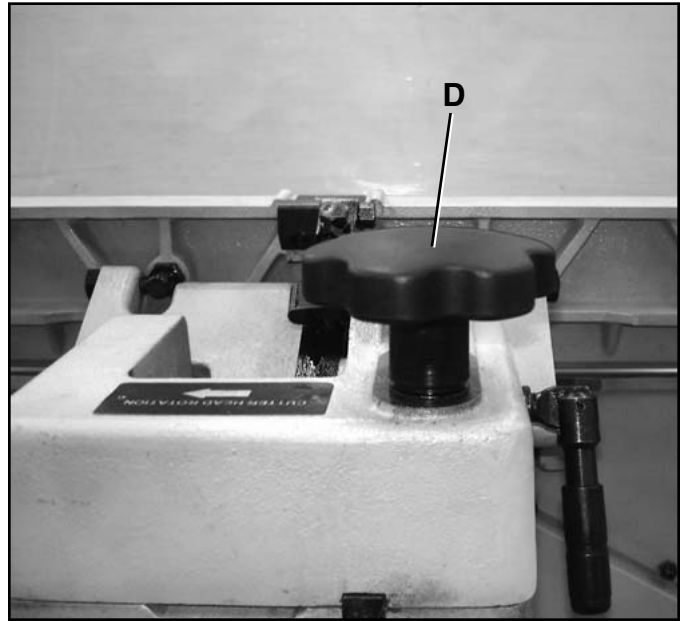

Fig. 6



2. Place knob washer on the locking knob shaft and insert locking knob (D) through the two slots and fasten using special nut (E). Make certain that the two prongs on the special nut fit into the slot on the jointer. SEE FIGS 6 and 7.

Fig. 7

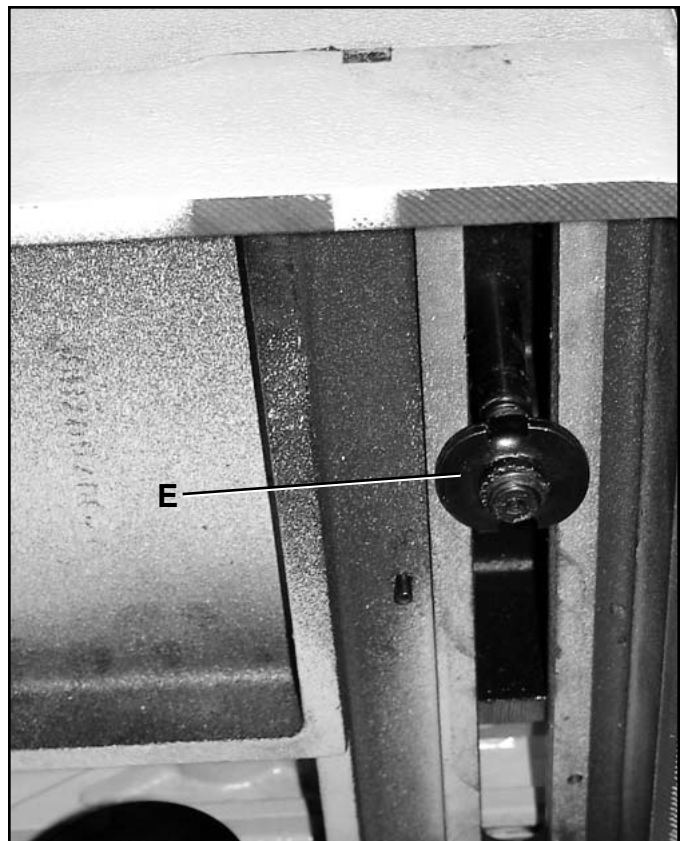
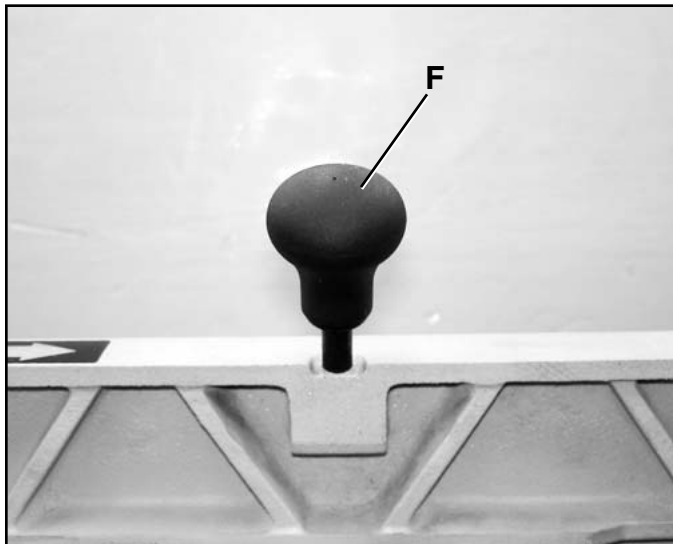

Fig. 8



3. Screw Fence Adjusting Knob (F) into the threaded hole on the top of the fence. **SEE FIG 8.**

ASSEMBLING CUTTERHEAD GUARD

⚠ WARNING

MAKE CERTAIN THAT THE MACHINE IS DISCONNECTED FROM THE POWER SOURCE.

1. Remove the screw (A) from the post (B) of the cutterhead guard (D). **SEE FIG. 9.**

Fig. 9



Fig. 9B



2. Attach the cutterhead guard to the jointer by placing the post through the hole (E) in the jointer. **SEE FIG. 9B.**
3. Turn knob (C) on the underside of the hole 1/2 turn to put tension on the return spring. This spring allows the guard to return over the cutterhead after the cut has been made.
4. Align the slot in the post with the spring, then insert post
5. Check that the guard returns completely over the cutterhead. If it does not, remove the guard and add another 1/2 turn to knob (C). Replace guard just like you did in step 4 and recheck.
6. Thread screw removed in step 1 into the cutterhead guard post. This screw keeps the guard in place.

ATTACHING INFEED TABLE ADJUSTING HANDWHEEL

⚠ WARNING

MAKE CERTAIN THAT THE MACHINE IS DISCONNECTED FROM THE POWER SOURCE.

1. Place the handwheel (A) over the shaft (C) on the infeed table side of the jointer. **SEE FIG 10.**
2. Fasten the handwheel to the shaft by tightening the set screw (B).

Fig. 10

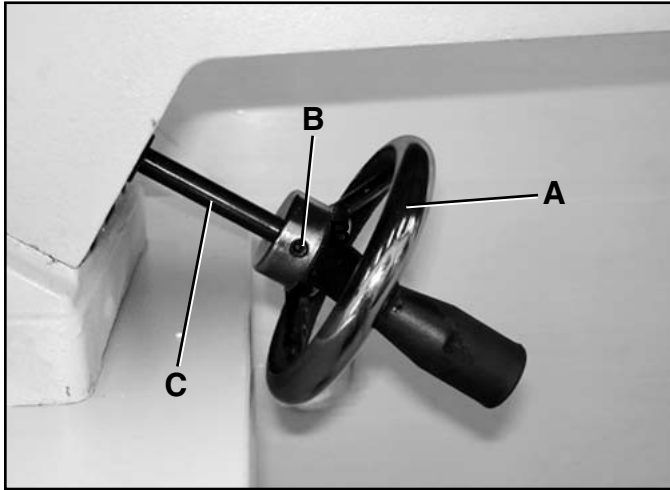

ATTACHING OUTFEED TABLE ADJUSTMENT KNOB

▲ WARNING

MAKE CERTAIN THAT THE MACHINE IS DISCONNECTED FROM THE POWER SOURCE.

Fig. 11

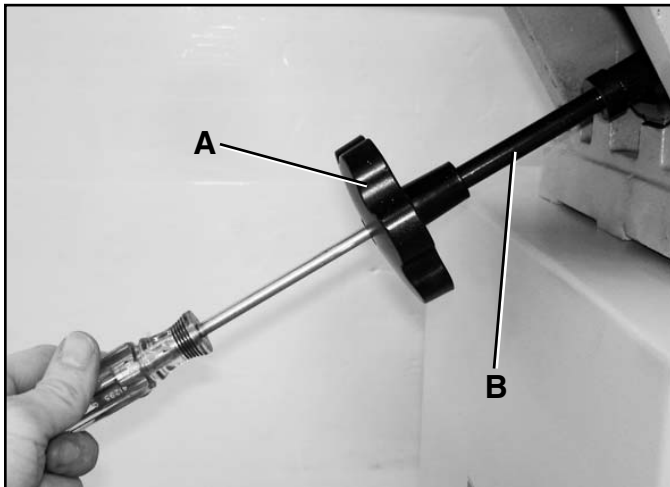

1. Attach Knob (A) to the shaft (B) on the outfeed side of the table. **SEE FIG 11.**
2. Fasten knob to the shaft using one M6 Phillips head screw. Tighten securely.

ALIGNING PULLEYS AND ASSEMBLING BELTS

▲ WARNING

MAKE CERTAIN THAT THE MACHINE IS DISCONNECTED FROM THE POWER SOURCE.

1. Place a straight edge along the face of the motor pulley and the cutterhead pulley. Make certain that they are aligned. If an adjustment is necessary, you can reposition the motor pulley on the shaft of the motor by loosening the set screw on the motor pulley and moving the motor pulley until it is aligned with the cutterhead pulley.

▲ WARNING

The outside edge of the pulley must **NEVER** be extended past the end of the motor shaft in any circumstance.

2. Place the V belt onto the cutterhead pulley (A). **SEE FIG 12.**

Fig. 12

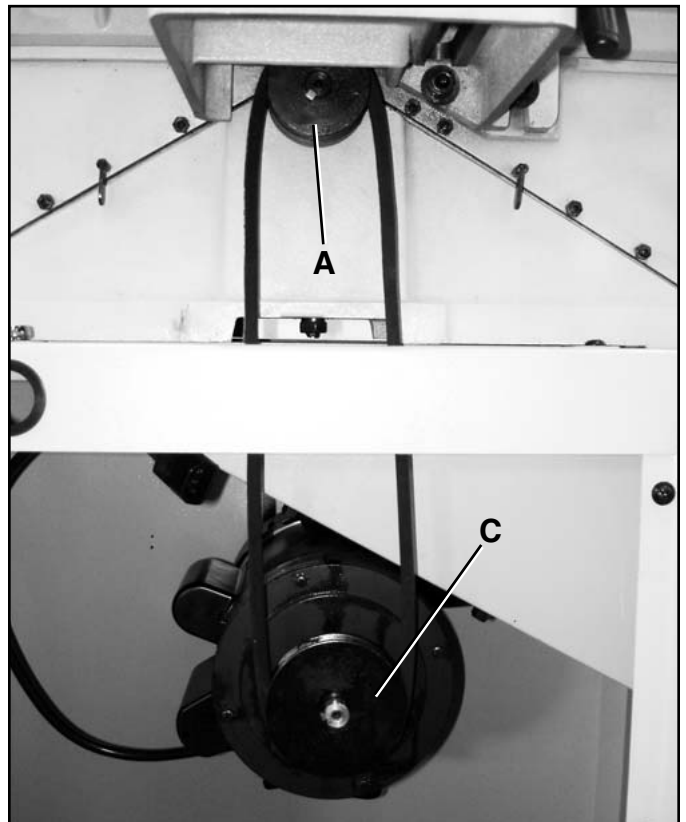

3. Position the V belt over the motor pulley (C). It may be necessary to reposition the motor in order to get the belt onto the motor pulley. If this is the case, loosen the 4 bolts (not shown) that fasten the motor to the dust chute and reposition the motor until the belt can be fitted onto the motor pulley. Retighten bolts.

NOTE: If it is necessary to move the motor, be sure to recheck pulley alignment after doing so.

4. Once the belt is positioned on both pulleys, check the belt tension by squeezing the belt at its midpoint. Proper tension is achieved when there is approximately 1" deflection at the center span of the belt using light finger pressure.
5. If an adjustment is necessary, raise or lower the motor until proper tension is achieved.

ATTACHING CUTTERHEAD PULLEY GUARD

⚠ WARNING

MAKE CERTAIN THAT THE MACHINE IS DISCONNECTED FROM THE POWER SOURCE.

The cutterhead pulley guard is attached to the jointer using four M6 x 10mm Phillips pan head flange screws (A). **SEE FIG. 13.**

Fig. 13

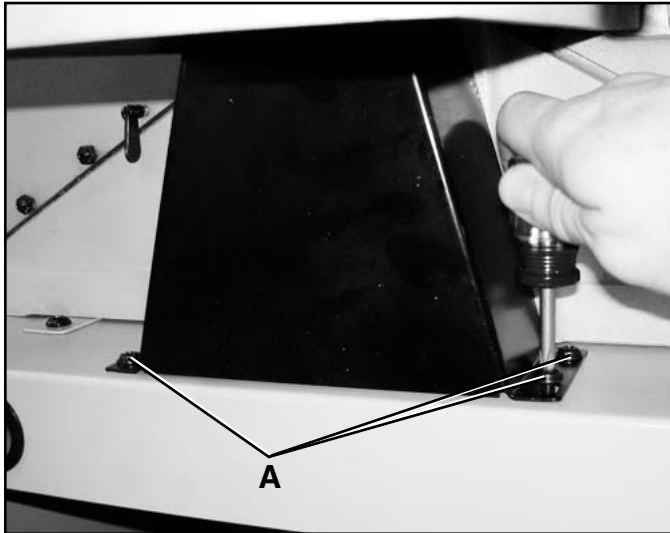

ATTACHING DUST PORT

A 4" dust port is provided for the purpose of connecting the jointer to a dust collection system. If you do not intend on connecting this unit to a dust collection system, **DO NOT** attach the dust port

The dust port is attached to the outfeed side of the jointer by using four M6 x 8mm Phillips pan head screws. **SEE FIG 14.**

Fig. 14



ATTACHING SWITCH ASSEMBLY

1. Fasten the switch assembly to the rear of the jointer using two M6 x 15mm socket head cap screws and two M6 external tooth washers. **SEE FIG 15.**

Fig. 15



2. Insert the cord through the hole (A) in the jointer stand and attach to the pigtail on the motor. **SEE FIG 16.**
3. Reattach panel on the rear of the Jointer Base.

Fig. 16

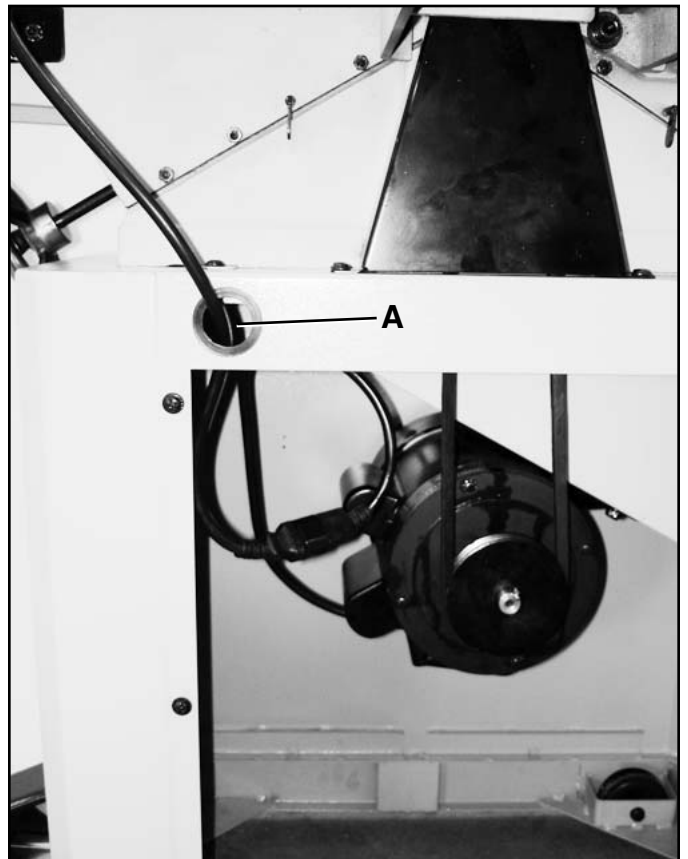

ADJUSTMENTS

INFEED TABLE ADJUSTMENT

To raise or lower the infeed table, loosen thumbscrew (C) on the rear of the jointer and rotate handwheel (A) until the table is at the desired position. **SEE FIGS. 17 and 18.**

Fig. 17

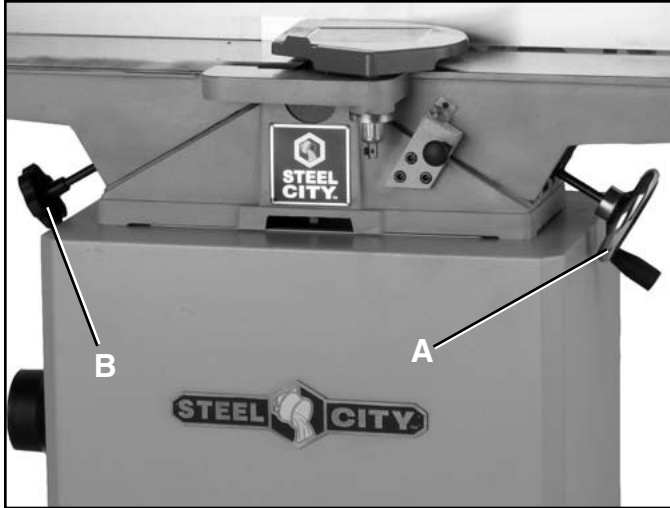
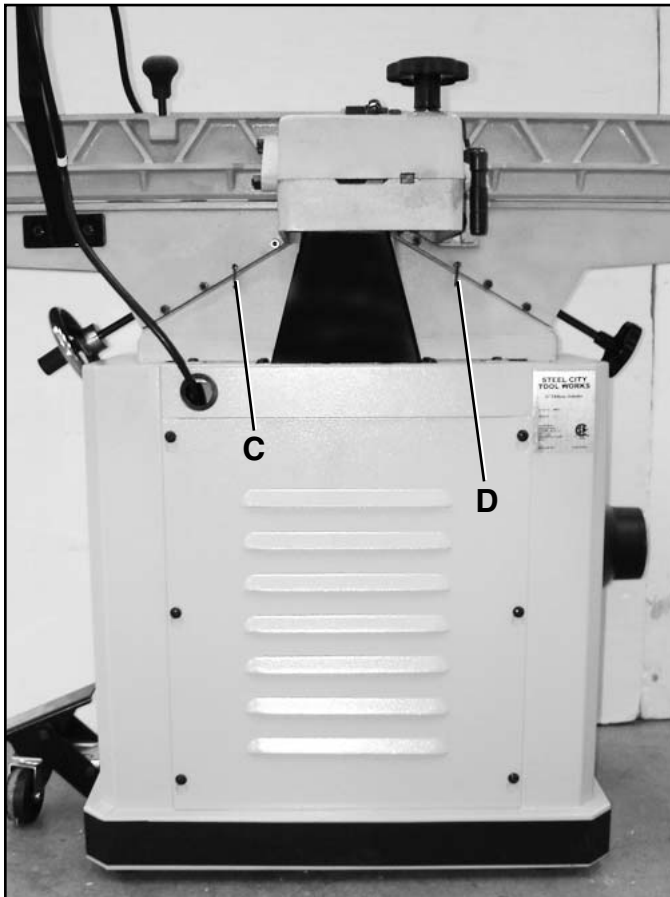

Fig. 18



INFEED POSITIVE STOP

There is a safety feature that will not allow the infeed table to drop below a 1/8-in depth of cut. Once the jointer hits a depth of 1/8", the spring loaded knob (A) snaps into a hole in the infeed table. To make the infeed table go lower than this, you will have to pull out on the knob as you lower the table. **SEE FIG 19.**

Fig. 19

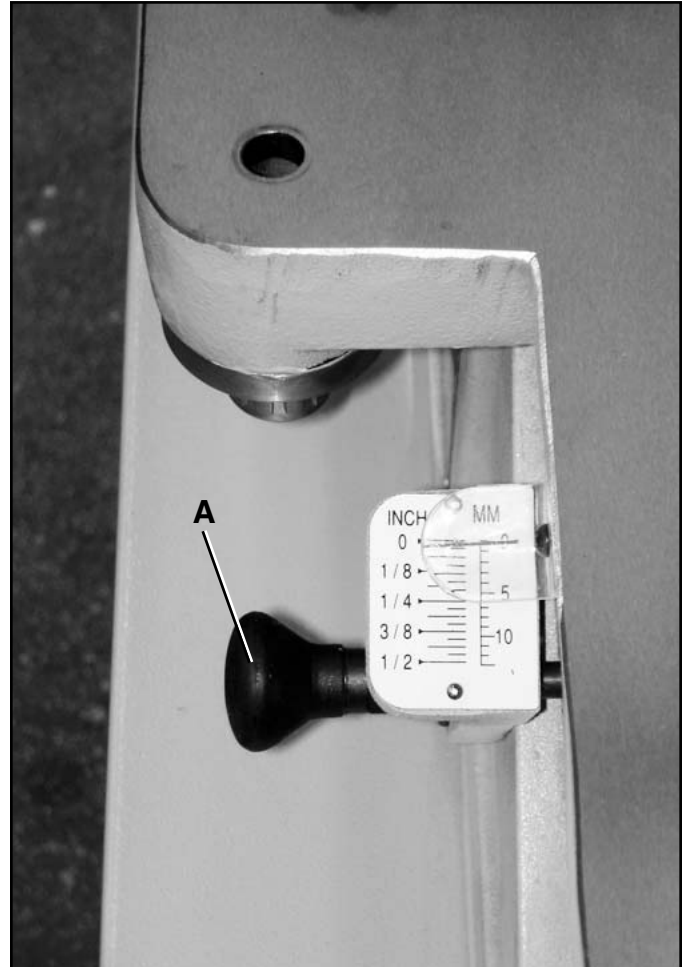

OUTFEED TABLE ADJUSTMENTS

The outfeed table must be **EXACTLY** level with the knives when the knives are at their highest point of revolution. To move the outfeed table, loosen the thumbscrew (D) and rotate the table raising and lowering knob (B) until the table is level with the knives. When the table is exactly level with the knives at their highest point of revolution, tighten thumbscrew (D). **SEE FIGS. 17 and 18.**

KNIFE ADJUSTMENTS

In order to do accurate work, the knives must be exactly level with the outfeed table. To check and adjust, proceed as follows:

⚠ WARNING

MAKE CERTAIN THAT THE MACHINE IS DISCONNECTED FROM THE POWER SOURCE.

1. Lower the infeed table far enough so that it sits lower than the outfeed table.
2. Remove the cutterhead guard.
3. Place a straight edge on the outfeed table, extending over the cutterhead as shown. **SEE FIG 20.**

Fig. 20

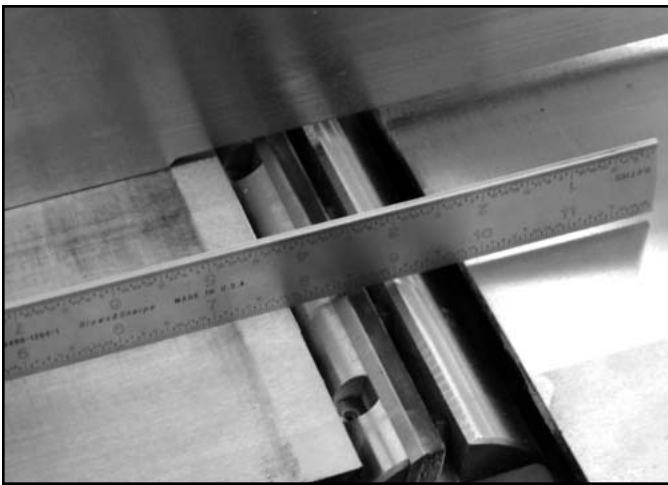

4. Carefully rotate the cutterhead by hand. The knives should just touch the straight edge.
5. If the knife is high or low at either end, slightly turn the four screws (A), in the knife locking bar counterclockwise to loosen, using an open end wrench (B). Then, using an allen wrench, adjust the height of the knife by turning the knife raising screws (C) counterclockwise to lower and clockwise to raise the knife. **SEE FIG. 21.**

⚠ WARNING

CARE MUST BE TAKEN WHEN HANDLING THE KNIVES, AS THE CUTTING EDGES ARE VERY SHARP. WEAR PROTECTIVE GLOVES WHEN HANDLING THE KNIVES.

If the knife is to be lowered, it will be necessary to carefully push down on the knife with a scrap piece of wood, after screws (C) have been turned counterclockwise to achieve desired depth. Tighten four screws (A) by turning them counterclockwise, after adjustment is made.

6. Repeat these procedures for adjusting the remaining two knives if necessary, and replace cutterhead guard removed in STEP 2.

Fig. 21

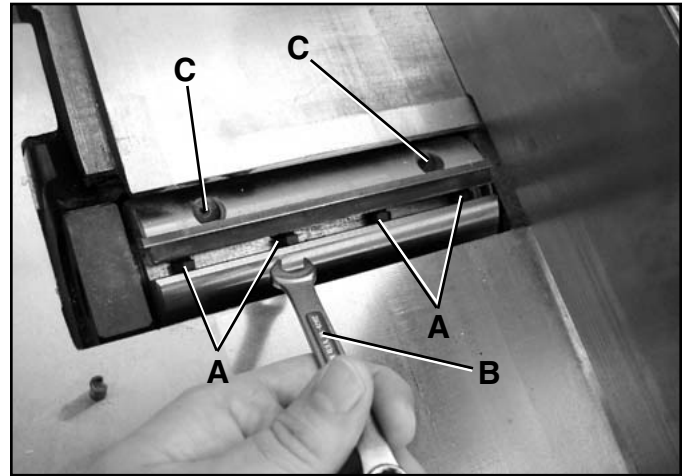

7. If the knives are set too low, the finished surface will be curved. If the knives are set too high, the work will be gouged, curved, or bowed at the end of the cut.
8. As a final check, run a piece of work slowly over the knives for 6 to 8 inches. The wood should rest firmly on both tables with no open spaces under the finished cut.

ADJUSTING FENCE POSITIVE STOPS

The fence on your jointer is equipped with positive stops at the most used fence positions of 90 degrees and 45 degrees in and out. To check and adjust the positive stops, proceed as follows:

⚠ WARNING

MAKE CERTAIN THAT THE MACHINE IS DISCONNECTED FROM THE POWER SOURCE.

1. Position the fence at 90 degrees to the table by loosening the bevel lock handle (D) and moving the fence until the 90 degree stop screw (A) hits the stop (E). **SEE FIG 22.**

Fig. 22

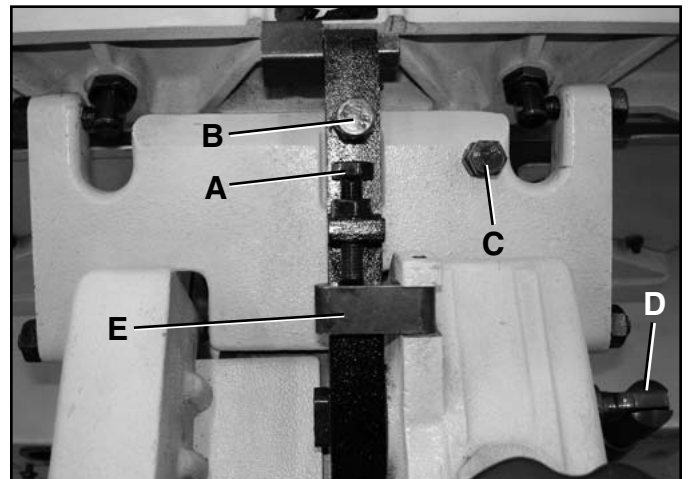

2. Using a square, check to see if the fence is at 90 degrees to the table.
3. If the fence is not at 90 degrees, loosen the hex nut located on the stop screw (A) and adjust stop screw until the fence is at 90 degrees to the table. Once this is achieved, retighten the hex nut.
4. Tilt the fence inward until the fence contacts the 45 degree stop screw (B).
5. Using a combination square, check to make sure that the fence is tilted in at 45 degrees. **SEE FIG 23.**

Fig. 23



6. If an adjustment is necessary loosen the hex nut located on the 45 degree stop screw(B) and adjust the stop screw until the fence is at 45 degrees.
7. Tilt the fence outward until it contacts the 45 degree stop (C). To do this, you will have to flip the 90 degree stop (E) out of the way. **SEE FIG 22.**
8. Using a combination square, check to make sure that the fence is tilted at 45 degrees. **SEE FIG 24.**

Fig. 24

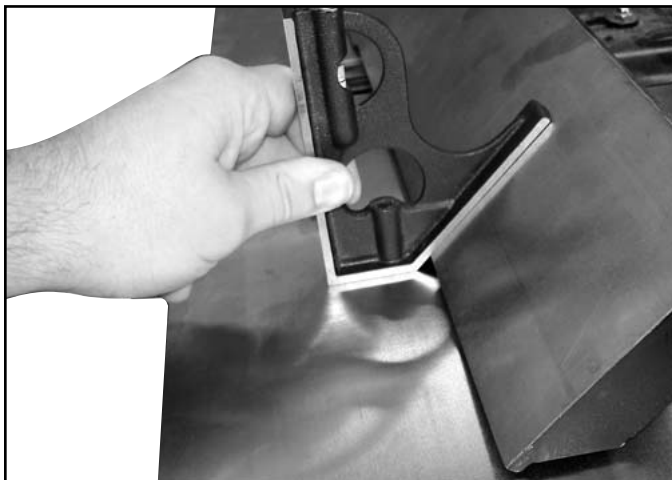

9. If an adjustment is necessary, loosen the hex nut located on the 45 degree stop (C) and adjust the stop screw until the fence is at 45 degrees to the table. **SEE FIG 22.**

CHANGING MOTOR VOLTAGE

⚠ WARNING

MAKE CERTAIN THAT THE JOINTER IS DISCONNECTED FROM THE POWER SOURCE. Have a certified electrician make all electrical connections. All local and state codes must be maintained.

The motor supplied with the jointer is a dual voltage 115/230-volt, single phase motor. The motor is wired from the factory for 115-volt operation. To change to 230-volt operation for your jointer, proceed with the following instructions. It is also necessary to replace the 115 volt plug, supplied with the jointer, with a UL/CSA Listed plug (not included) suitable for 230 volts and the rated current of the motor. The jointer with a 230 volt plug should only be connected to an outlet having the same configuration as the plug. No adapter is available or should be used with the 230 volt plug.

1. Make sure the switch is "OFF" and disconnect power cord from power source.
2. Unscrew the six screws that fasten the access panel to the base of the jointer and remove access panel.
3. If motor tag states that it is dual voltage remove junction box cover (A) on motor. **SEE FIG. 24A.**

Fig. 24A



4. Using wiring diagram on inside of junction box cover, reconnect motor leads for 230-volt operation.
5. Replace junction box cover and reattach panel removed on step 2.
6. Replace the 115-volt plug with a plug rated for 230-volt operation.
7. The ON/OFF switch is 4-pole and does not need modified.

OPERATIONS

According to many OSHA, ANSI, STATE, and LOCAL CODES, it is the Employers Responsibility to:

- **PERMIT ONLY** trained and authorized employees to operate equipment.
- **INSPECT AND MAINTAIN** guards, safety devices and start/stop controls.
- **INSTRUCT, TRAIN** and **SUPERVISE** the safe method of work.

⚠ WARNING

Serious personal injury may occur if normal safety precautions are overlooked or ignored. Accidents are frequently caused by lack of familiarity or failure to pay attention. Obtain advice from supervisor, instructor, or another qualified individual who is familiar with the machine and its operations.

Every work area is different. Always consider safety first, as it applies to your work area. Use any machine with respect and caution. Failure to do so could result in serious personal injury and damage to the machine.

STOP using the machine, if at any time you experience difficulties in performing any operation. Contact your supervisor, instructor or machine service center immediately.

START/STOP SWITCH

The START/STOP switch assembly is located above the infeed table. To turn the jointer "ON", push the green start button (A). To turn the jointer "OFF", push the red stop paddle (B). **SEE FIG. 23.**

Fig. 23

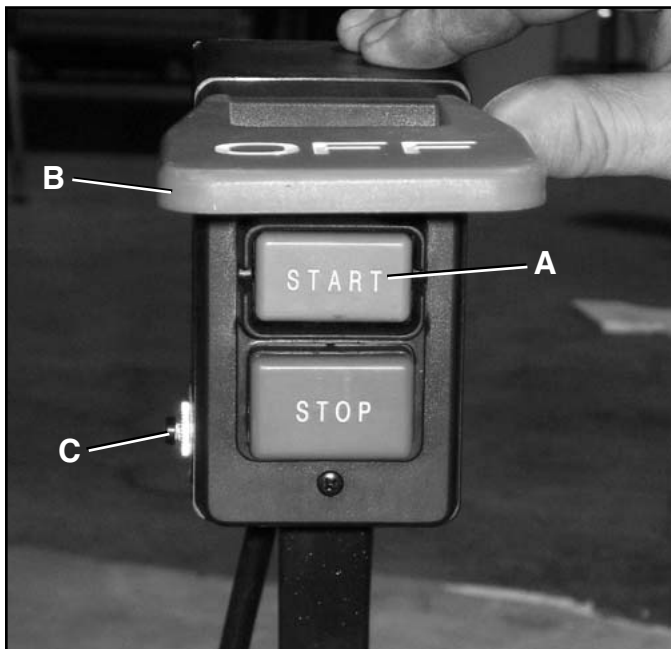

⚠ WARNING

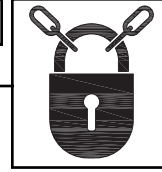

CHILDPROOF THE WORKSHOP AREA by removing switch keys, unplugging tools from the electrical receptacles, and using padlocks.

LOCKING SWITCH IN THE "OFF" POSITION

When the jointer is not in use, the start button can be locked so that it cannot be started, using a padlock through the holes in the side of the start button.

CIRCUIT BREAKER

Your jointer is supplied with a resettable circuit breaker (C). It is located on the side of the start/stop switch box. If the motor shuts off or fails to start due to an overload condition, turn the jointer "OFF", let the motor cool for three to five minutes, and push the reset button on the circuit breaker to reset the breaker. The motor can then be turned on again in the usual manner. **SEE FIG. 25.**

The following directions will give the beginner a start on jointer operations. Use scrap pieces of lumber to check settings and to get the feel of the operations before attempting regular work.

CAUTION

THE KNIVES ON THE JOINTER WILL NOT WEAR EVENLY BY FEEDING THE WOOD THROUGH THE SAME SPOT ON THE TABLE EVERY TIME. FEED THE WOOD THROUGH THE JOINTER AT DIFFERENT SPOTS ON THE TABLE BY REPOSITIONING THE FENCE WHEN POSSIBLE, TO HELP ELIMINATE UNEVEN WEAR OF THE KNIVES.

⚠ WARNING

ALWAYS USE CUTTERHEAD GUARD AND KEEP HANDS AWAY FROM CUTTERHEAD. ALWAYS USE PUSH BLOCKS WHENEVER POSSIBLE. NEVER MAKE JOINTING AND PLANING CUTS DEEPER THAN 1/8" IN ONE PASS.

PLACEMENT OF HANDS DURING FEEDING

At the start of the cut, the left hand holds the work firmly against the infeed table and fence, while the right hand pushes the work toward the knives. After the cut is underway, the new surface rests firmly on the outfeed table. The left hand should then be moved to the work on the outfeed table, at the same time maintaining flat contact with the fence. The right hand presses the work forward, and before the right hand reaches the cutterhead, it should be moved to the work on the outfeed table.

⚠ WARNING

NEVER PASS HANDS DIRECTLY OVER THE CUTTERHEAD.

DIRECTION OF GRAIN

Avoid feeding work into the jointer against the grain. The result will be chipped and splintered edges. Feed with the grain to obtain a smooth surface.

FENCE OPERATION

The fence can be moved across the table by loosening the lock knob (A), moving the fence to the desired position and retightening the lock knob securely. As the fence is moved across the table, the sliding portion of the fence bracket (B) guards the cutterhead in back of the fence. **SEE FIG. 24.**

Fig. 24

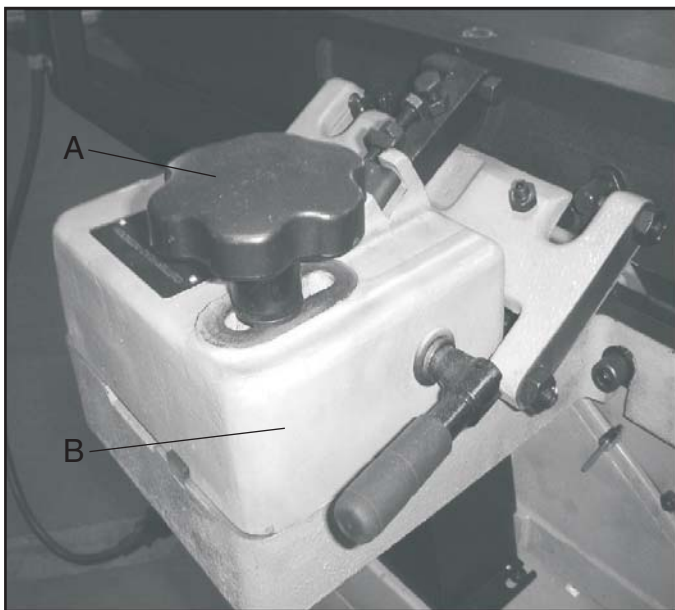

JOINTING AN EDGE

This is the most common operation for the jointer. These cuts are made to square an edge of a workpiece. Set the guide fence square with the table. Depth of cut should be the minimum required to obtain a straight edge. Hold the best face of the piece firmly against the fence throughout the feed as shown in Fig. 25. **SEE FIG 25**

Fig. 25



CAUTION

MAXIMUM DEPTH OF CUT SHOULD NOT BE MORE THAN 1/8" IN ONE PASS.

⚠ CAUTION

DO NOT PERFORM JOINTING OPERATIONS ON MATERIAL SHORTER THAN 10 INCHES, NARROWER THAN 3/4 INCH. OR LESS THAN 1/2 INCH THICK.

□

SURFACING

Surfacing is identical to the jointing operation except for the position of the workpiece. For surfacing, the major flat surface of the workpiece is placed on the infeed table of the jointer with the narrow edge of the workpiece against the fence, as shown in Fig. 28. The workpiece is moved from the infeed table, across the cutterhead to the outfeed table, establishing a flat surface on the workpiece. **SEE FIG. 28.**

Fig. 28



⚠ WARNING

ALWAYS USE PUSH BLOCKS WHEN PERFORMING SURFACING OPERATIONS AND NEVER PASS YOUR HANDS DIRECTLY OVER THE CUTTERHEAD.

CAUTION

MAXIMUM DEPTH OF CUT SHOULD NOT BE MORE THAN 1/8" IN ONE PASS.

BEVELING

To cut a bevel, lock the fence at the required angle and run the work across the knives while keeping the work firmly against the fence and tables. Several passes may be necessary to arrive at the desired result. When the angle is small, there is little difference whether the fence is tilted in or out. However, at greater angles approaching 45 degrees, it is increasingly difficult to hold the work properly when the fence is tilted out. The advantage of the double-tilting fence is appreciated under such conditions. When tilted in, the fence forms a V-shape with the tables, and the work is easily pressed into the pocket while passing it across the knives. If the bevel is laid out on the piece in such direction that this involves cutting against the grain, it will be better to tilt the fence out.

TAPER CUTS

One of the most useful jointer operations is cutting an edge to a taper. This method can be used on a wide variety of work. Tapered legs of furniture are a common example. Instead of laying the piece on the infeed table, lower the forward end of the work onto the outfeed table. Do this very carefully, as the piece will span the knives, and they will take a "bite" from the work with a tendency to kick back unless the piece is firmly held. Now push the work forward as in ordinary jointing. The effect is to surface off all the stock in front of the knives, to increasing depth, leaving a tapered surface. The ridge left by the knives when starting the taper may be removed by taking a very light cut according to the regular method for jointing, with the infeed table raised to its usual position. Practice is required in this operation, and the beginner is advised to make trial cuts on waste material. Taper cuts over part of the length and a number of other special operations can easily be done by the experienced craftsman.

CUTTING A RABBET

When making a rabbet cut, the cutterhead guard must be removed.

⚠ CAUTION

AFTER THE RABBET CUT IS COMPLETED, BE CERTAIN GUARD IS REPLACED.

1. Adjust the fence so that the distance between the end of the knives and the fence is equal to the width of the rabbet.
2. Lower the infeed table an amount equal to the depth of the rabbet. If the rabbet is quite deep, it may be necessary to cut it in two or more passes. In that event, the table is lowered an amount equal to about half the depth of the rabbet for the first pass, then lowered again to proper depth to complete the cut.

SURFACING WARPED PIECES

If the wood to be surfaced is dished or warped, take light cuts until the surface is flat. Avoid forcing such material down against the table; excessive pressure will spring it while passing the knives, and it will spring back and remain curved after the cut is completed.

SURFACING SHORT OR THIN WORK

⚠ CAUTION

WHEN SURFACING SHORT OR THIN PIECES, ALWAYS USE PUSH BLOCKS TO MINIMIZE ALL DANGER TO THE HANDS.

Fig. 28 illustrates using the push blocks properly. **SEE FIG. 28.**

⚠ CAUTION

DO NOT PERFORM SURFACING OPERATIONS ON MATERIAL SHORTER THAN 10 INCHES, NARROWER THAN 3/4 INCH, WIDER THAN 6 INCHES, OR LESS THAN 1/2 INCH THICK.

MAINTENANCE

- **DO NOT** begin cleaning up until you have read and understand all of the clean up instructions.
- **DO NOT USE FLAMMABLE MATERIALS TO CLEAN JOINTER.**

CLEANING

▲ WARNING

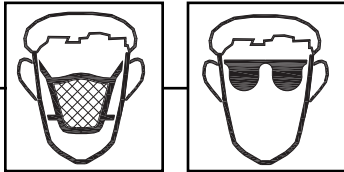

With the machine unplugged, blow off motor with low pressure air to remove dust or dirt. Air pressure above 50 P.S.I. should not be used as high-pressured air may damage insulation. The operator should always wear a respirator and eye protection when using compressed air.

Do not allow chips and dust to accumulate under jointer. Keep area clean and in safe order.

▲ WARNING

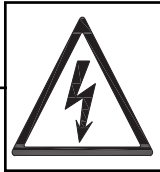

Turn the power switch "OFF" and unplug the power cord from its power source prior to any maintenance.

LUBRICATION

The jointer has sealed lubricated bearings in the motor housing that do not require any additional lubrication from the operator.

▲ WARNING

Repairs to the jointer should be performed by trained personnel only. Contact your nearest Steel City Dealer for authorized service. Unauthorized repairs or replacement with non-factory parts could cause serious injury to the operator and damage to the jointer.

After considerable use, the knives will become dull and it will not be possible to do accurate work. Unless badly damaged by running into metal or other hard material, the knives may be sharpened as follows:

WHETTING KNIVES

▲ WARNING

DISCONNECT MACHINE FROM POWER SOURCE.

Use a fine carborundum stone; cover it partly with paper to avoid marking the table. Lay the stone on the infeed table, lower the table and turn the cutterhead forward until the stone lies flat on the bevel of the knife. Hold the cutterhead from turning, and whet the beveled edge of the knife, stroking lengthwise by sliding the stone back and forth across the table. Do the same amount of whetting on each of the three knives.

REMOVING, REPLACING, AND RESETTING KNIVES

If the knives are removed from the cutterhead for replacement or sharpening, care must be used in removing, replacing, and resetting them.

▲ WARNING

DISCONNECT MACHINE FROM POWER SOURCE.

1. Move the fence to the rear and remove the cutterhead guard.
2. Insert cutterhead locking tool into the hole just to the right of the cutterhead to lock the cutterhead in place. **SEE FIG. 28A.**

Fig. 28A

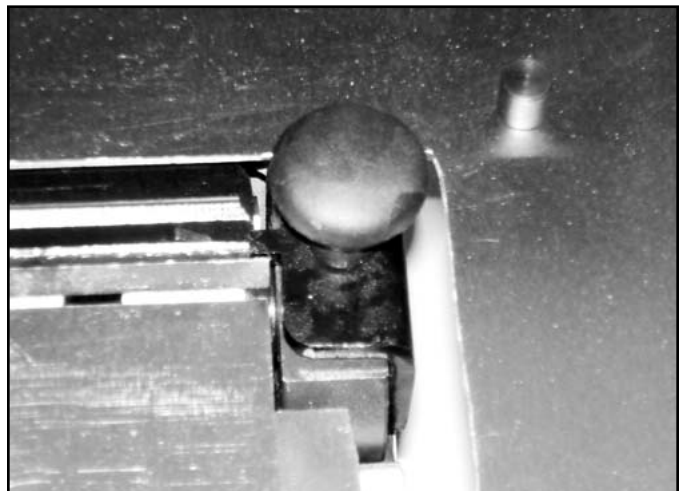

▲ WARNING

BE EXTREMELY CAREFUL THAT YOUR HANDS DO NOT COME IN CONTACT WITH THE KNIVES. THE KNIVES ARE VERY SHARP. WEAR PROTECTIVE GLOVES WHEN HANDLING THE KNIVES.

Fig. 29

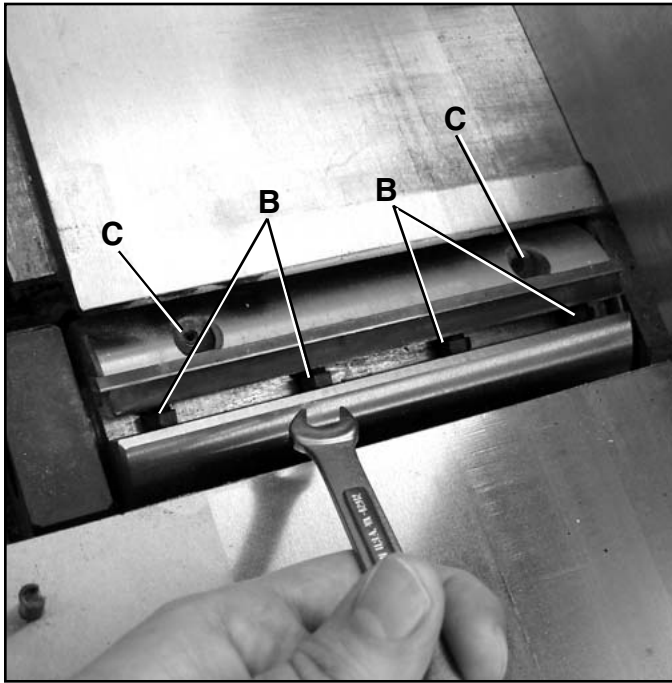

- Using wrench (A) Fig. 29, slightly loosen the four locking screws (B) in each knife slot by turning the screws (B) counterclockwise. Loosen screws (B) further and remove knife and knife locking bar. **SEE FIG. 29.**
- Using an allen wrench, lower the two knife adjustment blocks to the bottom of the cutterhead by turning screws (C) clockwise in all three slots of the cutterhead.
- Before assembling knives, make certain the knives and locking bars are thoroughly clean and free of gum and pitch.
- Place the knife locking bars and knives into each slot in the cutterhead.

⚠ WARNING

CARE MUST BE TAKEN WHEN INSERTING THE KNIVES, AS THE CUTTING EDGES ARE VERY SHARP. WEAR PROTECTIVE GLOVES WHEN HANDLING THE KNIVES.

- Push the knife down as far as possible and turn each screw (B) counterclockwise just enough to hold the knife in position. Replace the remaining two knives in the same manner.
- The knives are adjusted correctly when the cutting edge of the knife extends out .015" from the cutterhead diameter.

- Place a .015" feeler gage on the cutterhead and using a straight edge on the rear table, adjust the height of the rear table until it is .015" above the cuttinghead diameter.
- Lock the rear table in position and remove the feeler gage.
- Lower the infeed table and place a straight edge (E) on the outfeed table extending over the cutterhead (D) as shown. **SEE FIG. 30.**

Fig. 30

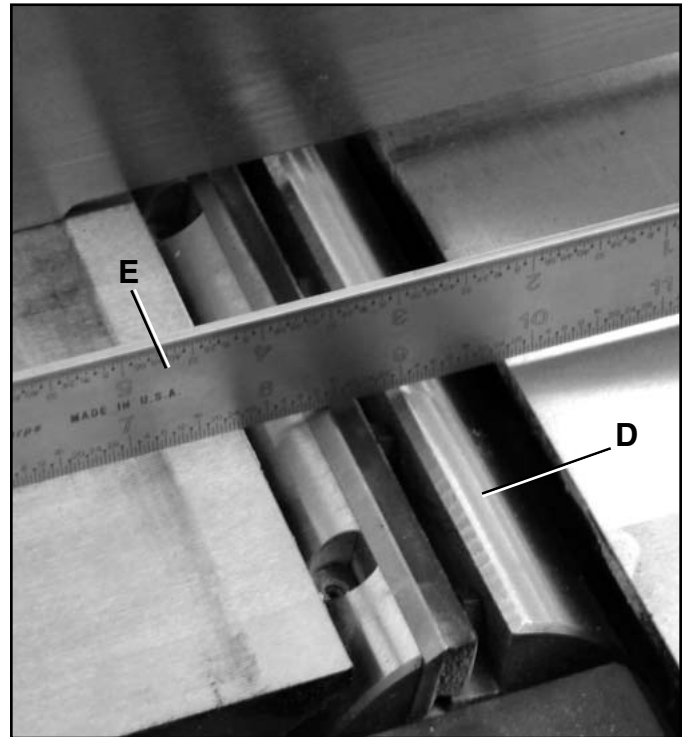

- Rotate the cutterhead by hand until the knife is at its highest point **at each end of the cutterhead**. To raise the knife, use an allen wrench and turn raising screw clockwise until the knife just touches the straight edge on each end and center of the cutterhead when the knife is at its highest point. When you are certain the knife is adjusted properly, tighten the four locking screws by turning them counterclockwise.
- Adjust the remaining two knives in the same manner. **MAKE CERTAIN THAT ALL KNIVES ARE SECURELY FASTENED IN CUTTERHEAD BEFORE TURNING ON POWER.**
- Replace cutterhead guard.

TROUBLESHOOTING GUIDE

Motor and Machine Operation

PROBLEM	LIKELY CAUSE(S)	SOLUTION
Motor will not start.	<ol style="list-style-type: none"> 1. Low voltage. 2. Open circuit in motor or loose connections. 	<ol style="list-style-type: none"> 1. Check power line for proper voltage. 2. Inspect all lead connections on motor for loose or open connections. Refer to Fig. 16, page 22 for proper connection procedure.
Fuses or circuit breakers blow.	<ol style="list-style-type: none"> 1. Short circuit in line cord or plug. 	<ol style="list-style-type: none"> 1. Repair or replace cord or plug for damaged insulation and shorted wires
Motor fails to develop full power (output of motor decreases rapidly with decrease in voltage at motor terminals).	<ol style="list-style-type: none"> 1. Power supply circuit overloaded with lights, appliances, and other motors. 2. Undersized wires or circuits too long. 	<ol style="list-style-type: none"> 1. Reduce load on circuit. 2. Increase wire sizes or reduce length of the circuit.
Motor overheats.	<ol style="list-style-type: none"> 1. Motor overloaded during operation. 2. Air circulation through the motor restricted. 	<ol style="list-style-type: none"> 1. Reduce load on motor; take lighter cuts. 2. Clean out motor to provide normal air circulation.
Motor stalls or shuts off during a cut.	<ol style="list-style-type: none"> 1. Motor overloaded during operation. 2. Short circuit in motor or loose connections. 3. Circuit breaker tripped. 	<ol style="list-style-type: none"> 1. Reduce load on motor; take lighter cuts. 2. Repair or replace connections on motor for loose or shorted terminals or worn insulation. 3. Install correct circuit breaker; reduce number of machines running on that circuit (circuit overload).
Blade slows when cutting or makes a squealing noise, especially on start-up.	<ol style="list-style-type: none"> 1. V-belt loose. 2. V-belt worn out. 	<ol style="list-style-type: none"> 1. Tighten V-belt. 2. Replace V-belt.
Loud, repetitious noise coming from machine.	<ol style="list-style-type: none"> 1. Pulley setscrews or keys are missing or loose. 2. Motor fan is hitting the cover. 3. V-belts are damaged. 	<ol style="list-style-type: none"> 1. Inspect keys and setscrews. Replace or tighten if necessary. 2. Adjust fan cover mounting position, tighten fan, or shim fan cover. 3. Replace V-belts.
Vibration when running or cutting.	<ol style="list-style-type: none"> 1. Loose or damaged knife. 2. Damaged V-belt. 3. Worn cutterhead bearings. 	<ol style="list-style-type: none"> 1. Tighten or replace knife. 2. Replace. 3. Check/replace cutterhead bearings.

Table

PROBLEM	LIKELY CAUSE(S)	SOLUTION
Tables are hard to adjust.	<ol style="list-style-type: none"> 1. Table lock is engaged or partially engaged. 	<ol style="list-style-type: none"> 1. Completely loosen the table lock.

Cutting

PROBLEM	LIKELY CAUSE(S)	SOLUTION
Excessive snipe (gouge in the end of the board that is uneven with the rest of the cut).	<ol style="list-style-type: none"> 1. Outfeed table is set too low. 2. Operator pushing down on end of workpiece. 	<ol style="list-style-type: none"> 1. Align outfeed table with cutterhead knife at top dead center. 2. Reduce/eliminate downward pressure on that end of workpiece.
Workpiece stops at the beginning of the cut.	<ol style="list-style-type: none"> 1. Outfeed table is set too high. 	<ol style="list-style-type: none"> 1. Align outfeed table with cutterhead knife at top dead center.
Chipping.	<ol style="list-style-type: none"> 1. Knots or conflicting grain direction in wood. 2. Nicked or chipped blades. 3. Feeding workpiece too fast. 4. Taking too deep of a cut. 	<ol style="list-style-type: none"> 1. Inspect workpiece for knots and grain; only use clean stock. 2. Adjust one of the nicked knives sideways; replace knives. 3. Slow down the feed rate. 4. Take a smaller depth of cut. (Always reduce cutting depth when surface planing or working with hard woods.)
Fuzzy grain.	<ol style="list-style-type: none"> 1. Wood may have high moisture content. 2. Dull knives. 	<ol style="list-style-type: none"> 1. Check moisture content and allow to dry if moisture is too high. 2. Replace knives.
Long lines or ridges that run along the length of the board.	<ol style="list-style-type: none"> 1. Nicked or chipped knives. 	<ol style="list-style-type: none"> 1. Adjust one of the nicked knives sideways; replace knives.
Uneven cutter marks, wavy surface, or chatter marks across the face of the board.	<ol style="list-style-type: none"> 1. Feeding workpiece too fast. 2. Knives not adjusted at even heights in the cutterhead. 	<ol style="list-style-type: none"> 1. Slow down the feed rate. 2. Adjust the knives so they are set up evenly in the cutterhead.
Board edge is concave or convex after jointing.	<ol style="list-style-type: none"> 1. Board not held with even pressure on infeed and outfeed table during cut. 2. Board started too uneven. 3. Board has excessive bow or twist along its length. 4. Insufficient number of passes. 	<ol style="list-style-type: none"> 1. Hold board with even pressure as it moves over the cutterhead. 2. Take partial cuts to remove the extreme high spots before doing a full pass. 3. Surface plane one face so there is a good surface to position against the fence. 4. It may take 3 to 5 passes to achieve a perfect edge, depending on the starting condition of the board and the depth of cut.
Uneven cut or breakout when rabbeting.	<ol style="list-style-type: none"> 1. Uneven feed rate. 2. Depth of cut too deep. 3. Knives not adjusted evenly with each other in the cutterhead. 4. Nicked or chipped knives. 	<ol style="list-style-type: none"> 1. Feed the board evenly and smoothly during the cut. 2. Raise the infeed table to take a smaller depth of cut. Never exceed 1/16" per pass when rabbeting. 3. Adjust the knives so they are set up evenly in the cutterhead. 4. Adjust one of the nicked knives sideways; replace knives.

PARTS

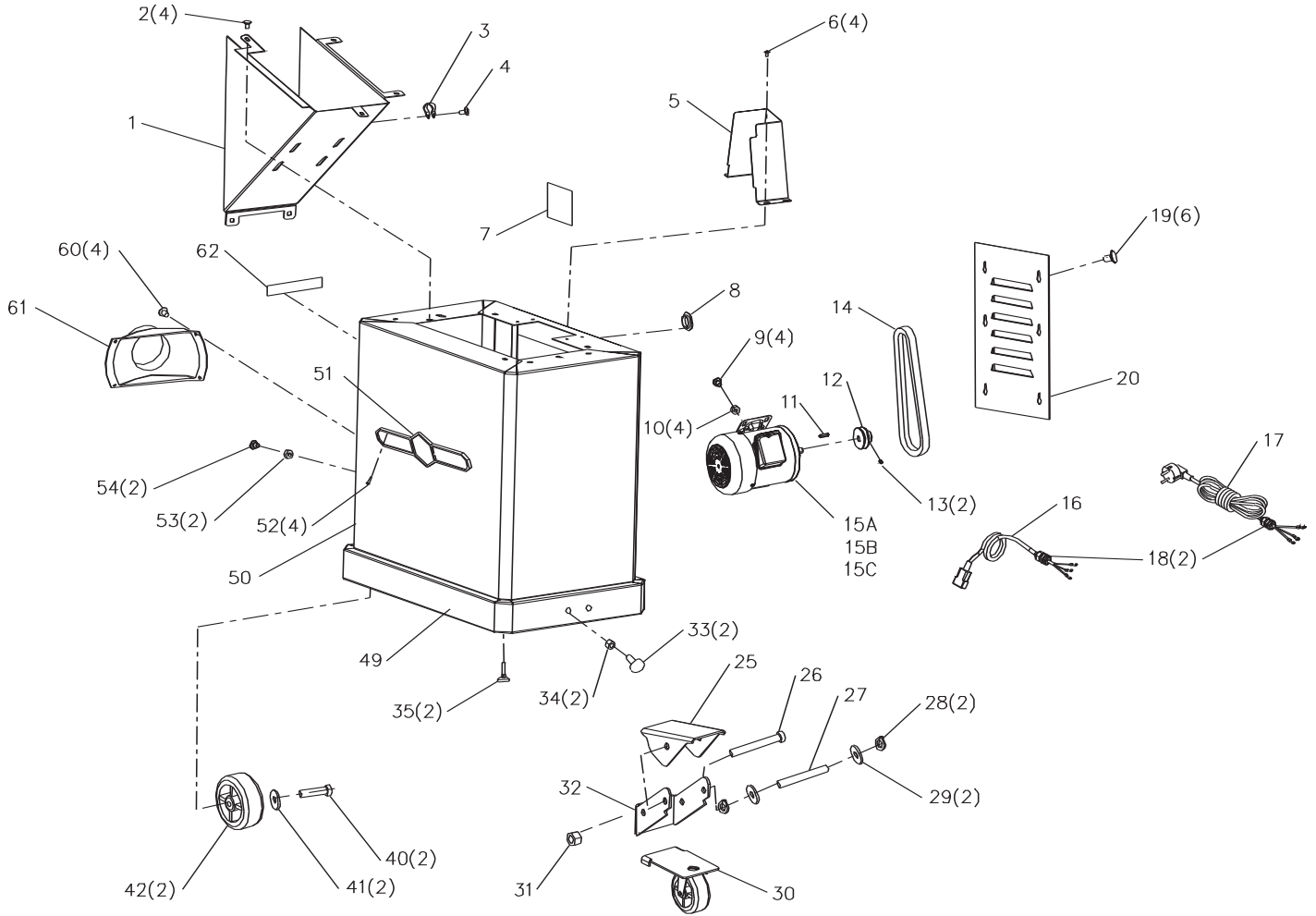

KEY NO.	PART NO.	DESCRIPTION	QTY.	KEY NO.	PART NO.	DESCRIPTION	QTY.
1	OR72909	MOTOR BRACKET	1	25	OR72919	FOOT PEDAL	1
2	OR93380	M8 x 15mm HEX SOC SET SCREW	4	26	OR91502	5/16-18 x 4" HEX HD SCREW	1
3	OR72910	CABLE CLAMP	1	27	OR72920	PIN	1
4	OR90761	M5 x 10mm PAN HD SCREW	1	28	OR94773	EXT. RET. RING 1/2"	2
5	OR72911	PULLEY GUARD	1	29	OR91504	1/2" FLAT WASHER	2
6	OR94769	M6 x 10mm PAN HD FLANGE SCREW	4	30	OR72921	CASTER ASSY	1
7	OR70327	SPEC LABEL	1	31	OR94774	5/16-18 LOCK NUT	1
8	OR72912	INSULATOR	1	32	OR72922	REAR WHEEL BRACKET	1
9	OR94770	M8 x 16mm CARRIAGE BOLT	4	33	OR94775	M8 x 20mm CARRIAGE BOLT	2
10	OR94771	M8 HEX FLANGE NUT	4	34	OR94771	M8 HEX FLANGE NUT	2
11	OR90219	5mm x 5mm x 30mm KEY	1	35	OR72923	LEVELING PAD	2
12	OR72913	PULLEY	1	40	OR91497	M8 x 50mm HEX HD SCREW	2
13	OR90222	M6 x 10mm HEX SOC SET SCREW	2	41	OR90059	M8 FLAT WASHER	2
14	OR72914	BELT(A-965)	1	42	OR72924	WHEEL	2
15A	OR70432	MOTOR ASSEMBLY 1.5HP	1	50	OR72925	CABINET	1
15B	OR70379	MOTOR SPEC PLATE (NOT SHOWN)	1	51	OR70484	NAMEPLATE	1
15C	OR72915	CAPACITOR ASSY (NOT SHOWN)	1	52	OR93823	RIVET	4
16	OR72916	SWITCH CORD	1	53	OR94771	M8 HEX FLANGE NUT	2
17	OR72917	POWER CORD	1	54	OR94776	M8 x 16mm CARRIAGE BOLT	2
18	OR70141	STRAIN RELIEF(7P-2)	2	60	OR94777	M6 x 8mm PAN HD SCREW	4
19	OR94772	M6 x 20mm PAN HD FLANGE SCREW	6	61	OR72926	DUST PORT	1
20	OR72918	BACK COVER	1	62	OR72927	WARNING LABEL	1

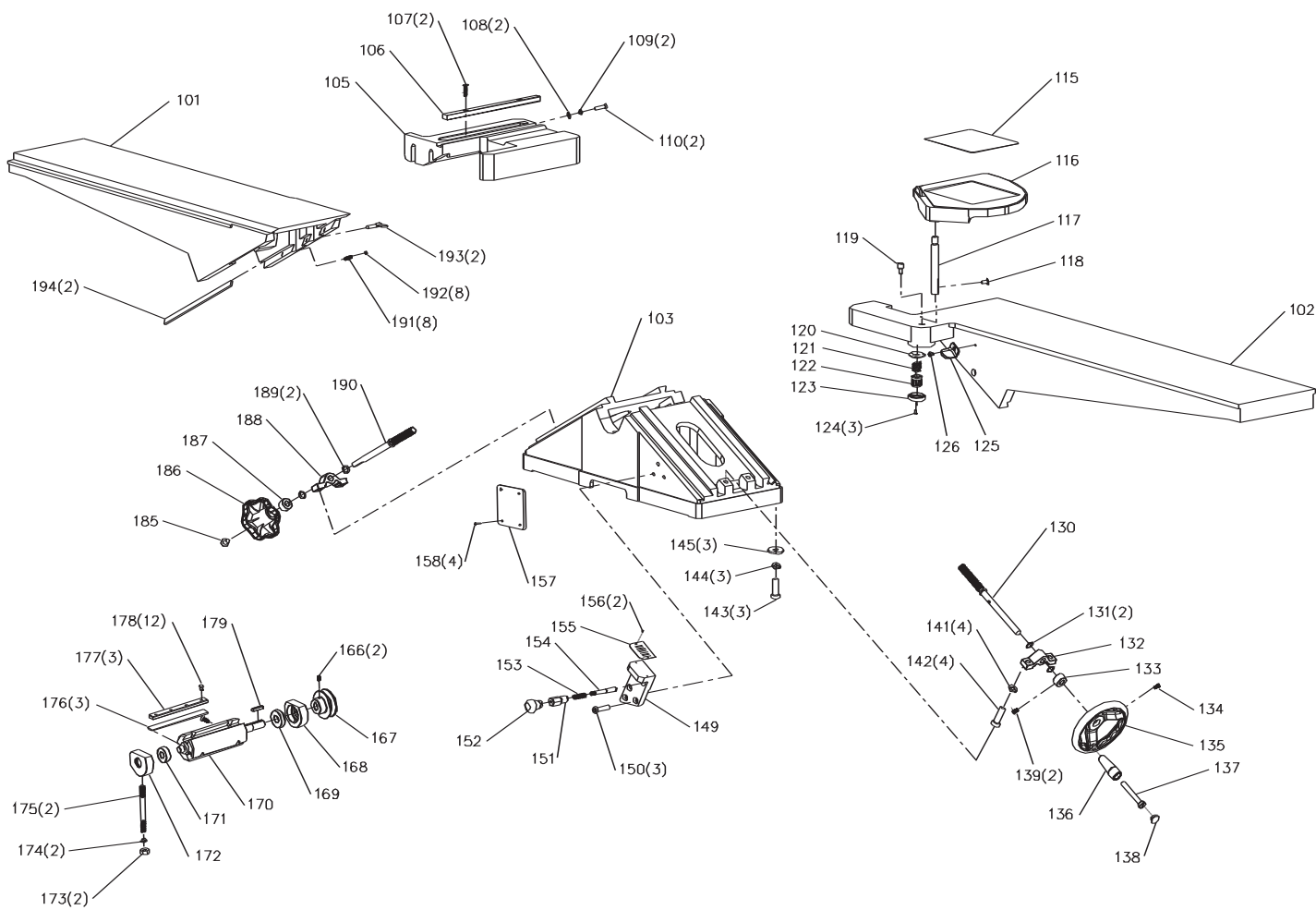

KEY NO.	PART NO.	DESCRIPTION	QTY.	KEY NO.	PART NO.	DESCRIPTION	QTY.
100	OR72928	BASE ASSY, CONST. OF : REF 101 TO REF 103	1	145	OR90230	M10 FLAT WASHER	3
101	XXXXXXX	OUTFEED TABLE (ONLY AVAIL. AS AN ASSEMBLY)	1	149	OR72945	DEPTH BLOCK	1
102	XXXXXXX	INFEED TABLE (ONLY AVAIL. AS AN ASSEMBLY)	1	150	OR91821	M8 x 20mm HEX SOC SET SCREW	3
103	XXXXXXX	BASE (ONLY AVAILABLE AS AN ASSEMBLY)	1	151	OR72946	PLUNGER HOUSING	1
105	OR72929	FENCE MOUNT	1	152	OR72947	KNOB	1
106	OR94778	KEY	1	153	OR94784	SPRING	1
107	OR94779	M5 x 15mm HEX SOC SET SCREW FLAT HD	2	154	OR72948	PLUNGER	1
108	OR90230	M10 FLAT WASHER	2	155	OR72949	SCALE	1
109	OR90227	M10 LOCK WASHER	2	156	OR93823	RIVET	2
110	OR94780	M10 x 40mm HEX SOC CAP SCREW	2	157	OR72950	NAMEPLATE	1
115	OR72930	WARNING LABEL	1	158	OR93823	RIVET	4
116	OR72931	CUTTER HEAD GUARD	1	165	OR72951	CUTTER HEAD ASSY, CONST. OF: REF 166 TO REF 179	1
117	OR72932	GUARD PIN	1	166	OR90222	M6 x 10mm HEX SOC SET SCREW	2
118	OR90507	M5 x 8mm PAN HD SCREW	1	167	OR72952	PULLEY	1
119	OR72933	PIN	1	168	OR72953	BEARING SUPPORT	1
120	OR72934	RETAINER	1	169	OR94785	BEARING(6203-2Z)	1
121	OR94781	SPRING	1	170	OR72954	CUTTER HEAD	1
122	OR72935	KNOB	1	171	OR94786	BEARING(6202-2Z)	1
123	OR72936	KNOB RETAINER	1	172	OR72955	BEARING SUPPORT	1
124	OR91775	M4 x 15mm PAN HD SCREW	3	173	OR90228	M10 HEX NUT	2
125	OR72937	POINTER	1	174	OR90227	M10 LOCK WASHER	2
126	OR91774	M4 x 10mm PAN HD SCREW	1	175	OR72956	ARBOR SCREW	2
130	OR72938	ELEVATION SCREW	1	176	OR72957	KNIFE	3
131	OR94782	COPPER WASHER	2	177	OR72958	BLADE LOCK WEDGE	3
132	OR72939	CLAMP	1	178	OR94782	M6 x 8mm SQUARE HEAD SCREW	12
133	OR72940	COLLAR	1	179	OR90219	5mm x 5mm X 30mm KEY	1
134	OR92278	M8 x 10mm HEX SOC SET SCREW	1	185	OR93930	M6 x 10mm PAN HEAD SCREW	1
135	OR72941	INFEED HAND WHEEL	1	186	OR72959	HAND WHEEL	1
136	OR72942	KNOB	1	187	OR72940	COLLAR	1
137	OR72943	KNOB BOLT	1	188	OR72939	CLAMP	1
138	OR72944	KNOB END CAP	1	189	OR94782	COPPER WASHER	2
139	OR90788	M6 x 8mm HEX SOC SET SCREW	2	190	OR72962	ELEVATION SCREW	1
141	OR91500	M8 LOCK WASHER	4	191	OR90236	M6 x 25mm HEX SOC SET SCREW	8
142	OR94783	M8 x 55mm HEX SOC SET SCREW	4	192	OR90235	M6 HEX NUT	8
143	OR90777	M10 x 25mm HEX SOC SET SCREW	3	193	OR94788	M6 WING SCREW	2
144	OR90227	M10 LOCK WASHER	3	194	OR72963	GIB	2

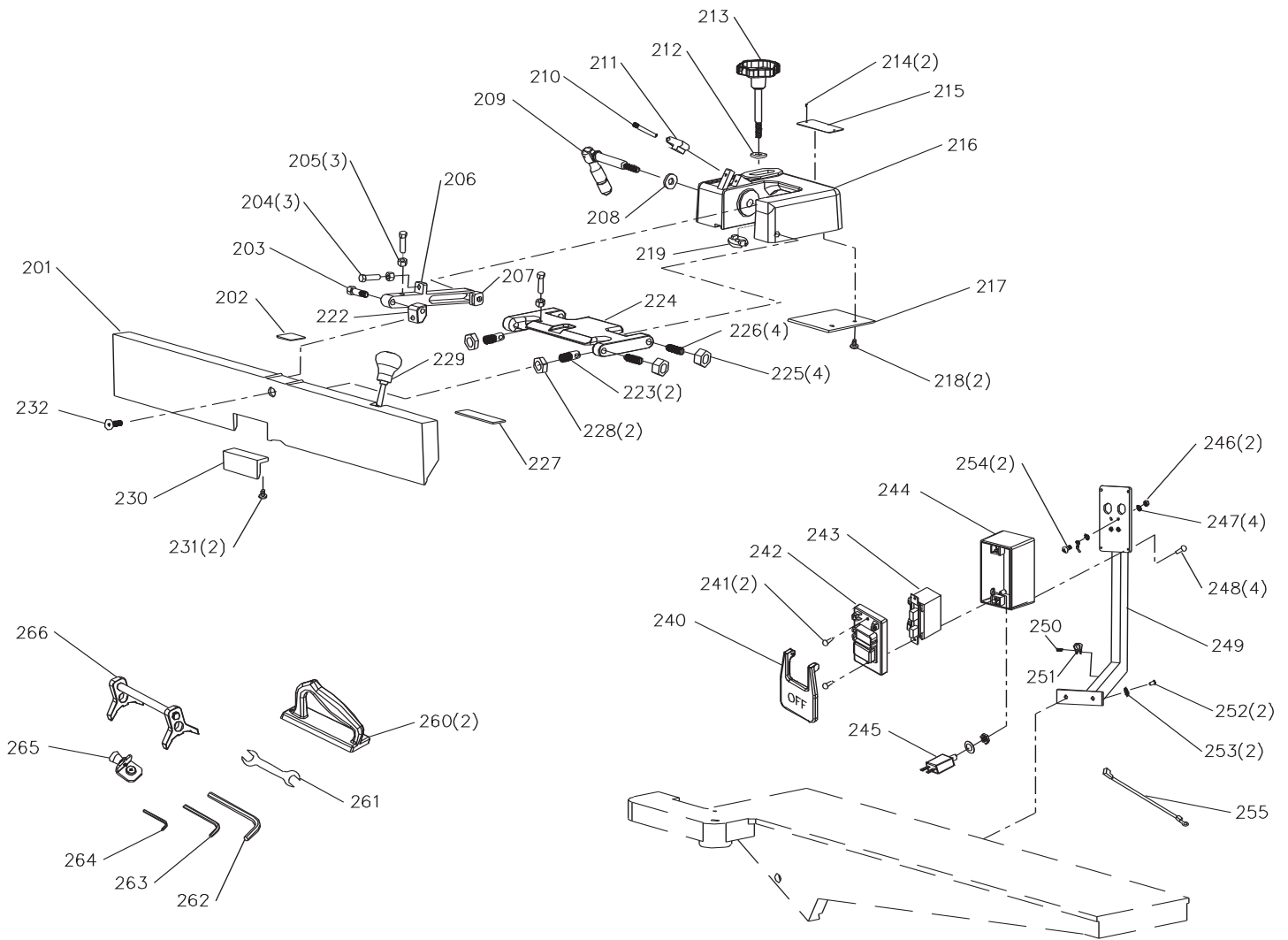

KEY NO.	PART NO.	DESCRIPTION	QTY.	KEY NO.	PART NO.	DESCRIPTION	QTY.
200	OR72964	FENCE ASSY, CONST. OF : REF 201 TO REF 232	1	231	OR91758	M6 x 15mm HEX SOC SET SCREW	2
201	OR72965	FENCE	1	232	OR94792	M8 x 42 mm HEX SOC SET SCREW	1
202	OR72966	ROTATION LABEL	1	239	OR72982	SWITCH ASSY, CONST OF : REF 240 TO REF 245	
203	OR94789	SHOULDER BOLT	1	240	OR72983	SWITCH PADDLE	1
204	OR94348	M8 x 35mm HEX HD SCREW	3	241	OR93900	M4 x 25mm ROUND HD TAP SCR	2
205	OR90307	M8 HEX NUT	3	242	OR72984	SWITCH COVER ASSY	1
206	OR72967	SLIDE POLE	1	243	OR72985	SWITCH	1
207	OR94790	SQUARE NUT	1	244	OR72986	SWITCH BOX	1
208	OR90304	M12 FLAT WASHER	1	245	OR72987	RESET SWITCH	1
209	OR72968	HANDLE ASSEMBLY	1	246	OR90381	M5 HEX NUT	2
210	OR94791	ANGEL SCREW	1	247	OR90362	M5 EXT TOOTH WASHER	4
211	OR72969	STOP PLATE	1	248	OR91828	M4 x 16mm ROUND HD TAP SCR	4
212	OR91504	1/2" FLAT WASHER	1	249	OR72988	SWITCH BRACKET	1
213	OR72970	KNOB	1	250	OR90507	M5 x 10mm PAN HD SCREW	1
214	OR93823	RIVET	2	251	OR72989	CABLE CALMP	1
215	OR72971	CUTTER HEAD ROTATION LABEL	1	252	OR91758	M6 x 15mm HEX SOC SET SCREW	2
216	OR72972	FENCE SLIDE MOUNT	1	253	OR94793	M6 EXT TOOTH WASHER	2
217	OR72973	PLATE	1	254	OR90507	M5 x 8mm PAN HD SCREW	2
218	OR90507	M5 x 8mm PAN HD SCREW	2	255	OR72990	JUMPER WIRE(BLACK)	1
219	OR92974	LOCK COLLAR	1	260	OR72991	PUSH BLOCK	2
222	OR72975	HANDLE NUT	1	261	OR72992	8mm x 10mm WRENCH	1
223	OR72976	PIVOT STUD	2	262	OR90292	8mm HEX WRENCH	1
224	OR72977	FENCE PIVOT PLATE	1	263	OR91728	5mm HEX WRENCH	1
225	OR90228	M10 HEX NUT	4	264	OR90290	3mm HEX WRENCH	1
226	OR72978	PIVOT SCREW	4	265	OR72993	CUTTER HEAD LOCK	1
227	OR72979	INFEED LABEL	1	266	OR72994	KNIFE SETTING GAGE	1
228	OR90280	M12 HEX NUT	2	300	OR72995	MANUAL (NOT SHOWN)	1
229	OR72980	KNOB	1	301	OR72996	MANUAL FRENCH (NOT SHOWN)	1
230	OR72981	PROTECTION BLOCK	1	302	OR72997	MANUAL SPANISH (NOT SHOWN)	1

◆ NOTES ◆



STEEL CITY TOOL WORKS

www.steelcitytoolworks.com

1-877-SC4-TOOL

(1-877-724-8665)

5 Year Warranty

