

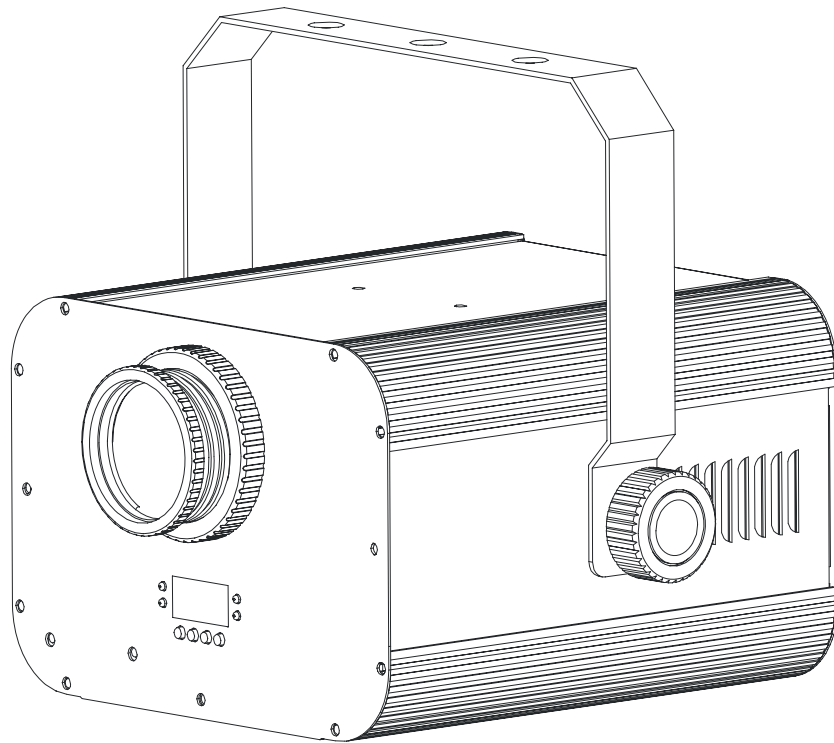

ColorTec 250



LED-CC60

User Guide

Please read the instruction carefully before using

Contents

1. Safety Instructions.....	2
2. Features	3
3. Technical Specifications.....	3
4. How To Set The Unit	4
4.1 Control Panel.....	4
4.2 Main Function	5
5. How To Set The Unit	10
5.1 Master/Slave Built In Preprogrammed Function	10
5.2 Easy Controller	11
5.3 DMX Controller.....	11
5.4 DMX 512 Configuration.....	12
5.5 DMX512 Connection.....	13
6. Troubleshooting	14
7. Cleaning And Maintenance.....	15

1. Safety Instructions



Please read the instructions carefully which includes important information about the installation, operation and maintenance.

- Please keep this User Guide for future consultation. If you sell the fixture to another user, be sure that they also receive this instruction booklet.



DANGER!
Safety hazard.
Risk of severe injury or death.



DANGER!
Hazardous voltage. Risk of lethal or severe electric shock.



WARNING!
Fire hazard.



WARNING!
LED light emission. Risk of eye injury.



WARNING!
Burn hazard. Hot surface. Do not touch.



WARNING! Refer to user manual.

Cautions:

- All fixtures are intact from the manufacturer, please operate follow up the user manual, artificial fault are not under guarantee repair.
- Unpack and check carefully there is no transportation damage before using the fixture.
- Be sure that no ventilation slots are blocked, otherwise the fixture will be overheated.
- Before operating, ensure that the voltage and frequency of power supply match the power requirements of the fixture.
- Use in a dry location.
- It's important to ground the yellow/green conductor to earth in order to avoid electric shock.
- Maximum ambient temperature is 40°C. Don't operate it where the temperature is higher than this.
- First run, there will be smoke or smells, and all disappearing a few minutes later.
- Make sure there are no flammable materials close to the fixture while operating, as it is fire hazard.
- Look over power wires carefully, replace immediately if there is any damage.
- Fixture surface temperature may reach up to 65°C. Don't touch the housing bare-hand during its operation.
- Never run on for a long time lest shortening lifespan.
- Do not operate in dirty and dusty environment, also cleaning fixtures regularly.
- Do not allow children to operate the fixture.
- Never turn on and off the fixture time after time.

- The housing, the lenses, or the ultraviolet filter must be replaced if they are visibly damaged.
- Do not open the fixture as there are no user serviceable parts inside. Never try to repair the fixture by yourself. Repairs carried out by unskilled people can lead to damage or malfunction. Please contact the nearest authorized technical assistance center.
- Disconnect the mains power if the fixture is not used for a long time.

For 230V 50Hz power supply, maximum fixtures that can be connected on one power cable is 7.

2. Features

- Featuring 60W high powerful LED, one color wheel for creating different saturated colors. Work as a Color Changer.
- Three Operation Modes: DMX, Master / Slave and Sound Active
DMX 512 Control Mode: 3 / 8 channels
- Great built-in lighting shows under Master / Slave mode triggered by music
- 70~100% full range dimmer and variable strobe speed
- Optional easy controller CA-8 or CA-9 RTX for instant lighting shows at your fingers
- Two different angles selectable, 9° as standard and 14° as an accessory
- Ideal for restaurants, clubs, bars, discos, parties, mobile Djs and more

3. Technical Specifications

- **Input Voltage :** AC 230V, 50Hz
- **Power Consumption:** 95W
- **Light Source:** 1 × 60W LED
- **Fuse:** T 6.3A
- **Dimension:** 268×266×233mm
- **Weight:** 4.2kgs

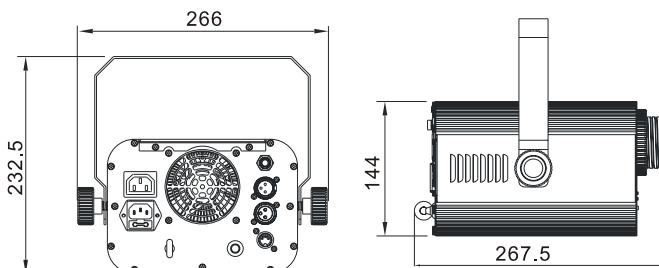

4. How To Set The Unit

4.1 Control Panel

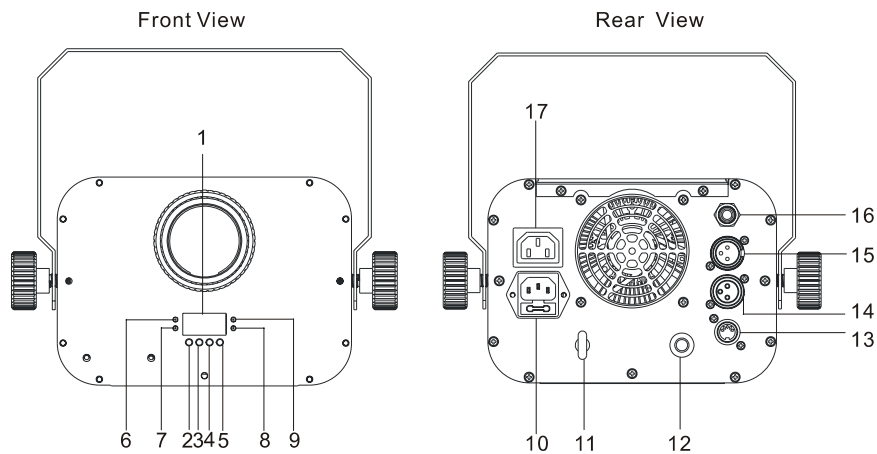

1. Display

Show the various menus and the selected functions.

Button

2.MENU	To select the programming functions
3.DOWN	To go backward in the selected functions
4.UP	To go forward in the selected functions
5.ENTER	To confirm the selected functions

LED

6.DMX	On	DMX input present
7.MASTER	On	Master Mode
8.SOUND	Flashing	Sound activation
9.SLAVE	On	Slave Mode

10. **Power in:** Power connection to power source.

11. **Safety hook:** Used to connect safety cable to.

12. **Microphone:** Receive music for the sound active.

13. **Only for wireless receiver:** Connect with CA-9 RTX to control the unit for Stand by, Function and Mode function.

14. **DMX in:** For DMX 512 link, use 3-pin XLR plug cable to input DMX signal.

15. **DMX out:** For DMX 512 link, use 3-pin XLR plug cable to link the next fixture.

16. **Only for remote control:** Connect with CA-8 to control the unit for Stand by, Function and Mode function.

17. **Power out:** Connect to supply mains power for the next fixture.

4.2 Main Function

To select any of the given functions, press the **MENU** button up to when the required one is showing on the display. Select the function by the **ENTER** button and the display will blink. Use the **DOWN** and **UP** button to change the mode. Once the required mode has been selected, press the **ENTER** button to setup or it will automatically return to the main functions without any change after idling 8 seconds. To go back to the functions without any change press the **MENU** button. The main functions are showing below:

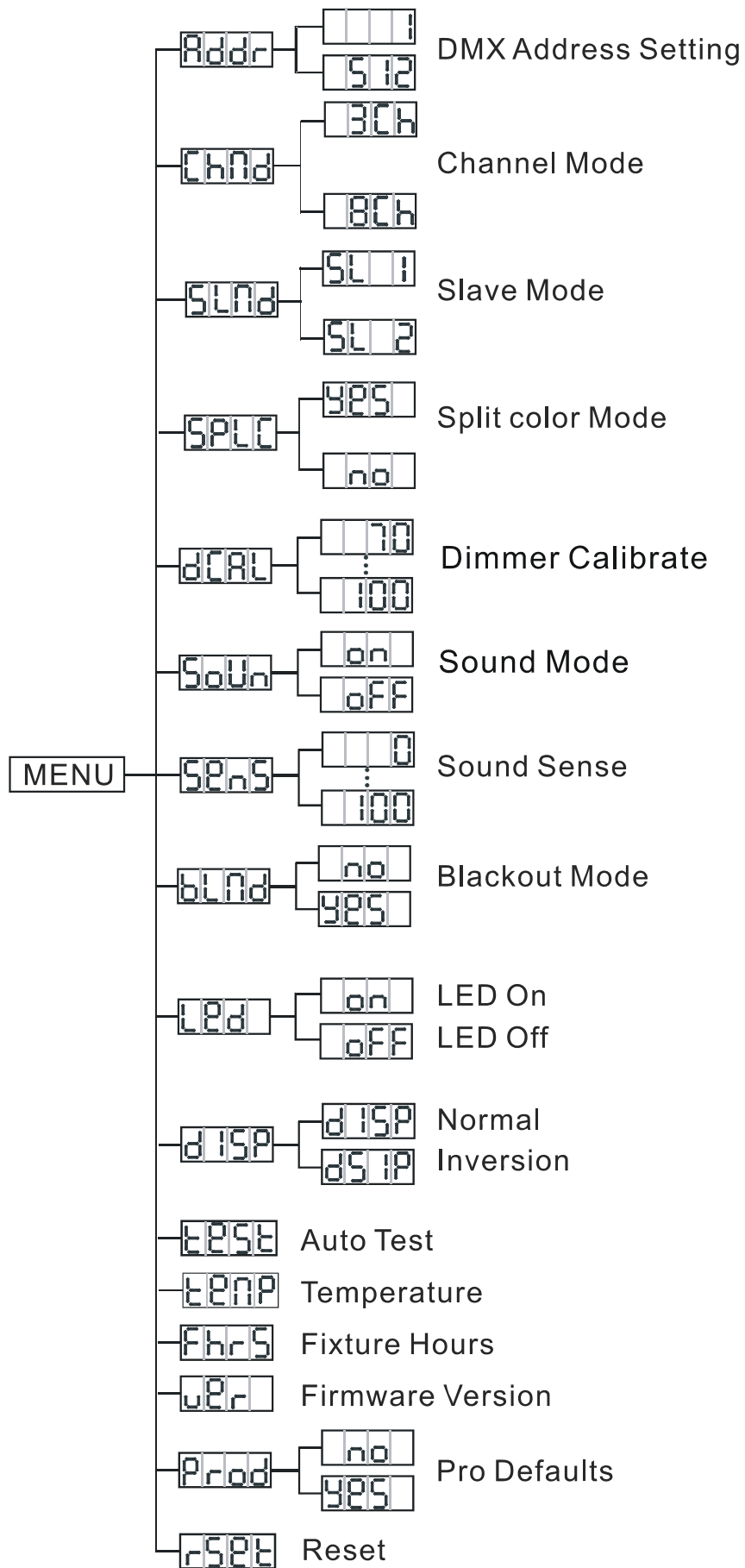

Addr DMX 512 Address Setting

Select the **Addr**, press the **ENTER** button and the display will blink. Use the **DOWN** and **UP** button to change the DMX512 address. Once the address has been selected, press the **ENTER** button to setup or automatically return to the main functions without any change after 8 seconds. To go back to the functions without any change press the **MENU** button again.

Chnd Channel Mode

Select the **Chnd**, press the **ENTER** button and the display will blink. Use the **DOWN** and **UP** button to select the **3CH** (3 channel) or **8CH** (8 channel) mode. Once the channel mode has been selected, press the **ENTER** button to setup, to go back to the functions without any change press the **MENU** button again. Hold and press the **MENU** button about one second or wait for one minute to exit the menu mode.

SLnd Slave Mode

Select the **SLnd**, press the **ENTER** button and the display will blink. Use the **DOWN** and **UP** button to select the **SL1** (normal) or **SL2** (2 light show) mode. Once the mode has been selected, press the **ENTER** button to setup, to go back to the functions without any change press the **MENU** button again. Hold and press the **MENU** button about one second or wait for one minute to exit the menu mode.

SPLC Split Color Mode

Select the **SPLC**, press the **ENTER** button and the display will blink. Use the **DOWN** and **UP** button to select the **YES** (Split color mode) or **no** (normal). Once the mode has been selected, press the **ENTER** button to setup, to go back to the functions without any change press the **MENU** button again. Hold and press the **MENU** button about one second or wait for one minute to exit the menu mode.

dcAL Dimmer Calibrate

Select the **dcAL**, press the **ENTER** button and the display will blink. Use the **DOWN** and **UP** button to calibrate the dimmer for a maximum output from **070** (limited to 70% of the really max. output) to **100** (maximum output is not limited). Once the mode has been selected, press the **ENTER** button to setup, to go back to the functions without any change press the **MENU** button again. Hold and press the **MENU** button about one second or wait for one minute to exit the menu mode.

SOOn Sound Mode

Select the **SOOn** is showing on the display. Pressing the **ENTER** button and the display will blink. Use the **DOWN** and **UP** button to select the **on** (sound on) or **off** (sound off) mode. Once the mode has been selected, press the **ENTER** button to setup or automatically return to the main functions without any change after 8 seconds. To go back to the functions without any change press the **MENU** button again.

SEnS Sound Sense

Select the **SEnS**, press the **ENTER** button and the display will blink. Use the **DOWN** and **UP** button to adjust the sound sensitivity between **000** and **100**. Once selected, press the **ENTER** button to setup, to go back to the functions without any change press the **MENU** button again. Hold and press the **MENU** button about one second or wait for one minute to exit the menu mode.

BLnD Blackout Mode

Select the **BLnD**, press the **ENTER** button and the display will blink. Use the **DOWN** and **UP** button to select the **yes** (yes blackout) or **no** (no blackout) mode. Once selected, press the **ENTER** button to setup or automatically return to the main functions without any change after 8 seconds. To go back to the functions without any change press the **MENU** button again.

LEd LED Display

Select the **LEd**, press the **ENTER** button and the display will blink. Use the **DOWN** and **UP** button to select the **on** (LED on) or **off** (LED off). Once the mode has been selected, press the **ENTER** button to setup or automatically return to the main functions without any change after 8 seconds. To go back to the functions without any change press the **MENU** button again.

dISP Display Inversion

Select the **dISP**, press the **ENTER** button and the display will blink. Use the **DOWN** and **UP** button to select the **dISP** (normal) or **dSPi** (display inversion). Once selected, press the **ENTER** button to setup or automatically return to the main functions without any change after 8 seconds. To go back to the functions without any change press the **MENU** button again.

tEst Auto Test

Select the **tEst**, press the **ENTER** button and the fixture will run the built-in program to test the fixture. To go back to the functions press the **MENU** button again.

tEMP Temperature Test

Select the **tEMP**, press the **ENTER** button and the display will show the temperature of the unit. To go back to the functions press the **MENU** button again.

FhrS Fixture Hours

Select the **FhrS**, press the **ENTER** button and the display will show the number of working hours of the unit. To go back to the functions press the **MENU** button again.

vEr Software version

Select the **vEr**, press the **ENTER** button and the display will show the version of software of the unit. To go back to the functions press the **MENU** button again. Hold and press the **MENU** button about one second or wait for one minute to exit the menu mode.

Prod PRO Defaults

Select the **Prod**, press the **ENTER** button and the display will blink. Use the **DOWN** and **UP** button to select the **985** (run built-in program to set the fixture to factory settings) or **no**. Press the **ENTER** button to setup, to go back to the functions without any change press the **MENU** button again. Hold and press the **MENU** button about one second or wait for one minute to exit the menu mode.

rS2t Reset

Press the **MENU** button to show the **rS2t** on the display. Press the **ENTER** button and all channels of the unit will return to their standard position.

5. How To Set The Unit

You can operate the unit in three ways:

1. By master/slave built-in preprogram function
2. By easy controller
3. By universal DMX controller

No need to turn the unit off when you change the DMX address, as new DMX address setting will be effected at once. Every time you turn the unit on, it will show the **cc60** on the display and move all the motors to their 'home' position and you may hear some noises for about 20 seconds. After that the unit will be ready to receive DMX signal or run the built-in programs.

5.1 Master/Slave Built In Preprogrammed Function

By linking the units in master/slave connection, the first unit will control the other units to give an automatic, sound activated, synchronized light show. This function is good when you want an instant show.

2-light show

In **SLND** (slave mode), **SL1** means the unit works normally and **SL2** means 2-light show. In order to create a great light show, you can set **SL2** on the second unit to get contrast movement to each other, even if you have two units only.

5.2 Easy Controller

The easy remote control is used only in master/slave mode. By connecting to the 1/4" microphone jack of the first unit, you will find that the remote control on the first unit will control all the other units functions press the MENU button again.

Stand By	Blackout the unit	
Function	1. Sync. Strobe 2. Async strobe 3. Sound Strobe	Select Color
Mode	Sound (LED OFF)	Color (LED On)

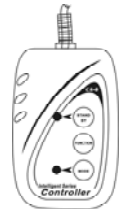

5.3 DMX Controller

An universal DMX controller to control the units, you have to set DMX address from 1 to 512 channel so that the units can receive DMX signal.





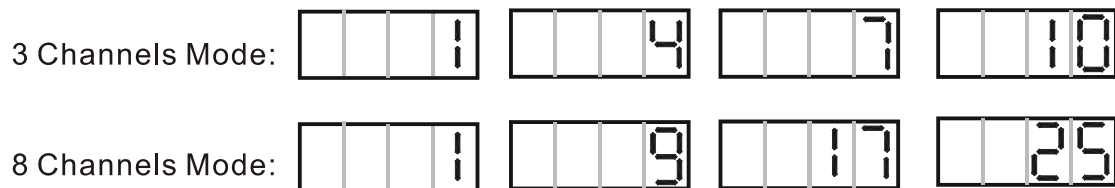



Press the **MENU** button up to when the **Addr** is showing on the display. Press the **ENTER** button and the display will blink. Use the **DOWN** and **UP** button to change the DMX512 address. Once the address has been selected, press and keep the **ENTER** button pressed up to when the display stops blinking or storing automatically 8 seconds later. To go back to the functions without any change press the **MENU** button again.

If you use please refer to the following diagram to address your DMX512 channel for the first 4 units.

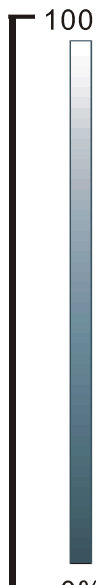

5.4 DMX 512 Configuration

3/8 Channels Mode:

DMX512 Configurations								
3 Channels Mode								
Ch1		Ch2			Ch3			
Color Wheel (Normal)	Color Wheel (Spilt Color Mode)	Dimmer			Strobe			
255 Rotation Fast  Slow 128 Rotation 113-127 Color8 099-112 Color7 085-098 Color6 071-084 Color5 057-070 Color4 043-056 Color3 029-042 Color2 015-028 Color1 000-014 White	255 Rotation Fast  Slow 128 Rotation 120-127 Color16 113-119 Color15 106-112 Color14 099-105 Color13 092-098 Color12 085-091 Color11 078-084 Color10 071-077 Color9 064-070 Color8 057-063 Color7 050-056 Color6 043-049 Color5 036-042 Color4 029-035 Color3 022-028 Color2 015-021 Color1 000-014 White	255 100%  0 0%			248-255 Open 240-247 Random Strobe 232-239 Open 190-231 Fast Close Slow Open 182-189 Open 140-181 Fast Open Slow Close 132-139 Open 16-131  8-15 Open 0-7 Blackout			
8 Channels Mode								
Ch1	Ch2	Ch3	Ch4	Ch5		Ch6	Ch7	Ch8
Null	Null	Strobe	Null	Color Wheel (Normal)	Color Wheel (Spilt Color Mode)	Null	Dimmer	Null
		248-255 Open 240-247 Random Strobe 232-239 Open 190-231 Fast Close Slow Open 182-189 Open 140-181 Fast Open Slow Close 132-139 Open 16-131  8-15 Open 0-7 Blackout		255 Rotation Fast  Slow 128 Rotation 113-127 Color8 099-112 Color7 085-098 Color6 071-084 Color5 057-070 Color4 043-056 Color3 029-042 Color2 015-028 Color1 000-014 White	255 Rotation Fast  Slow 128 Rotation 120-127 Color16 113-119 Color15 106-112 Color14 099-105 Color13 092-098 Color12 085-091 Color11 078-084 Color10 071-077 Color9 064-070 Color8 057-063 Color7 050-056 Color6 043-049 Color5 036-042 Color4 029-035 Color3 022-028 Color2 015-021 Color1 000-014 White		255 100%  0 0%	

5.5 DMX512 Connection

The DMX 512 is widely used in intelligent lighting control, with a maximum of 512 channels.

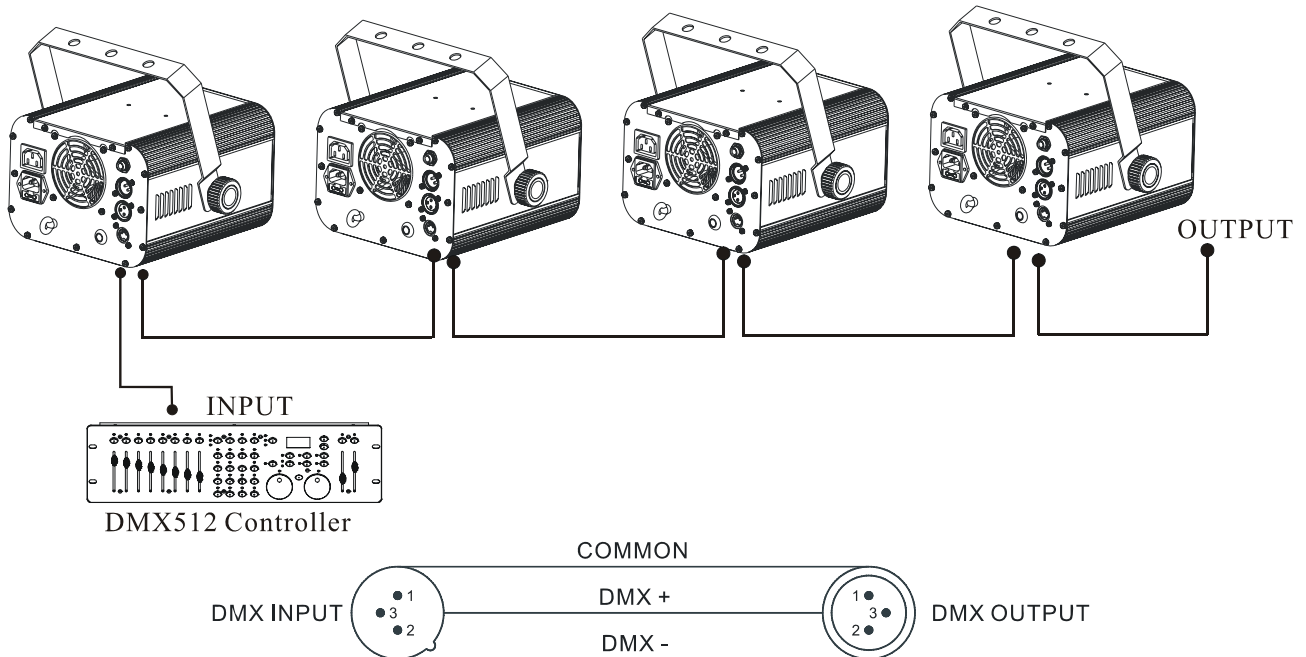

Termination reduces signal errors and to avoid signal transmission problems and interference. It is always advisable to connect a DMX terminal. (Resistance 120 ohm 1/4W) between pin2(DMX-) and pin3(DMX+) of the last fixture.



1. If you using a controller with 5 pins DMX output, you need to use a 5 to 3 pin adapter-cable.
2. At last unit, the DMX cable has to be terminated with a terminator. Solder a 120 ohm 1/4W resistor between pin 2(DMX-) and pin 3(DMX+) into a 3-pin XLR-plug and plug it in the DMX-output of the last unit.
3. Connect the unit together in a `daisy chain` by XLR plug from the output of the unit to the input of the next unit. The cable can not branched or split to a `Y` cable. DMX 512 is a very high-speed signal. Inadequate or damaged cables, soldered joints or corroded connectors can easily distort the signal and shut down the system.
4. The DMX output and input connectors are pass-through to maintain the DMX circuit, when power is disconnected to the unit.
5. Each lighting unit needs to have an address set to receive the data sent by the controller. The address number is between 0-511 (usually 0 & 1 are equal to 1).
6. The end of the DMX 512 system should be terminated to reduce signal errors.
7. 3 pin XLR connectors are more popular than 5 pin XLR.

3 pin XLR: Pin 1: GND, Pin 2: Negative signal (-), Pin 3: Positive signal (+)

5 pin XLR: Pin 1: GND, Pin 2: Negative signal (-), Pin 3: Positive signal (+)

6. Troubleshooting

Following are a few common problems that may occur during operation. Here are some suggestions for easy troubleshooting:

A. The unit does not work, no light and the fan does not work

1. Check the connection of power and main fuse.
2. Measure the mains voltage on the main connector.
3. Check the power on LED.

B. Not responding to DMX controller

1. The DMX LED should be on. If not, check DMX connectors, cables to see if link properly.
2. If the DMX LED is on and no response to the channel, check the address settings and DMX polarity.
3. If you have intermittent DMX signal problems, check the pins on connectors or on PCB of the unit or the previous one.
4. Try to use another DMX controller.
5. Check if the DMX cables run near or run alongside to high voltage cables that may cause damage or interference to DMX interface circuit.

C. Some units don't respond to the easy controller

1. You may have a break in the DMX cabling. Check the LED for the response of the master/slave mode signal.
2. Wrong DMX address in the unit. Set the proper address.

D. No response to the sound

1. Make sure the unit does not receive DMX signal.
2. Check microphone to see if it is good by tapping the microphone

E. One of the channels is not working well

1. The stepper motor might be damaged or the cable connected to the PCB is broken.
2. The motor's drive IC on the PCB might be out of condition

7. Cleaning And Maintenance

The cleaning must be carried out periodically to optimize light output. Cleaning frequency depends on the environment in which the fixture operates: moist, smoky or particularly dirty surrounding can cause greater accumulation of dirt on the fixture.

- Clean with lint-free cloth using normal glass cleaning liquid.
- Always dry the parts carefully.
- Clean the surface at least every 30 days.
- Never use alcohol or solvents.

Declaration of Conformity

We declare that our products (lighting equipments) comply with the following specification and bears CE mark in accordance with the provision of the Electromagnetic Compatibility (EMC) Directive 2004/108/EC.

EN55103-1: 2009 ; EN55103-2: 2009;
EN61000-3-2: 2006 + A1:2009 + A2:2009; EN61000-3-3: 2008.

&

Harmonized Standard

EN 60598-1:2008 + A1:2009; EN 60598-2-17:1989 + A2:1991;
EN 62471:2008; EN 62493: 2010
Safety of household and similar electrical appliances
Part 1: General requirements

Innovation, Quality, Performance