



NordicTrack[®]

9600 Treadmill

Model No. CTL82520
Model No. CTL85020

Serial No. _____

The serial number is found in the location shown below. Write the serial number in the space above.

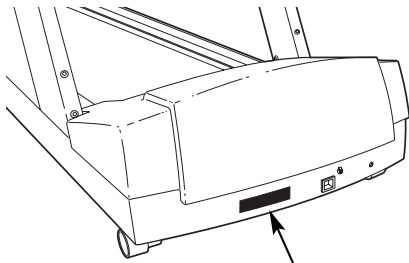

Serial Number Decal

QUESTIONS?

At FreeMotion Fitness, we're committed to providing complete customer satisfaction. For assistance, call Customer Care toll-free at:

1-800-201-2109

Mon.–Fri., 8 a.m.–5 p.m. MST

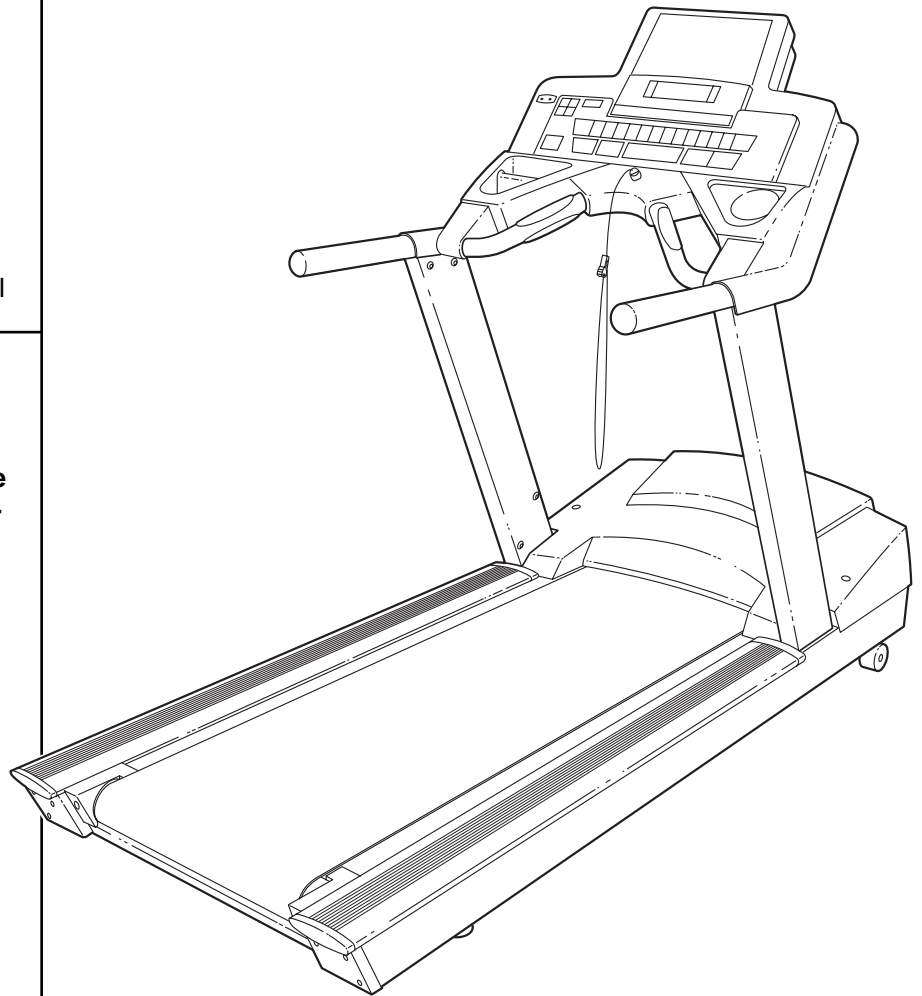

CAUTION

Read all precautions and instructions in this manual before using this equipment. Keep this manual for future reference.

USER'S MANUAL



NordicTrack[®]

9600 Treadmill

TABLE OF CONTENTS

SECTION 1

Important Precautions	3
Warning Decal Placement	5
Before You Begin	6
How to Set Up the Treadmill	7
How to Move the Treadmill	9
How to Connect the Treadmill	10
How to Connect your CD Player to the Treadmill	11
How to Upgrade your Console	12

SECTION 2

How to Use the Basic Console	13
How to Use the Workout TV Console	26

SECTION 3

Preventive Maintenance	29
Six-month Preventive Maintenance Record	31
Trouble-shooting	33

SECTION 4

Exercise Guidelines	35
-------------------------------	----

SECTION 5

Limited Warranty	39
Part List	41
Exploded Drawing	43
How to Order Replacement Parts	46

IMPORTANT PRECAUTIONS

⚠ WARNING: To reduce the risk of burns, fire, electric shock, or injury to persons, read the following important precautions and information before operating the treadmill.

1. It is the responsibility of the owner to ensure that all users of the treadmill are adequately informed of all warnings and precautions.
2. Use the treadmill only as described in this manual.
3. Place the treadmill on a level surface, with at least eight feet of clearance behind it and two feet on each side. Do not place the treadmill on a surface that blocks any air openings. To protect the floor or carpet from damage, place a mat under the treadmill.
4. Keep the treadmill indoors, away from moisture and dust. Do not place the treadmill in a garage or covered patio, or near water.
5. Do not operate the treadmill where aerosol products are used or where oxygen is being administered.
6. Do not operate the treadmill until it is properly assembled (see HOW TO SET UP THE TREADMILL on page 7).
7. Regularly inspect and tighten all parts of the treadmill.
8. Keep children under the age of 12 and pets away from the treadmill at all times.
9. The treadmill should not be used by persons weighing more than 350 pounds.
10. Never allow more than one person on the treadmill at a time.
11. Wear appropriate exercise clothes when using the treadmill. Do not wear loose clothes that could become caught in the treadmill. Athletic support clothes are recommended for both men and women. *Always wear athletic shoes. Never use the treadmill with bare feet, wearing only stockings, or in sandals.*
12. When connecting the power cord (see page 10), plug the power cord into a grounded circuit capable of carrying 20 or more amps. No other appliance should be on the same circuit.
13. Do not use an extension cord. Do not modify the power cord or use an adaptor to connect the power cord to an improper receptacle.
14. Keep the power cord away from heated surfaces.
15. Never move the walking belt while the power is turned off. Do not operate the treadmill if the power cord or plug is damaged or if the treadmill is not working properly. (See BEFORE YOU BEGIN on page 6 if the treadmill is not working properly.)
16. Never start the treadmill while you are standing on the walking belt. Always hold the handrails while using the treadmill.
17. The treadmill is capable of high speeds. Adjust the speed in small increments to avoid sudden jumps in speed.
18. The pulse sensor is not a medical device. Various factors, including the user's movement, may affect the accuracy of heart rate readings. The pulse sensor is intended only as an exercise aid in determining heart rate trends in general.
19. Never leave the treadmill unattended while it is running. Always remove the key, unplug the power cord, and switch the on/off circuit breaker to the off position when the treadmill is not in use.
20. Do not change the incline of the treadmill by placing objects under it.
21. When using iFIT.com CDs, you will be alerted by an electronic "chirping" sound when the speed and/or incline of the treadmill is about to change. Always listen for the "chirp" and be prepared for speed and/or incline changes. In some instances, the speed and/or incline may change before the personal trainer describes the change.

22. When using iFIT.com CDs, you can manually override the speed and incline settings at any time by pressing the SPEED and INCLINE buttons. However, when the next “chirp” is heard, the speed and/or incline will change to the next settings of the CD program.

23. Always remove iFIT.com CDs from your CD player when you are not using them.

24. Never insert or drop any object into any opening.

25. Make sure to perform all maintenance procedures outlined in this manual. Failure to do so will void the warranty and may result in damage to the treadmill.

26. **DANGER:** Always unplug the power cord immediately after use, before cleaning the treadmill, and before performing the maintenance and adjustment procedures described in this manual. Servicing other than the procedures in this manual should be performed by an authorized service representative only.

⚠ WARNING: Before beginning this or any exercise program, consult your physician. This is especially important for persons over the age of 35 or persons with pre-existing health problems. Read all instructions before using. ICON assumes no responsibility for personal injury or property damage sustained by or through the use of this product.

SAVE THESE INSTRUCTIONS

WARNING DECAL PLACEMENT

The decals shown below are found on the treadmill. If any decal is missing or illegible, please call Customer Care toll-free at 1-800-201-2109, Monday through Friday, 8 a.m. until 5 p.m. Mountain Time (excluding holidays) to order a free replacement decal. Apply the decal in the location shown.

⚠ WARNING: HIGH VOLTAGE!
Please do not attempt to service this unit without contacting NordicTrack Commercial Fitness Division Customer Care at (800) 201-2109

	⚠ WARNING
	HAZARDOUS VOLTAGE Disconnect power before servicing.

Note: This decal is shown at 85% of actual size.

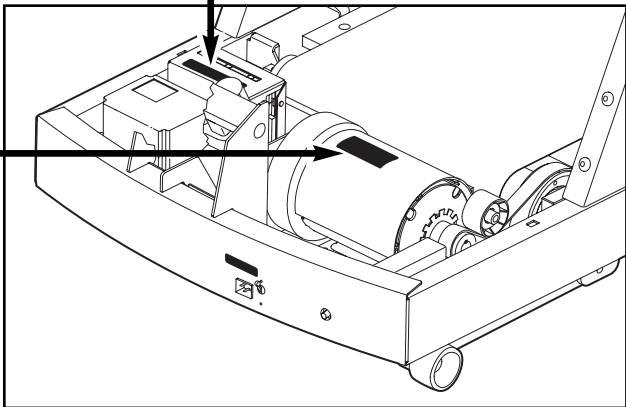

⚠ WARNING
Do not remove or insert this plug while the safety key is inserted in the console. Touch metal frame before removing or inserting plug. Static sensitive components may be affected.

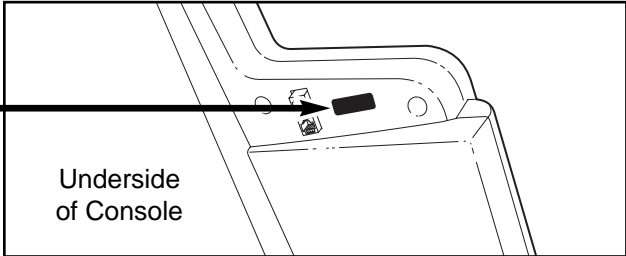

⚠ CAUTION: HIGH VOLTAGE
Disconnect line cord from outlet before servicing.

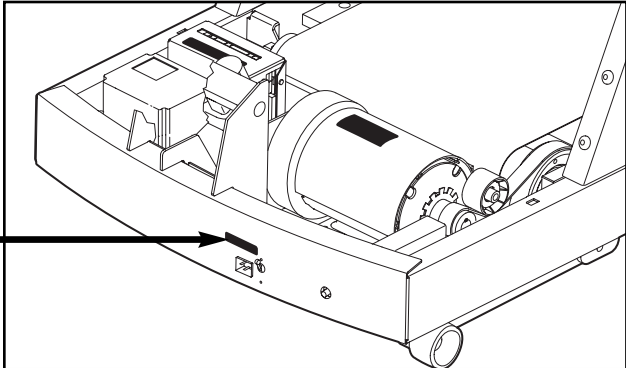

BEFORE YOU BEGIN

Congratulations for selecting the revolutionary NordicTrack® 9600 treadmill. The NordicTrack 9600 treadmill offers an impressive array of features to make your workouts more effective and enjoyable.

For your benefit, read this manual carefully before using the NordicTrack 9600 treadmill. If you have questions after reading this manual, please call Customer Care toll-free at 1-800-201-2109, Monday through Friday, 8 a.m. until 5 p.m. Mountain Time

(excluding holidays). To help us assist you, please note your product model number and serial number before calling. The model number of your treadmill is CTL82520 or CTL85020. The serial number can be found on a decal attached to the treadmill (see the front cover of this manual for the location of the decal).

Before reading further, please familiarize yourself with the parts that are labeled in the drawing below.

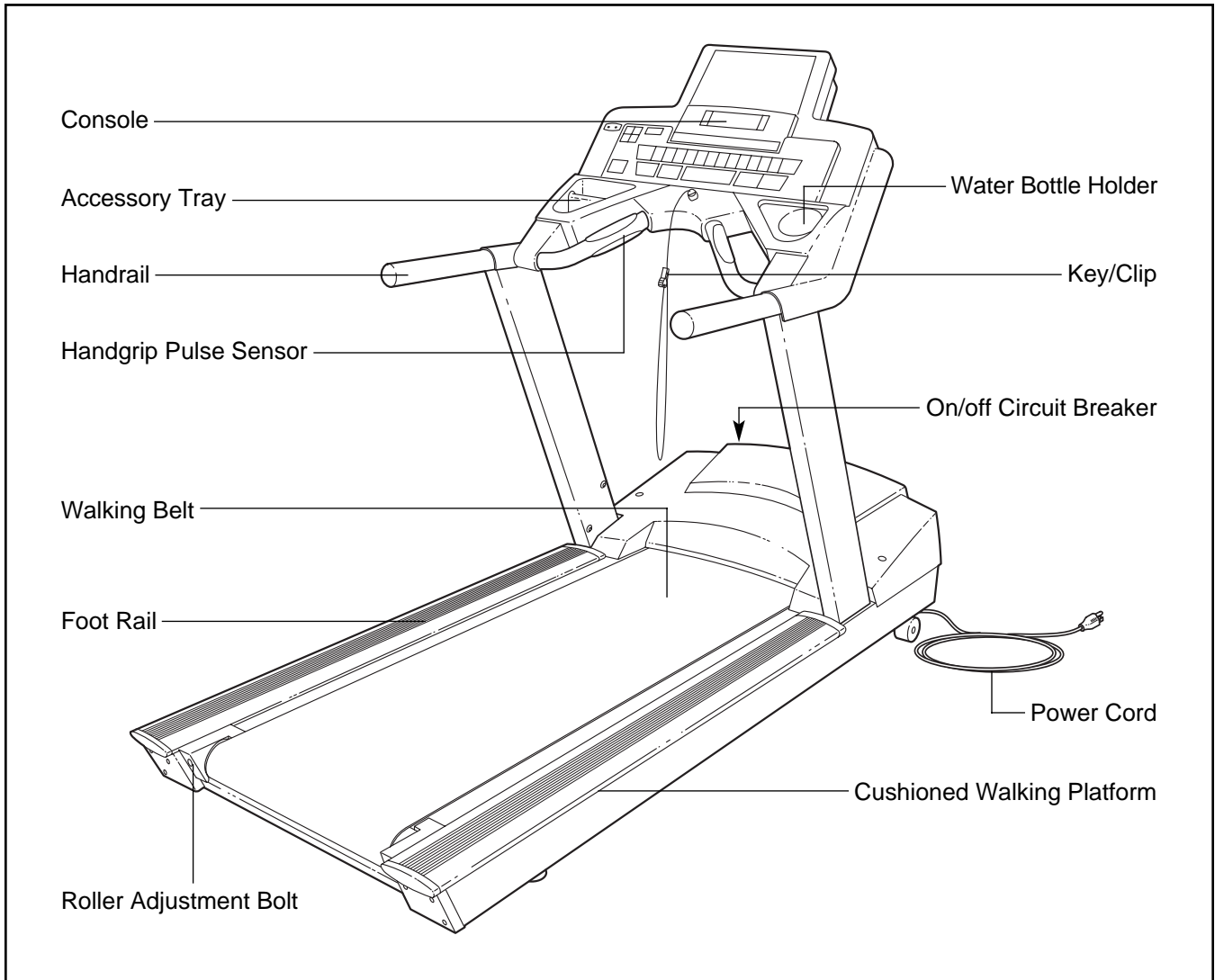

HOW TO SET UP THE TREADMILL

Assembly requires two persons. Set the treadmill in a cleared area and remove all packing materials. Do not dispose of the packing materials until assembly is completed. **Assembly can be completed using the included allen wrenches.**

Note: The underside of the treadmill walking belt is coated with high-performance lubricant. During shipping, a small amount of lubricant may be transferred to the top of the walking belt or the shipping carton. This is a normal condition and does not affect treadmill performance. If there is lubricant on top of the walking belt, simply wipe off the lubricant with a soft cloth and a mild, non-abrasive cleaner.

1. Slide the Right and Left Uprights (95, 97) onto the brackets near the front of the Frame (76). **Make sure that the Uprights are on the correct sides; the indicated holes must be facing the treadmill.**

Raise the Right Upright (95) until the lower hole in the front of the Upright is aligned with the upper hole in the bracket. Thread an Upright Bolt (96) into the Upright and the bracket. **Do not fully tighten the Upright Bolt yet.**

Repeat this step with the Left Upright (97).

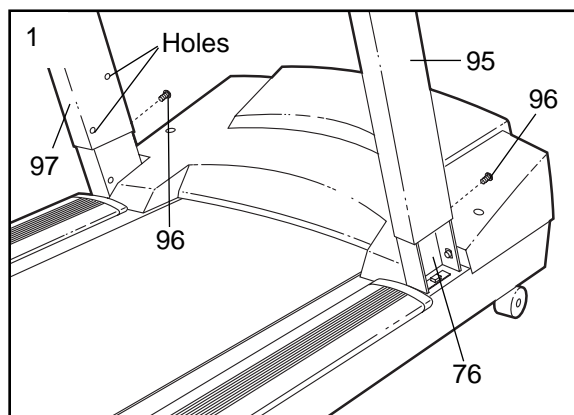

2. While a second person holds the Handrail (91) near the Uprights (95, 97), feed the wires in both sides of the Handrail down into the Uprights. Pull the ends of the wires out of the lower ends of the Uprights. If there are wire ties on the ends of the wires, remove them.

Finger tighten eight Handrail Bolts (99) into the Uprights (95, 97) and the Handrail (91). **Do not tighten the Handrail Bolts yet. Be careful to avoid pinching the wires.**

Note: The CD Holder (86) and the Cup Holder (85) are replaceable. If these parts become dislodged from the Console Base (89), simply press them back into place.

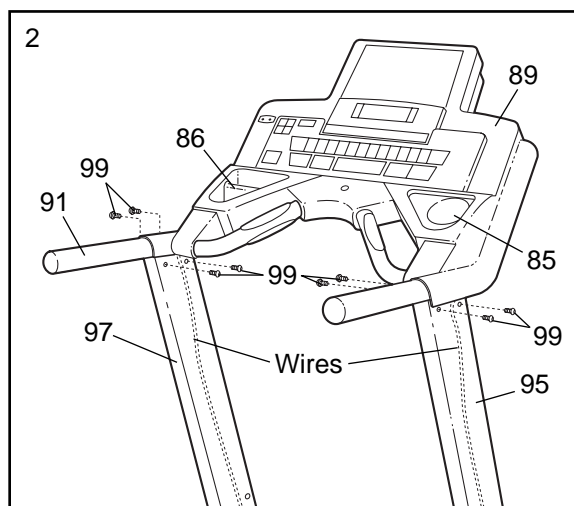

3. Connect the TV Cable (17) and the Right Power Wire Harness (57) in the indicated locations. Push all of the excess wire up into the Uprights (95, 97). **Make sure that all wires are fully connected. Note: Regardless of which console your treadmill has, connect all wires so that the console can later be upgraded if desired.**

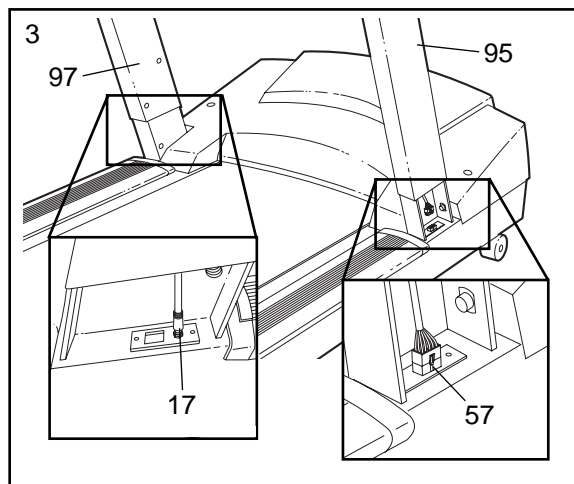

4. Refer to step 1. While a second person holds the Uprights (95, 97), remove the two Upright Bolts (96).

Slide the Uprights (95, 97) fully onto the brackets on the Frame (not shown). **Be careful to avoid pinching your hands or the wires.** Attach each Upright with four Upright Bolts (96) as shown. **Firmly tighten all eight Upright Bolts.**

Firmly tighten the eight Handrail Bolts (99).

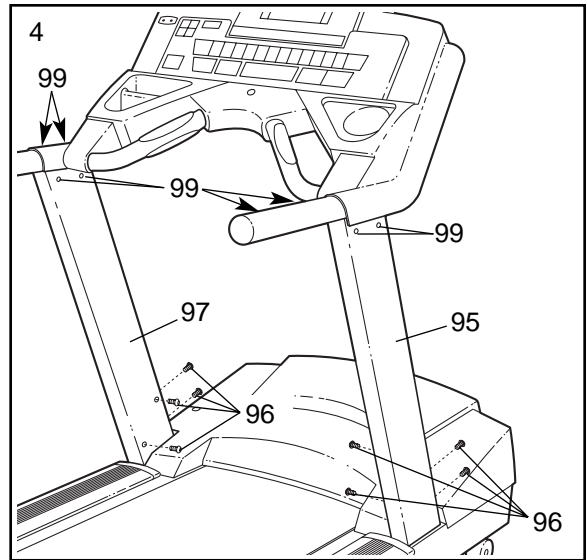

5. After the treadmill is placed in the location where it will be used (see HOW TO MOVE THE TREADMILL on page 9), make sure that both Rear Feet (5) and both front Wheels (not shown) rest firmly on the floor. If the treadmill rocks even slightly, turn the right Rear Foot clockwise or counterclockwise until the rocking motion is eliminated.

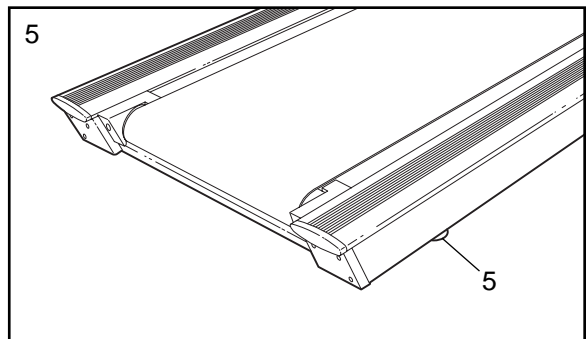

6. **Make sure that all parts are properly tightened before you use the treadmill.** Keep the included allen wrenches for adjustment purposes. To protect the floor or carpet from damage, place a mat under the treadmill.

HOW TO MOVE THE TREADMILL

Before moving the treadmill, make sure that the power cord is unplugged. Note: It may be necessary to disconnect the CATV cable from the treadmill, depending on how far the treadmill will be moved.

Due to the size and weight of the treadmill, moving it requires two persons. While one person lifts the indicated end, firmly hold the handrails and tip the treadmill forward until it rolls on the front wheels. Carefully move the treadmill to the desired location and then lower it back to the level position. Note: It may be helpful to change the incline of the treadmill to 5% before moving the treadmill. **CAUTION: To reduce the risk of injury, use extreme caution while moving the treadmill. Do not attempt to move the treadmill over uneven surfaces.**

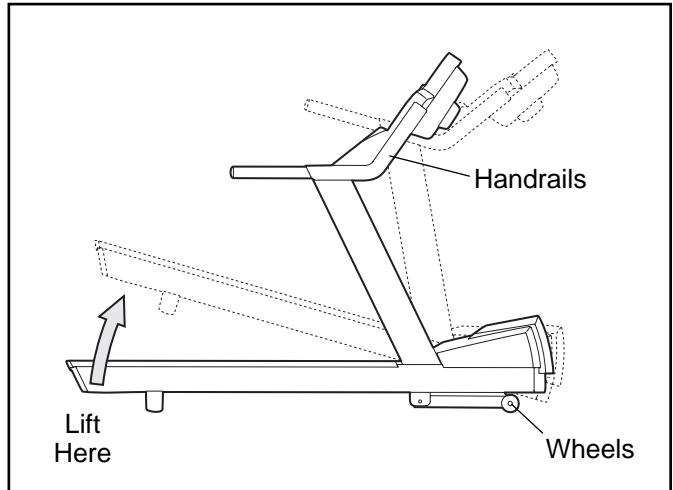

HOW TO CONNECT THE TREADMILL

HOW TO CONNECT THE POWER CORD

This product must be grounded. If it should malfunction or break down, grounding provides a path of least resistance for electric current to reduce the risk of electric shock.

⚠ DANGER: Improper connection of the equipment-grounding conductor can result in an increased risk of electric shock. Check with a qualified electrician or serviceman if you are in doubt as to whether the product is properly grounded. Do not modify the plug provided with the product—if it will not fit the outlet, have a proper outlet installed by a qualified electrician. Do not use an adapter to connect the plug to an improper receptacle.

This product is for use on a dedicated, 20-amp, 120-volt circuit. No other appliance should be on the same circuit. This product is equipped with a cord having an equipment-grounding

conductor and a grounding plug. Plug one end of the cord into the treadmill as shown in drawing 1. Attach the cord bracket over the cord with two bracket screws.

Plug the grounding plug into a standard NEMA 5-20 receptacle as shown in drawing 2. Do not modify the plug or the receptacle. Do not use an adapter, a surge protector, or an extension cord.

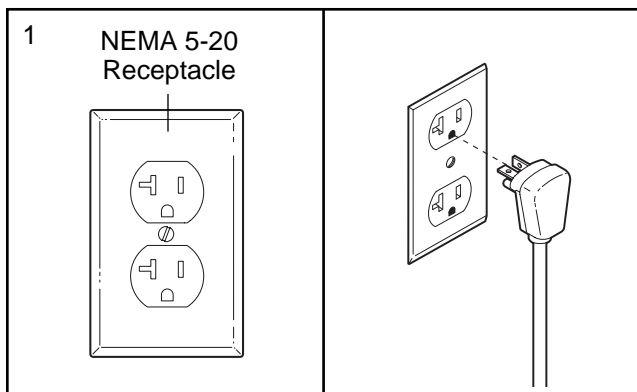
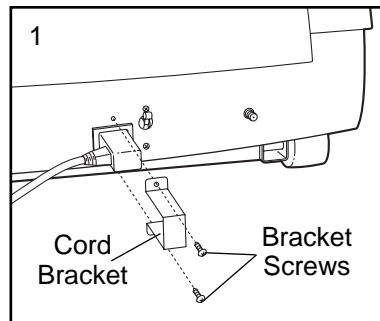

HOW TO CONNECT A CATV CABLE

If your treadmill has the Workout TV console, a CATV cable must be connected to the treadmill for cable TV stations to be viewed.

Locate the cable jack on the front of the treadmill. Connect the CATV cable to the cable jack. Route the cable so that it will not be pinched or crushed by the wheels when the incline is changed.

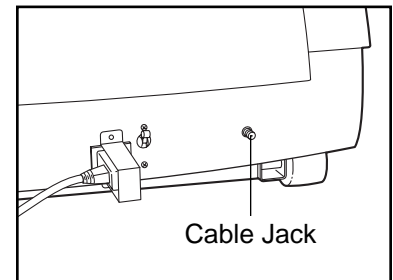

A satellite receiver, VCR, or DVD player can also be connected to the treadmill. Connect a CATV cable from the coaxial output on your equipment (usually labeled TV OUT or RF OUT) to the cable jack on the front of the treadmill.

Note: Audio/video equipment without coaxial outputs (some satellite receivers and DVD players) will require an RF modulator to work correctly with the treadmill. RF modulators are not available from FreeMotion Fitness, but are available at electronics stores. See the owner's manual for the equipment you wish to connect to determine if an RF modulator is needed.

HOW TO CONNECT YOUR CD PLAYER TO THE TREADMILL

With the **Basic console** or the **Workout TV console**, you can connect a portable CD player to the treadmill and use iFIT.com CDs. (Refer to page 22 for instructions about using iFIT.com CDs.)

HOW TO CONNECT YOUR PORTABLE CD PLAYER

Plug one end of the included male-to-male audio cable into the jack on the left side of the console. Plug the other end of the audio cable into the PHONES jack on your CD player. Plug your headphones into the jack on the console.

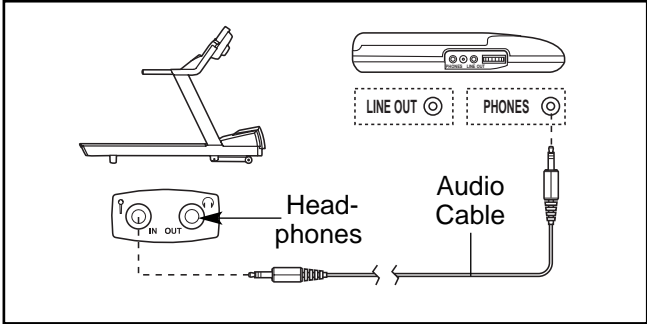

HOW TO UPGRADE YOUR CONSOLE

Your treadmill has been pre-configured to operate with the Basic console and the Workout TV console (see the drawings below).

For information about the features of the Basic console, refer to page 13. To learn about the state-of-the-art Workout TV console, refer to page 26.

To upgrade your console and expand the capabilities of your treadmill whenever you choose, simply contact your local FreeMotion Fitness Sales Representative or call FreeMotion Fitness toll-free at 1-877-363-8449.

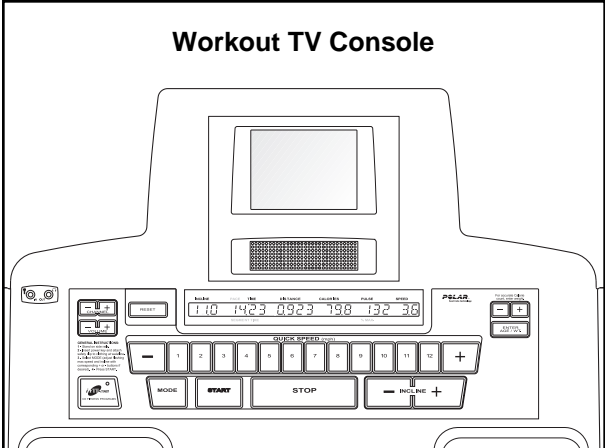
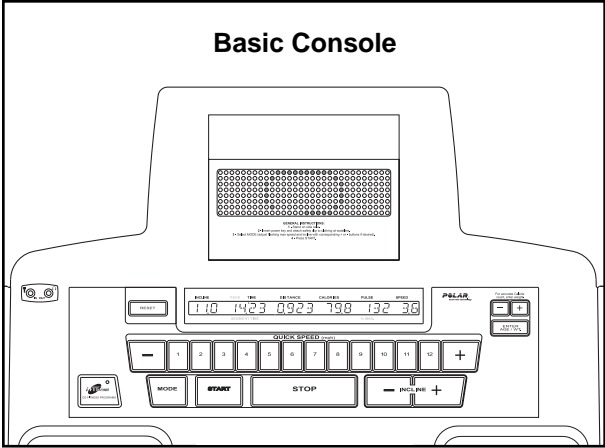

HOW TO USE THE BASIC CONSOLE

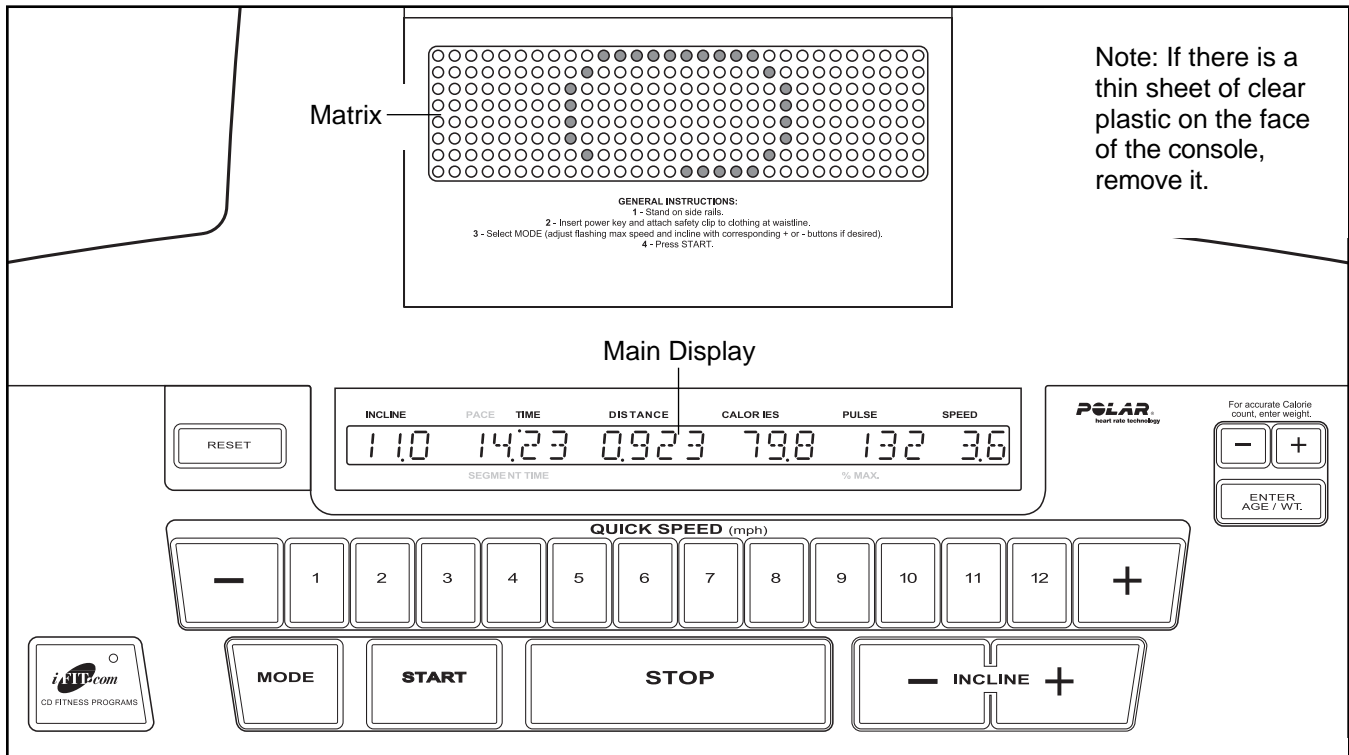

FEATURES OF THE CONSOLE

The Basic console offers an impressive array of features to help you get the most from your exercise.

When the manual mode of the console is selected, the speed and incline of the treadmill can be changed with a touch of a button. As you exercise, the console will provide continuous exercise feedback. You can even measure your heart rate using the built-in pulse sensor.

Six preset workout programs are also offered. Each program automatically controls the speed and incline of the treadmill to give you an effective workout.

In addition, the console offers three pulse-driven programs that adjust the speed and incline of the treadmill to keep your heart rate near target levels during your

workouts, and a unique fitness test program that measures your relative fitness level. Note: The pulse-driven programs and the fitness test program require the use of a Polar®-compatible chest pulse sensor (not included).

The console also features new iFIT.com interactive technology. iFIT.com technology is like having a personal trainer right at your side. Using the included audio cable, you can connect your portable CD player to the treadmill and play special iFIT.com CD programs (CDs are available separately). iFIT.com CD programs automatically control the speed and incline of the treadmill as a personal trainer guides you through every step of your workout. High-energy music provides added motivation. Each CD features two programs designed by certified personal trainers. **To order iFIT.com CDs, call toll-free 1-877-363-8449.**

⚠ CAUTION: Before operating the console, read the following precautions.

- Do not stand on the walking belt when turning on the power.
- Always wear the clip (see the drawing at the right) while operating the treadmill.
- Adjust the speed in small increments to avoid sudden jumps in speed.
- The pulse sensor is not a medical device. Various factors may affect the accuracy of heart rate readings. The pulse sensor is intended only as an exercise aid in determining heart rate trends in general.
- If you have heart problems, or if you are over 60 years of age and have been inactive, do not use the pulse-driven programs. If you are taking medication regularly, consult your physician to find whether the medication will affect your exercise heart rate.
- To reduce the possibility of electric shock, keep the console dry. Avoid spilling liquids on the console and place only a sealed water bottle in the water bottle holder. Do not spray cleaners directly onto the console.

GETTING STARTED

1 Plug in the power cord.

Refer to HOW TO CONNECT THE POWER CORD on page 10.

2 Move the on/off circuit breaker to the on position.

Locate the on/off circuit breaker on the treadmill near the power cord. Switch the on/off circuit breaker to the on position.

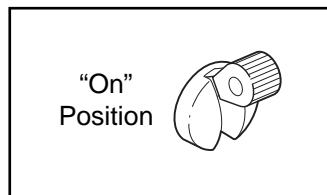

3 Insert the key into the console.

Note: The console can be set to be used without the key. Refer to step 11 on page 24 for instructions. **If the console has been set to be used without the key, go to step 4.**

Find the key and the clip on the console and attach the clip to the waistband of your clothes.

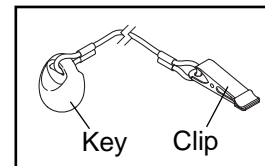

Next, insert the key into the console.

Test the clip by carefully taking a few steps backward until the key is pulled from the console. If the key is not pulled from the console, adjust the position as needed.

Insert the key into the console again. After a moment, various displays and indicators on the console will light.

4 Enter your weight.

Although you can use the console without entering your weight, if you enter your weight the console will more accurately count the Calories that you burn. To enter your weight, first press the ENTER AGE/WT button. The words ENTER WEIGHT and the current weight setting will appear in the main display.

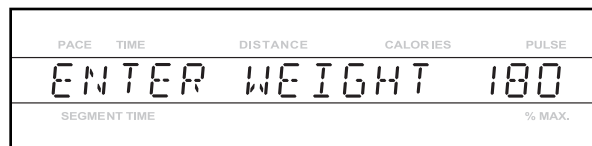

Press the + and – buttons above the ENTER AGE/WT button to enter your weight. The buttons can be held down to enter your weight quickly.

To use the manual mode of the console, follow the steps beginning on page 15. **To use a preset program,** refer to page 17. **To use a pulse-driven program,** refer to page 19. **To use the fitness test program,** refer to page 20. **To use an iFIT.com CD program,** refer to page 22. **To use the maintenance mode,** refer to page 23.

HOW TO USE THE MANUAL MODE

1 Insert the key into the console.

Refer to GETTING STARTED on page 14.

2 Select the manual mode.

When the key is inserted, the manual mode will automatically be selected. If a program or the iFIT.com mode has been selected, press the MODE button repeatedly until the main display appears as shown below.

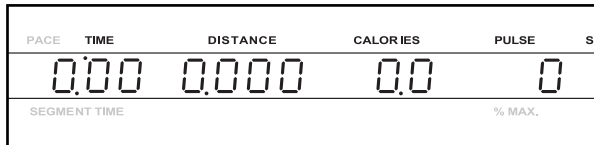

3 Press the START button or the SPEED + button to start the walking belt.

A moment after the button is pressed, the walking belt will begin to move at 1 mph. Hold the handrails and begin walking.

As you exercise, change the speed of the walking belt as desired by pressing the SPEED + and – buttons. Each time a button is pressed, the speed setting will change by 0.1 mph; if a button is held down, the speed setting will change in increments of 0.5 mph. To change the speed quickly, press the QUICK SPEED buttons. The speed range is 0.5 mph to 12 mph. Note: After the buttons are pressed, it may take a moment for the treadmill to reach the selected speed setting.

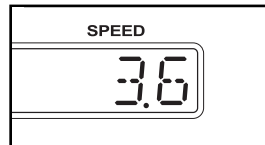

To stop the walking belt, press the STOP button. The time will begin to flash in the main display. To restart the walking belt, press the START button or the SPEED + button and then adjust the speed as desired.

4 Change the incline of the treadmill as desired.

To change the incline of the treadmill, press the INCLINE + and – buttons. Each time a button is pressed, the in-

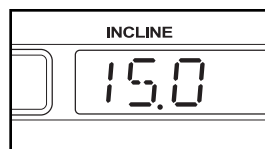

cline will change by 0.5%. The incline range is 0% to 15%. Note: After the buttons are pressed, it may take a moment for the treadmill to reach the selected incline setting.

5 Follow your progress with the matrix and the main display.

The matrix—When the manual mode or the iFIT.com mode is selected, the matrix will display a 1/4-mile track. As you exercise, the indicators around the track will light in sequence to show your position on the track. Each time you complete a 1/4-mile lap, a new lap will begin.

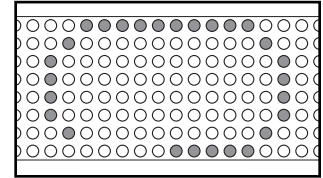

The main display—The main display will show the following information:

Incline—The left end of the main display will show the incline level of the treadmill.

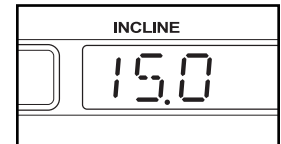

Pace/Time—When the manual mode or the iFIT.com mode is selected, this section of the main display will show the elapsed time. When a preset program or a pulse-driven program is selected, the display will show the time remaining in the program and the time remaining in the current segment of the program. The display will change from one number to the other every seven seconds. During the fitness test program, the display will show the elapsed time and the time remaining in the current segment of the program. Note: Any time that the speed setting changes, the display will show your current pace (in *minutes per mile*) for seven seconds.



Distance—The center section of the main display will show the distance that you have walked or run.

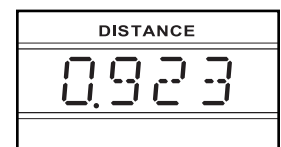

Calories—This section of the main display will show the approximate number of Calories you have burned.

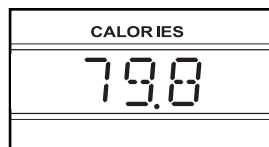

Pulse/% Max—When you are using the handgrip pulse sensor or a Polar®-compatible chest pulse sensor (not included), this section of the main display will show your heart rate (refer to step 6). When a pulse-driven program is selected, the display will show your heart rate and the *corresponding percentage* of your *estimated maximum heart rate*. (Refer to step 5 on page 19 for an explanation of your estimated maximum heart rate.) The display will change from one number to the other every seven seconds.

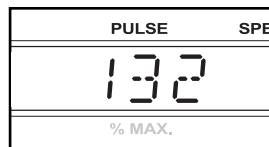

Speed—The right end of the main display will show the speed of the walking belt.

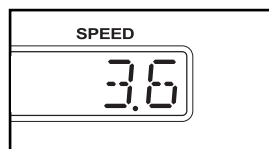

To reset the displayed time, distance, and Calories at any time, press the RESET button.

6 Measure your heart rate if desired.

To measure your heart rate, **stand on the foot rails** and hold the handgrip pulse sensor with both hands. Your palms must be resting on the upper contacts and your fingers must be touching the lower contacts—

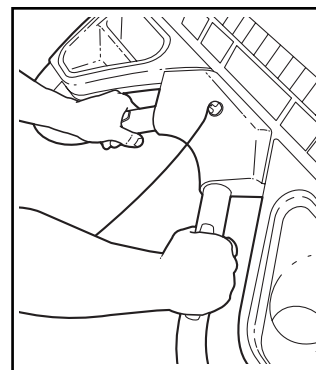

avoid moving your hands. When your pulse is detected, the words ACQUIRING PULSE will appear in the main display and then your heart rate will be shown. **For the most accurate heart rate reading, continue to hold the contacts for at least 15 seconds.**

7 When you are finished exercising, stop the walking belt and remove the key.

Step onto the foot rails and press the STOP button. Next, remove the key from the console and put the key in a secure place.

When the treadmill is not in use, switch the on/off circuit breaker near the power cord to the off position and unplug the power cord.

HOW TO USE PRESET PROGRAMS

1 Insert the key into the console.

Refer to GETTING STARTED on page 14.

2 Select one of the six preset programs.

When the key is inserted, the manual mode will automatically be selected. To select one of the six preset programs, press the MODE button repeatedly until the words CARDIO WALK 1, CARDIO WALK 2, ENDURANCE 1, ENDURANCE 2, FINISH LINE 1, or FINISH LINE 2 appear in the main display. Note: CARDIO WALK 1 is a level one (low-intensity) walking program; CARDIO WALK 2 is a level one running program; ENDURANCE 1 is a level two (medium-intensity) walking program; ENDURANCE 2 is a level two running program; FINISH LINE 1 is a level three (high-intensity) walking program; and FINISH LINE 2 is a level three running program.



When a preset program is selected, the maximum incline setting for the program will flash at the left end of the main display and the maximum speed setting will flash at the right end of the main display. After three seconds, the name of the selected program, the level of the program, and the total program time will begin to scroll across the main display. If desired, you can change the maximum incline setting or the maximum speed setting by pressing the INCLINE or SPEED buttons. If you increase either setting, the difficulty level of the entire program will increase; if you decrease either setting, the difficulty level of the entire program will decrease.

When a preset program is selected, the matrix will show a graph representing the speed settings for the program.

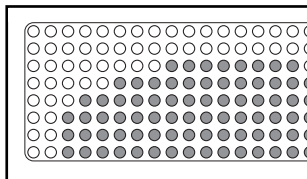

3 Press the START button or the SPEED + button to start the program.

A moment after the button is pressed, the treadmill will automatically adjust to the first speed and incline settings for the program. Hold the handrails and begin walking.

Each program is divided into several time segments of different lengths. The main display will show both the time remaining in the program and the time remaining in the current segment of the program. One speed setting and one incline setting are programmed for each segment. The speed setting for the first segment is shown in the flashing CUR-

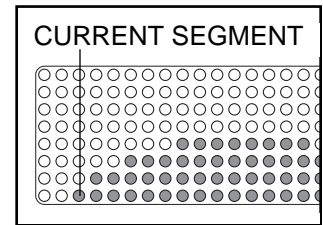

RURRENT SEGMENT

column of the matrix. (The incline settings are not shown in the matrix.) The speed settings for upcoming segments are shown in the columns to the right.

When only three seconds remain in the first segment of the program, both the CURRENT SEGMENT column and the column to the right will flash, a series of tones will sound, and *all speed settings will move one column to the left*. The speed setting for the second segment will then be shown in the CURRENT SEGMENT column and the treadmill will automatically adjust to the speed and incline settings for the second segment. The program will continue until the speed setting for the final segment is shown in the CURRENT SEGMENT column and no time remains in the program. The walking belt will then slow to a stop.

Note: Each time a segment ends and the speed settings move to the left, *if all of the indicators in the CURRENT SEGMENT column are lit, the speed settings may move downward so that only the highest indicators in the columns appear in the matrix*. When the speed settings move to the left again, if not all of the indicators in the CURRENT SEGMENT column are lit, the speed settings will move back up.

Note: You can manually override the speed or incline setting for the current segment by pressing the SPEED or INCLINE buttons. Every few times a SPEED button is pressed, an additional indicator will light or darken in the CURRENT SEGMENT column. (If any of the columns to the right of the CURRENT SEGMENT column have the same number of lit indicators as the CURRENT SEGMENT column, an additional indicator may light or darken in those columns as well.) **Important:** **When the next segment of the program begins, the treadmill will automatically adjust to the speed and incline settings for the next segment.**

To stop the program, press the STOP button. The time will begin to flash in the main display. To restart the program, press the START button or the SPEED + button. The walking belt will begin to move at 1 mph. When the next segment of the program begins, the treadmill will automatically adjust to the speed and incline settings for the next segment.

4 Follow your progress with the main display.

Refer to step 5 on page 15.

5 Measure your heart rate if desired.

Refer to step 6 on page 16.

6 When the program is completed, remove the key.

Step onto the foot rails. Remove the key from the console and put the key in a secure place.

When the treadmill is not in use, switch the on/off circuit breaker near the power cord to the off position and unplug the power cord.

HOW TO USE PULSE-DRIVEN PROGRAMS

Pulse-driven programs automatically control the speed and incline of the treadmill to keep your heart rate near a target level while you exercise. Follow the steps below to use a pulse-driven program.

1 Put on a Polar®-compatible chest pulse sensor (not included).

You must wear a chest pulse sensor to use a pulse-driven program. Refer to the instructions included with your chest pulse sensor.

2 Insert the key into the console.

Refer to GETTING STARTED on page 14.

3 Select one of the three pulse-driven programs.

When the key is inserted, the manual mode will be selected. To select one of the three pulse-driven programs, press the MODE button repeatedly until the words **CARDIO WALK PULSE**, **ENDURANCE PULSE**, or **MANUAL PULSE** appear in the main display. Note: The **CARDIO WALK PULSE** program will keep your heart rate near 65% of your *estimated maximum heart rate* (refer to step 5 at the right for an explanation of your estimated maximum heart rate). The **ENDURANCE PULSE** program will keep your heart rate near 80% of your estimated maximum heart rate. The **MANUAL PULSE** program will keep your heart rate near a percentage that you select.



When a pulse-driven program is selected, the name of the selected program and the total program time will scroll across the main display. The words **ENTER AGE** and the current age setting will then be shown.

During pulse-driven programs, the matrix will show a moving graphic that represents your heart rate. Each time a heart-beat is detected, an additional peak will appear in the graphic.

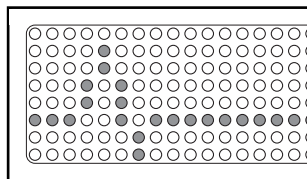

4 Enter your age.

You must enter your age to use a pulse-driven program. To enter your age, press the + and – buttons above the **ENTER AGE/WT** button. The buttons can be held down to enter your age quickly. The age range is 20 to 80 years. When your age is shown, press the **ENTER AGE/WT** button.



If you have selected the **CARDIO WALK PULSE** or **ENDURANCE PULSE** program, go to step 6. If you have selected the **MANUAL PULSE** program, go to step 5.

5 Enter a target heart rate setting.

After you have entered your age, the words **ENTER PERCENT** and the target heart rate setting for the program will be shown in the main display. The target heart rate setting represents a *percentage* of your *estimated maximum heart rate*. Your estimated maximum heart rate is 220 minus your age. For example, if you are 30 years old, your estimated maximum heart rate is 190 beats per minute ($220 - 30 = 190$). If you are 30 years old, a target heart rate setting of 50 is equal to 95 beats per minute (50% of 190 is 95).

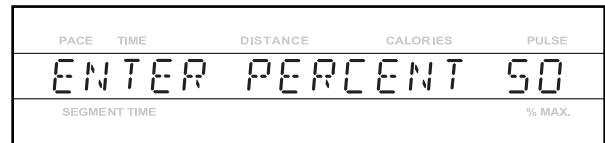

If desired, you can change the target heart rate setting by pressing the + and – buttons above the **ENTER AGE/WT** button. The buttons can be held down to change the target heart rate setting quickly. The target heart rate setting can be from 50% to 85% of your estimated maximum heart rate.

6 Press the **START** button or the **SPEED +** button to start the program.

A moment after the button is pressed, the treadmill will automatically adjust to the first speed and incline settings for the program. Hold the handrails and begin walking.

Each pulse-driven program is divided into one-minute segments. (The main display will show both the time remaining in the program and the time remaining in the current segment of the program.) One target heart rate setting is programmed for each segment. (During the MANUAL PULSE program, the same target heart rate setting will be programmed for all segments.)

When only three seconds remain in the first segment of the program, a series of tones will sound and then the speed and/or incline of the treadmill will change, if needed, to bring your heart rate closer to the target heart rate setting for the next segment. The speed and/or incline setting will flash in the main display to alert you before the speed and/or incline changes. The program will continue until no time remains in the program. The walking belt will then slow to a stop.

If the speed and incline setting for the current segment is too high or too low, you can adjust the setting with the SPEED or INCLINE buttons. However, if you *decrease* the speed, the incline will automatically *increase*; if you *increase* the speed, the incline will *decrease*. If you *increase* the incline, the speed will *decrease*; if you *decrease* the incline, the speed will *increase*. *The treadmill will always attempt to keep your heart rate near the target heart rate setting for the current segment.* Note: When the incline reaches the lowest setting, the speed cannot be increased any further. When the incline reaches the highest setting, the speed cannot be decreased any further.

If your pulse is not detected during the program, the letters PLS will flash in the main display and the speed and incline of the treadmill may automatically decrease until your pulse is detected. If this occurs, refer to the instructions included with your chest pulse sensor.

To stop the program at any time, press the STOP button. Pulse-driven programs should not be stopped temporarily and then restarted. To use a pulse-driven program again, reselect the program and start it at the beginning.

7 Follow your progress with the main display.
Refer to step 5 on page 15.

8 When the program is completed, remove the key.
Refer to step 6 on page 18.

HOW TO USE THE FITNESS TEST PROGRAM

The fitness test program measures your relative fitness level. For the best results, the program should be used at a time when your energy level is high; the program should not be used if you have already exercised during the day. Follow the steps below to use the program.

1 Put on a Polar®-compatible chest pulse sensor (not included).

You must wear a chest pulse sensor to use the fitness test program.

2 Insert the key into the console.

Refer to GETTING STARTED on page 14.

3 Select the fitness test program.

When the key is inserted, the manual mode will be selected. To select the fitness test program, press the MODE button repeatedly until the words FITNESS TEST appear in the main display.

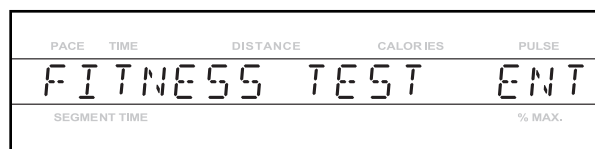

When the fitness test program is selected, the words FITNESS TEST will scroll across the main display. The words ENTER AGE and the current age setting will then be shown.

During the fitness test program, the matrix will show a moving graphic that represents your heart rate.

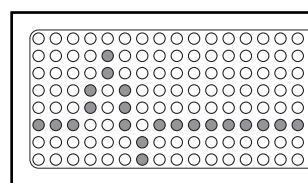

Each time a heart-beat is detected, an additional peak will appear in the graphic.

4 Enter your age.

Your must enter your age to use the fitness test program. To enter your age, refer to step 4 on page 19.



5 Press the **START** button or the **SPEED +** button to start the program.

When the button is pressed, the main display will show the words LEVEL 1, indicating that the first four-minute level of the fitness test program has begun. The incline of the treadmill will then automatically adjust to 3% and the walking belt will begin to move at 1.5 mph. Hold the handrails and begin walking.

PACE	TIME	DISTANCE	CALORIES	PULSE	SEGMENT TIME	% MAX.
0.35		LEVEL 1		118		

The fitness test program is divided into seven, four-minute levels. One speed setting and one incline setting are programmed for each level. At the end of each minute of the program, a tone will sound; when the first four-minute level is completed, a tone will sound and the main display will show the words LEVEL 2, indicating that the second four-minute level has begun. The incline will then change to 4% and the speed of the walking belt will increase to 2.5 mph.

At the beginning of each four-minute level, the speed and/or incline of the treadmill will automatically increase. The fitness test program will continue in this way until your heart rate reaches 70% of your estimated maximum heart rate and the current four-minute level is completed. *The fitness test program will then end, regardless of how many levels remain.*

When the fitness test program is completed, the words COOL-DOWN will be shown in the main

display and a two-minute cool-down period will begin. The speed and incline will then decrease.

PACE	TIME	DISTANCE	CALORIES	PULSE	SEGMENT TIME	% MAX.
1.49		COOL DOWN		118		

When the cool-down period is completed, the walking belt will slow to a stop and your fitness level will be shown in the main display. There are ten fitness levels; fitness level 10 is the highest.

PACE	TIME	DISTANCE	CALORIES	PULSE	SEGMENT TIME	% MAX.
		FIT LEVEL 06				

Note: The SPEED and INCLINE buttons will not function while the fitness test program is selected. If your pulse is not detected during the program, the letters PLS will flash in the main display. If your pulse is not detected at the end of any four-minute level, the fitness test program will end and the main display will show a fitness level of 0.

The fitness test program cannot be stopped temporarily and then restarted. However, the program can be stopped at any time with the STOP button. The main display will then show an estimated fitness level.

6 When the program is completed, remove the key.

Refer to step 6 on page 18.

HOW TO USE iFIT.COM CD PROGRAMS

To use iFIT.com CDs, your portable CD player must be connected to the treadmill. See HOW TO CONNECT YOUR CD PLAYER TO THE TREADMILL on page 11.

Follow the steps below to use an iFIT.com CD program.

1 Insert the key into the console.

Refer to GETTING STARTED on page 14.

2 Select the iFIT.com mode.

When the key is inserted, the manual mode will be selected. To select the iFIT.com mode, press the iFIT.COM button. The indicator on the button will light.



3 Insert an iFIT.com CD.

Insert the iFIT.com CD into your CD player.

4 Press the PLAY button on your CD player.

A moment after the button is pressed, a recorded personal trainer will begin guiding you through your workout. Simply follow the personal trainer's instructions. Note: If the time is flashing in the main display, press the START button or the SPEED + button on the console. The treadmill will not respond to a CD program while the time is flashing.

During the CD program, an electronic "chirping" sound will alert you when the speed and/or incline of the treadmill is about to change. **CAUTION: Always listen for the "chirp" and be prepared for speed and/or incline changes. In some instances, the speed and/or incline may change before the personal trainer describes the change.**

If the speed or incline settings are too high or too low, you can manually override the settings at any

time by pressing the SPEED or INCLINE buttons on the console. However, **when the next "chirp" is heard, the speed and/or incline will change to the next settings of the CD program.**

To stop the walking belt at any time, press the STOP button on the console. The time will begin to flash in the main display. To restart the program, press the START button or the SPEED + button. After a moment, the walking belt will begin to move at 1 mph. **When the next "chirp" is heard, the speed and incline will change to the next settings of the CD program.** The program can also be stopped by pressing the STOP button on your CD player.

When the CD program is completed, the walking belt will stop and the time will begin to flash in the main display. Note: To use another CD program, press the STOP button or remove the key and go to step 1.

Note: If the speed or incline of the treadmill does not change when a "chirp" is heard:

- **Make sure that the iFIT.com indicator is lit and that the time is not flashing in the main display. If the time is flashing, press the START button or the SPEED + button on the console.**
- **Adjust the volume of your CD player. If the volume is too high or too low, the console may not detect the program signals.**
- **Make sure that the audio cable is properly connected, that it is fully plugged in, and that it is not wrapped around a power cord.**

5 Follow your progress with the main display.

Refer to step 5 on page 15.

6 Measure your heart rate, if desired.

Refer to step 6 on page 16.

7 When the program is completed, remove the key.

Refer to step 6 on page 18.

HOW TO USE THE MAINTENANCE MODE

The console features a maintenance mode that allows you to access information and to view and change various default settings. Follow the steps below to use the maintenance mode.

1 Insert the key into the console.

Refer to GETTING STARTED on page 14.

2 Hold down the ENTER AGE/WT button and the RESET button simultaneously for two seconds to select the maintenance mode.

When the maintenance mode is selected, the words MAINTENANCE MODE will appear in the main display.



3 Press the ENTER AGE/WT button to view the total number of hours that the treadmill has been used.



4 Press the ENTER AGE/WT button again to view the total distance that the walking belt has moved.



5 Press the ENTER AGE/WT button again and set the delay time for the timeout mode.

Any time that the treadmill is not used for several minutes, the console will enter a timeout mode and the words PUSH ANY BUTTON TO START A NEW PROGRAM will begin to scroll across the main display. To set the number of minutes before the console will enter the timeout mode, press the

+ and – buttons above the ENTER AGE/WT button. The delay time can be from 1 to 15 minutes.



6 Press the ENTER AGE/WT button again and set the program time for the CARDIO WALK 1, ENDURANCE 1, and FINISH LINE 1 programs.

The CARDIO WALK 1, ENDURANCE 1, and FINISH LINE 1 programs can be set to last for 20, 30, or 40 minutes. To change the setting, press the + and – buttons above the ENTER AGE/WT button.



7 Press the ENTER AGE/WT button again and set the program time for the CARDIO WALK 2, ENDURANCE 2, and FINISH LINE 2 programs.

The CARDIO WALK 2, ENDURANCE 2, and FINISH LINE 2 programs can be set to last for 20, 30, or 40 minutes. To change the setting, press the + and – buttons above the ENTER AGE/WT button.



8 Press the ENTER AGE/WT button again to check for controller errors.

If there are no controller errors, the words NO CONTROLLER ERRORS will appear in the main display. If there is a controller error, the name of the error will appear in the main display. If this occurs, press the RESET button. If the same controller error appears repeatedly, call Customer Care toll-free at 1-800-201-2109.

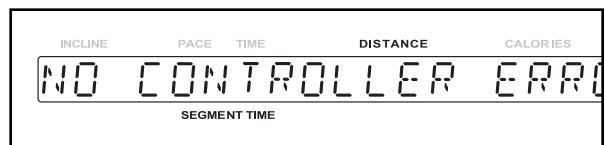

9 Press the ENTER AGE/WT button again to check for system errors.

If there are no system errors, the words NO SYSTEM ERRORS will appear in the main display. If the words LUBRICATE DECK appear in the main display, the walking platform should be checked for adequate lubricant. Follow the instructions in step 4 on page 29 to lubricate the walking platform if necessary. Then, refer to HOW TO RESET THE LUBE REMINDER on page 25.

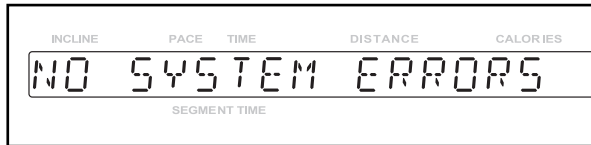

10 Press the ENTER AGE/WT button again and enable or disable the lubrication reminder.

The console can be set to display the words LUBRICATE DECK every 15 minutes when the walking platform needs to be lubricated. Press the + or – button above the ENTER AGE/WT button until the words LUBE REMINDER ENABLED appear in the main display. To turn off the lubrication reminder, press the + or – button until the words LUBE REMINDER DISABLED appear.



11 Press the ENTER AGE/WT button again and enable or disable the safety key.

To require the use of the safety key with the console, press the + or – button above the ENTER AGE/WT button until the words SAFETY KEY ENABLED appear in the main display. To allow the treadmill to be used without the key, press the + or – button until the words SAFETY KEY DISABLED appear. **CAUTION: If the safety key is missing or damaged, call Customer Care toll-free at 1-800-201-2109, Monday through Friday, 8 a.m. until 5 p.m. Mountain Time.**

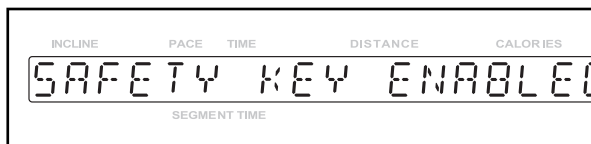

If you have the Basic console, go to step 16. If you have the Workout TV console, go to step 12.

12 Press the ENTER AGE/WT button again and enable or disable the TV.

To make the TV available for use, press the + or – button above the ENTER AGE/WT button until the words TV POWER ON appear in the main display. To prevent the TV from being used, press the + or – button until the words TV POWER OFF appear.

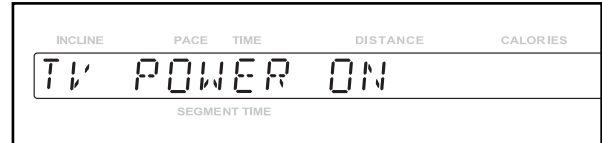

If you have disabled the TV, go to step 16. If you have enabled the TV, go to step 13.

13 Press the ENTER AGE/WT button again and select a cable TV connection or an antenna connection.

If you are using a cable TV connection, press the + or – button beside the ENTER AGE/WT button until the words TV MODE CABLE STATIONS appear in the main display. If you are using an antenna connection, press the + or – button until the words TV MODE AIR STATIONS appear.



14 Press the ENTER AGE/WT button again and program TV channels.

The console has the capability to find and store in memory all of the valid TV channels in your area. While the words PRESS CHANNEL UP TO SCAN TV CHANNELS are scrolling across the main display, press the CHANNEL + button to start the channel scanning process.



The console will begin scanning all TV channels. If no broadcast signal is detected on a channel, the channel will be skipped; if a signal is detected, a tone will sound and the channel will be stored in memory. This process will continue until the highest channel is reached. The lowest channel stored in memory will then appear in the main display.

15 Press the ENTER AGE/WT button again and delete or add TV channels.

After all valid TV channels have been stored in the console's memory, you can delete unwanted channels or add other channels. To delete or add a channel, first press the CHANNEL + and – buttons until the channel appears in the main display.



Next, press the + or – button above the ENTER AGE/WT button until the words DELETE or ADD appear in the main display. Then, select the next channel that you want to delete or add. Repeat this process until you have finished deleting or adding channels.

16 Hold down the ENTER AGE/WT button and the RESET button simultaneously for two seconds to exit the maintenance mode.

To exit the maintenance mode at any time, hold down the ENTER AGE/WT button and the RESET button simultaneously for two seconds.

HOW TO RESET THE LUBE REMINDER

If the words LUBRICATE DECK appear in the main display when the maintenance mode is selected (refer to step 9 on page 24), follow the steps below to reset the lube reminder.

1 Insert the key into the console.

Refer to GETTING STARTED on page 14.

2 Hold down the STOP button and the RESET button simultaneously for three seconds.

HOW TO USE THE WORKOUT TV CONSOLE

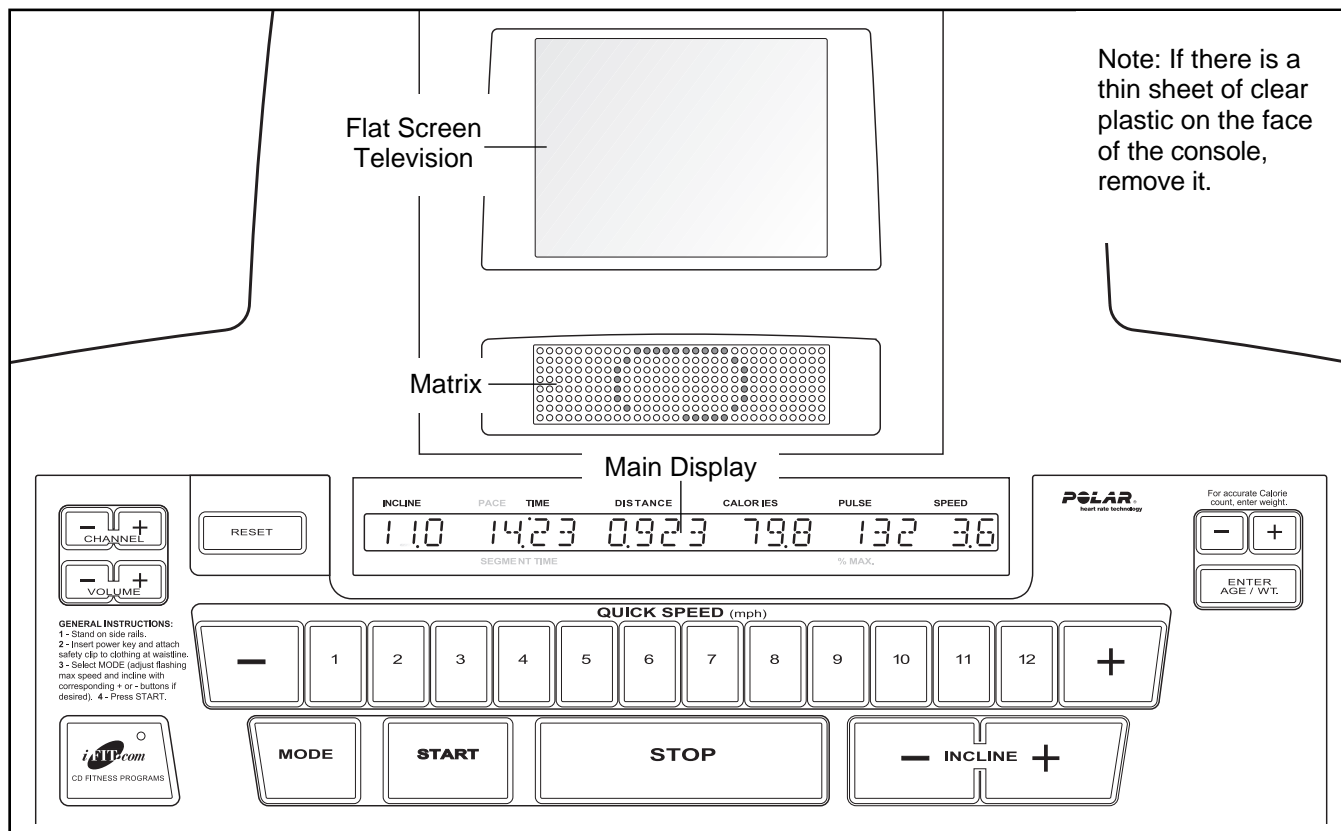

FEATURES OF THE CONSOLE

The state-of-the-art Workout TV console offers an impressive array of features to make your workouts more effective and enjoyable.

When the manual mode of the console is selected, the speed and incline of the treadmill can be changed with a touch of a button. As you exercise, the console will provide instant exercise feedback. You can even measure your heart rate using the built-in pulse sensor.

Six preset workout programs are also offered. Each program automatically controls the speed and incline of the treadmill to give you an effective workout. In addition, the console offers three pulse-driven programs that adjust the speed and incline of the treadmill to keep your heart rate near target levels during your workouts, and a unique fitness test program that measures your relative fitness level. Note: The pulse-driven programs and the fitness test program require the use of a Polar®-compatible chest pulse sensor (not included).

No matter which mode or program you select, the personal TV will allow you to watch the television program of your choice while you exercise.

The console also features new iFIT.com interactive technology. iFIT.com technology is like having a personal trainer right at your side. Using the included audio cable, you can connect your portable CD player to the treadmill and play special iFIT.com CD programs (CDs are available separately). iFIT.com CD programs automatically control the speed and incline of the treadmill as a personal trainer guides you through every step of your workout. High-energy music provides added motivation. Each CD features two programs designed by certified personal trainers. **To order iFIT.com CDs, call toll-free 1-877-363-8449.**

To upgrade your treadmill with the Workout TV console, call toll-free 1-877-363-8449.

HOW TO USE THE WORKOUT TV CONSOLE

The Workout TV console offers exactly the same features as the Basic console, but incorporates a built-in personal TV in addition. Note: The console has the capability to find and store in memory all of the valid TV channels in your area. You can even screen out unwanted channels. Refer to pages 23 to 25 for instructions.

A CATV cable must be connected to the treadmill in order for cable TV stations to be viewed. Refer to HOW TO CONNECT A CATV CABLE on page 10 for instructions.

To use the Workout TV console, follow the instructions on pages 14 to 25 of this manual. To use the personal TV, follow the instructions below.

1 Select the desired channel.

Press the CHANNEL + and – buttons to select a channel. The selected channel will appear in the main display.

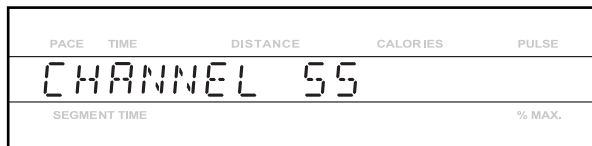

Note: If a satellite receiver, VCR, or DVD player is connected, the channel must be changed at the satellite receiver, VCR, or DVD player.

2 Put on headphones (not included) if desired.

To listen to television programs using headphones, plug your headphones into the indicated jack on the left side of the console.

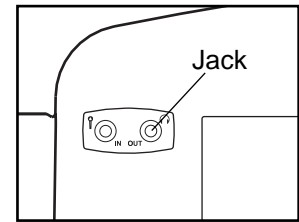

3 Adjust the volume.

Press the VOLUME + and – buttons to select the desired volume. The selected volume setting will appear in the main display.



PREVENTIVE MAINTENANCE

Regular maintenance is necessary for optimal performance and long treadmill life. Please read and follow all instructions below. If the treadmill is not maintained as described, components may wear excessively, the treadmill may be damaged, and the warranty will be voided. If you have questions about maintenance, call Customer Care toll-free at 1-800-201-2109, Monday through Friday, 8 a.m. until 5 p.m. Mountain Time (excluding holidays). **CAUTION: Make sure to remove the key and unplug the power cord before performing any maintenance procedures.**

WEEKLY MAINTENANCE

1. Inspect and properly tighten all external parts of the treadmill.
2. Apply a mild multi-purpose cleaner to a 100% cotton cloth and remove any dust and grime from the handrails, uprights, foot rails, frame, and motor hood. In addition, wipe the walking platform along the sides of the walking belt. **Do not wipe under the walking belt.** Apply a small amount of mild multi-purpose cleaner to a 100% cotton cloth and wipe the console and the screens. **Do not spray cleaner directly onto the treadmill or use ammonia or acid-based cleaners.**
3. Make sure that the walking belt is centered and properly tightened. If it is centered and runs smoothly, do not make any adjustments. If the walking belt needs to be adjusted, refer to pages 33 and 34.

MONTHLY MAINTENANCE

1. Remove the two screws attaching the motor hood and lift off the motor hood. Using a hand-held vacuum, clean the area covered by the motor hood. **Be careful to avoid touching any components.**
2. Check the motor belt for wear and cracks. If the motor belt needs to be replaced, refer to page 44 to order a new motor belt.
3. Plug in the power cord and insert the key into the console. Press the START button. **Be careful to avoid injury; keep your hands away from moving parts and make sure that your clothing cannot become caught in moving parts.** While the walking belt is moving, check the motor for arcing. Next, check the treadmill for unusual noises or odors. If any of these problems exists, call Customer Care toll-free at 1-800-201-2109. **Remove the key and unplug the power cord.** Reattach the motor hood with the two screws.
4. The walking platform should **not** be lubricated before the treadmill is used. However, lubricant should be applied at least once per month. To purchase a lubricant pump or lubricant packets, call Customer Care toll-free at 1-800-201-2109. **CAUTION: Before applying lubricant, remove the key and unplug the power cord.**

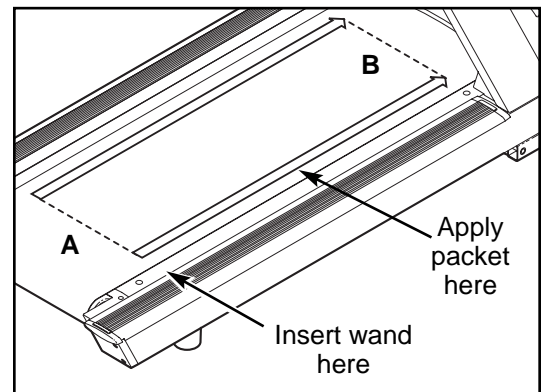
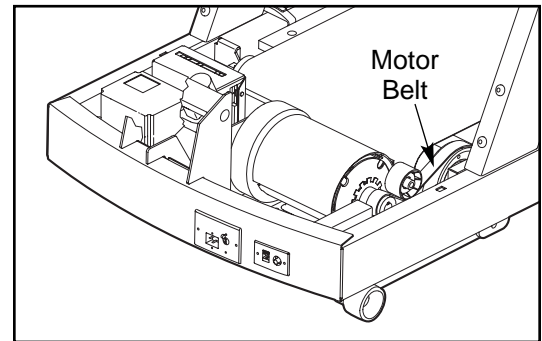

To use a lubricant pump, first prime the pump. Insert the wand under the walking belt in the location shown by dotted line A. Center the nozzles under the walking belt and apply lubricant as you slide the wand forward to dotted line B. Then, pull the wand back out. **To use lubricant packets**, open one packet, reach under one side of the walking belt as far as you can, and apply the entire packet between dotted line A and dotted line B. Then, apply a second packet under the other side of the walking belt in the same way. **After you have applied lubricant using a lubricant pump or lubricant packets, plug in the power cord, insert the key, adjust the speed to 3 mph, and walk on the walking belt for two minutes to spread the lubricant.**

TURNING THE WALKING PLATFORM

Both sides of the walking platform are designed to be used as walking surfaces. Inspect the walking platform periodically for wear. If there is any wood showing through the phenolic coating, or if the surface is damaged, the walking platform should be turned over. The walking platform will need to be turned over after every 6,000 to 7,500 miles. Follow the instructions below to turn over the walking platform.

1. **Remove the key and unplug the power cord.** Remove the two Hood Screws (2) and lift off the Motor Hood (1). Next, remove the two Rear Roller Bolts (82), the two Roller Guard Screws (80), and the Right and Left Roller Guards (81, 83).

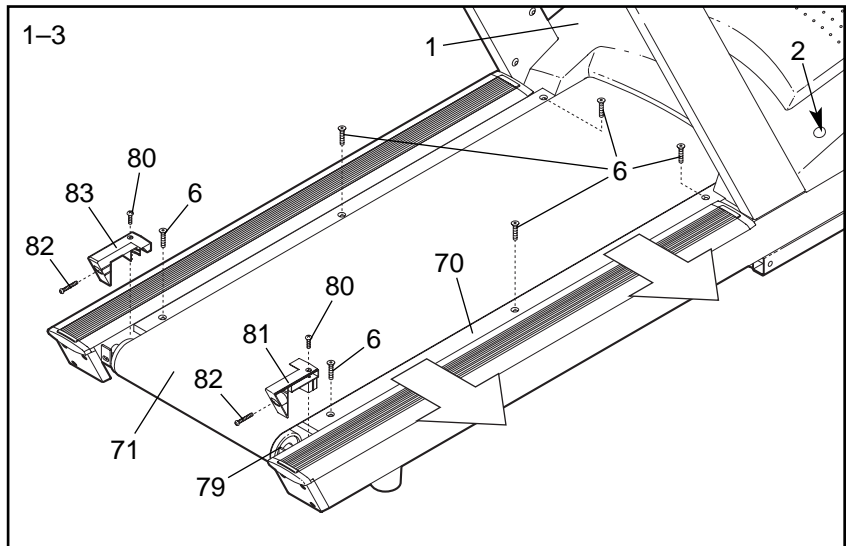

2. Remove the six Platform Screws (6). **(Note: Be very careful when removing the Platform Screws and when handling the Walking Platform [70]. The phenolic coating on the Walking Platform can be chipped or damaged if it is mishandled.)**

Lift the Rear Roller (79) and slide it out of the Walking Belt (71). Lift the Walking Platform (70) a few inches, slide it out of the Walking Belt, turn it over, and then slide it back into the Walking Belt. Slide the Rear Roller back into the Walking Belt. Reattach the six Platform Screws (6).

3. Reattach the Right and Left Roller Guards (81, 83) with the two Roller Guard Screws (80). Insert the Rear Roller Bolts (82) into the Roller Guards and thread them into the Rear Roller (79). Reattach the Motor Hood (1) with the two Hood Screws (2).

4. Next, the Walking Belt (71) will need to be adjusted to the proper tension. Using chalk, make two marks on the Walking Belt exactly 50" apart, as shown in the drawing. Tighten both Rear Roller Bolts (82) until the two chalk marks move apart an additional 3/16" to 1/4". Make sure to keep the Walking Belt centered.

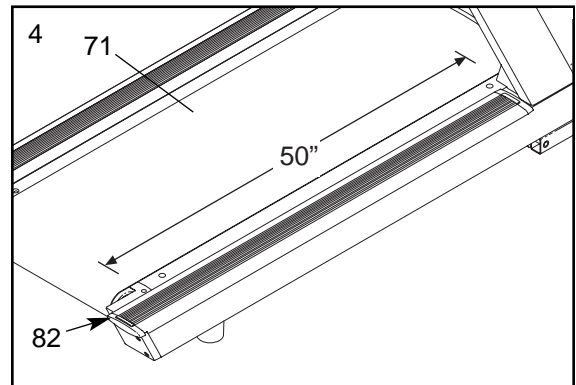

REPLACING THE WALKING PLATFORM

When both sides of the walking platform become worn, the walking platform should be replaced. The walking platform will need to be replaced after every 12,000 to 15,000 miles. Refer to page 44 to order a new walking platform. Follow the instructions above to replace the walking platform.

REPLACING THE WALKING BELT

When the walking belt becomes worn, it should be replaced. The walking belt will need to be replaced after every 12,000 to 15,000 miles. Refer to page 44 to order a new walking belt.

SIX-MONTH PREVENTIVE MAINTENANCE RECORD

Photocopy this form and use it to record the preventive maintenance performed on the treadmill. Each copy of the form can be used for six months (26 weeks). When maintenance is performed, write the date in the appropriate spaces. **Make sure to perform each maintenance procedure as described on pages 29 and 30. If the maintenance procedures are not performed as described, components may wear excessively, the treadmill may be damaged, and the warranty will be voided.** Note: An extra copy of this form is found on page 32.

	Weekly Maintenance			Monthly Maintenance			
	Inspect and tighten all external parts of the treadmill.	Clean the treadmill.	Check the walking belt for proper tension and alignment.	Remove the motor hood and vacuum the motor compartment.	Check the motor belt for cracks and other wear.	Check the motor for arcing; check for noises or odors.	Lubricate the walking platform.
Week 1	/ /	/ /	/ /				
Week 2	/ /	/ /	/ /				
Week 3	/ /	/ /	/ /				
Week 4	/ /	/ /	/ /	/ /	/ /	/ /	/ /
Week 5	/ /	/ /	/ /				
Week 6	/ /	/ /	/ /				
Week 7	/ /	/ /	/ /				
Week 8	/ /	/ /	/ /	/ /	/ /	/ /	/ /
Week 9	/ /	/ /	/ /				
Week 10	/ /	/ /	/ /				
Week 11	/ /	/ /	/ /				
Week 12	/ /	/ /	/ /				
Week 13	/ /	/ /	/ /	/ /	/ /	/ /	/ /
Week 14	/ /	/ /	/ /				
Week 15	/ /	/ /	/ /				
Week 16	/ /	/ /	/ /				
Week 17	/ /	/ /	/ /	/ /	/ /	/ /	/ /
Week 18	/ /	/ /	/ /				
Week 19	/ /	/ /	/ /				
Week 20	/ /	/ /	/ /				
Week 21	/ /	/ /	/ /	/ /	/ /	/ /	/ /
Week 22	/ /	/ /	/ /				
Week 23	/ /	/ /	/ /				
Week 24	/ /	/ /	/ /				
Week 25	/ /	/ /	/ /				
Week 26	/ /	/ /	/ /	/ /	/ /	/ /	/ /

Walking Platform Turned/Replaced	/ /	/ /	Walking Belt Replaced	/ /
----------------------------------	-----	-----	-----------------------	-----

SIX-MONTH PREVENTIVE MAINTENANCE RECORD

Photocopy this form and use it to record the preventive maintenance performed on the treadmill. Each copy of the form can be used for six months (26 weeks). When maintenance is performed, write the date in the appropriate spaces. **Make sure to perform each maintenance procedure as described on pages 29 and 30. If the maintenance procedures are not performed as described, components may wear excessively, the treadmill may be damaged, and the warranty will be voided.**

	Weekly Maintenance			Monthly Maintenance			
	Inspect and tighten all external parts of the treadmill.	Clean the treadmill.	Check the walking belt for proper tension and alignment.	Remove the motor hood and vacuum the motor compartment.	Check the motor belt for cracks and other wear.	Check the motor for arcing; check for noises or odors.	Lubricate the walking platform.
Week 1	/ /	/ /	/ /				
Week 2	/ /	/ /	/ /				
Week 3	/ /	/ /	/ /				
Week 4	/ /	/ /	/ /	/ /	/ /	/ /	/ /
Week 5	/ /	/ /	/ /				
Week 6	/ /	/ /	/ /				
Week 7	/ /	/ /	/ /				
Week 8	/ /	/ /	/ /	/ /	/ /	/ /	/ /
Week 9	/ /	/ /	/ /				
Week 10	/ /	/ /	/ /				
Week 11	/ /	/ /	/ /				
Week 12	/ /	/ /	/ /				
Week 13	/ /	/ /	/ /	/ /	/ /	/ /	/ /
Week 14	/ /	/ /	/ /				
Week 15	/ /	/ /	/ /				
Week 16	/ /	/ /	/ /				
Week 17	/ /	/ /	/ /	/ /	/ /	/ /	/ /
Week 18	/ /	/ /	/ /				
Week 19	/ /	/ /	/ /				
Week 20	/ /	/ /	/ /				
Week 21	/ /	/ /	/ /	/ /	/ /	/ /	/ /
Week 22	/ /	/ /	/ /				
Week 23	/ /	/ /	/ /				
Week 24	/ /	/ /	/ /				
Week 25	/ /	/ /	/ /				
Week 26	/ /	/ /	/ /	/ /	/ /	/ /	/ /

Walking Platform Turned/Replaced	/ /	/ /	Walking Belt Replaced	/ /
----------------------------------	-----	-----	-----------------------	-----

TROUBLE-SHOOTING

Most treadmill problems can be solved by following the steps outlined in this section. Find any symptoms that apply, and follow the steps listed. If further assistance is needed, please call Customer Care toll-free at 1-800-201-2109, Monday through Friday, 8 a.m. until 5 p.m. Mountain Time (excluding holidays).

1. SYMPTOM: THE POWER DOES NOT TURN ON

- a. Make sure that the power cord is plugged into a properly grounded outlet. (Refer to page 10.)
- b. Make sure that the key is inserted into the console.
- c. Check the on/off circuit breaker located on the treadmill near the power cord. Make sure that the on/off circuit breaker is switched to the on position.

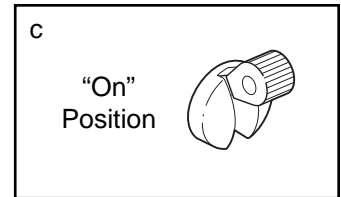

2. SYMPTOM: THE POWER TURNS OFF DURING USE

- a. Check the on/off circuit breaker located on the treadmill near the power cord. (See drawing 1. c. above.) Make sure that the on/off circuit breaker is switched to the on position.
- b. Make sure that the power cord is plugged in.
- c. Remove the key from the console. Reinsert the key into the console.
- d. If the power still turns off during use, please call Customer Care toll-free.

3. SYMPTOM: THE WALKING BELT SLOWS WHEN WALKED ON

- a. If the walking belt is overtightened, performance may decrease and the walking belt may be damaged. If the walking belt is properly tightened, you should be able to lift each side of the walking belt 1 to 2 inches off the walking platform. **If adjustments need to be made, first remove the key and unplug the power cord.** Using the included allen wrench, turn both roller adjustment bolts counterclockwise 1/4 of a turn. Be careful to keep the walking belt centered. Plug in the power cord, insert the key, and use the treadmill for a few minutes. Repeat until the walking belt is properly tightened.

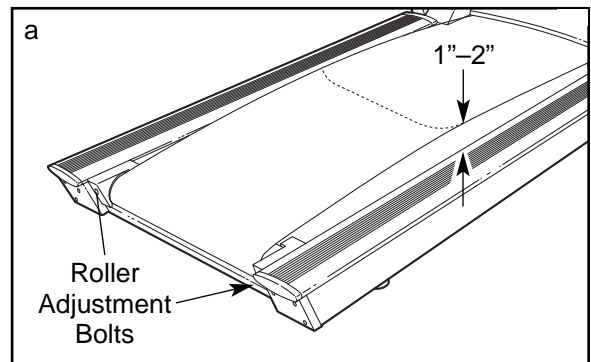

- b. If the walking belt still slows when walked on, please call Customer Care toll-free.

4. SYMPTOM: THE WALKING BELT IS OFF-CENTER

a. **If the walking belt has shifted to the left: Remove the key and unplug the power cord.** Using the included allen wrench, turn the roller adjustment bolts in the directions shown, 1/4 of a turn each. Be careful not to overtighten the walking belt. Plug in the power cord, insert the key and use the treadmill for a few minutes. Repeat until the walking belt is centered.

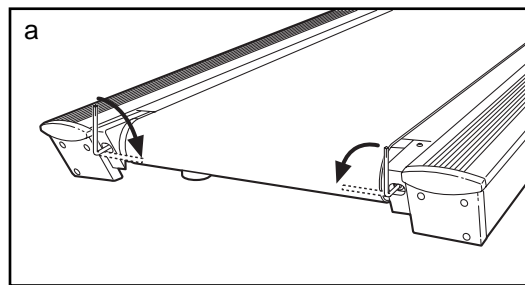

b. **If the walking belt has shifted to the right: Remove the key and unplug the power cord.** Using the included allen wrench, turn the roller adjustment bolts in the directions shown, 1/4 of a turn each. Be careful not to overtighten the walking belt. Plug in the power cord, insert the key and use the treadmill for a few minutes. Repeat until the walking belt is centered.

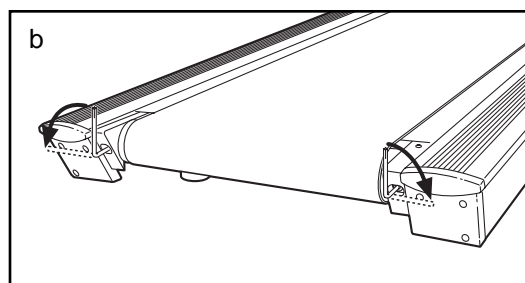

c. **If the walking belt slips when walked on: Remove the key and unplug the power cord.** Using the included allen wrench, turn both roller adjustment bolts clockwise 1/4 of a turn. When the walking belt is properly tightened, you should be able to lift each side of the walking belt 1 to 2 inches off the walking platform. The center of the walking belt should just touch the walking platform. Make sure to keep the walking belt centered. Plug in the power cord, insert the key and run the treadmill for a few minutes. Repeat until the walking belt is properly tightened.

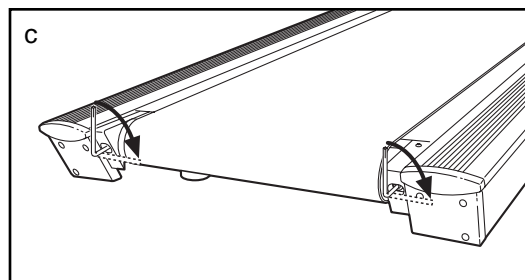

5. SYMPTOM: THE WALKING BELT STOPS OR THE INCLINE CANNOT BE ADJUSTED EVEN THOUGH THE CONSOLE REMAINS LIT

a. This indicates that a controller error may have occurred. To correct the problem, refer to step 8 on page 23.

6. SYMPTOM: THE INCLINE SYSTEM DOES NOT FUNCTION PROPERLY OR THE TREADMILL DOES NOT APPEAR TO BE AT THE INCLINE LEVEL SHOWN IN THE MAIN DISPLAY

a. The incline system may need to be calibrated. To initiate the calibration routine, hold down the INCLINE + button and the INCLINE – button simultaneously for three seconds. During the calibration routine, the treadmill will automatically rise to the highest incline level and then return to the lowest incline level.

b. If the incline system still does not function properly, please call Customer Care toll-free.

7. SYMPTOM: THE WORDS LUBRICATE DECK APPEAR EVERY FEW MINUTES IN THE MAIN DISPLAY

a. If the words LUBRICATE DECK appear in the main display, the walking platform should be checked for adequate lubricant. Follow the instructions in step 4 on page 29 to lubricate the walking platform if necessary. After you have lubricated the walking platform, refer to HOW TO RESET THE LUBE REMINDER on page 25. **If this is not done, the words LUBRICATE DECK will continue to appear.**

EXERCISE GUIDELINES

FACTORS IN A SENSIBLE DIET

- Choose high-fiber, low-fat, and low-sugar foods: fruits, vegetables, and whole grains.
- Eat at least five servings of fruits and vegetables daily.
- Reduce red meat consumption; eat lean meat, white meat, and fish.
- Choose healthful snacks; bring healthful foods with you to work or in the car.
- Eat regular meals or mini-meals. Control your portion size—don't binge or overeat. Eat slowly.
- Reduce fast food and pre-packaged meals.
- Pay attention to fat content and calories.
- Limit alcoholic beverages and caffeine.
- Drink at least eight to ten glasses of water daily.

EXERCISE STEPS

The following nine steps for designing your exercise program were developed by exercise physiologists at NordicTrack. The actual exercise you perform is only a part of a safe and effective training program. There are many other aspects to developing a life-long commitment to physical fitness.

1 Consult your physician before beginning any exercise program.

A medical examination or consultation with your physician is essential.

2 Establish personal fitness goals.

Set attainable, realistic goals. Reward yourself when you meet your goals. Remember, your goals should act as a guide for your workout program.

3 Determine your target heart rate.

Your *target heart rate* (THR), is the rate at which you would like your heart to work during aerobic exercise. It is expressed as a percentage of your *maximum heart rate* (MHR). MHR is the maximum number of times that your heart can pump during one minute. To determine your approximate MHR, subtract your age (in years) from 220. This is only an estimation of your MHR—only clinical stress testing can provide an actual MHR reading.

Once you have determined your MHR, you can establish your target heart rate zone. Beginning exercisers may wish to start at 60 to 70 percent of their MHR. This level is called the *Health* level. Exercise at 70 to 85 percent of your MHR for the optimal training, aerobic, or cardiovascular level—the *Fitness* level. Advanced exercisers, or those wishing to do sports, athletic conditioning, or interval training workouts should exercise at 80 to 85 percent of the MHR for short periods of time. The chart below shows Target Heart Rate Zones for Health, Fitness, and Advanced exercisers.

Be sure to check your heart rate at least twice during an aerobic conditioning session. First, check your heart rate five minutes into your workout to be sure that you are at the proper intensity. Then, check it again near the end of your workout to verify that you have maintained your target heart rate for the recommended period of time.

TARGET HEART RATE ZONES

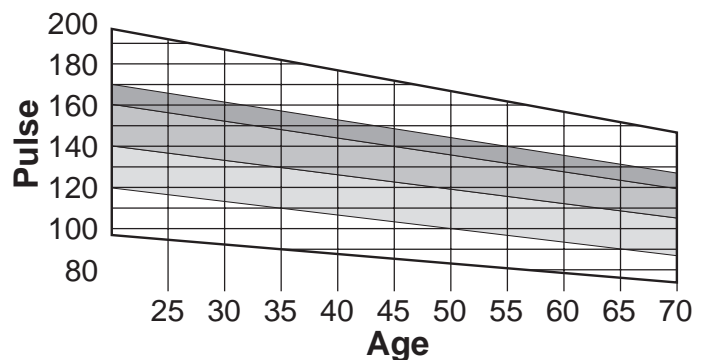

Health	Fitness	Advanced
Beginner, low-intensity + long duration = fat burning	Optimal training, aerobic or cardiovascular	Sports, athletic conditioning, interval training

WEIGHT LOSS TIPS

At least four, 30-minute workouts per week, along with a reduced-calorie diet, are recommended if you are trying to lose weight. However, be sure to stay within your target heart rate zone and exercise a maximum of 5 days per week for 60 minutes per workout.

Good posture is the key to safe, comfortable workouts. Keep your chin up and your head facing forward. Align your head and shoulders with your hips. Avoid leaning forward. Keep your back straight.

4 Warm up before you begin.

A warm-up routine prepares your body and mind for vigorous exercise. It also helps provide insurance against injury and soreness. Warm up with two to five minutes of slow exercise, at minimal intensity.

5 Stretch after your warm-up.

A pliable, well-stretched muscle is less susceptible to injury. Perform the recommended stretches on a smooth, flat surface.

The correct form for several stretches is described below (refer to the drawings at the right). Be sure to move slowly as you stretch—never bounce.

1. Toe Touch Stretch—Sit with your knees bent slightly and slowly bend forward from your hips. Allow your back and shoulders to relax as you reach toward your toes as far as possible. Hold for 15 to 30 seconds, then relax. Repeat 3 times. Stretches: Hamstrings, back of knees, and back.

2. Calf/Achilles Stretch—With one leg in front of the other, reach forward and place your hands against a wall. Keep your back leg straight and your back foot flat on the floor. Bend your front leg, lean forward, and move your hips toward the wall. Hold for 15 to 30 seconds, then relax. Repeat 3 times for each leg. To cause further stretching of the achilles tendons, bend your back leg as well. Stretches: Calves, achilles tendons, and ankles.

3. Hamstring Stretch—Sit with one leg extended. Bring the sole of the opposite foot toward you and rest it against the inner thigh of your extended leg. Reach toward your toes as far as possible. Hold for 15 to 30 seconds, then relax. Repeat 3 times for both legs. Stretches: Hamstrings, lower back, and groin.

4. Inner Thigh Stretch—Sit with the soles of your feet together and your knees outward. Pull your feet toward your groin area as far as possible. Hold for 15 to 30 seconds, then relax. Repeat 3 times. Stretches: Quadriceps and hip muscles.

5. Quadriceps Stretch—With one hand against a wall for balance, reach back and grasp one foot with your other hand. Bring your heel as close to your buttocks as possible. Hold for 15 to 30 seconds, then relax. Repeat 3 times for each leg. Stretches: Quadriceps and hip muscles.

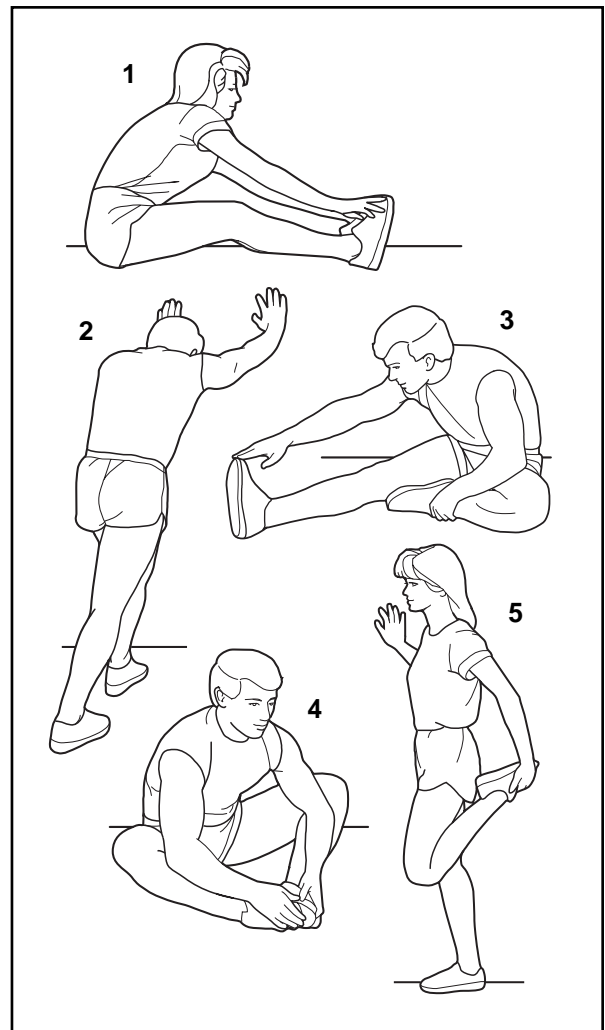

BENEFITS OF AEROBIC EXERCISE

- Effective weight loss and management
- Added protection from heart disease
- Increased strength and health of bones
- Higher levels of energy for greater productivity during the day
- Healthy stress relief from a pressure-packed day
- Greater intellectual capacity and productivity

6 Get FIT with NordicTrack

Effective aerobic exercise has three major parts: *frequency*, *intensity*, and *time*. The acronym "FIT" may help you to remember these three parts:

F "F" stands for the frequency of your workouts. Three to five workouts per week are recommended. Exercise at least four times a week for weight loss.

I "I" refers to the intensity of your workout. Check your heart rate at least twice during your aerobic exercise session: once during the session and once again at the end. Maintain a workout intensity level within your Target Heart Rate Zone. You can measure your heart rate using the handgrip pulse sensor or the method described below:

1. Lower your wrist below your heart level. This will make your heart rate stronger and easier to feel.

2. Using the index and middle fingertips of your right hand, touch your left wrist, one-fourth inch from your wrist joint, at the base of your thumb.

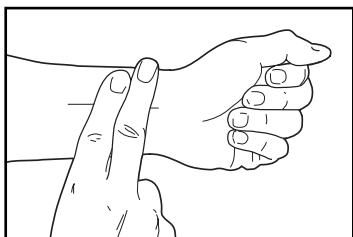

3. Apply minimal pressure with both fingers—let the beat come to your fingers. If you can't find your pulse, use the opposite wrist and hand.

T "T" is for the time or duration of your workout. Beginning exercisers may wish to start with 5 to 10 minutes of aerobic activity. Those in average physical condition should exercise for 20 to 30 minutes. Highly fit people, or people who want to lose weight, should exercise for 30 to 60 minutes. The key is to maintain your target heart rate for the duration of the workout period.

Remember to take it slowly. Fitness is a lifelong commitment. If you can't go the full 20 minutes from the start, which is common, try to exercise for five minutes at a time, a couple of times a day. Recent research indicates that several short workouts in one day can also provide fitness benefits. Gradually, your stamina will increase and it will become easier to exercise for longer periods of time.

7 Cool down after aerobic exercise.

Keep moving! It is important that you cool down properly to allow your heart rate to decrease slowly after it has been elevated. This helps the blood flow from your extremities back to your heart. Keep your legs moving on the treadmill at a slower pace for at least five minutes following the aerobic phase.

8 Stretch again at the end of your exercise session.

Stretching after exercise reduces muscle soreness. See step 5 on page 36.

9 Participate in strength training.

"Balanced fitness, including both strength training and aerobic exercise, can do more to ensure a happy life than just about anything else known to medical science today."

—Kenneth Cooper, M.D., M.P.H., founder of The Cooper Institute For Aerobic Research, Dallas, Texas.

A strength-training program increases your lean muscle mass. Lean muscle mass aids in burning body fat. With additional muscle mass and strength, you will receive the full benefits of an exercise program. You will also be less prone to injuries during the aerobic phase of your workout.

WORKOUT TIPS

Full-body conditioning helps take care of many of life's aches and pains. However, it takes time for your body to adapt to any new routine. Below are some tips that will help ease you into your new NordicTrack routine.

- Begin and end each exercise session with the stretches on page 36. Stretch in a smooth, controlled manner. Hold each stretch for 15 to 30 seconds. You may experience some initial muscle soreness and discomfort as a result of exercising inactive or poorly stretched muscles. For maximum benefit, a stretching routine must be performed every day.
- Be aware of your body's signals and react to them accordingly. At your correct exercise intensity, you should be able to whistle or maintain a normal conversation. If during exercise you feel tired, light-headed, dizzy, or nauseated, stop exercising immediately and consult your physician. Your heart rate may also be affected by such things as stress, caffeine, nicotine, or prescription drugs.

WORKOUT PROGRAMS

The *Health* level typically lasts four to six weeks. At this level you should be concerned with slowly improving your fitness level and endurance.

Take it slowly. Set mini-goals for yourself. You may want to begin your fitness routine with three or four short, 5- or 10-minute workouts in a day.

Move on to the *Fitness* Level only when you feel ready and your heart rate has moved below your target heart rate zone.

The *Fitness* level usually lasts 12 to 20 weeks. (It may last longer, depending on your fitness goals.) At this level you should strive to achieve your fitness goals.

Set realistic short- and long-term goals for yourself. Frequently re-evaluate your fitness goals and reward yourself as you are successful.

Move on to the *Advanced* Level when you have reached your fitness goals and your heart rate has moved below your target heart rate zone.

Work out at the *Advanced* level once you have reached your desired fitness goals. It is intended to be a maintenance program and should continue on a regular, long-term basis.

You may wish to add *Interval Training* to your maintenance program as well. Interval training will add variety to your workout routine and further condition your cardiovascular system. Interval training has been shown to promote higher levels of aerobic conditioning. It consists of spurts of high-intensity activity followed by active rest periods of exercise at a lower intensity. For example, a one-minute spurt of high-resistance, fast exercise is followed by a two- to three-minute active rest period of low-resistance, slow exercise. The duration of these periods should be based more on how you feel rather than time. A sequence such as this should be repeated 5 to 20 times during your workout session.

Heart Rate Intensity								
HEART RATE INTENSITY	Age	20	30	40	50	60	70	80
60% - 70% HEALTH	b.p.m.	120-140	114-133	108-126	102-119	96-112	90-105	84-98
70% - 85% FITNESS	b.p.m.	140-170	133-162	126-153	119-145	112-136	105-128	98-119
80% - 85% ADVANCED	b.p.m.	160-170	152-162	144-153	136-145	128-136	120-128	112-119

LIMITED WARRANTY

Limited Warranty on Commercial Equipment

FreeMotion Fitness, Inc. warrants that all new equipment will be free of manufacturing defects in workmanship and materials, becoming effective at the date of original installation. Parts repaired or replaced under the terms of this warranty will be warranted for the remainder of the original warranty period only. Labor must be performed at a FreeMotion Fitness commercial service facility or by a FreeMotion Fitness authorized commercial service provider.

Terms and Conditions of Coverage

1. Warranty applies only while:
 - (A) it remains in the possession of the original purchaser and proof of purchase is demonstrated,
 - (B) it has not been subject to accident, misuse, abuse, improper service, or modification, and
 - (C) claims are made within the warranty period.
2. All coverage is provided by specific Product according to the guidelines listed on the chart below.
3. If the Product or any covered part must be returned to a service facility for repairs, We, FreeMotion Fitness, Inc., will pay all transportation and insurance charges for the first year. We must approve transportation and insurance previous to shipping. You are responsible for transportation and insurance charges during the remaining years.
4. We will ship to you any new or rebuilt replacement part or component, or, at our option, replace the Product. Such replacement parts are warranted for the remaining portion of the original warranty period.
5. This warranty does not cover damage or equipment failure caused by electric wiring not in compliance with electrical codes or FreeMotion Fitness owner's manual specifications, or failure to provide reasonable and necessary maintenance as outlined in the owner's manual. Any failures or damage caused by unauthorized service, misuse, accident, negligence, improper assembly or installation, debris resulting from any destruction activities in the Product's environment, rust or corrosion as a result of the Product's location, alterations or modifications without written authorization, or by failure on your part to use, operate, and maintain the Product as set in your owner's manual will void this warranty. **All terms of this warranty are void if this Product is moved beyond the continental borders of the United States of America (excluding Alaska, Hawaii, and Canada) and are then subject to the terms provided by that country's local authorized FreeMotion Fitness representative.**
6. During the labor period, FreeMotion Fitness, Inc. compensates Servicicers for warranty trips within their normal service area to repair Product at the consumer's location. You may be charged a trip charge outside the service area.
7. FreeMotion Fitness, Inc. Limited Warranty service may be obtained by contacting the authorized dealer from whom you purchased the Product, or by calling Customer Care at 1-800-201-2109.
8. Product limited warranty is void when Product is installed in a country other than where sold.

Limited warranty does not apply to:

1. Repairs performed on Product with missing, altered, or defaced serial numbers.
2. Service calls to correct installation of the Product or instruct owners on how to use the Product.
3. Repair pick-up, delivery, or freight charges other than specified above.
4. Any labor costs incurred beyond the applicable labor warranty period.

Lifetime Warranty

Frame—excludes labor, handlebar assembly, bolted components, or attached components that are not welded to the base powder coated frame.

AC Motor—excludes labor, motor controller, bolted components, or attached components to the AC motor.

Your Responsibility

Retain proof of purchase; use, operate, and maintain the Product as specified in the Owner's Manual; notify Customer Care of any defect within 10 days after discovery of the defect; if instructed, return any defective part for replacement, or, if necessary, the entire Product for repair.

Owner's Manual

It is very important that you read the Manual before operating the Product. Remember to perform the periodic maintenance requirements specified in the Manual to assure proper operation and your continued satisfaction.

Receipt of Parts and Service

Simply call Customer Care toll-free at 1-800-201-2109, Monday through Friday from 8 a.m. to 5 p.m. Mountain Time, and give your name, address, and the serial number of your Product. A representative will tell you how to get a replacement part, or, if necessary, arrange for service where your Product is located or advise you on how and where to ship the Product for service.

Before Shipping:

1. Obtain a Return Authorization Number (RA#) from Customer Care.
2. Securely pack your Product.
3. Write the RA# on the outside of the carton.
4. Insure the Product.
5. Include a letter explaining the defect or problem and a copy of your proof of purchase if you believe the service is covered by warranty.

Exclusive Warranty

FreeMotion Fitness, Inc. is not responsible or liable for indirect, special, or consequential damages arising out of, or in connection with, the use or performance of the Product or damages with respect to any economic loss, loss of property, loss of revenues or profits, loss of enjoyment or use, costs of removal or installation, or other consequential damages of whatsoever nature. Some states do not allow the exclusion or limitation of incidental or consequential damages. Accordingly, the above limitation may not apply to you. The warranty extended hereunder is in lieu of any and all other warranties and any implied warranties of merchantability or fitness for a particular purpose is limited in its scope and duration to the terms set forth herein. Some states do not allow limitations on how long an implies warranty lasts. Accordingly, the above limitation may not apply to you.

Unauthorized Changes to Warranty

No one is authorized to change, modify, or extend the terms of this limited warranty.

State Laws

This warranty gives you specific legal rights and you may have other rights which vary from state to state.

	Model	Lifetime	4 Years	2 Years	1 Year	6 Months
Treadmill	CTL82520	Motor, frame	Rollers	Parts	Belt, deck, labor	Grips, labels, face plates, wheels
	CTL85020	Motor, frame	Rollers	Parts	Belt, deck, labor	Grips, labels, face plates, wheels
Incline Trainer™	CTK6252	Motor, frame	Rollers	Parts	Labor, belt, deck	Grips, labels, face plates, wheels
	CTK6502	Motor, frame	Rollers	Parts	Labor, belt, deck	Grips, labels, face plates, wheels

PART LIST—MODEL NOS. CTL82520, CTL85020

R0402A

To locate the parts listed below, refer to the EXPLODED DRAWING on pages 42 and 43.

Key No.	Qty.	Description	Key No.	Qty.	Description	Key No.	Qty.	Description
1	1	Motor Hood	53	4	Motor Mount Washer	105	2	Belt Guide Bolt
2	2	Hood Screw	54	1	High Voltage Decal	106	1	Voltage Decal (Small)
3	2	Sensor Bracket Screw	55	4	Motor Bolt	107	5	Cable Tie
4	4	Hood Mounting Clips	56	1	Power Supply Box	108	2	Belt Guide
5	2	Rear Foot	57	1	Power Wire Harness	109	1	Motor Controller Box
6	6	Platform Screw	58	1	Wiring Plate (Right)	110	1	Rear Endcap (Right)
7	6	Isolator	59	1	#10 Screw Allen Wrench	111	1	Motor Flywheel
8	2	Breaker Screw	60	1	CD Holder Foam (Long)	112	1	Motor Pulley
9	6	Isolator Nut	61	1	Incline Motor	113	1	Rear Foot Locknut
10	1	Foot Rail (Left)	62	1	Incline Motor Bolt (Lower)	114	1	Foam Grip (Left)
11	2	Foot Rail Inset	63	1	Cup Holder Foam	115	2	Rear Roller Adj. Washer
12	1	Wiring Plate (Left)	64	2	Wheel Bolt	116	2	Wheel Washer
13	1	Front Endcap (Left)	65	2	Wheel	117	1	Right Foam Grip
14	1	Belt Tension Bolt	66	2	Incline Leg Bolt	118	2	Nylon Incline Washer
15	4	Pulley Screw	67	2	Incline Leg Nut	119	2	Ground Screw
16	2	Outlet Bolt	68	4	Mounting Clips	120	2	Hood Bracket (Back)
17	1	TV Cable (Short)	69	1	Incline Leg	121	1	Incline Motor Spacer
18	1	Power Cord Bracket	70	1	Walking Platform	122	4	Pulse Sensor
19	2	Bracket Screw	71	1	Walking Belt	123	2	Lock Washer
20	1	Motor Belt	72	1	Front Endcap (Right)	124	4	Pulse Sensor Base
21	1	Idler Bolt	73	1	Front Roller/Pulley	#	1	41" Wire Harness
22	2	Outlet Nut	74	22	Foot Rail Screw/ Power Box Screw	#	1	28" Wire Harness, 3 Wire
23	1	Belt Tension Nut				#	1	25" Wire Harness, 5 Wire
24	2	Frame Inserts	75	1	Foot Rail (Right)	#	1	22" Wire Harness
25	1	Belt Tension Wheel	76	1	Frame	#	1	20" Wire Harness, 8 Wire
26	1	Front Roller Bolt	77	14	Small Insert	#	1	20" Wire Harness, 3 Wire
27	2	TV Cable Grommet	78	8	Endcap Screw	#	1	12" Green Wire, 2 Ring
28	2	Ground Nut	79	1	Rear Roller	#	1	7" Green Wire, M/Ring
29	1	Static Decal	80	2	Roller Guard Screw	#	1	4" Green Wire F/Ring
30	1	Belt Tension Spring	81	1	Roller Guard (Right)	#	1	4" Green Wire F/Ring, 14Ga
31	4	Motor Nut	82	2	Rear Roller Adj. Bolt	#	1	4" Black Wire, 2F
32	1	Belt Tension Bracket	83	1	Roller Guard (Left)	#	1	4" White Wire, M/F
33	1	Speed Disk	84	1	Rear Endcap (Left)	#	1	Wire w/Resistor
34	3	Speed Disk Screw	85	1	Cup Holder Insert	#	1	Optional Console
35	2	Sensor Screw	86	1	CD Holder Insert	#	1	User's Manual
36	1	Speed Sensor	87	1	Key/Clip			
37	1	CD Holder Foam	88	1	Console			
38	1	Sensor Bracket	89	1	Console Base			
39	2	Sensor Bracket Nut	90	2	Handrail Endcap			
40	1	Motor	91	1	Handrail			
41	1	Motor Isolator	92	13	Console Back Screw			
42	2	Incline Motor Nut (Top)/ Idler Nut	93	4	Console Back Screw			
43	1	Incline Motor Bolt (Top)	94	1	Console Back			
44	4	Pulse Sensor Screw	95	1	Upright (Right)			
45	1	7" Filter Wire	96	8	Upright Bolt			
46	2	Hood Bracket (Front)	97	1	Upright (Left)			
47	1	On/Off Circuit Breaker	98	1	TV Cable			
48	1	Power Cord	99	8	Handrail Bolt			
49	1	Power Cord Outlet	100	1	Upright Wire Harness			
50	2	Wheel Spacer	101	1	Controller Wire			
51	1	Warning Decal	102	1	Allen Wrench (7/32")			
52	4	Motor Bushing	103	1	Allen Wrench (5/16")			
			104	1	Tie Block			

* Includes all parts shown in the box

These parts are not illustrated

R0402A

EXPLODED DRAWING—MODEL NOS. CTL82520, CTL85020 R0402A

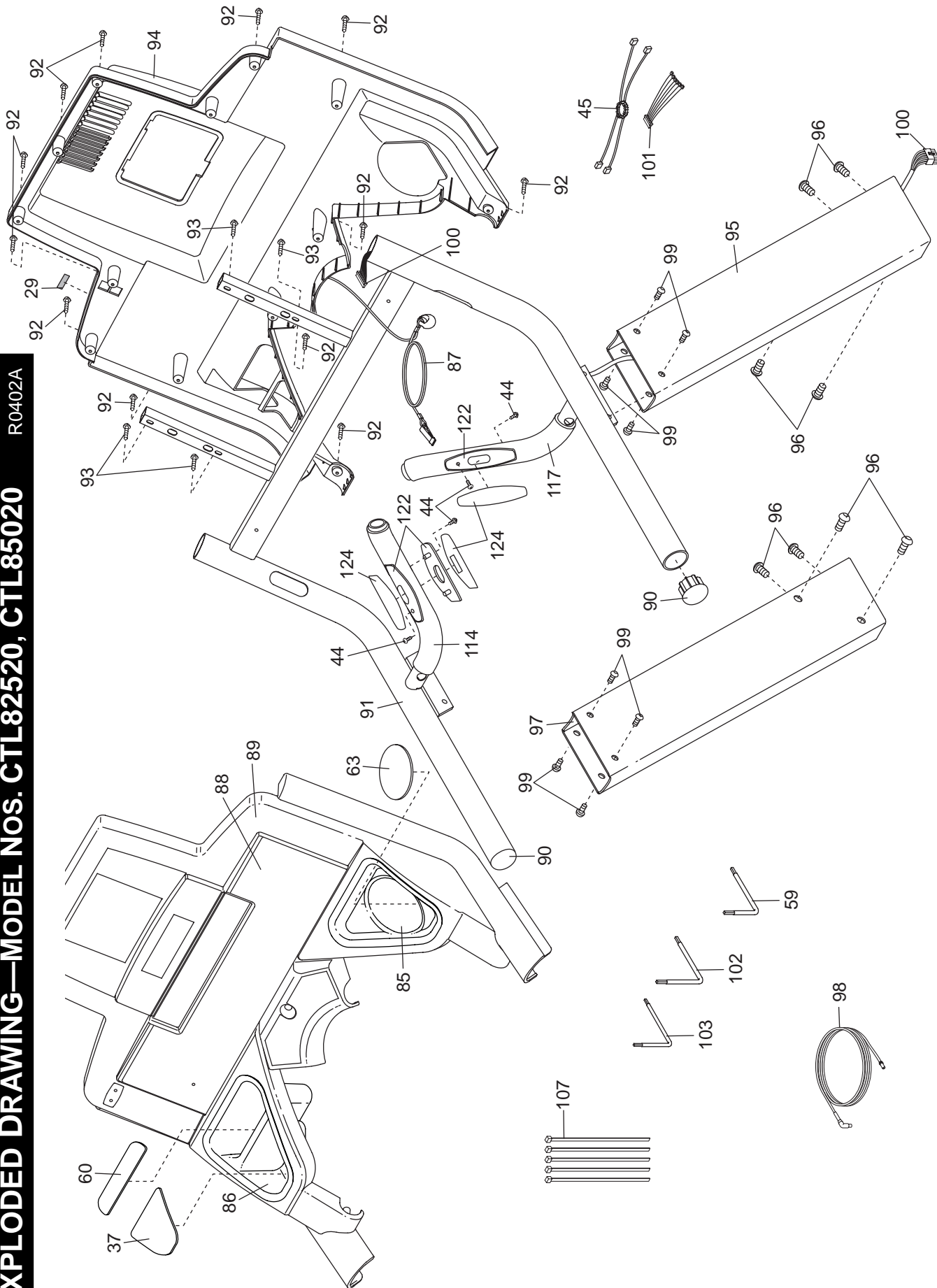

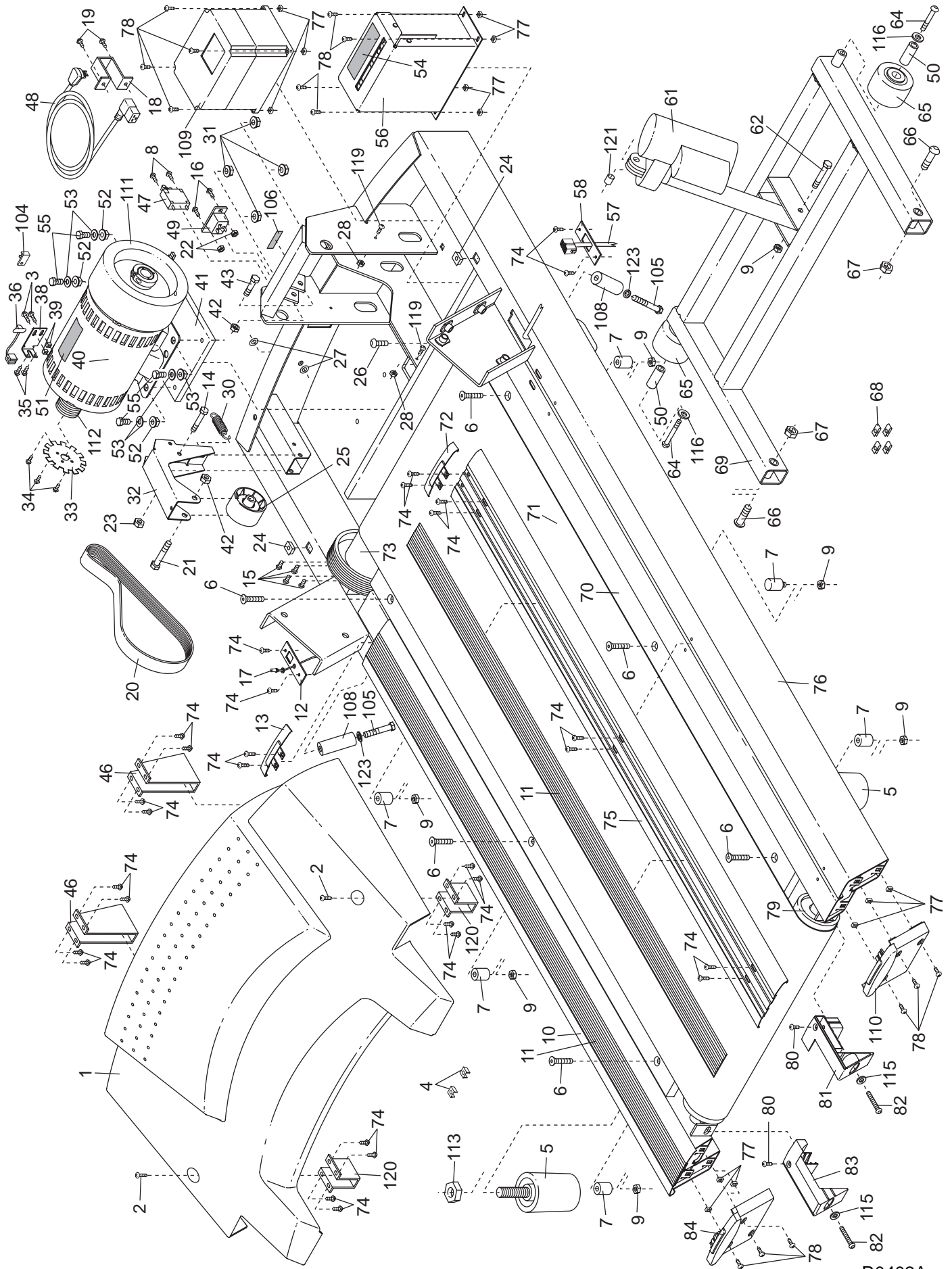

HOW TO ORDER REPLACEMENT PARTS

To order replacement parts, call Customer Care toll-free at 1-800-201-2109, Monday through Friday, 8 a.m. until 5 p.m. Mountain Time (excluding holidays). When ordering parts, please be prepared to give the following information:

- The MODEL NUMBER OF THE PRODUCT (CTL82520 or CTL85020)
- The NAME OF THE PRODUCT (NordicTrack® 9600 treadmill)
- The SERIAL NUMBER OF THE PRODUCT (see the front cover of this manual for the location)
- The KEY NUMBER and DESCRIPTION OF THE PART(S) (see the PART LIST and the EXPLODED DRAWING on pages 41 to 43).

FREEMOTION FITNESS INC™

FreeMotion Fitness, Inc. • 1096 Elkton, Suite 600 • Colorado Springs, CO 80907