



**Mellanox 1U EDR 100Gb/s InfiniBand Switch
Systems Hardware User Manual
Models: SB7700/SB7790**

Rev 1.2

NOTE:

THIS HARDWARE, SOFTWARE OR TEST SUITE PRODUCT (“PRODUCT(S)”) AND ITS RELATED DOCUMENTATION ARE PROVIDED BY MELLANOX TECHNOLOGIES “AS-IS” WITH ALL FAULTS OF ANY KIND AND SOLELY FOR THE PURPOSE OF AIDING THE CUSTOMER IN TESTING APPLICATIONS THAT USE THE PRODUCTS IN DESIGNATED SOLUTIONS. THE CUSTOMER’S MANUFACTURING TEST ENVIRONMENT HAS NOT MET THE STANDARDS SET BY MELLANOX TECHNOLOGIES TO FULLY QUALIFY THE PRODUCT(S) AND/OR THE SYSTEM USING IT. THEREFORE, MELLANOX TECHNOLOGIES CANNOT AND DOES NOT GUARANTEE OR WARRANT THAT THE PRODUCTS WILL OPERATE WITH THE HIGHEST QUALITY. ANY EXPRESS OR IMPLIED WARRANTIES, INCLUDING, BUT NOT LIMITED TO, THE IMPLIED WARRANTIES OF MERCHANTABILITY, FITNESS FOR A PARTICULAR PURPOSE AND NONINFRINGEMENT ARE DISCLAIMED. IN NO EVENT SHALL MELLANOX BE LIABLE TO CUSTOMER OR ANY THIRD PARTIES FOR ANY DIRECT, INDIRECT, SPECIAL, EXEMPLARY, OR CONSEQUENTIAL DAMAGES OF ANY KIND (INCLUDING, BUT NOT LIMITED TO, PAYMENT FOR PROCUREMENT OF SUBSTITUTE GOODS OR SERVICES; LOSS OF USE, DATA, OR PROFITS; OR BUSINESS INTERRUPTION) HOWEVER CAUSED AND ON ANY THEORY OF LIABILITY, WHETHER IN CONTRACT, STRICT LIABILITY, OR TORT (INCLUDING NEGLIGENCE OR OTHERWISE) ARISING IN ANY WAY FROM THE USE OF THE PRODUCT(S) AND RELATED DOCUMENTATION EVEN IF ADVISED OF THE POSSIBILITY OF SUCH DAMAGE.



Mellanox Technologies
350 Oakmead Parkway Suite 100
Sunnyvale, CA 94085
U.S.A.
www.mellanox.com
Tel: (408) 970-3400
Fax: (408) 970-3403

© Copyright 2015. Mellanox Technologies. All Rights Reserved.

Mellanox®, Mellanox logo, BridgeX®, ConnectX®, Connect-IB®, CoolBox®, CORE-Direct®, GPUDirect®, InfiniBridge®, InfiniHost®, InfiniScale®, Kotura®, Kotura logo, MetroX®, MLNX-OS®, PhyX®, ScalableHPC®, SwitchX®, TestX®, UFM®, Virtual Protocol Interconnect®, Voltaire® and Voltaire logo are registered trademarks of Mellanox Technologies, Ltd.

CyPU™, ExtendX™, FabricIT™, FPGADirect™, HPC-X™, Mellanox Care™, Mellanox CloudX™, Mellanox NEO™, Mellanox Open Ethernet™, Mellanox PeerDirect™, Mellanox Virtual Modular Switch™, MetroDX™, NVMeDirect™, StPU™, Switch-IB™, Unbreakable-Link™ are trademarks of Mellanox Technologies, Ltd.

All other trademarks are property of their respective owners.

Table of Contents

Revision History	7
About this Manual	8
Chapter 1 Introduction to Mellanox SB77X0 Systems	9
1.1 Overview	9
1.2 Speed and Switching	10
1.3 Management Interfaces and FRUs	10
1.4 Features	11
1.5 Certifications	11
1.6 Ordering Information	11
Chapter 2 Installation	12
2.1 Safety Warnings	12
2.2 Air Flow	13
2.3 Package Contents	14
2.4 Mounting Options	15
2.4.1 19" Systems Mounting - Static Rail-Kit	15
2.4.2 19" Systems Mounting- Telescopic Rail-Kit	20
2.5 Cable Installation	26
2.6 Initial Power On	27
2.7 Bring-Up of Managed Systems	28
2.7.1 Configuring Network Attributes	28
2.7.2 Remote Connection	31
2.8 FRU Replacements	32
2.8.1 Power Supply	32
2.8.2 Fans	33
Chapter 3 Software Management	35
3.1 InfiniBand Subnet Manager	35
3.2 Fabric Inspector (Diagnostics)	35
3.3 Upgrading Software (on Managed Systems)	36
3.4 Updating Firmware on Externally Managed Systems	36
3.4.1 Updating Firmware In-band (Typical)	36
Chapter 4 Interfaces	38
4.1 Supported Interfaces	38
4.1.1 Data Interfaces	38
4.1.2 Speed	38
4.1.3 RS232 (Console)	38
4.1.4 Management	39
4.1.5 USB	39
4.1.6 Reset Button	39
4.2 LEDs	40
4.2.1 LED Notifications	40

4.3	Inventory Pull-out Tab.....	46
Chapter 5	Troubleshooting.....	47
5.1	Troubleshooting Instructions.....	47
Chapter 6	Specifications.....	49
6.1	SB77X0 Series.....	49
Appendix A	Accessory and Replacement Parts.....	50
Appendix B	Thermal Threshold Definitions.....	51
Appendix C	Interface Specifications.....	52
C.1	QSFP Interface.....	52
C.2	RJ-45 CONSOLE and I ² C Interface.....	54
C.3	RJ45 to DB9 Harness Pinout.....	54
Appendix D	Disassembly and Disposal.....	55
D.1	Disassembly Procedure.....	55
D.2	Disposal.....	55
Appendix E	Safety Warnings (Multiple Languages).....	56
E.1	Nordic Countries Notices.....	56
E.2	Installation Safety Warnings (English).....	56
E.3	אזהרות בטיחות בהתקנה (עברית).....	59
E.4	安裝安全性警告 (Chinese).....	63
E.5	Avertissements de sécurité pour l'installation (French).....	66
E.6	Installation Sicherheitshinweise(German).....	69
E.7	Advertencias de seguridad de instalación (Spanish).....	73
E.8	Предупреждения по технике безопасности при установке (Russian)....	76
E.9	Avertismente privind siguranța la instalare (Romanian).....	79
E.10	Sigurnosna upozorenja za instaliranje (Croatian).....	83
E.11	Avvertenze di sicurezza per l'installazione (italiano).....	86
E.12	Montaj Güvenlik Uyarıları (Türkçe).....	90

List of Figures

Figure 1:	SB7700 and SB7790 Front Side View	10
Figure 2:	SB7700 Rear Side View	10
Figure 3:	SB7790 Rear Side View	10
Figure 4:	Air Flow Direction Marking - Power Side Inlet to Connector Side Outlet	14
Figure 5:	Air Flow Direction Marking - Connector Side Inlet to Power Side Outlet	14
Figure 6:	Rack Rail Kit Parts	16
Figure 7:	Installation Options	17
Figure 8:	Attaching the Rails to the Chassis	17
Figure 9:	Attaching the Brackets to the Chassis	18
Figure 10:	Attaching the Brackets to the Rack	18
Figure 11:	Sliding the Blades in the Rails	19
Figure 12:	Rack Rail Kit Parts	21
Figure 13:	Rails Separation	21
Figure 14:	Mounting the Outer Rails into the Rack	22
Figure 15:	Attaching the Inner Rails to the Chassis	23
Figure 16:	Securing the Chassis in the Inner Rails	23
Figure 17:	Sliding the Switch into the Rack	24
Figure 18:	Pulling the Unit Outwards	24
Figure 19:	Locking Mechanism	25
Figure 20:	Cable Orientation	26
Figure 21:	System Status LEDs 5 Minutes After Power On	27
Figure 22:	Two Power Inlets - Electric Caution Notifications	28
Figure 23:	PS Unit Pulled Out	33
Figure 24:	Fan Module Latches	34
Figure 25:	System Status LEDs - Front and Rear sides	41
Figure 26:	Fan Status LED - Front and Rear Sides	42
Figure 27:	Power Status LED	43
Figure 28:	Rear Side Panel	43
Figure 29:	Port LEDs	45
Figure 30:	Pull-out Tab	46
Figure 31:	QSFP Connector Male and Female Views	53
Figure 32:	RJ45 to DB9 Harness Pinout	54

List of Tables

Table 1:	Revision History Table	7
Table 2:	References	8
Table 3:	Speed and Switching Capabilities	10
Table 4:	Management Interfaces and FRUs	10
Table 5:	Ordering Part Numbers (OPNs)	11
Table 6:	Air Flow Color Legend	13
Table 7:	Installation Kit	15
Table 8:	Installation Kit	20
Table 9:	Serial Terminal Program Configuration	29
Table 10:	Configuration Wizard Session	29
Table 11:	Configuration Wizard Session - Static IP Configuration	30
Table 12:	LEDs Symbols	40
Table 13:	System Status LED Assignments	41
Table 14:	Fan Status Front LED Assignments	42
Table 15:	Fan Status Rear LED Assignments (One LED per Fan)	42
Table 16:	Power Supply Unit Status Front LED Assignments	43
Table 17:	Power Supply Unit Status Rear LED Assignments	44
Table 18:	Bad Port LED Assignments	44
Table 19:	Port LEDs in InfiniBand System Mode	45
Table 20:	Troubleshooting	47
Table 21:	SB77X0 Specifications	49
Table 22:	OPNs for Replacement Parts	50
Table 23:	RJ-45 CONSOLE and I ² C Pinout	54

Revision History

Table 1 - Revision History Table

Date	Revision	Description
July 2015	1.2	Changed document's title
June 2015	1.1	Added: <ul style="list-style-type: none">• Hebrew safety warnings Updated: <ul style="list-style-type: none">• Figure 1, "SB7700 and SB7790 Front Side View"• Table 21, "SB77X0 Specifications"
April 2015	1.0	Initial release

About this Manual

This manual describes the installation and basic use of the Mellanox InfiniBand EDR 1U switches.

Intended Audience

This manual is intended for IT managers and system administrators.

References

Table 2 - References

Document	Description
InfiniBand Architecture Specification, Volume 1, Release 1.2.1, and Volume 2, Release 1.3	The InfiniBand Architecture Specification that is provided by IBTA
MLNX-OS® User Manual	This document contains information regarding configuring and managing MLNX-OS software- see http://www.mellanox.com/page/mlnx_os .

Conventions

The following icons are used throughout this document to indicate information that is important to the user.



This icon makes recommendations to the user.



This icon indicates information that is helpful to the user.



This icon indicates a situation that can potentially cause damage to hardware or software.



This icon indicates a situation that can potentially cause personal injury.

1 Introduction to Mellanox SB77X0 Systems

1.1 Overview

The SB77X0 systems provide the highest performing fabric solution in a 1U form factor by delivering up to 7Tb/s of non-blocking bandwidth with sub 100ns port-to-port latency. These systems are the industry's most cost-effective building blocks for embedded systems and storage with a need for low port density systems. Whether looking at price-to-performance or energy-to-performance, these systems offer superior performance, power and space, reducing capital and operating expenses and providing the best return-on-investment.

Powerful servers combined with high-performance storage and applications that use increasingly complex computations are causing data bandwidth requirements to spiral upward. As servers are deployed with next generation processors, High-Performance Computing (HPC) environments and Enterprise Data Centers (EDC) need every last bit of bandwidth delivered with Mellanox's EDR InfiniBand systems.

Built with Mellanox's latest SwitchIB™ InfiniBand EDR 100Gb/s switch device, these stand-alone systems are an ideal choice for top-of-rack leaf connectivity or for building small to extremely large sized clusters. These systems enable efficient computing with features such as static routing, adaptive routing, and advanced congestion management. These features ensure the maximum effective fabric bandwidth by eliminating congestion.

SB7700, dual-core x86 CPU, comes with an onboard subnet manager, enabling simple, out-of-the-box fabric bring-up for up to 2048 nodes.

SB7700 switch runs the same MLNX-OS® software package as Mellanox FDR products to deliver complete chassis management of the firmware, power supplies, fans and ports.

Mellanox's edge systems can also be coupled with Mellanox's Unified Fabric Manager (UFM®) software for managing scale-out InfiniBand computing environments. UFM enables data center operators to efficiently provision, monitor and operate the modern data center fabric. UFM boosts application performance and ensures that the fabric is up and running at all times.

InfiniBand systems come as internally or externally managed. Internally managed systems include a CPU that runs the management software (MLNX-OS®) and management ports, which are used to transfer management traffic into the system. Externally managed systems come without the CPU and management ports, and are managed using firmware tools.

Figure 1: SB7700 and SB7790 Front Side View

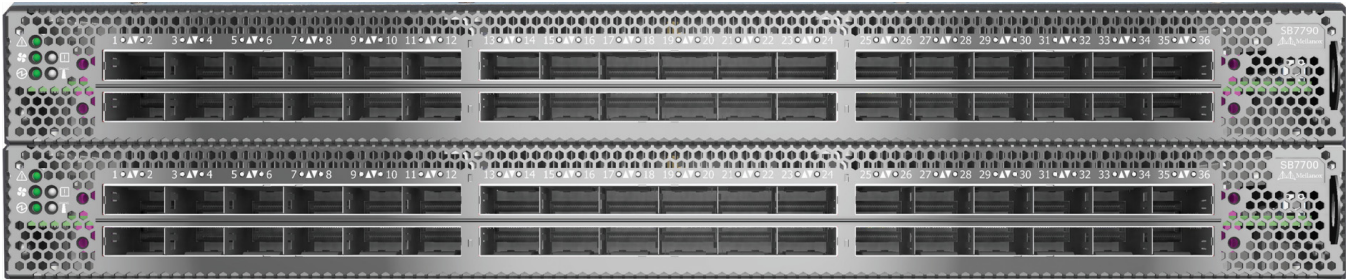

Figure 2: SB7700 Rear Side View



Figure 3: SB7790 Rear Side View



1.2 Speed and Switching

Table 3 describes maximum throughput and interface speed per system model.

Table 3 - Speed and Switching Capabilities

System Model	EDR 100Gb/s QSFP28 Interfaces	Max Throughput
SB7700	36	7.2Tb/s
SB7790	36	7.2Tb/s

1.3 Management Interfaces and FRUs

Table 4 lists the various management interfaces and available replacement parts per system model.

Table 4 - Management Interfaces and FRUs

System Model	USB	MGT (2 Ports)	I ² C*	Console*	Replaceable PSU	Replaceable Fan
SB7700	Rear	Rear	Rear	Rear	Yes	Yes
SB7790	NA	NA	Rear	NA	Yes	Yes

*The same connector is used for the I²C and the console interfaces.

1.4 Features

For a full feature list, please refer to the systems' product briefs:

http://www.mellanox.com/related-docs/prod_ib_switch_systems/pb_sb7700.pdf

http://www.mellanox.com/related-docs/prod_ib_switch_systems/pb_sb7790.pdf

1.5 Certifications

The list of certifications (such as EMC, Safety and others) per system for different regions of the world is located on the Mellanox website at:

http://www.mellanox.com/page/environmental_compliance

1.6 Ordering Information

the following table lists ordering information for the available systems. Please pay attention to the airflow direction when ordering your system. For more details, see “Air Flow” on page 13.

Table 5 - Ordering Part Numbers (OPNs)

System Model	OPN	Description
SB7700	MSB7700-ES2F	Switch-IB™ based EDR InfiniBand 1U Switch, 36 QSFP28 ports, 2 Power Supplies (AC), x86 dual core, standard depth, P2C airflow, Rail Kit, RoHS6
	MSB7700-ES2R	Switch-IB™ based EDR InfiniBand 1U Switch, 36 QSFP28 ports, 2 Power Supplies (AC), x86 dual core, standard depth, C2P airflow, Rail Kit, RoHS6
	MSB7700-EB2F	Switch-IB™ based EDR InfiniBand 1U Switch, 36 QSFP28 ports, 2 Power Supplies (AC), x86 dual core, short depth, P2C airflow, Rail Kit, RoHS6
SB7790	MSB7790-ES2F	Switch-IB™ based EDR InfiniBand 1U Switch, 36 QSFP28 ports, 2 Power Supplies (AC), unmanaged, standard depth, P2C airflow, Rail Kit, RoHS6
	MSB7790-EB2F	Switch-IB™ based EDR InfiniBand 1U Switch, 36 QSFP28 ports, 2 Power Supplies (AC), unmanaged, Short depth, P2C airflow, Rail Kit, RoHS6
	MSB7790-ES2R	Switch-IB™ based EDR InfiniBand 1U Switch, 36 QSFP28 ports, 2 Power Supplies (AC), unmanaged, standard depth, C2P airflow, Rail Kit, RoHS6

2 Installation

Installation and initialization of the system require attention to the normal mechanical, power, and thermal precautions for rack-mounted equipment.



The rack mounting holes conform to the EIA-310 standard for 19-inch racks. Take precautions to guarantee proper ventilation in order to maintain good airflow at ambient temperature.

➤ ***The installation procedure for the system involves the following phases:***

- Step 1.** Follow the safety warnings in Section 2.1 on page 12
- Step 2.** Pay attention to the air flow consideration within the system and rack - refer to “Air Flow” on page 13
- Step 3.** Make sure that none of the package contents is missing or damaged - see “Package Contents” on page 14
- Step 4.** Mount the system as suggested in “Mounting Options” on page 15
- Step 5.** Power on the system - refer to “Initial Power On” on page 27
- Step 6.** Perform system bring-up - see “Bring-Up of Managed Systems” on page 28

FRU replacements are described in Section 2.8 on page 32.

2.1 Safety Warnings

Prior to the installation, please review the safety warnings as follows:

- For Nordic Countries Notices, see Section E.1, “Nordic Countries Notices,” on page 56.
- For Safety Warnings in English, see Section E.2, “Installation Safety Warnings (English),” on page 56.
- For Safety Warnings in Hebrew, see Section E.3, “אזהרות בטיחות בהתקנה (עברית),” on page 59.
- For Safety Warnings in Chinese, see Section E.4 on page 63.
- For Safety Warnings in French, see Section E.5, “Avertissements de sécurité pour l'installation (French),” on page 66.
- For Safety Warnings in German, Section E.6, “Installation Sicherheitshinweise(German),” on page 69.
- For Safety Warnings in Spanish, see Section E.7, “Advertencias de seguridad de instalación (Spanish),” on page 73.
- For Safety Warnings in Russian, see Section E.8, “Предупреждения по технике безопасности при установке (Russian),” on page 76.
- For Safety Warnings in Romanian, see Section E.9, “Avertismente privind siguranța la instalare (Romanian),” on page 79.
- For Safety Warnings in Croatian, see Section E.10, “Sigurnosna upozorenja za instaliranje (Croatian),” on page 83.

- For Safety Warnings in Italian, see Section E.11, “Avvertenze di sicurezza per l’installazione (italiano),” on page 86.
- For Safety Warnings in Turkish see Section E.12, “Montaj Güvenlik Uyarıları (Türkçe),” on page 90.

2.2 Air Flow

Mellanox systems are offered with two air flow patterns:

- Connector (front) side inlet to power side outlet - marked with red power supplies/fans FRUs’ handles, as shown in Figure 4.
- Power (rear) side inlet to connector side outlet - marked with blue power supplies/fans FRUs’ handles, as shown in Figure 5.



All servers and systems in the same rack should be planned with the same airflow direction.

All FRU components need to have the same air flow direction. A mismatch in the air flow will affect the heat dissipation.

Table 6 provides an air flow color legend and respective OPN designations.

Table 6 - Air Flow Color Legend

Direction	OPN Designation	Description
	R	Connector side inlet to power side outlet. Red latches are placed on the power inlet side.
	F	Power side inlet to connector side outlet. Blue latches are placed on the power inlet side.

Figure 4: Air Flow Direction Marking - Power Side Inlet to Connector Side Outlet



Figure 5: Air Flow Direction Marking - Connector Side Inlet to Power Side Outlet



2.3 Package Contents

Before installing your new system, unpack it and check against the parts list below that all the parts have been sent. Check the parts for visible damage that may have occurred during shipping.

The SB77X0 package content is as follows:

- 1 x System
- 1 x Rail kit
- 2 x Power cables – Type C13-C14
- 1 x Harness: HAR000028 – Harness RS232 2M cable – DB9 to RJ-451 (in SB7700 models only)
- 2 x Cable retainers
- Quick Start Guide



If anything is damaged or missing, contact your sales representative at support@mellanox.com.

2.4 Mounting Options

By default, the system is sold with the Static Rail-kit described in Section 2.4.1. A Telescopic rail-kit can be purchased separately. For the Telescopic Rail-kit installation instructions, see Section 2.4.2.

2.4.1 19" Systems Mounting - Static Rail-Kit



At least two people are required to safely mount the system in the rack.

The following parts are included in the Static Rail kit (see Figure 6):

Table 7 - Installation Kit

Kit OPN	Rack Size and Rack Depth Range
MTEF-KIT-A	Short (17"-24") or Standard (24"-34")

- 2x Rack mount rails (A)
- 2x Rack mount brackets (B)
- 2x Rack mount blades (C)
- 8x M6 Standard cage nuts and 8x M6 Standard pan-head Phillips screws (D)
- 4x Phillips 100 DEG F.H TYPE-I ST.ST 6-32 X 1/4 screw with around patch (E).

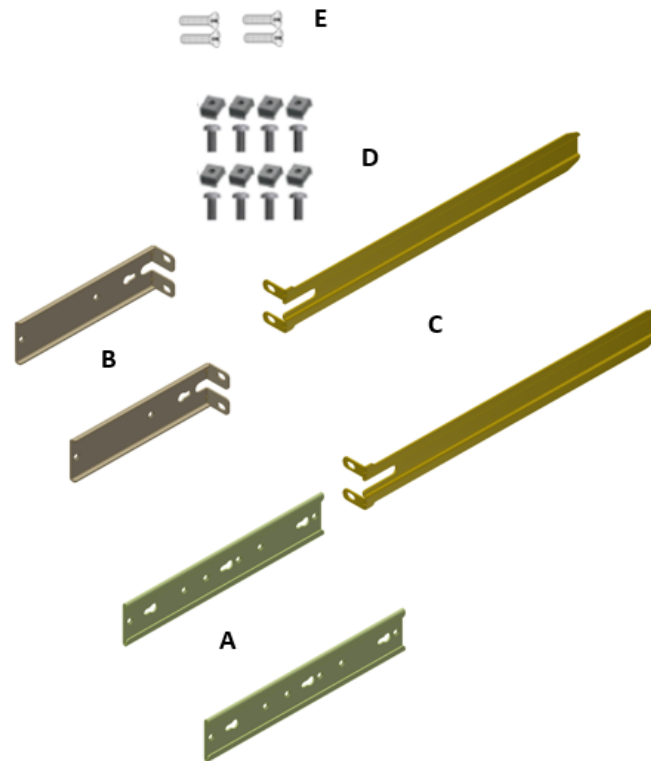
Figure 6: Rack Rail Kit Parts

➤ ***Planning the system's placement in the rack***

Before mounting the system to the rack, select the way you wish to place the system. Pay attention to the airflow within the rack cooling, connector and cabling options.

While planning how to place the system, consider the two installation options shown in Figure 7, and review the following points:

- Make sure the system air flow is compatible with your installation selection. It is important to keep the airflow within the rack in the same direction.
- Note that the part of the system to which you choose to attach the rails (the front panel direction, as demonstrated in Option 1 or the FRUs direction, as demonstrated in Option 2) will determine the system's adjustable side. The system's part to which the brackets are attached, will be adjacent to the cabinet.
- The FRU side is extractable. Mounting the rack brackets inverted to the FRU side (Option 2), will allow you to slide the FRUs, in and out.

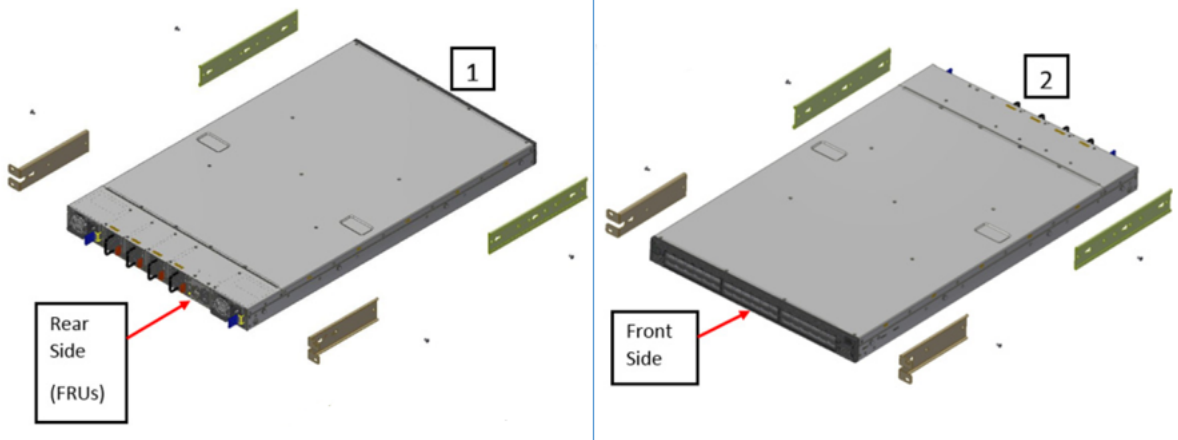
Figure 7: Installation Options

- Step 1.** Attach the left and right rack mount rails (A) to the switch, by gently pushing the switch chassis' pins through the slider key holes, until locking occurs. Secure the chassis in the rails, screwing 2 flat head Phillips screws (E) in the designated points. See Figure 8.

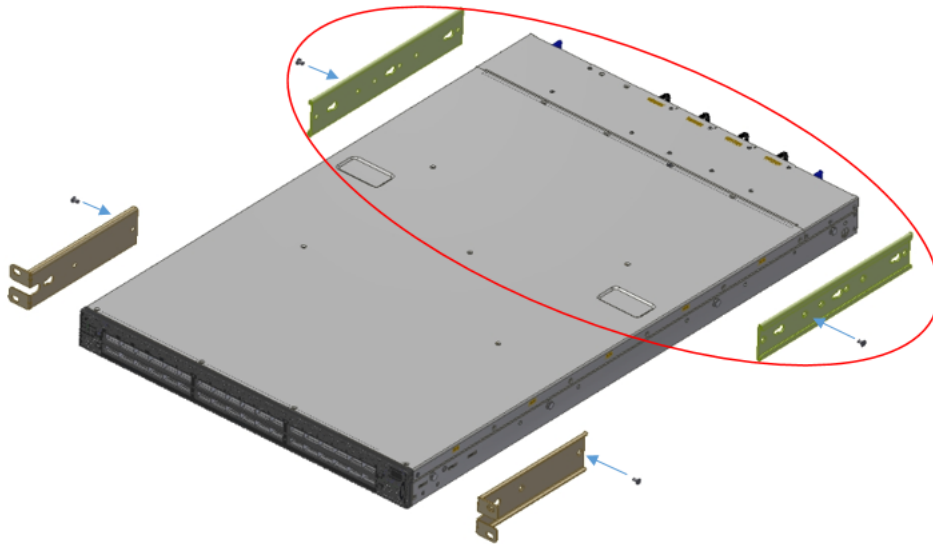
Figure 8: Attaching the Rails to the Chassis

- Step 2.** Attach the left and right rack mount brackets (B) to the switch, by gently pushing the switch chassis' pins through the slider key holes, until locking occurs. Secure the system in the brackets by screwing the remaining 2 flat head Phillips screws (E) in the designated points. See Figure 9.

Figure 9: Attaching the Brackets to the Chassis

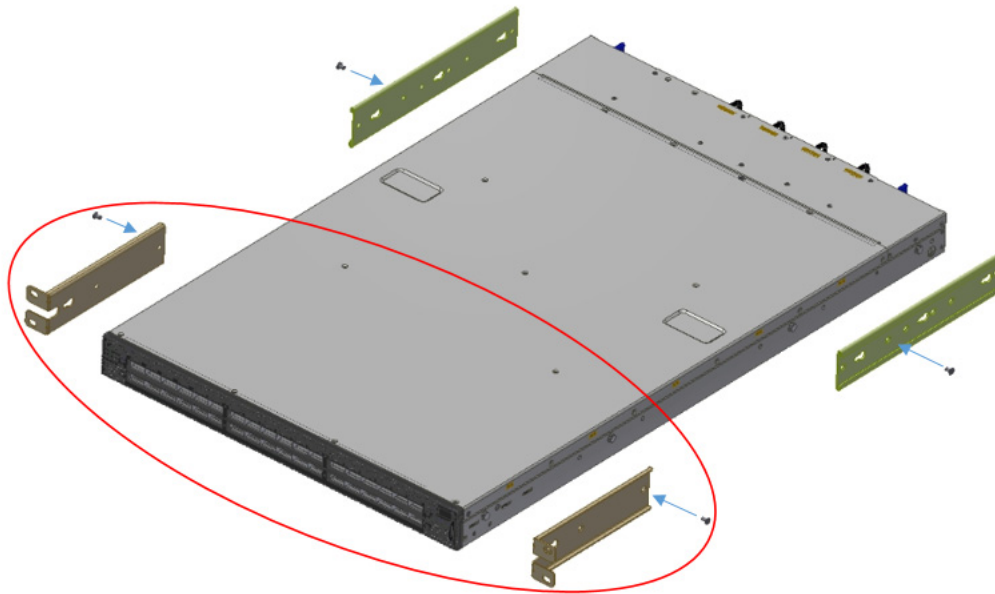

- Step 3.** Install 8 cage nuts in the desired 1U slots of the rack: 4 cage nuts in the non-extractable side and 4 cage nuts in the extractable side. Note that while each rack U (unit) consists of three holes, the cage nut should be installed vertically with its ears engaging the top and bottom holes only.

While your installation partner is supporting the system's weight, perform Steps 4, 5 and 6:

- Step 4.** Mount the system into the rack enclosure and attach the brackets installed on the system to the rack's posts. Secure the brackets to the rack's posts by inserting four M6 screws in the designated cage nuts. See Figure 10. Do not tighten the screws yet.
- Step 5.** Slide the two blades into the left and right rails, and adjust them to fit your rack's depth. Use four M6 screws (D) to fix the blades into the rack. Do not tighten the screws yet.

Figure 10: Attaching the Brackets to the Rack

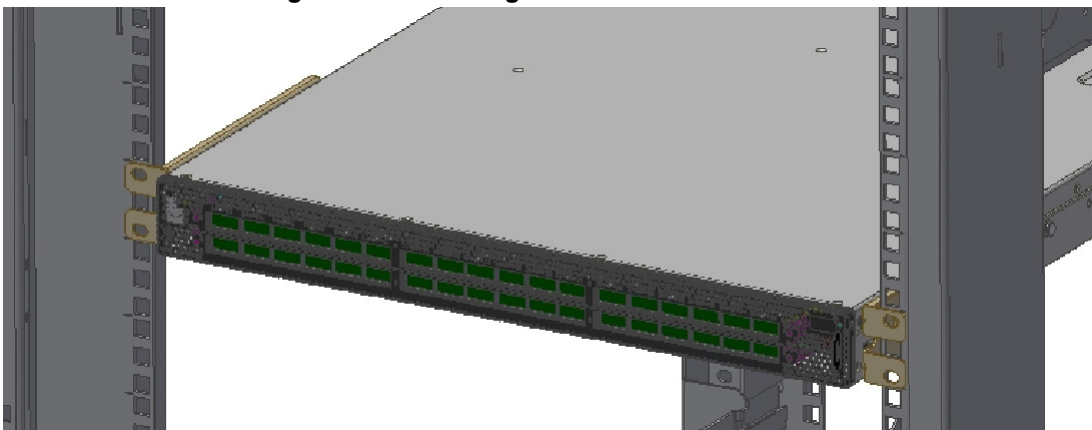
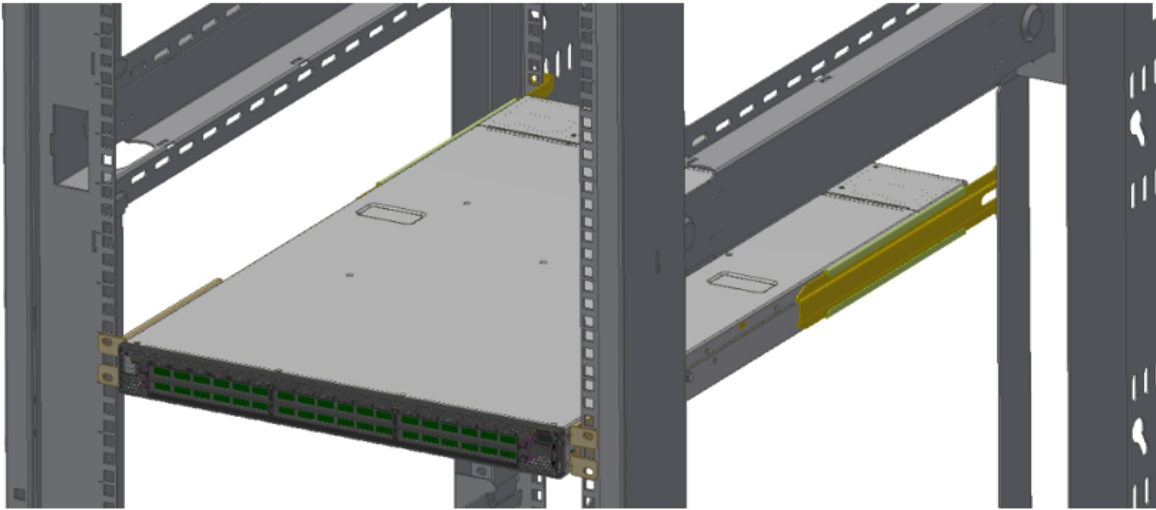

Figure 11: Sliding the Blades in the Rails



Step 6. Secure the system in the rack by tightening the 8 screws inserted in Step 4 and Step 5 with a torque of Min 2Nm.

2.4.1.1 Removing the System from the Rack

➤ *To remove a unit from the rack:*

Step 1. Turn off the system and disconnect it from peripherals and from the electrical outlet.

While your installation partner is supporting the system's weight:

Step 2. Loosen the screws attaching the brackets to the rack. Do not remove them yet.

Step 3. Loosen the screws attaching the blades to the rack, and pull the blades towards you, while your partner is holding the system.

Step 4. Extract the loosened screws from Step 2 and dismount the system from the rack.

Step 5. Remove the rails and brackets from the chassis by unscrewing 8 screws.

2.4.2 19" Systems Mounting- Telescopic Rail-Kit



Note: the Telescopic Rail-Kit is not included in the system's package, and can be purchased separately.

There are two installation kit options: standard and short. Standard depth systems should be mounted using the standard rail kit; short systems can be mounted using either of the rail kits.

The following parts are included in the rail kit rack (see Figure 12):

Table 8 - Installation Kit

Kit OPN	Rack Size	Rack Depth Range
MTEF-KIT-B	Short	17"-24"
MTEF-KIT-S	Standard (long)	24"-38"

- 1x Right inner rail (A)
- 1x Left inner rail (B)
- 2x Outer rails (C)
- 2x Outer rails (D)
- 10x M6 Standard cage nuts^{1 2} and 10x M6 Standard pan-head Phillips screws¹ (E)
- 2x Phillips 100 DEG F.H TYPE-I ST.ST 6-32 X 1/4 screw with around patch (F).

¹ Other threads are available by special order: M5, 10-32, 12-24

² G-type cage-nut is available by special order.



NOTE: The rails must be separated prior to the installation procedure. See Figure 13.

Figure 12: Rack Rail Kit Parts

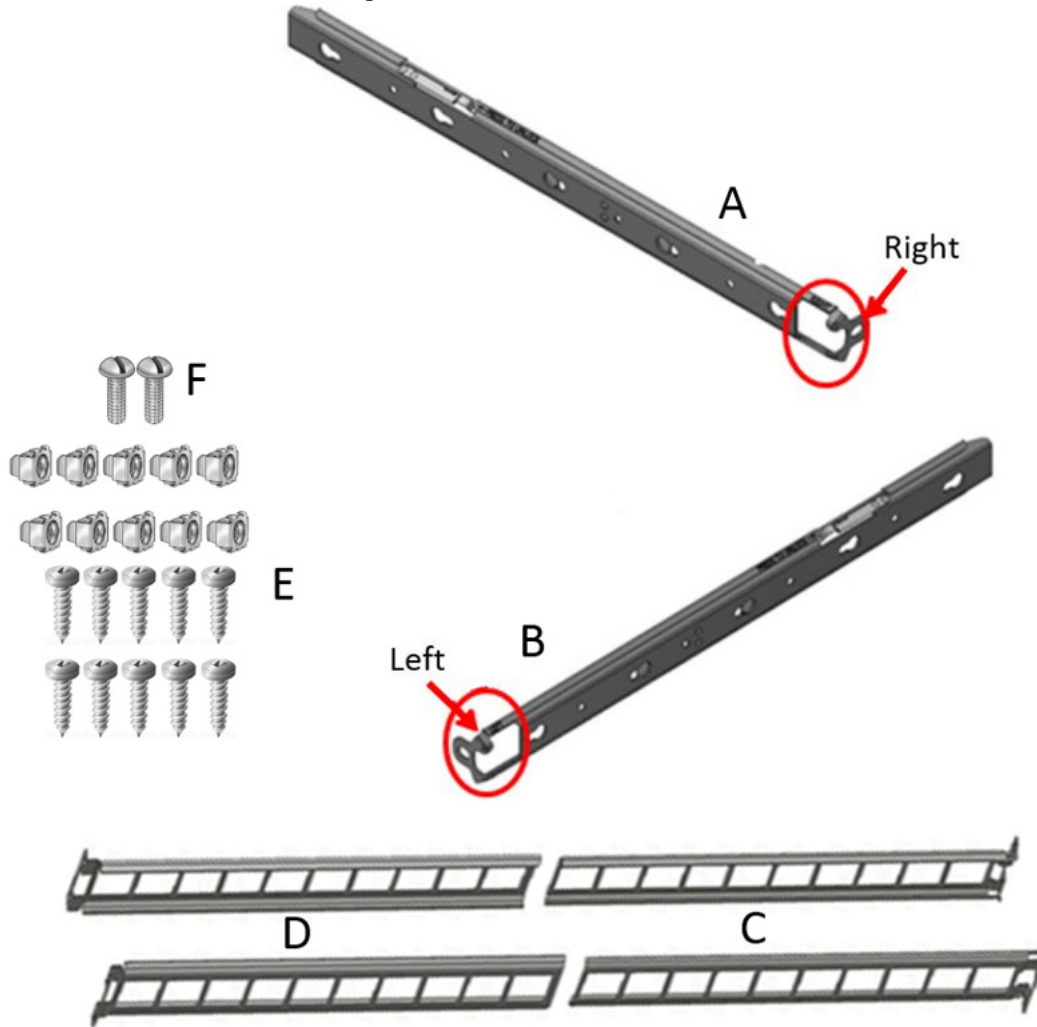
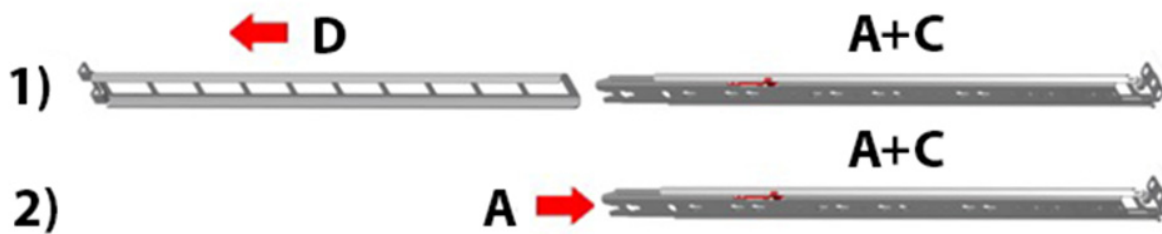

Figure 13: Rails Separation



➤ **To separate the rails:**

- Step 1.** Extend the rail assembly by pulling the extension outwards (D).
- Step 2.** Extract rail A from rail C by pushing it outside from the rear part of the assembly. by pushing it outside from the rear part of the assembly.
To allow complete separation of rail A from rail C, press the quick-release latch.

➤ ***Planning the system's placement in the rack***

Before mounting the system to the rack, select the way you wish to place the system. Pay attention to the airflow within the rack cooling, connector, and cabling options.

While planning how to place the system, review the following points:

- Make sure the system air flow is compatible with your installation selection. It is important to keep the airflow within the rack in the same direction.
- In case there are cables that cannot bend within the rack or in case more space is needed for cable bending radius, it is possible to recess the connector side or the FRU side by 3" or 4" (7.62 or 10.16cm) by optional placement of the system's rails.
- The FRU side is extractable. Mounting the sliding rail inverted to the system will allow you to slide the FRU side of the system, in and out.

- Step 1.** Install 10 cage nuts into the desired 1U slot of the rack: 4 cage nuts in the non-extractable side and 6 cage nuts in the extractable side.
- Step 2.** Mount both of the outer rails (C+D) into the rack (as illustrated in Figure 14), and use 8 standard pan-head screws (E) to fix them to the rack. Do not tighten the screws yet.
- Step 3.** If cable accommodation is required, rout the power cable and/or Eth cable through either of the outer rails.
- Step 4.** Secure the switch to the left and right inner rails (A+B), by gently pushing the switch chassis' pins through the slider key holes, until locking occurs.
- Step 5.** Secure the chassis in the inner rails screwing the 2 flat head Phillips screws (F) in the designated points.

Figure 14: Mounting the Outer Rails into the Rack



Figure 15: Attaching the Inner Rails to the Chassis

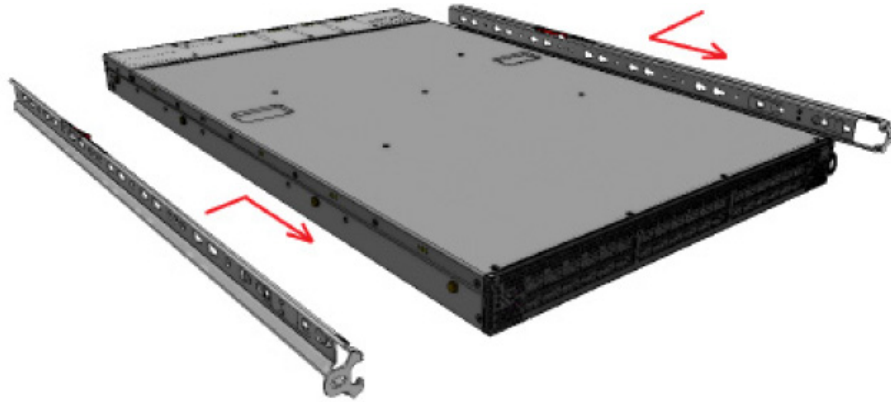
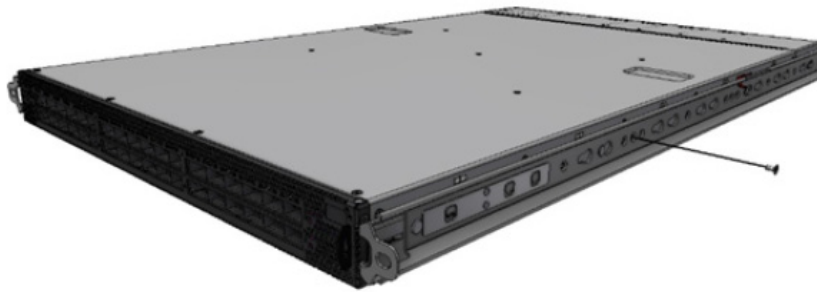
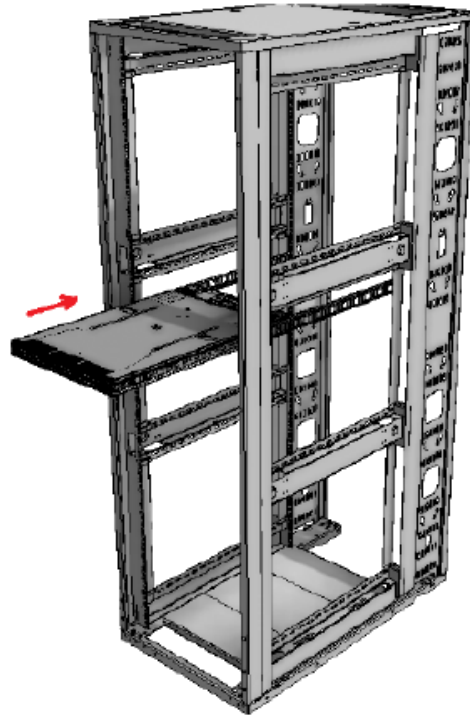

Figure 16: Securing the Chassis in the Inner Rails



- Step 6.** Slide the switch into the rack by carefully pushing the inner rails into the outer rails installed on the rack.
- Step 7.** When fully inserted, fix the switch by closing the remaining 2 screws in the middle and tightening the 8 screws inserted in Step 2 with a torque of Min 2Nm.

Figure 17: Sliding the Switch into the Rack



2.4.2.1 Removing the System from the Rack

➤ *To remove a unit from the rack:*

- Step 1.** Turn off the system and disconnect it from peripherals and from the electrical outlet.
- Step 2.** Unscrew the two M6 screws securing the front of the inner rails' ears to the outer rails and to the rack.
- Step 3.** Pull the unit out until braking is felt. For safety purposes, the locking mechanism will not allow a complete removal of the unit at this stage.
- Step 4.** Press on the locking spring (appears in red in Figure 19) on both sides simultaneously, and continue pulling the unit towards you until it is fully removed.

Figure 18: Pulling the Unit Outwards

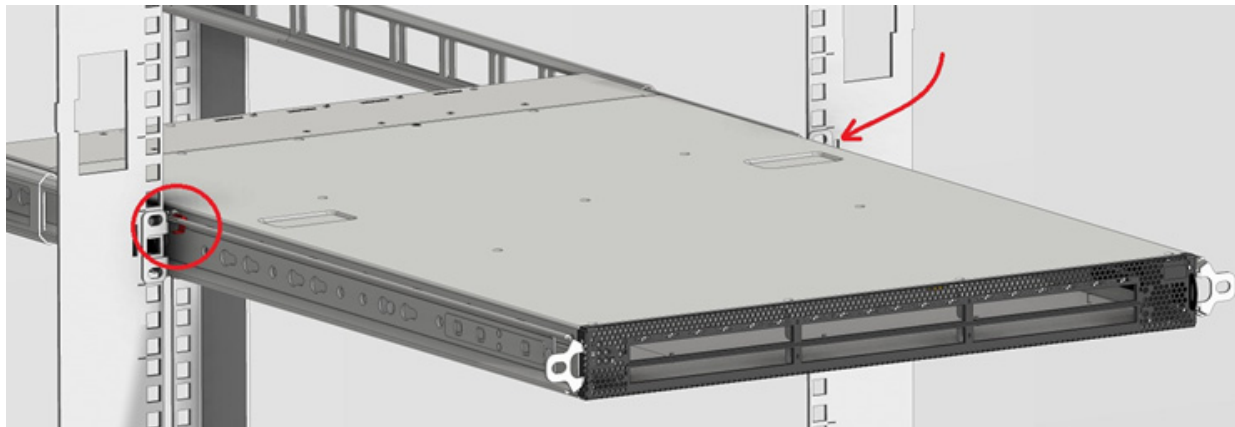
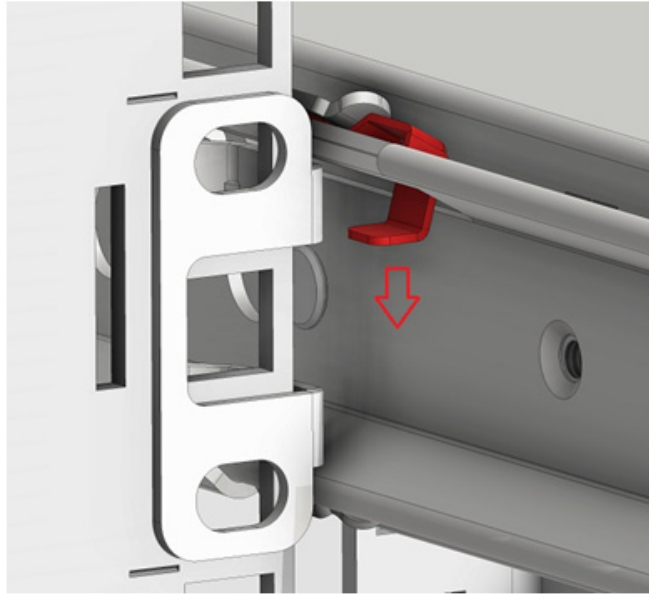

Figure 19: Locking Mechanism



2.5 Cable Installation

All cables can be inserted or removed with the unit powered on.

- To insert a cable, press the connector into the port receptacle until the connector is firmly seated. The LED indicator, corresponding to each data port, will light when the physical connection is established. When a logical connection is made the relevant port LED will turn on.
- To remove a cable, disengage the locks and slowly pull the connector away from the port receptacle. The LED indicator for that port will turn off when the cable is unseated.

For more information about port LEDs refer to Section 4.2.1.6, “Port LEDs,” on page 45.



Do not force the cable into the cage with more than 40 newtons / 9.0 pounds force / 4kg force. Greater insertion force may cause damage to the cable or the cage.

Figure 20: Cable Orientation

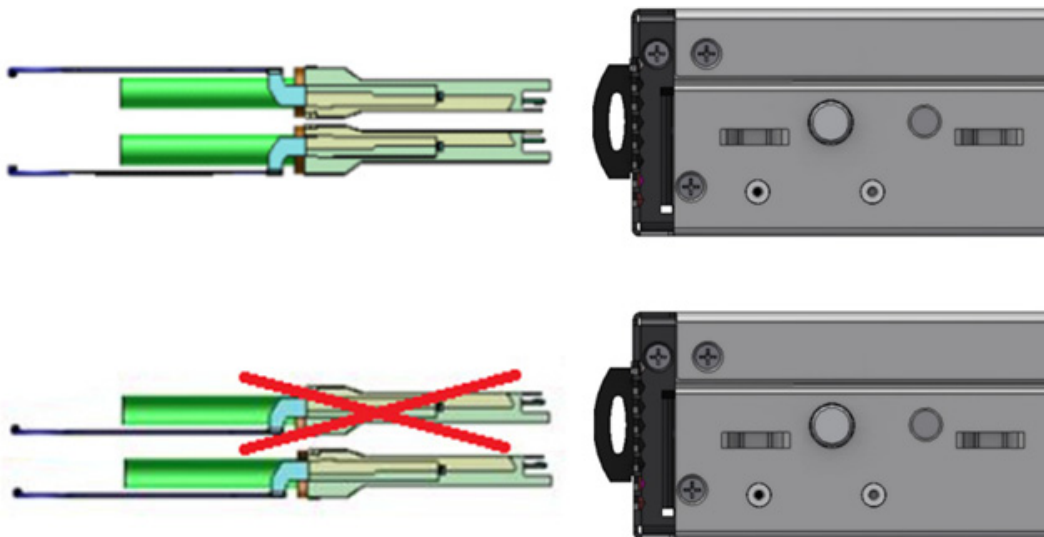

2.6 Initial Power On

The system's input voltage is auto-adjusting for 100 - 240VAC, 50-60Hz power connections. The power cords should be standard 3-wire AC power cords including a safety ground and rated for 15A or higher.



The system platform will automatically power on when AC power is applied. There is no power system. Check all boards, power supplies, and fan tray modules for proper insertion before plugging in a power cable.

- Step 1.** Plug in the first power cable.
- Step 2.** Plug in the second power cable.
- Step 3.** Wait for the system upload process.



It may take up to five minutes to turn on the system. If the System Status LED shows Red after five minutes, unplug the system and call your Mellanox representative for assistance.

- Step 4.** Check the System Status LEDs and confirm that all of the LEDs show status lights consistent with normal operation (initially flashing and then moving to a steady color) as shown in Figure 21 below. For more information, refer to "LEDs" on page 40.

Figure 21: System Status LEDs 5 Minutes After Power On





After inserting a power cable and confirming the green System Status LED light is on, make sure that the Fan Status LED shows green.

If the Fan Status LED is not green, unplug the power connection and check that the fan module is inserted properly and that the mating connector of the fan unit is free of any dirt and/or obstacles. If no obstacles were found and the problem persists, call your Mellanox representative for assistance.

Figure 22: Two Power Inlets - Electric Caution Notifications

CAUTION

Risk of electric shock and energy hazard. The two power supply units are independent.

Disconnect all power supplies to ensure a powered down state inside of the switch platform.

ACHTUNG

Gefahr des elektrischen Schocks. Entfernen des Netzsteckers eines Netzteils spannungsfrei. Um alle Einheiten spannungsfrei zu machen sind die Netzstecker aller Netzteile zu entfernen

ATTENTION

Risque de choc et de danger électriques. Le débranchement d'une seule alimentation stabilisée ne débranch uniquement qu'un module "Alimentation Stabilisée". Pour isoler complètement le module en cause, Il faut débrancher toutes les alimentations stabilisées.

電擊與能源危害的危險。

所有 PSU 均各自獨立。

將所有電源供應器斷電，確保交換器平台內部在電源關閉狀態。

2.7 Bring-Up of Managed Systems

2.7.1 Configuring Network Attributes

The procedures described in this chapter assume that you have already installed and powered-on the system according to the instructions in this document. Since the system comes with a pre-configured DHCP, you may find the explanation in Section 2.7.1.1 sufficient. In case a manual configuration is required, please refer to the instructions in Section 2.7.1.2.

2.7.1.1 Disable Dynamic Host Configuration Protocol (DHCP)

DHCP is used for automatic retrieval of management IP addresses..



If a user connects through SSH, runs the wizard and turns off DHCP, the connection is immediately terminated as the management interface loses its IP address.

```
<localhost># ssh admin@<ip-address>
Mellanox MLNX-OS Switch Management
Password:
Mellanox Switch
Mellanox configuration wizard
Do you want to use the wizard for initial configuration? yes
Step 1: Hostname? [my-switch]
Step 2: Use DHCP on mgmt0 interface? [yes] no
<localhost>#
```

In such case the serial connection should be used.

2.7.1.2 Manual Host Configuration

➤ *To perform initial configuration of the system:*

- Step 1.** Connect a host PC to the Console RJ45 (**IOIOI**) port of the system using the supplied harness cable (DB9 to RJ45). Make sure to connect to the Console RJ45 port and not to the (Ethernet) MGT port.
- Step 2.** Configure a serial terminal program (for example, HyperTerminal, minicom, or Tera Term) on your host PC with the settings described in [Table 9](#). Once you perform that, you should get the CLI prompt of the system.

Table 9 - Serial Terminal Program Configuration

Parameter	Setting
Baud Rate	115200
Data bits	8
Stop bits	1
Parity	None
Flow Control	None

- Step 3.** Login as *admin* and use *admin* as password. On the first login, the MLNX-OS configuration wizard will start.
- Step 4.** To configure network attributes and other initial parameters to the system, follow the configuration wizard as shown in [Table 10](#).

Table 10 - Configuration Wizard Session

Wizard Session Display	Comments
Mellanox configuration wizard Do you want to use the wizard for initial configuration? yes	You must perform this configuration the first time you operate the system or after resetting the system. Type 'y' and then press <Enter>.
Step 1: Hostname? [switch]	If you wish to accept the default hostname, press <Enter>. Otherwise, type a different hostname and press <Enter>.
Step 2: Use DHCP on mgmt0 interface? [no] yes	Perform this step to obtain an IP address for the system. (mgmt0 is the management port of the system). If you wish the DHCP server to assign the IP address, type 'yes' and press <Enter>. If you type 'no' (no DHCP), then you will be asked whether you wish to use the 'zeroconf' configuration or not. If you enter 'no' (no Zeroconf), you must enter a <i>static</i> IP, and the session will continue.
Step 3: Enable IPv6? [yes]	The management interface will be able to use IPv6 addresses.
Step 4: Enable IPv6 auto-config (SLAAC) on mgmt0 interface? [no]	This turns on auto-configuration of the IPv6 addresses. This is unsuitable for DHCPv6.

Table 10 - Configuration Wizard Session

Wizard Session Display	Comments
Step 5: Enable DHCPv6 on mgmt0 interface? [no]	To enable DHCPv6 on the MGMT0 interface.
Step 6: Admin password (Press <Enter> to leave unchanged)? <new_password> Step 6: Confirm admin password? <new_password>	To avoid illegal access to the machine, please type a password and then press <Enter>. Then confirm the password by re-entering it. Note that password characters are <i>not</i> printed.
You have entered the following information: <A summary of the configuration is now displayed.> To change an answer, enter the step number to return to or hit <enter> to save changes and exit. Choice: <Enter> Configuration changes saved.	The wizard displays a summary of your choices and then asks you to confirm the choices or to re-edit them. Either press <Enter> to save changes and exit, or enter the configuration step number that you wish to return to. Note: To re-run the configuration wizard, run the command “configuration jump-start” in Config mode.

The table below shows an example of static IP configuration for mgmt0 interface.

Table 11 - Configuration Wizard Session - Static IP Configuration

Wizard Session Display - Static IP Configuration (Example)
Mellanox configuration wizard Do you want to use the wizard for initial configuration? yes Step 1: Hostname? [] Step 2: Use DHCP on mgmt0 interface? [yes] no Step 3: Use zeroconf on mgmt0 interface? [no] Step 4: Primary IP address? [for example 192.168.10.4] 10.10.10.10 Mask length may not be zero if address is not zero (interface eth0) Step 5: Netmask? [0.0.0.0] 255.255.255.0 Step 6: Default gateway? [for example 192.168.10.1] 10.10.10.255 Step 7: Primary DNS server? Step 8: Domain name? Step 9: Enable IPv6? [yes] Step 10: Enable IPv6 autoconfig (SLAAC) on mgmt0 interface? [no] Step 11: Admin password (Enter to leave unchanged)? To change an answer, enter the step number to return to. Otherwise hit <enter> to save changes and exit. Choice: Configuration changes saved. To return to the wizard from the CLI, enter the “configuration jump-start” command from configure mode. Launching CLI... >

- Step 5.** Before attempting a remote (for example, SSH) connection to the system, check the mgmt0 interface configuration. Specifically, verify the existence of an IP address. To check the current mgmt0 configuration, enter the following commands:

```
switch (config) # show interfaces mgmt0
Interface mgmt0 status:
Comment:
Admin up:          yes
Link up:           yes
DHCP running:     yes
IP address:        10.209.28.50
Netmask:           255.255.255.0
IPv6 enabled:     yes
Autoconf enabled: no
Autoconf route:   yes
Autoconf privacy: no
DHCPv6 running:   no
IPv6 addresses:   1
IPv6 address:     fe80::202:c9ff:fe63:b55a/64
Speed:             1000Mb/s (auto)
Duplex:            full (auto)
Interface type:   ethernet
Interface source: physical
MTU:              1500
HW address:       00:02:C9:63:B5:5A

RX bytes:          968810197      TX bytes:          1172590194
RX packets:        10982099      TX packets:        10921755
RX mcast packets: 0              TX discards:       0
RX discards:       0              TX errors:          0
RX errors:         0              TX overruns:        0
RX overruns:       0              TX carrier:         0
RX frame:          0              TX collisions:      0
                                      TX queue len:      1000

switch (config) #
```

- Step 6.** You are advised to check the software version embedded in your system, using the command ‘show version’. you can continue and compare this version to the latest version that can be retrieved from Mellanox support site. To upgrade software, simply refer to MLNX-OS user manual.

2.7.2 Remote Connection

Once the network attributes are set, you can access the CLI via SSH or the WebUI via HTTP/HTTPS.

➤ *To access the CLI, perform the following steps:*

- Step 1.** Set up an Ethernet connection between the system and a local network machine using a standard RJ45 connector.
- Step 2.** Start a remote secured shell (SSH) using the command: “ssh -l <username> <IP_address>”,

```
# ssh -l <username> <ip address>
```

```
Mellanox MLNX-OS Switch Management
```

```
Password:
```

Step 3. Login as admin (default username is *admin*, password *admin*).

Step 4. Once you get the CLI prompt, you are ready to use the system.

For additional information about MLNX-OS, refer to MLNX-OS User Manual located on Mellanox support web.

2.8 FRU Replacements

2.8.1 Power Supply

Mellanox systems equipped with two replaceable power supply units work in a redundant configuration. Either unit may be extracted without bringing down the system.



Make sure that the power supply unit that you are NOT replacing is showing all green, for both the power supply unit and System Status LEDs.



Power supply units have directional air flows similar to the fan module. The fan module airflow must coincide with the airflow of all of the power supply units. If the power supply unit airflow direction is different from the fan module airflow direction, the system's internal temperature will be affected.

For power supply unit air flow direction, refer to Section 2.2 on page 13.

➤ ***To extract a power supply unit:***

Step 1. Remove the power cord from the power supply unit.

Step 2. Grasping the handle with your hand, push the latch release with your thumb while pulling the handle outward. As the power supply unit unseats, the power supply unit status LEDs will turn off.

Step 3. Remove the power supply unit.

Figure 23: PS Unit Pulled Out

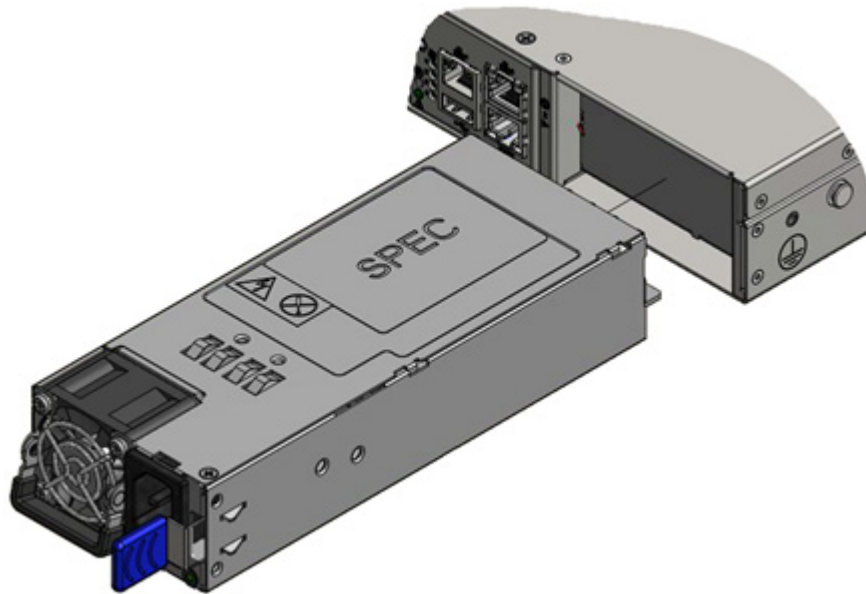

➤ **To insert a power supply unit:**

Step 1. Make sure the mating connector of the new unit is free of any dirt and/or obstacles.



Do not attempt to insert a power supply unit with a power cord connected to it.

Step 2. Insert the power supply unit by sliding it into the opening until a slight resistance is felt.

Step 3. Continue pressing the power supply unit until it seats completely. The latch will snap into place, confirming the proper installation.

Step 4. Insert the power cord into the supply connector.

Step 5. Insert the other end of the power cord into an outlet of the correct voltage.



The green power supply unit indicator should light. If not, repeat the whole procedure to extract the power supply unit and re-insert it.

2.8.2 Fans

The system can fully operate if one fan FRU is dysfunctional or missing. Failure of more than one fan is not supported..



Make sure that the fans have the air flow that matches the model number. An air flow opposite to the system design will cause the system to operate at a higher (less than optimal) temperature.

For power supply unit air flow direction, refer to Section 2.2 on page 13

➤ **To extract a Fan Unit:**

- Step 1.** Grasping the handle with your hand, push the latch release with your thumb while pulling the handle outward. As the fan unit unseats, the fan unit status LEDs will turn off.
- Step 2.** Remove the fan unit.

Figure 24: Fan Module Latches



To remove or replace a fan unit, gently pull out its black handle while pushing the latch release with your thumb.

➤ **To insert a FAN Unit:**

- Step 1.** Make sure the mating connector of the new unit is free of any dirt and/or obstacles.
- Step 2.** Insert the fan unit by sliding it into the opening until slight resistance is felt. Continue pressing the fan unit until it seats completely.



The green Fan Status LED should light. If not, extract the fan unit and reinsert it. After two unsuccessful attempts to install the fan unit, power off the system before attempting any system debug.

3 Software Management

Managed systems come with an embedded management CPU card that runs MLNX-OS® management software.

The MLNX-OS systems management package and related documentation can be downloaded via the product page:

http://www.mellanox.com/page/mlnx_os.

3.1 InfiniBand Subnet Manager

The InfiniBand Subnet Manager (SM) is a centralized entity running in the system. The SM applies network traffic related configurations such as QoS, routing, partitioning to the fabric devices. You can view and configure the Subnet Manager parameters via the CLI/WebUI. Each subnet needs one subnet manager to discover, activate and manage the subnet.

Each network requires a Subnet Manager to be running in either the system itself (system based) or on one of the nodes which is connected to the fabric (host based).



No more than two subnet managers are recommended for any single fabric.

The InfiniBand Subnet Manager running on the system supports up to 2048 nodes. If the fabric includes more than 2048 nodes, you may need to purchase Mellanox's Unified Fabric Manager (UFM®) software package.

Each subnet needs one subnet manager to discover, activate and manage the subnet.

Each network requires a Subnet Manager to be running in either the system itself (system based) or on one of the nodes which is connected to the fabric (host based).

The subnet manager (OpenSM) assigns Local IDentifiers (LIDs) to each port connected to the fabric, and develops a routing table based on the assigned LIDs.

A typical installation using the OFED package will run the OpenSM subnet manager at system start up after the drivers are loaded. This automatic OpenSM is resident in memory, and sweeps the fabric approximately every 5 seconds for new adapters to add to the subnet routing tables.

3.2 Fabric Inspector (Diagnostics)

Fabric Inspector is a plug & play licensed software within MLNX-OS® displaying and filtering all identified systems and nodes within the fabric.

Fabric Inspector includes a complete set of InfiniBand tools for fabric wide diagnostics to check node-node and node-switch connectivity and to verify routes within the fabric.

Advanced filtering allows creating filtering rules on a system wide basis, between nodes or port connections based on traffic patterns and user assigned system names (GUIDs).

3.3 Upgrading Software (on Managed Systems)

Software and firmware updates are available from the Mellanox Support website. Check that your current revision is the same one that is on the Mellanox website. If not upgrade your software. Copy the update to a known location on a Remote server within the user's LAN.

Use the CLI or the GUI in order to perform software upgrades. For further information please refer to the MLNX-OS Software User Manual section Upgrading MLNX-OS® Software.

Be sure to read and follow all of the instructions regarding the updating of the software on your system.

Managed systems do not require Firmware updating. Firmware updating is done through the MLNX-OS management software. The system comes standard with a management software module for system management called Mellanox Operating System (MLNX-OS). MLNX-OS® is installed on all SwitchIB® based managed systems. MLNX-OS® includes a CLI, WebUI, SNMP, system management software and IB management software (OpenSM).



The Ethernet ports for remote management connect to Ethernet systems. These systems must be configured to 100Mb/1 Gb auto-negotiation.

3.4 Updating Firmware on Externally Managed Systems

There are two methods to update system firmware:

1. (Typical) In-band via a switch network port across a cable connecting the server to the switch port.
2. (Non-typical) Via the I²C port of the switch using a Mellanox MTUSB-1 device connecting to a server's USB port on the one end and to the I²C port of the switch on the other.

Firmware updates should normally be conducted in-band. The use of the MTUSB-1 device is intended for cases of debug or firmware corruption and should be conducted by Mellanox Fields or Support engineers, or by trained users at the customer's site.

Both types of updated require the installation of Mellanox Firmware Tools (MFT) package. The MFT package and user manual are available for download under http://www.mellanox.com/page/management_tools. Please select the package that suits your operating system.

In order to obtain information regarding the externally managed system, you must download the Mellanox MFT tools from http://www.mellanox.com/page/management_tools.

Select and download the release that matches your system. Follow the instructions in the User Manual http://www.mellanox.com/pdf/MFT/MFT_user_manual.pdf to get the tools.

3.4.1 Updating Firmware In-band (Typical)

Check the currently programmed firmware on the system and compare it to the latest firmware available under http://www.mellanox.com/page/firmware_download (check under SwitchIB® Switch Systems).

➤ ***In order to obtain the firmware version of the externally managed system:***

- Step 1.** Obtain the LID of the target system. The following instructions use one of the utilities provided by the installed MFT package. (Other methods are described in the MFT User Manual.) by performing the following:

- Step a. Mark the GUID printed on the inventory pull-out tab of the system.
- Step b. Run the command `ibnetdiscover` and search for the row starting with the word "Switch" and indicates the GUID of the system.
- Step c. Mark the displayed LID on that row (a decimal number).

Step 2. Run the following command from a host

```
flint -d lid-[number] -i <image> b
```

For further information, please refer to MFT User Manual: http://www.mellanox.com/pdf/MFT/MFT_user_manual.pdf

4 Interfaces

4.1 Supported Interfaces

The systems support the following interfaces:

- Data interfaces - InfiniBand
- 100/1000 MbE RJ45 management interface(s)
- USB
- RS232 Console port
- I²C interface
- Reset button
- Status and Port LEDs

In order to review the full configuration options matrix, refer to Table 4, “Management Interfaces and FRUs”.

4.1.1 Data Interfaces

The data interfaces use QSFP28 connectors. The full list of interfaces per system is provided in Table 3, “Speed and Switching Capabilities,” on page 10.

Each QSFP28 port can be connected with QSFP28 cable or connector for 40/56Gb/s/100Gb/s.

The system offers High Power class 4 transceivers support in all ports.

4.1.2 Speed

InfiniBand speed is auto-adjusted by the InfiniBand protocol.

Mellanox systems support QDR/FDR10/FDR/EDR InfiniBand.

- FDR10 is a non-standard InfiniBand data rate, where each lane of a 4X port runs a bit rate of 10.3125 Gb/s with a 64b/66b encoding, resulting in an effective bandwidth of 40 Gb/s. FDR10 supports 20% more bandwidth over QDR due to better encoding rate.
- FDR is an InfiniBand data rate, where each lane of a 4X port runs a bit rate of 14.0625 Gb/s with 64b/66b encoding, resulting in an effective bandwidth of 56.25 Gb/s.
- EDR is an InfiniBand data rate, where each lane of a 4X port runs a bit rate of 25 Gb/s with 64b/66b encoding, resulting in an effective bandwidth of 100 Gb/s.

4.1.3 RS232 (Console)



This interface is not found in externally managed systems.

The port labeled “Console” **IOIOI** is an RS232 serial port on the back side of the chassis that is used for initial configuration and debugging. Upon first installation of the system, you need to connect a PC to this interface and configure network parameters for remote connections. Refer to Section 2.7.1 to view the full procedure.

4.1.4 Management

The two RJ45 Ethernet ports labeled  provide access for remote management. The management ports are configured with auto-negotiation capabilities by default (100MbE to 1000GbE). The management ports' network attributes (such as IP Address) need to be pre-configured via the RS232 serial console port or by DHCP before use. Refer to Section 2.7.1 to view the full procedure.



Make sure you use only FCC compliant Ethernet cables.

4.1.5 USB

The USB interface is USB 2.0 compliant and can be used by MLNX-OS software to connect to an external disk for software upgrade or file management. The connector comes in a standard USB shape.

To view the full matrix of the USB configuration options, refer to Table 4, “Management Interfaces and FRUs”.



USB 1.0 is not supported.



Do NOT use excessive force when inserting or extracting the USB disk from the connector.

4.1.6 Reset Button

The reset button is located on the rear side of the system next to the fan status LEDs. This reset button requires a tool to be pressed.



DO NOT use a sharp pointed object such as a needle or a push pin for pressing the Reset button. Use a flat object to push the reset button.





- To reset the system and the CPU of its management board, push the Reset button and keep it pressed for up to 15 seconds.
- To reset the system, the CPU of its management board and the “admin” password, push the Reset button and keep it pressed for at least 15 seconds. You will then be able to enter without a password and set a new password for the user “*admin*”.
In the externally managed systems the Reset button resets the device.

4.2 LEDs

4.2.1 LED Notifications

The system’s LEDs are an important tool for hardware event notification and troubleshooting.

Table 12 - LEDs Symbols

Symbol	Name	Description	Normal Conditions
	System Status LED	Shows the health of the system	Green/Flashing green when booting
	Fan Status LED	Shows the health of the fans	Green
	Power supply units LED	Shows the health of the power supply units	Green
	Bad Port LED	Lights up when a symbol error is detected on one of the ports.	Off
* 	*Unit Identifier LED	Beacon LED, lights up on command through the CLI	Off or blue when identifying port

*This function is currently disabled.

4.2.1.1 System Status LED

Figure 25: System Status LEDs - Front and Rear sides



Both of the System Status LEDs (front and back) supply identical information.



It may take up to five minutes to turn on the system. If the System Status LED shows red after five minutes, unplug the system and call your Mellanox representative for assistance.

Table 13 - System Status LED Assignments

LED Behavior	Description	Action Required
Solid Green	The system is up and running normally	N/A
Flashing Green	The system is booting up. This assignment is valid on managed systems only.	Wait up to five minutes for the end of the booting process.
Solid Red	An error has occurred. For example, corrupted firmware, system is overheated etc.	If the System Status LED shows Red five minutes after starting the system, unplug the system and call your Mellanox representative for assistance.

4.2.1.2 Fan Status LED

Figure 26: Fan Status LED - Front and Rear Sides

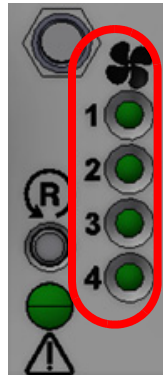

Both of these LEDs in the red circles show the fans' status.



Table 14 - Fan Status Front LED Assignments

LED Behavior	Description	Action Required
Solid Green	All fans are up and running.	N/A
Solid Red	Error, one or more fans are missing or not operating properly.	The faulty FRUs should be replaced.
Off	System boot	N/A

Table 15 - Fan Status Rear LED Assignments (One LED per Fan)

LED Behavior	Description	Action Required
Solid Green	Specific fan unit is operating	N/A
Solid Red	A specific fan unit is missing or not operating properly.	The fan unit should be replaced.
Off	System boot	N/A



Risk of Electric Shock!

With the fan module removed, power pins are accessible within the module cavity. DO NOT insert tools or body parts into the fan module cavity.

4.2.1.3 Power Supply Status LEDs

Figure 27: Power Status LED



There are two power supply inlets in the system (for redundancy). The system can operate with only one power supply connected. In case the power supply is an FRU, a second power supply unit can be added to support hot-swap ability. Each power supply unit has a single 2 color LED on the right side of the unit, that indicates the status of the unit.

Figure 28: Rear Side Panel

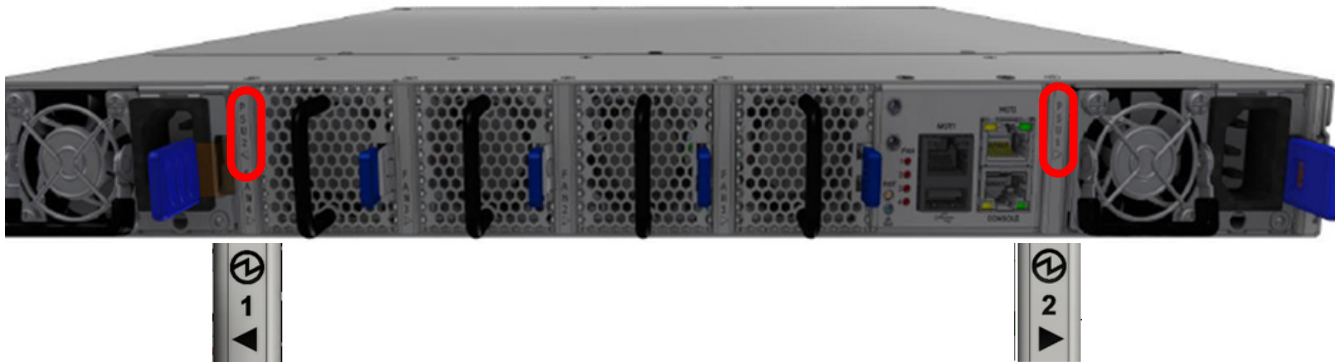

The primary power supply (PS) unit is located on the left side and the secondary unit is located on the right side.

Table 16 - Power Supply Unit Status Front LED Assignments

LED Behavior	Description	Action Required
Solid Green	All plugged (one or two) power supplies are running normally.	N/A
Solid Red	One or both of the power supplies are not operational or not powered up/ the AC power cable is disconnected	Make sure the AC cable is plugged in and active. If the problem resumes, the FRUs might be faulty, and should then be replaced.
Off	N/A	N/A

The power supply status LEDs on the rear side of the system are located on the PSUs themselves. Each PSU has one LED of its own.

Table 17 - Power Supply Unit Status Rear LED Assignments

LED Behavior	Description	Action Required
Solid Green	The PSU is running normally.	N/A
Flashing Green 1Hz	AC present / Only 12VSB on (PSU off) or PSU in Smart-on state.	Call your Mellanox representative for assistance.
Amber	AC cord unplugged or AC power lost while the second power supply still has AC input power.	Plug in the AC cord of the faulty PSU
	PS failure (including voltage out of range and power cord disconnected).	Check voltage. If OK, call your Mellanox representative for assistance.
Flashing Amber	Power supply warning events where the power supply continues to operate; high temp, high power, high current, slow fan.	Call your Mellanox representative for assistance.
Off	No AC power to all power supplies.	Call your Mellanox representative for assistance.

4.2.1.4 UID LED

The UID LED is a debug feature, that the user can use to find a particular system within a cluster by turning on the UID blue LED. This is a future feature that is not yet available.

4.2.1.5 Bad Port LED

The Bad Port LED indicator is used to indicate symbol errors in one or more system ports.

Table 18 shows the bad port status LED assignment.

Table 18 - Bad Port LED Assignments

LED Configuration	Description	Action Required
Off	No symbol errors have been received in last few seconds (normal condition)	N/A
Flashing Amber	Error, one or more ports have received symbol errors. Possible causes are: <ul style="list-style-type: none"> • Bad cable • Bad connection • Bad connector 	Check symbol error counters on the system UI to identify the ports. Replace the cable on these ports.

4.2.1.6 Port LEDs

Figure 29: Port LEDs

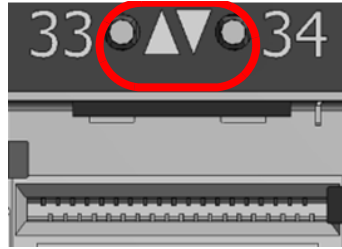

Table 19 - Port LEDs in InfiniBand System Mode

LED Behavior	Description	Action Required
Off	Link is down.	Check the cable
Solid Green	Logical link is up.	N/A
Flashing Green	Data activity flashing speed is proportional to data transfer speed.	N/A
Solid Amber	Link is up.	Wait for the Logical link to raise. Check that the SM is up.
Flashing Red	A problem with the physical link.	Check that the SM is up.

In InfiniBand system mode, the LED indicator, corresponding to each data port, will light orange when the physical connection is established (that is, when the unit is powered on and a cable is plugged into the port with the other end of the connector plugged into a functioning port). When a logical connection is made the LED will change to green. When data is being transferred the light will blink green.

4.3 Inventory Pull-out Tab

The system's inventory parameters (such as serial number, part number and GUID address) can be extracted from the inventory pull-out tab on the lower right side of the front panel.

Figure 30: Pull-out Tab



5 Troubleshooting

5.1 Troubleshooting Instructions

Table 20 - Troubleshooting

Problem Indicator	Symptoms	Corrective Measures
LEDs	System Status LED is blinking for more than 5 minutes	This state means that the MLNX-OS software did not boot properly and only firmware is running. To overcome it, connect to the system via the console port, and check the software status. You might need to contact an FAE if the MLNX-OS software did not load properly
	System Status LED is Red	This state can indicate a number of problems: <ul style="list-style-type: none"> • Critical system fault (CPU error, bad firmware) • Over Temperature To overcome it: <ul style="list-style-type: none"> • Check Environmental conditions (room temperature)
	Fan Status LED is Red	This state is indicative of a problem with the FAN. <ul style="list-style-type: none"> • Check that the FAN is fully inserted and nothing blocks the airflow. • Replace the FAN FRU if needed.
	Front PSU Status LED is Red	This state is indicative of a problem with the PSU. <ul style="list-style-type: none"> • Check/replace the power cable. • Replace the PSU if needed.
	The activity LED does not light up (InfiniBand):	Make sure that there is an SM running in the fabric.

Table 20 - Troubleshooting

Problem Indicator	Symptoms	Corrective Measures
System boot failure	The last software upgrade failed on x86 based systems	<ul style="list-style-type: none"> • Connect the RS232 connector (CONSOLE) to a laptop. • Push the system's reset button. • Press the ArrowUp or ArrowDown key during the system boot. GRUB menu will appear. For example: <pre> Default image: 'SX_X86_64 SX_3.4.0008 2014-11-10 20:07:51 x86_64' Press enter to boot this image, or any other key for boot menu Booting default image in 3 seconds. Boot Menu ----- 0: SX_X86_64 SX_3.4.0008 2014-11-10 20:07:51 x86_64 1: SX_X86_64 SX_3.4.0007 2014-10-23 17:27:34 x86_64 ----- Use the * and * keys to select which entry is highlighted. Press enter to boot the selected image or 'p' to enter a password to unlock the next set of features. Highlighted entry is 0: " </pre> <ul style="list-style-type: none"> • Select previous image to boot by pressing an arrow key and choosing the appropriate image.

6 Specifications

6.1 SB77X0 Series

Table 21 - SB77X0 Specifications

Feature	Value
Mechanical	Size: Short - 1.716" (H) x 16.85" (W) x 16.8" (D), 43.6mm (H) x 428mm (W) x 428.9 mm (D) Standard - 1.716" (H) x 16.85" (W) x 24.75" (D), 43.6mm (H) x 428mm (W) x 722.3 mm (D) Mounting: 19" Rack mount
	Weight: Long: 1 PSU: 11.11 2 PSUs: 11.978 Short: 1 PSU: 7.85 2 PSUs: 8.63kg
	Speed: 40, 56, 100Gb/s per port
	Connector cage: 36 QSFP28
	Air flow: 100 CFM
Environmental	Temperature: Operational: 0° to 45°C Non-Operational: -40° to 70°C
	Relative Humidity: Operational: 10% - 85% non-condensing Non-Operational: 10% - 90% non-condensing
	Altitude: Operational: 3050m Non-Operational: 3050m
Power	Input Voltage: 100 - 240 VAC 50-60Hz
	Global Power Consumption - SB7700: Typical with passive cables: 218W Typical with optical cables (LR4 and SR4): 338W Max with passive cables: 281W Max with optical cables (LR4 and SR4): 437W Global Power Consumption - SB7790: Typical with passive cables: 205W Typical with optical cables (LR4 and SR4): 324W Max with passive cables: 232W Max with optical cables (LR4 and SR4): 387W
Main Devices	CPU (in SB7700 only): Intel Celeron 1047UE (x86)
	Switch: Mellanox Switch-IB™
Switching	Capacity: 7.2Tb/s

Appendix A: Accessory and Replacement Parts

Table 22 - OPNs for Replacement Parts

OPN	Part Description
MTEF-KIT-A	Rack installation kit for 1U systems to be mounted into short or standard depth racks
MTEF-KIT-B	Telescopic Rack installation kit for standard depth 1U systems to be mounted into standard depth racks
MTEF-KIT-S	Telescopic Rack installation kit for standard depth 1U systems to be mounted into standard depth racks
MTEF-PSF-AC-A	460W AC Power Supply w/ rear to front air flow
MTEF-PSR-AC-A	460W AC Power Supply w/ front to rear air flow
HAR000028	Harness RS232 2M cable – DB9 to RJ-45 (for managed switches only)
ACC000501	Mellanox® 1U edge switch black power cord, 250V, 10A, 1830MM and C14 TO C13
MTEF-FANF-A	Fan module w/rear to front airflow fan for SB77X0 switch systems
MTEF-FANR-A	Fan module w/front to rear airflow fan for SB77X0 switch systems

Appendix B: Thermal Threshold Definitions

There are three thermal threshold definitions for the SwitchIB® switch device which impact the overall switch system operation state: Warning, Critical and Emergency.

1.Warning – 105°C

On managed systems only: When the device crosses the 100°C threshold, a Warning Threshold message will be issued by the MLNX-OS management SW, indicating to system administration that the switch has crossed the Warning threshold.

Note that this temperature threshold does not require nor lead to any action by hardware (such as switch shutdown).

2.Critical – 120°C

When the SwitchIB® device crosses this temperature, the firmware will automatically shut down the device.

3.Emergency – 130°C

In case the firmware fails to shut down the SwitchIB® device upon crossing the Critical threshold, the device will auto-shutdown upon crossing the Emergency (130°C) threshold.

Appendix C: Interface Specifications

C.1 QSFP Interface

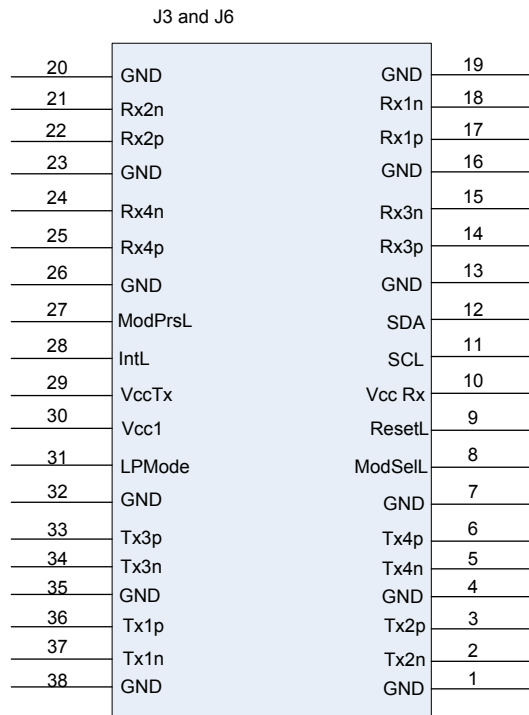

Connector Pin Number	Connector Pin Name	Signal Description
1	GND	Ground
2	Tx2n	Transmitter Inverted Data Input
3	Tx2p	Transmitter Non-Inverted Data Input
4	GND	Ground
5	Tx4n	Transmitter Inverted Data Input
6	Tx4p	Transmitter Non-Inverted Data Input
7	GND	Ground
8	ModSelL	Module Select
9	ResetL	Module Reset
10	Vcc Rx	+3.3 V Power supply receiver
11	SCL	2-wire serial interface clock
12	SDA	2-wire serial interface data
13	GND	Ground
14	Rx3p	Receiver Non-Inverted Data Output
15	Rx3n	Receiver Inverted Data Output
16	GND	Ground
17	Rx1p	Receiver Non-Inverted Data Output
18	Rx1n	Receiver Inverted Data Output
19	GND	Ground
20	GND	Ground
21	Rx2n	Receiver Inverted Data Output 3
22	Rx2p	Receiver Non-Inverted Data Output 3
23	GND	Ground
24	Rx4n	Receiver Inverted Data Output 3
25	Rx4p	Receiver Non-Inverted Data Output 3
26	GND	Ground
27	ModPrsL	Module Present
28	IntL	Interrupt
29	Vcc Tx	+3.3 V Power supply transmitter
30	Vcc 1	+3.3 V Power Supply
31	LPMODE	Low Power Mode
32	GND	Ground
33	Tx3p	Transmitter Non-Inverted Data Input
34	Tx3n	Transmitter Inverted Data Input
35	GND	Ground
36	Tx1p	Transmitter Non-Inverted Data Input
37	Tx1n	Transmitter Inverted Data Input

Figure 31: QSFP Connector Male and Female Views

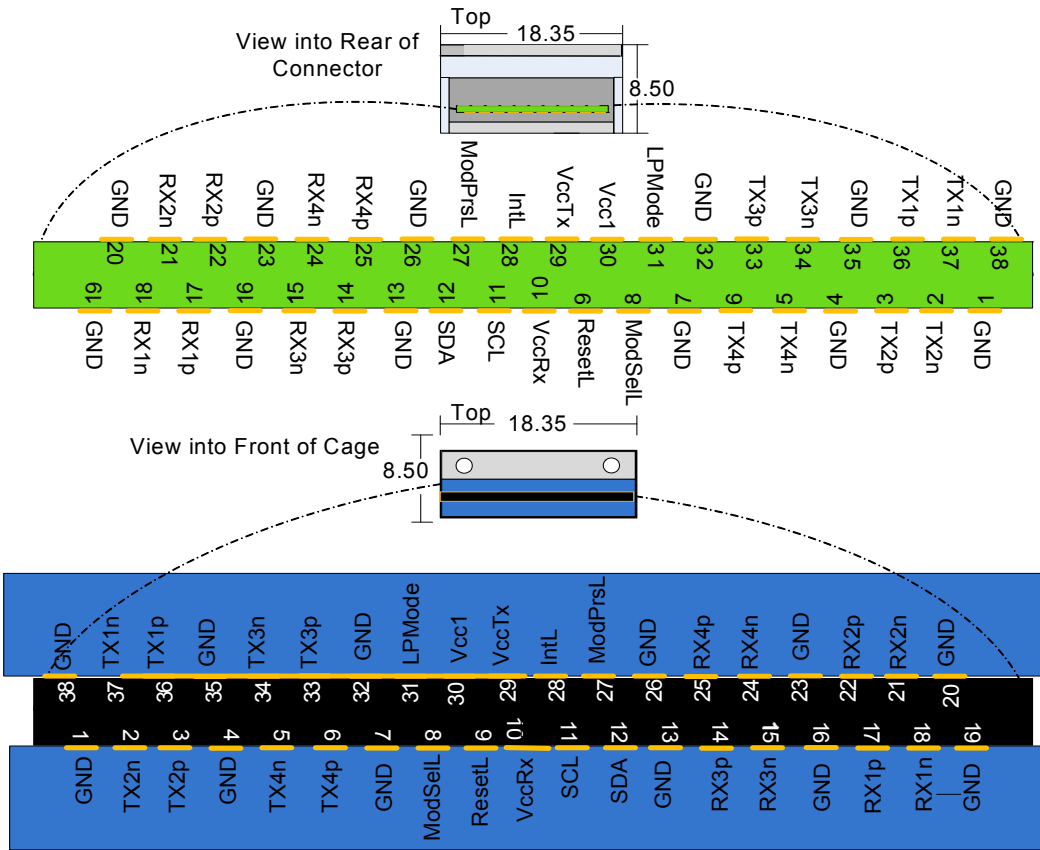

C.2 RJ-45 CONSOLE and I²C Interface

The RJ-45 CONSOLE and I²C interfaces are combined in the same connector. ...

Table 23 - RJ-45 CONSOLE and I²C Pinout

Signal	Pin#	Color
Not connected	1	G/W
I ² C_SCL	2	G
TXD	3	O/W
Not connected	4	Bl
GND	5	Bl/W
RXD	6	O
I ² C_SDA	7	Br/W
Not connected	8	Br

C.3 RJ45 to DB9 Harness Pinout

In order to connect a host PC to the Console RJ45 port of the system, a RS232 harness cable (DB9 to RJ45) is supplied.

Figure 32: RJ45 to DB9 Harness Pinout

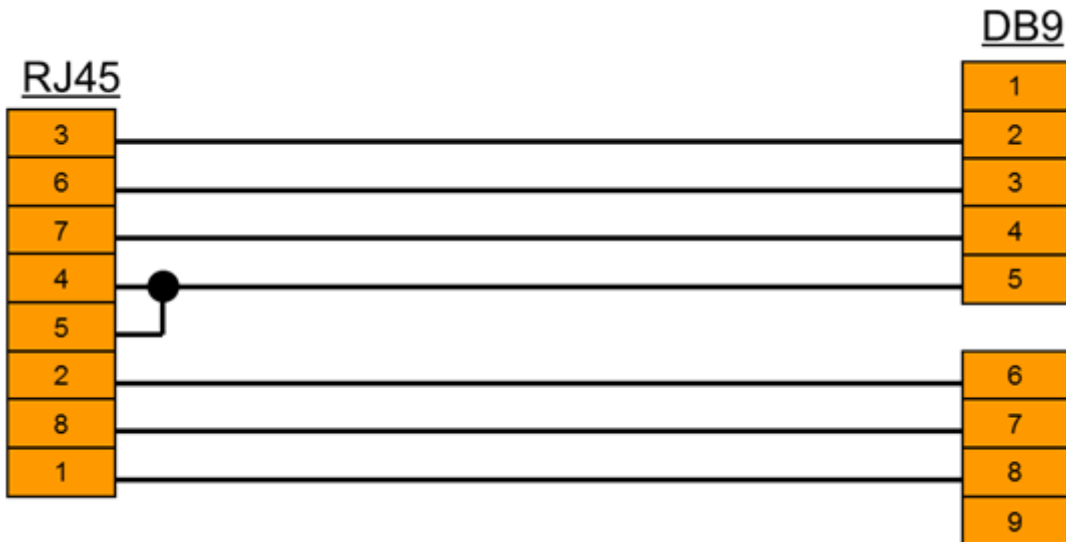

Appendix D: Disassembly and Disposal

D.1 Disassembly Procedure

➤ *To disassemble the system from the rack:*

1. Unplug and remove all connectors.
2. Unplug all power cords.
3. Remove the ground wire.
4. Unscrew the center bolts from the side of the system with the bracket.



Support the weight of the system when you remove the screws so that the system does not fall.

5. Slide the system from the rack.
6. Remove the rail slides from the rack.
7. Remove the caged nuts.

D.2 Disposal

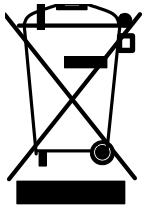

According to the WEEE Directive 2002/96/EC, all waste electrical and electronic equipment (EEE) should be collected separately and not disposed of with regular household waste.

Dispose of this product and all of its parts in a responsible and environmentally friendly way.

Follow the instructions found at http://www.mellanox.com/page/dismantling_procedures for proper disassembly and disposal of the switch, according to the WEEE directive.

Appendix E: Safety Warnings (Multiple Languages)

E.1 Nordic Countries Notices



In Finland: "Laite on liitettävä suojakoskettimilla varustettuun pistorasiaan"
 In Norway: "Apparatet må tilkoples jordet stikkontakt"
 In Sweden: "Apparaten skall anslutas till jordat uttag"

E.2 Installation Safety Warnings (English)

1. Installation Instructions



Read all installation instructions before connecting the equipment to the power source.

2. Bodily Injury Due to Weight



Use enough people to safely lift this product.

3. Heavy Equipment



This equipment is heavy and should be moved using a mechanical lift to avoid injuries.

4. Risk of Electric Shock!



Risk of Electric Shock!
 With the fan module removed power pins are accessible within the module cavity.
 DO NOT insert tools or body parts into the fan module cavity.

5. Over-temperature



This equipment should not be operated in an area with an ambient temperature exceeding the maximum recommended: 45°C (113°F). Moreover, to guarantee proper , allow at least 8cm (3 inches) of clearance around the ventilation openings.

6. Stacking the Chassis



The chassis should not be stacked on any other equipment. If the chassis falls, it can cause bodily injury and equipment damage.

7. Redundant Power Supply Connection - Electrical Hazard



This product includes a redundant power or a blank in its place. In case of a blank power supply, do not operate the product with the blank cover removed or not securely fastened.

8. Multiple Power Inlets



Risk of electric shock and energy hazard.
The PSUs are all independent.
Disconnect all power supplies to ensure a powered down state inside of the switch platform.

9. During Lightning - Electrical Hazard



During periods of lightning activity, do not work on the equipment or connect or disconnect cables.

10. Copper InfiniBand Cable Connecting/Disconnecting



Copper InfiniBand cables are heavy and not flexible, as such they should be carefully attached to or detached from the connectors. Refer to the cable manufacturer for special warnings/instructions.

11. Rack Mounting and Servicing



When this product is mounted or serviced in a rack, special precautions must be taken to ensure that the system remains stable. In general you should fill the rack with equipment starting from the bottom to the top.

12. Equipment Installation



This equipment should be installed, replaced, and/or serviced only by trained and qualified personnel.

13. Equipment Disposal



Disposal of this equipment should be in accordance to all national laws and regulations.

14. Local and National Electrical Codes



This equipment should be installed in compliance with local and national electrical codes.

15. UL Listed and CSA Certified Power Supply Cord



For North American power connection, select a power supply cord that is UL Listed and CSA Certified, 3 - conductor, [16 AWG], terminated with a molded plug rated at 125 V, [13 A], with a minimum length of 1.5m [six feet] but no longer than 4.5m. For European connection, select a power supply cord that is internationally harmonized and marked “<HAR>”, 3 - conductor, minimum 1.0 mm² wire, rated at 300 V, with a PVC insulated jacket. The cord must have a molded plug rated at 250 V, 10 A.

16. Installation codes



This device must be installed according to the latest version of the country national electrical codes. For North America, equipment must be installed in accordance to the applicable requirements in the US National Electrical Code and the Canadian Electrical Code.

17. Interconnection Of Units



Cables for connecting to the unit RS232 and Ethernet Interfaces must be UL certified type DP-1 or DP-2. (Note- when residing in non LPS circuit)

18. Overcurrent Protection



A readily accessible Listed branch circuit overcurrent protective device rated 20 A must be incorporated in the building wiring.

19. Do Not Use the Switch as a Shelf or Work Space

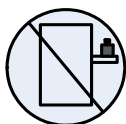

Caution: Slide/rail mounted equipment is not to be used as a shelf or a work space. The rails are not intended for sliding the unit away from the rack. It is for permanent installation at final resting place only, not used for service and maintenance

20. WEEE Directive

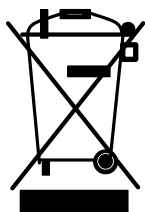

According to the WEEE Directive 2002/96/EC, all waste electrical and electronic equipment (EEE) should be collected separately and not disposed of with regular household waste.

Dispose of this product and all of its parts in a responsible and environmentally friendly way.

21. Country of Norway Power Restrictions



This unit is intended for connection to a TN power system and an IT power system of Norway only.

E.3 אזהרות בטיחות בהתקנה (עברית)

1. הוראות התקנה



קרא היטב את כל הוראות ההתקנה לפני חיבור המוצר לחשמל.

2. תקן ישראלי



יש להתקין את המוצר תוך הקפדה על תקנות החשמל הנהוגות בישראל, ולעשות שימוש ביחידת חלוקת כוח העומדת בתקן ישראלי (תי"י) 32.

3. חבלת גוף כתוצאה מנשיאת משקל יתר



נדרשת נוכחותם של מספר מתקינים כדי להרים את המוצר בבטחה.

4. ציוד כבד



המוצר כבד ויש לשנעו באמצעות מעלית מכאנית כדי למנוע חבלה.

5. סכנת התחשמלות!



סכנת התחשמלות:

בעת שיחידת המאוורר מפורקת, רכיבי חשמל נחשפים בחלל הריק. אין להחדיר כלים או איברי גוף לחלל המיועד להרכבת היחידה.

6. התחממות יתר



אין להפעיל את המוצר באיזור שבו טמפרטורת החדר עולה על הטמפרטורה המקסימלית המומלצת: 45°C (113°F).

בנוסף, כדי להבטיח כניסת אוויר תקינה, יש לוודא כי קיים שטח פנוי של 8 ס"מ (3 אינץ') לפחות סביב פתחי האוורור.

7. ערימת המערכת



אין לערום את המערכת על גבי ציוד אחר. במקרה של נפילה, עשויים להגרם נזקי גוף ורכוש.

8. חיבור ספק כוח נוסף - סכנת חשמל



המערכת מכילה ספק כוח נוסף לגיבוי או, בחלק מהמקרים, חלל ריק המאפשר הרכבת ספק כזה. אין לעשות שימוש במערכת כשהמכסה החוסם את החלל הריק אינו סגור כהלכה.

9. מספר שקעים חשמליים



סכנת התחשמלות ואזהרת אנרגיה.

כל אחד מספקי הכוח פועל באופן עצמאי. יש לנתק את כל ספקי הכוח כדי להבטיח ניתוק מוחלט של המערכת מזרם חשמלי.

10. בעת סופות ברקים - סכנת חשמל



בעת סופות ברקים, אין להפעיל את המערכת או לחבר/לנתק כבלים.

11. חיבור או ניתוק של כבלי אינפיניבאנד מנחושת



כבלי InfiniBand מנחושת הם כבדים וקשיחים. לפיכך, יש לחברם ולנתקם מהמחברים בזהירות רבה. לאזהרות נוספות, יש לעיין בעלון לצרכן מטעם יצרן הכבלים.

12. הרכבה על גבי מדף בארון



כאשר מרכיבים מוצר זה על גבי מדף בארון, יש לנקוט באמצעי זהירות מיוחדים בכדי להבטיח שיוותר יציב. ככלל, יש למלא את מדפי הארון החל מהתחתון ועד לעליון.

13. התקנת המוצר



כל התקנה, החלפה או טיפול במוצר זה חייבת להתבצע על ידי איש צוות מיומן ומוסמך בלבד.

14. השלכת פסולת



השלכת המוצר בתום השימוש חייבת להיעשות בהתאם לכל התקנות והחוקים הלאומיים.

15. תקנות חשמל מקומיות ולאומיות



יש להתקין מערכת זו בהתאם לתקנות החשמל המקומיות והלאומיות.

16. כבל אספקת חשמל



על מנת לחבר את המוצר לחשמל בצפון אמריקה, יש לבחור כבל חשמלי מאושר UL ובעל הסמכת CSA, 3 - מוליך, [AWG 16], שבקצהו תקע מובנה 125V 13A, אורכו המינימלי 1.5 מטר (6 אינץ') ואורכו המקסימלי 4.5 מטר.

לחיבור אירופאי, בחר כבל חשמלי בעל התאמה בינלאומית וסימון "<HAR>", 3 - מוליך, גידים פנימיים באורך מינימלי של 1.0 מילימטר², 300 V, עם עטיפת PVC מבודדת. על הכבל לכלול תקע מובנה 10A, V 250.

17. תקנות התקנה



יש להתקין מערכת זו על פי הגרסה האחרונה של תקנות החשמל הלאומיות הנהוגות במדינה. עבור צפון אמריקה, יש להתקין את המערכת בהתאם לתקנות החשמל הלאומיות המיושמות בארה"ב ובקנדה.

18. חיבור בין מערכות



על כבלים לחיבור היחידה לממשקי RS232 ו-Ethernet להיות בעלי הסמכת UL מסוג DP-1 או DP-2 (כאשר הם מצויים במעגל חשמלי שאינו מקור כוח מוגבל).

19. הגנה מפני מתח גבוה



יש להקפיד על המצאותם בבניין ועל זמינותם של אמצעים להגנה מפני מתח גבוה בתקן 20A.

20. אין להשתמש במערכת כמדף או שטח עבודה



זהירות: אין להשתמש בציוד כמדף או שטח עבודה. המסילות לא נועדו לשליפת המערכת מהארון, אלא להתקנה במיקומו הקבוע והסופי של הארון.

21. תקנת WEEE

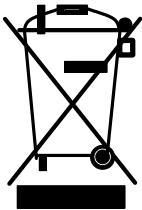

על פי תקנת WEEE 2002/96/EC, יש להשליך את כל פסולת הציוד החשמלי והאלקטרוני בנפרד מפסולת ביתית רגילה.

בתום השימוש, השלך לאשפה את המוצר הזה ואת כל חלקיו באופן אחראי וידידותי לסביבה.

22. מגבלות חשמליות בנורבגיה



יחידה זו מיועדת לחיבור למערכת אספקת חשמל מסוג TN וקמערכת אספקת חשמל מסוג IT, בנורבגיה בלבד.

E.4 安裝安全性警告 (Chinese)

1. 安裝指示



本設備附有備援電源供應器或在適當位置配有空白蓋板。

2. 因重量導致的人身受傷



為了安全起見，請安排足夠的人員以合力抬起本產品。

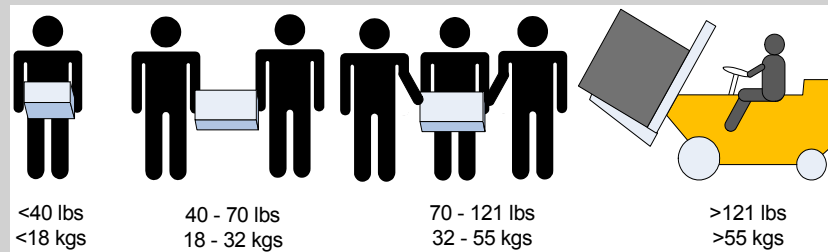

3. 重設備



本設備極重，應使用機械式起重機來搬移，以避免人員受傷。

4. 有觸電的危險



有觸電的危險！
拆除風扇模組後，即可接觸到模組空腔內的電源針腳。
請勿將工具或機身零件插入到風扇模組空腔內。

5. 溫度過高



本設備不應在超過所建議的最高環境溫度的區域中運作：45°C (113°F)。此外，為了保證氣流的流通正常，請在通風口旁保留至少 8 公分 (3 英吋) 的間距。

6. 堆疊機箱



機箱不應堆疊在任何其他設備上。如果機箱掉落，可能造成人員受傷與設備損壞。

7. 複式電源連接時的電擊危險



本設備附有備援電源供應器或在適當位置配有空白蓋板。如果是電源供應器空白蓋板，在空白蓋板已取下或未牢牢固訂的情況下，請勿操作本產品。

8. 多電源輸入座



電擊與能源危害的危險。
所有 PSU 均各自獨立。
將所有電源供應器斷電，確保交換器平台內部在電源關閉狀態。

9. 閃電時的電擊危險



在閃電期間，不要使用本設備或連接或拔下纜線。

10. InfiniBand 銅纜連接 / 拔下



InfiniBand 銅纜很重且沒有彈性，因此必須小心裝在連接器上或自連接器上拔下。如需相關的特殊警告 / 指示，請洽詢纜線製造商。

11. 機架安裝與維修



此產品已安裝在機架中或在機架中維修時，必須採取特定預防措施以確保系統維持穩定。一般您應該將設備從底部到頂端放滿機架。

12. 設備安裝



本設備僅限由經過訓練與 / 或合格的人員安裝、更換或維修。

13. 設備棄置



棄置本設備應遵照所有國內法規。

14. 當地與國家電氣法規



請遵照當地與國家電氣法規安裝本設備。

15. UL 列名和 CSA 認證電源線



北美地區在接上電源時，請選用獲得 UL 列名和 CSA 認證、三個導體、[16 AWG] 附成型插頭，額定值為 125 V、[13 A]，長度至少 1.5 公尺 [六英尺]，但不超過 4.5 公尺的電源線。

歐洲地區在接上電源時，請選用國際協調式且標示有 <HAR> 字樣、三個導體、標稱截面至少 1.0 平方公厘，額定值為 300 V，採用 PVC 絕緣的電源線。電源線需有成型插頭，額定值為 250 V, 10 A。

16. 高漏電流



警告：高漏電流；必須執行地線連接，然後再連接電源供應器。

17. 安裝法規



請務必遵循最新版的國家電氣法規，安裝本設備。在北美地區，請務必遵循美國國家電工法規和加拿大電工法規中的適用規定，安裝本設備。

18. 互連設備



連接至 RS232 設備和乙太網路介面的纜線必須是 UL 認證類型 DP-1 或 DP-2。
(請注意位於非 LPS 電路時)

過電流保護：準備好使用的列名分支電路過電流保護裝置最大額定值 20 A 必須整合在配線中。

19. 切換開關不可用作機架或工作空間

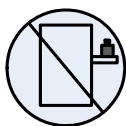

小心：滑軌 / 導軌安裝設備不可用作機架或工作空間。導軌不適用於將設備滑出機架使用。僅限永久安裝在最後安置區域時使用，不可用於維修和保養。

20. WEEE 指令

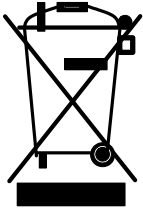

根據 WEEE 指令 2002/96/EC，所有廢棄的電氣與電子設備 (EEE)，應分開集中，而且不應與一般家庭廢棄物一起棄置。
請以負責和環保的方式棄置本產品及其所有零件。

21. 挪威國家電源限制



本設備僅限連接至挪威的 TN 電源系統和 IT 電源系統。

E.5 Avertissements de sécurité pour l'installation (French)

1. Instructions d'installation



Veuillez lire la totalité des instructions d'installation avant de relier l'équipement au secteur.

2. Blessures à cause du poids



Prévoyez assez de personnel pour soulever ce produit en toute sécurité.

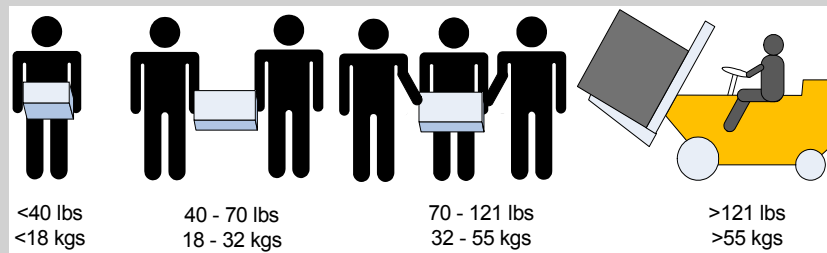

3. Équipement lourd



Cet équipement est lourd et doit être déplacé avec un système de levage mécanique pour éviter les blessures.

4. Danger d'électrocution



Danger d'électrocution !

Lorsque le module de ventilation est retiré, les broches d'alimentation sont exposées dans l'emplacement du module.

NE PAS insérer d'outils ou la main dans l'emplacement du module.

5. Surchauffe



Cet équipement ne doit pas être en service dans un local dont la température dépasse le maximum recommandé de 45°C (113°F). En outre et pour garantir une circulation d'air correcte, laisser un espace d'au moins 8 cm (3") autour des orifices de ventilation.

6. Châssis empilé sur d'autres équipements



Le châssis ne doit pas être empilé sur d'autres équipements. S'il tombe, il peut endommager l'équipement ou entraîner des blessures.

7. Connexion de l'alimentation redondante : danger d'électrocution



Ce produit est équipé d'une alimentation redondante ou d'un cache si elle est absente. Dans ce dernier cas, ne pas faire fonctionner le produit si le cache est retiré ou mal fixé.

8. Plusieurs prises d'alimentation



Risque et danger d'électrocution.

Les alimentations sont toutes indépendantes.

Pour s'assurer que le commutateur est bien hors tension, débranchez toutes les alimentations.

9. En cas d'orage, danger d'électrocution



Pendant un orage, ne pas travailler sur l'équipement ni brancher ou débrancher des câbles.

10. Connexion et déconnexion du câble InfiniBand en cuivre



Les câbles InfiniBand en cuivre sont lourds et peu flexibles. Par conséquent, il faut procéder avec soin pour les brancher ou les débrancher des connecteurs. Consulter le fabricant du câble pour obtenir des instructions ou des avertissements spécifiques.

11. Montage en rack et maintenance



Lors du montage ou de la maintenance de ce produit dans un rack, il faut faire spécialement attention pour s'assurer que l'ensemble reste stable. En règle générale, le rack doit être rempli en commençant par le bas.

12. Installation de l'équipement



Cet équipement ne doit être installé, remplacé et maintenu que par un personnel formé et qualifié.

13. Mise au rebut de l'équipement



La mise au rebut de cet équipement doit se faire conformément à toutes les lois et réglementations nationales.

14. Codes électriques locaux et nationaux



Cet équipement doit être installé conformément aux codes électriques locaux et nationaux.

15. Codes d'installation



Cet appareil doit être installé conformément à la version la plus récente des codes électrique nationaux. En Amérique du Nord, l'équipement doit être installé en respectant les exigences de l'US National Electrical Code et du Code canadien de l'électricité.

16. Cordon d'alimentation UL Listed et certifié CSA



Pour le branchement électrique en Amérique du Nord, utiliser un cordon d'alimentation UL Listed et CSA Certified, à 3 conducteurs [calibre 16 AWG], avec une prise moulée 125 V [13 A], faisant au moins 1,5 m de long [six pieds] et au plus 4,5 m. Pour le branchement électrique en Europe, utiliser un cordon d'alimentation au format international harmonisé (marqué <HAR>), à 3 conducteurs d'au moins 1 mm² de section, 300 V, avec une gaine isolante en PVC. Le cordon doit avoir une prise moulée 250 V 10 A.

17. Courant de fuite élevé



Avertissement : courant de fuite élevé, une connexion à la terre est indispensable avant de brancher l'alimentation.

18. Interconnexion des unités



Les câbles de connexion aux interfaces RS232 et Ethernet de l'appareil doivent être certifié UL de type DP-1 ou DP-2. (Note : en cas d'installation sur un circuit dont la puissance n'est pas limitée)

Protection contre les surintensités : le câblage de l'immeuble doit intégrer un dispositif certifié de protection contre les surintensités, calibré à 20 A et aisément accessible.

19. Ne pas utiliser comme étagère ou plan de travail

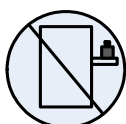

Attention : un équipement coulissant ou monté sur rail ne doit pas servir d'étagère ni de plan de travail. Les rails ne sont pas destinés à faire coulisser l'unité hors du rack. Ils sont destinés à une installation permanente à l'emplacement final, pas pour l'entretien ni la maintenance.

20. Directive DEEE

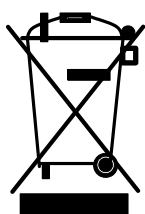

Selon la Directive 2002/96/CE (DEEE), tous les déchets d'équipements électriques et électroniques (EEE) doivent être collectés séparément et ne pas être mis au rebut avec les déchets ménagers habituels.

Ce produit et toutes ses pièces doivent être mis au rebut d'une manière responsable, respectant l'environnement.

21. Restrictions concernant l'alimentation pour la Norvège



Cet appareil est prévu pour être relié à un système d'alimentation TN et un système d'alimentation informatique de Norvège uniquement.

E.6 Installation Sicherheitshinweise(German)

1. Installationsanleitungen



Lesen Sie alle Installationsanleitungen, bevor Sie das Gerät an die Stromversorgung anschließen.

2. Verletzungsgefahr wegen des Gewichts



Um das Produkt sicher anzuheben, genügend Personen einsetzen.

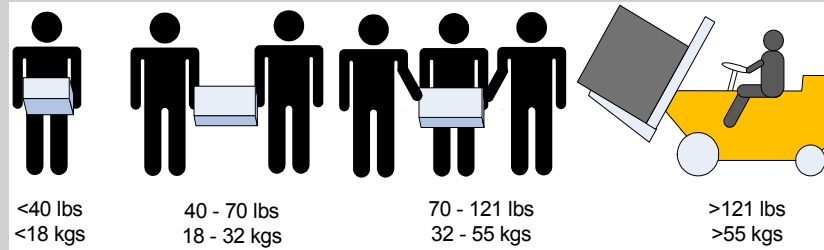

3. Schweres Gerät



Dieses Gerät ist schwer und muss mit einem mechanischen Hebegerät verschoben werden, um Verletzungen zu vermeiden.

4. Stromschlagrisiko



Stromschlagrisiko!

Bei abgenommenem Ventilatormodul sind die Stromkontakte in der Modulvertiefung zugänglich.

Es dürfen KEINE Werkzeuge oder Körperteile in die Vertiefung des Ventilatormoduls gelangen.

5. Übertemperatur



Dieses Gerät sollte nicht in einem Bereich mit einer Umgebungstemperatur über der maximal empfohlenen Temperatur von 45°C (113°F) betrieben werden. Es ist ein Luftstrom von 200 LFM bei maximaler Umgebungstemperatur erforderlich. Außerdem sollten mindestens 8 cm (3 in.) Freiraum um die Belüftungsöffnungen sein, um einen einwandfreien Luftstrom zu gewährleisten.

6. Stapeln des Chassis



Das Chassis sollte nicht auf andere Geräte gestapelt werden. Wenn das Chassis heruntermfällt, kann es zu Verletzungen und Beschädigungen an Geräten führen.

7. Mehrere Stromeingänge



Risiko eines Stromschlags und Stomgefahr.

Alle Stromversorgungseinheiten sind unabhängig.

Trennen Sie alle Stromversorgungen, um einen abgeschalteten Zustand im Inneren der Switch-Plattform sicherzustellen.

8. Bei Gewitter - Elektrische Gefahr



Arbeiten Sie während eines Gewitters und Blitzschlag nicht am Gerät, schließen Sie keine Kabel an oder ab.

9. Anschließen/Trennen von InfiniBand-Kupferkabel



InfiniBand-Kupferkabel sind schwer und nicht flexible. Deshalb müssen sie vorsichtig an die Anschlüsse angebracht bzw. davon getrennt werden. Lesen Sie die speziellen Warnungen und Anleitungen des Kabelherstellers.

10. Rack-Montage und Wartung



Wenn dieses Produkt in einem Rack montiert oder gewartet wird, sind besondere Vorsichtsmaßnahmen zu ergreifen, um die Stabilität des Systems zu gewährleisten. Im Allgemeinen sollten Sie das Gestell von unten nach oben mit Geräten füllen.

11. Geräteinstallation



Diese Gerät sollte nur von geschultem und qualifiziertem Personal installiert, ausgetauscht oder gewartet werden.

12. Geräteentsorgung



Die Entsorgung dieses Geräts sollte unter Beachtung aller nationalen Gesetze Bestimmungen erfolgen.

13. Regionale und nationale elektrische Bestimmungen



Dieses Gerät sollte unter Beachtung der regionalen und nationalen elektrischen Bestimmungen installiert werden.

14. Installationscodes



Dieses Gerät muss entsprechend der aktuellsten Version des National Electrical Code installiert werden. In Nordamerika muss das Gerät gemäß den geltenden Anforderungen des US National Electrical Code und des Canadian Electrical Code installiert werden.

15. UL- und CSA-zertifiziertes Netzkabel



Für Nordamerika Stromanschluss, wählen Sie ein Netzkabel, das UL-und CSA Certified

3 - Leiter, [18 AWG], mit einem angespritztem Stecker bewertet bei 125 V, [15], mit einer Mindestlänge von 1,5 m [Six Feet] aber nicht mehr als 4,5 m.

Für die europäischen Zusammenhang, wählen Sie ein Netzkabel, das international harmonisiert und der Aufschrift "<HAR>",

3 - Leiter, mindestens 0,75 mm² Draht, bewertet mit 300 V, mit einem PVC-Mantel isoliert. Das Kabel muss eine angespritztem Stecker bewertet bei 250 V, 10 A. "

16. Hoher Ableitstrom



WARNUNG: Hohe Ableitstrom; Earth Verbindung, bevor Sie die Verbindung von wesentlicher Bedeutung werden.

17. Installationscodes



Dieses Gerät muss installiert sein, entsprechend auf die neueste Version des Landes National Electrical Code. Für Nordamerika, müssen in Übereinstimmung mit den geltenden Vorschriften in der US-amerikanischen National Electrical Code und dem Canadian Electrical Code.

18. Verbindung der Geräte untereinander



Kabel für den Anschluss an das Gerät RS232-und Ethernet-Schnittstellen müssen UL zertifiziert Typ DP-1 oder DP-2. (Hinweis-, wenn nicht mit Wohnsitz in LPS-Schaltung)

Überstromschutz: Eine leicht zugängliche Auflistung Abzweigung Überstrom-Schutzeinrichtung 20 A bewertet werden müssen in dem Gebäude Verkabelung.

19. Switch nicht als Regal oder Arbeitsplatz nutzen

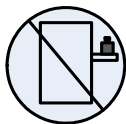

Achtung: Auf Schieber/Schienen montiertes Gerät ist nicht als Regal oder Arbeitsbereich zu nutzen. Die Schienen sind nicht dafür bestimmt, die Einheit aus dem Gestell weg zu ziehen. Sie sind nur für die permanente Installation an einem endgültigen Standort gedacht, nicht für Instandhaltung und Wartung.

20. WEEE-Direktive

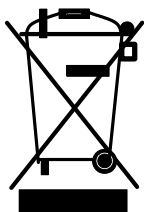

Gemäß WEEE Directive 2002/96/EC müssen alle elektrischen und elektronischen Abfallgeräte (EEE) separat gesammelt und nicht mit normalem Haushaltsmüll entsorgt werden.

Dieses Produkt und alle seine Teile in verantwortungsvoller und umweltfreundlicher Art und Weise entsorgen.

E.7 Advertencias de seguridad de instalación (Spanish)

1. Instrucciones de instalación



Antes de conectar el equipo a la fuente de alimentación, leer todas las instrucciones de instalación.

2. Lesión corporal a causa de peso



Recurra a suficientes personas para levantar este producto sin

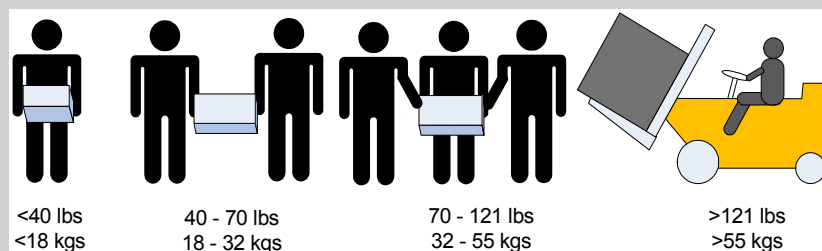

3. Equipos pesados



Dado que el equipo es pesado, se debe mover únicamente mediante un elevador mecánico, para evitar lesiones.

4. Riesgo de descarga eléctrica



¡Riesgo de descarga eléctrica!

Con el módulo del ventilador quitado, se obtiene acceso a las clavijas de alimentación desde dentro de la cavidad del módulo.

NO introducir herramientas ni partes del cuerpo en la cavidad del módulo del ventilador.

5. Sobretemperatura



No se debe utilizar el equipo en un área con una temperatura ambiente superior a la máxima recomendada: 45°C. Además, para garantizar una circulación de aire adecuada, se debe dejar como mínimo un espacio de 8 cm (3 pulgadas) alrededor de las aberturas de ventilación.

6. Apilamiento del chasis



Los chasis no se deben apilar sobre otros equipos. La caída del chasis podría causar lesiones corporales, así como daños al equipo.

7. Conexión redundante de fuente de alimentación: peligro de descarga



Este producto incluye una fuente de alimentación redundante o, en su lugar, una vacía. Si se dispone de una fuente de alimentación vacía, no utilizar el producto si su tapa está quitada o no está bien cerrada.

8. Tomas de alimentación múltiples



Riesgo de descarga eléctrica y peligro de corriente.
Todas las fuentes de alimentación son independientes.
Desconecte todas las fuentes de alimentación, para asegurar que no haya corriente alguna dentro de la plataforma de conmutación.

9. Al haber rayos: peligro de descarga



No utilizar el equipo ni conectar o desconectar cables durante períodos de actividad de rayos.

10. Cable de conexión y desconexión InfiniBand de cobre



Dado que los cables de cobre InfiniBand son pesados y no son flexibles, su conexión a los conectores y su desconexión se deben efectuar con mucho cuidado. Para ver advertencias o instrucciones especiales, consultar al fabricante del cable.

11. Montaje y mantenimiento del bastidor



Al instalar o realizar el mantenimiento de este aparato en un bastidor, es preciso adoptar precauciones especiales para garantizar que el sistema se mantenga estable. En general, en un bastidor, los equipos se deben instalar comenzando desde abajo hacia arriba.

12. Instalación del equipo



La instalación, el reemplazo y el mantenimiento de este equipo estarán a cargo únicamente de personal capacitado y competente.

13. Eliminación del equipo



La eliminación definitiva de este equipo se debe efectuar conforme a todas las leyes y reglamentaciones nacionales.

14. Códigos eléctricos locales y nacionales



Este equipo se debe instalar conforme a los códigos eléctricos locales y nacionales.

15. Códigos de instalación



Este dispositivo se debe instalar conforme a la versión más reciente de los códigos eléctricos nacionales del país en cuestión. En América del Norte, el equipo se debe instalar de acuerdo con las disposiciones vigentes del Código Eléctrico Nacional de los EE.UU. y del Código Eléctrico de Canadá.

16. Cable de alimentación homologado por UL y con certificación CSA



En conexiones de América del Norte, seleccionar un cable de alimentación homologado por UL y con certificación CSA de tres conductores, [16 AWG], terminado en un enchufe moldeado con capuchón de 125 voltios nominal, [13 A], con una longitud mínima de 1,5 metros, pero no más de 4,5 metros.

En conexiones europeas, seleccionar un cable de alimentación armonizado internacionalmente y marcado "<HAR>", de tres conductores, hilo de 1,0 mm² como mínimo, 300 voltios nominal, con cobertura protectora aislante de PVC. El cable debe tener un enchufe moldeado con capuchón de 250 voltios nominal, 10 A.

17. Alta corriente de fuga



ADVERTENCIA: Alta corriente de fuga. Es esencial efectuar la conexión a tierra antes de conectar la alimentación.

18. Códigos de instalación



Este dispositivo se debe instalar conforme a la versión más reciente de los códigos eléctricos nacionales del país en cuestión. En América del Norte, el equipo se debe instalar de acuerdo con las disposiciones vigentes del Código Eléctrico Nacional de los EE.UU. y del Código Eléctrico de Canadá.

19. Interconexión de unidades



Los cables para la conexión con las interfaces RS232 y Ethernet de la unidad deben estar homologados por UL tipo DP-1 o DP-2. (Nota: cuando residen en circuito no de tipo LPS)

Protección contra sobrecargas: Al cableado del edificio se debe incorporar un dispositivo de protección contra sobrecargas de circuito derivado, de fácil acceso, con una corriente nominal de 20 A.

20. No utilizar el conmutador como estante ni como espacio de trabajo

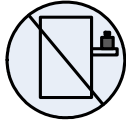

Cuidado: Equipos montados en deslizadores o rieles no se deben utilizar como estantes ni como espacio de trabajo. La finalidad de los rieles no es deslizar la unidad hacia afuera del bastidor. Sirven solo para la instalación permanente en el lugar de destino final, no para fines de servicio o mantenimiento

21. Directiva WEEE

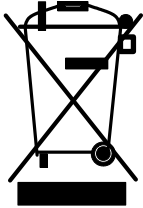

Conforme a la Directiva 2002/96/CE sobre RAEE, todos los residuos de equipos eléctricos y electrónicos (EEE) se deben recolectar por separado y no se deben eliminar junto con residuos domésticos.

Al deshacerse de este producto y de todas sus partes, hágalo de una manera responsable y respetuosa con el medio ambiente.

E.8 Предупреждения по технике безопасности при установке (Russian)

1. Инструкция по установке



Перед подключением оборудования к источнику питания следует ознакомиться с инструкцией по установке.

2. Травмы при переносе тяжелых предметов



Для поднятия этого изделия следует задействовать достаточное количество людей.

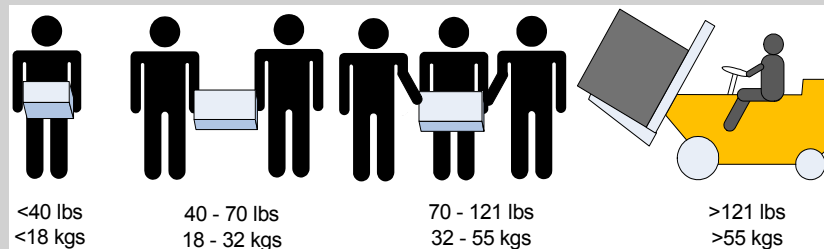

3. Тяжелое оборудование



Это тяжелое оборудование, поэтому его следует перемещать с помощью механического подъемника во избежание травм.

4. Опасность поражения электрическим током



Опасность поражения электрическим током!

Когда снят вентиляторный модуль, существует возможность повреждения контактов питания в его углублении.

НЕ вставлять инструменты или части тела в углубление вентиляторного модуля.

5. Перегрев



Не эксплуатировать это оборудование в помещении с температурой окружающей среды, превышающей максимально рекомендуемое значение: 45 °C (113 °F).

Более того, для надлежащей вентиляции следует обеспечить зазор вокруг вентиляционных отверстий не менее 8 см (3 дюйма).

6. Установка шасси поверх другого оборудования



Не устанавливать шасси поверх другого оборудования. Падение шасси может привести к травмам и повреждению оборудования.

7. Опасность поражения электрическим током резервного источника питания



В этом изделии установлен резервный источник питания или модуль-заглушка. Если установлен модуль-заглушка, не эксплуатировать изделие со снятой или ненадежно закрепленной крышкой модуля-заглушки.

8. Несколько источников питания



Опасность поражения электрическим током и опасные энергетические воздействия.

Блоки питания независимы друг от друга.

Чтобы обесточить все компоненты внутри платформы коммутации, следует отсоединить все блоки питания.

9. Опасность поражения электрическим током во время грозы



Во время грозы запрещается использовать оборудование и подключать или отключать кабели.

10. Подсоединение и отсоединение медных кабелей InfiniBand



Медные кабели InfiniBand тяжелые и негибкие, поэтому следует осторожно их подсоединять и отсоединять. За особыми предупреждениями и указаниями следует обратиться к производителю кабеля.

11. Установка или обслуживание в стойке



При установке или обслуживании этого изделия в стойке следует обеспечить устойчивость системы. Как правило, стойка заполняется оборудованием снизу вверх.

12. Установка оборудования



Устанавливать, заменять и/или обслуживать это оборудование должен только подготовленный и квалифицированный персонал.

13. Утилизация оборудования



Это оборудование утилизируется в соответствии с национальными законами и постановлениями.

14. Местные и национальные правила установки электрооборудования



Это оборудование устанавливается в соответствии с местными и национальными правилами установки электрооборудования.

15. Правила установки электрооборудования



Это устройство устанавливается в соответствии с последним изданием национальных правил установки электрооборудования. В Северной Америке оборудование устанавливается в соответствии с действующими требованиями Национальных правил эксплуатации и обслуживания электрических установок США и Канады.

16. Шнур питания, включенный в номенклатуру UL и сертифицированный Канадской ассоциацией стандартизации (CSA)



Подключение к электропитанию в Северной Америке выполняется с помощью шнура питания, включенного в номенклатуру UL и сертифицированного Канадской ассоциацией стандартизации (CSA), 3-жильного, [16 AWG], длиной от 1,5 м [6 футов] до 4,5 м, с литой вилкой, рассчитанной на 125 В [13 А].
Подключение к электропитанию в Европе выполняется с помощью гармонизированного шнура питания с маркировкой <HAR>, 3-жильного, с сечением жилы не менее 1,0 мм², рассчитанного на номинальное напряжение 300 В, с ПВХ оболочкой. Шнур должен иметь литую вилку, рассчитанную на 250 В, 10 А.

17. Высокий ток утечки



Осторожно! Высокий ток утечки. Заземлить перед подключением к электропитанию.

18. Подсоединение устройств



Для подключения к разъемам RS232 и Ethernet используются кабели типа DP-1 или DP-2, сертифицированные организацией UL. (Примечание. При подключении к сети без ограниченного источника электропитания) Максимальная токовая защита. В проводку здания в легкодоступном месте следует включить устройство защиты от перегрузки по току номиналом 20 А.

19. Не использовать коммутатор как полку или рабочую

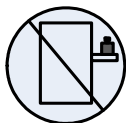

Внимание! Оборудование, установленное на направляющих, не должно использоваться как полка или рабочая поверхность. Направляющие не предназначены для удерживания устройства, выдвинутого из стойки. Они предназначены для стационарной установки только в конечном положении и не используются для обслуживания устройства.

20. Директива WEEE

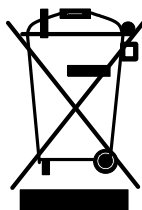

В соответствии с Директивой 2002/96/EC (WEEE) отходы электрического и электронного оборудования должны собираться и утилизироваться отдельно от обычных бытовых отходов.

Следует утилизировать это изделие и все его части ответственным и экологически безопасным способом.

E.9 Avertismente privind siguranța la instalare (Romanian)

1. Instrucțiuni de instalare



Citiți toate instrucțiunile de instalare înainte de a conecta

2. Accidentare cauzată de greutate



Apelați la un număr suficient de persoane pentru a ridica în siguranță acest produs.

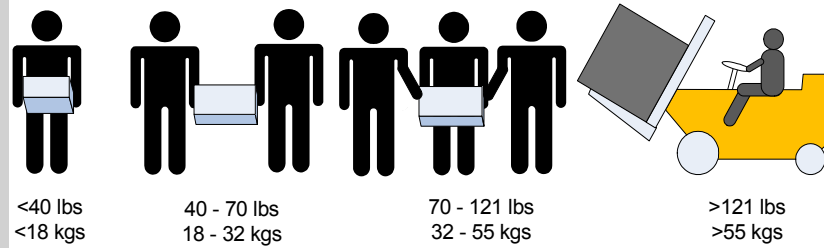

3. Echipament greu



Acest echipament este greu și trebuie să fie mutat folosind un dispozitiv mecanic de ridicare pentru a evita producerea de leziuni.

4. Risc de șoc electric



Risc de șoc electric!

Odată ce modulul ventilator este îndepărtat, pinii electrici sunt accesibili în cavitatea modulului.

NU introduceți instrumente sau părți din corp în cavitatea modulului ventilator.

5. Temperatură în exces



Acest echipament nu trebuie să fie acționat într-o zonă unde temperatura ambiantă depășește valoarea maximă recomandată: 45°C (113°F). În plus, pentru a asigura un flux de aer adecvat, lăsați un spațiu liber de cel puțin 8 cm (3 inchi) în jurul fanțelor de ventilare.

6. Suprapunerea cadrului



Cadrul nu trebuie să fie suprapus peste niciun alt echipament. În cazul în care cadrul cade, poate cauza leziuni corporale și deteriorări ale echipamentului.

7. Conexiunea la o sursă de alimentare electrică suplimentară - pericol electric



Acest produs include o sursă de alimentare suplimentară sau un spațiu gol în locul acesteia. În cazul în care spațiul pentru sursa de alimentare este gol, nu operați produsul când capacul orb este îndepărtat sau nu este fixat în mod sigur.

8. Multiple mufe electrice



Risc de șoc electric și pericol electric.
Toate aparatele cu alimentare de la rețea sunt independente.
Deconectați toate sursele de alimentare cu energie pentru a asigura decuplarea în interiorul platformei de comutare.

9. În timpul descărcărilor electrice - pericol electric



În timpul perioadelor cu descărcări electrice luminoase, nu lucrați cu echipamentul sau nu conectați sau deconectați cablurile.

10. Conectarea/deconectarea cablului din cupru InfiniBand



Cablurile InfiniBand din cupru sunt grele și inflexibile, de aceea trebuie să fie atașate sau detașate de conectori cu grijă. Consultați producătorul de cabluri pentru avertismente/instrucțiuni speciale.

11. Montarea sau depanarea într-un rack



Când acest produs este montat sau depanat într-un rack, trebuie să fie luate măsuri de precauție speciale pentru a se asigura că sistemul rămâne stabil. În general, trebuie să umpleți rack-ul cu echipamente începând de jos în sus.

12. Instalarea echipamentului



Acest echipament trebuie să fie instalat, înlocuit și/sau depanat numai de către personal instruit și calificat.

13. Eliminarea echipamentului



Eliminarea acestui echipament trebuie să se realizeze în conformitate cu toate legile și regulamentele naționale.

14. Codurile electrice locale și naționale



Acest echipament trebuie să fie instalat conform codurilor electrice locale și naționale.

15. Codurile ed instalare



Acest dispozitiv trebuie să fie instalat în conformitate cu ultima versiune a codurilor electrice naționale ale țării în cauză. Pentru America de Nord, echipamentul trebuie să fie instalat conform cerințelor aplicabile din Codul electric național al SUA și Codul electric canadian.

16. Cordon de alimentare electrică înregistrat UL și certificat CSA



Pentru conectarea la o sursă de alimentare pentru America de Nord, selectați un cordon de alimentare care este înregistrat UL și certificat CSA, cu 3 conductoare, [16 AWG], terminat cu o fișă turnată, cu putere nominală egală cu 125 V, [13 A], cu o lungime de minimum 1,5 m [șase picioare], dar nu mai lung de 4,5 m.

Pentru conectarea la o sursă de alimentare în Europa, selectați un cordon de alimentare care este armonizat la nivel internațional și marcat „<HAR>”, cu 3 conductoare, cu minimum 2 fire de 1,0 mm, cu putere nominală egală cu 300 V și cu o manta izolantă din PVC. Cordonul de alimentare trebuie să fie prevăzut cu o fișă turnată cu putere nominală egală cu 250 V, 10 A.

17. Curent de scurgere de înaltă frecvență



Avertisment: Curent de scurgere de înaltă frecvență; Împământarea este esențială înainte de a conecta sursa de alimentare.

18. Interconectarea unităților



Cablurile pentru conectarea la unitatea RS232 și la interfețele Ethernet trebuie să fie de tipul DP-1 sau DP-2 certificate UL. (Notă- când se regăsesc într-un circuit non-LPS)

Protecție la supracurent: Un dispozitiv de protecție la supracurent, înregistrat în circuitul de ramificare, ușor accesibil și cu o putere nominală egală cu 20 A trebuie să fie integrat în cablajul clădirii.

19. Nu utilizați comutatorul ca raft sau spațiu de lucru

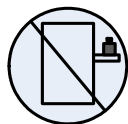

Atenție: Echipamentul montat pe o linie de alunecare/șină nu va fi utilizat ca raft sau spațiu de lucru. Scopul șinelor nu este de a glisa unitatea de pe rack. Acestea sunt destinate instalării permanente numai la punctul final de oprire și nu vor fi folosite pentru depanare și întreținere

20. Directiva DEEE

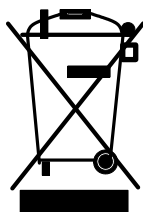

În conformitate cu Directiva DEEE 2002/96/CE, toate deșeurile de echipamente electrice și electronice (EEE) trebuie colectate separat și nu trebuie eliminate împreună cu deșeurile menajere obișnuite.

Eliminați acest produs și toate componentele sale în mod responsabil și ecologic.

E.10 Sigurnosna upozorenja za instaliranje (Croatian)

1. Upute za instaliranje



Pažljivo pročitajte upute za instaliranje prije spajanja opreme na izvor električne energije.

2. Tjelesne ozljede uslijed težine



Kako biste sigurno podignuli ovaj proizvod, koristite dovoljan broj ljudi.

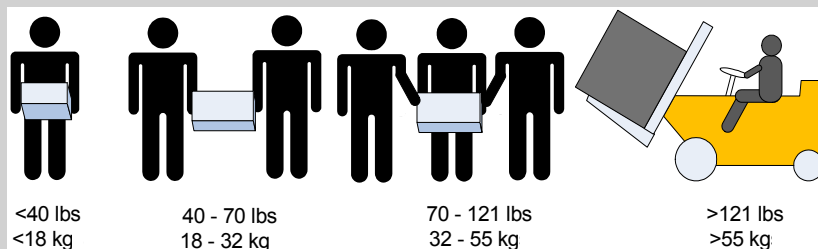

3. Teška oprema



Ova oprema je vrlo teška i treba se premještati pomoću mehaničkog dizala kako bi se izbjegle ozljede.

4. Rizik od strujnog udara!



Rizik od strujnog udara!

S uklonjenim modulom ventilatora, perima napajanja se može pristupiti u otvoru modula.

NEMOJTE umetati alat ili dijelove tijela u otvor modula ventilatora.

5. Pregrijavanje



Ovom se opremom ne bi trebalo rukovati u područjima s temperaturom okoline koja premašuje najviše preporučene vrijednosti: 45°C (113°F). Osim toga, kako bi se osigurao odgovarajući protok zraka, omogućite najmanje 8 cm (3 inča) razmaka oko otvora ventilatora.

6. Slaganje kućišta



Kućište se ne bi trebalo slagati na drugu opremu. Ako kućište padne, može izazvati tjelesne ozljede i oštećenje opreme.

7. Redundantno napajanje - Opasnost od električne energije



Ovaj proizvod uključuje redundantno napajanje ili prazan prostor na njegovu mjestu. U slučaju praznog prostora za napajanje, nemojte rukovati proizvodom ako je poklopac uklonjen ili ako nije dobro pričvršćen.

8. Višestruki ulazi za napajanje



Rizik od strujnog udara i opasnost od električne energije.
PSU jedinice su neovisne.
Odspojite sva napajanja kako biste osigurali stanje bez napajanja unutar platforme preklopnika.

9. Tijekom udara munje - Opasnost od električne energije



Tijekom djelovanja munja, nemojte raditi na opremi ili spajati ili odspajati kabele.

10. Spajanje/Odspajanje bakrenog kabela InfiniBand



Bakreni kabele InfiniBand su teški i nesavjetljivi i kao takvi se moraju pažljivo priključiti na ili isključiti iz konektora. Obratite se proizvođaču kabela za posebna upozorenja/upute.

11. Montaža ormarića i servisiranje



Kad se proizvod montira ili se servisira u ormariću, moraju se poduzeti posebne mjere opreza kako bi se osiguralo da sustav ostane stabilan. Općenito, trebali biste ispunjavati ormarić s opremom počevši od dna prema vrhu.

12. Instaliranje opreme



Ovu bi opremu trebalo instalirati, zamjenjivati i/ili servisirati samo obučeno i kvalificirano osoblje.

13. Odlaganje opreme



Odlaganje opreme trebalo bi se vršiti sukladno nacionalnim zakonima i propisima.

14. Lokalni i nacionalni električni kodovi



Ova oprema trebala bi se instalirati u skladu s lokalnim i nacionalnim električnim kodovima.

15. Instalacijski kodovi



Ovaj se uređaj mora instalirati sukladno najnovijoj verziji nacionalnih električnih kodova države. U Sjevernoj Americi oprema se mora instalirati sukladno važećim zahtjevima navedenim u US National Electrical Code i Canadian Electrical Code.

16. UL CSA kabel napajanja



Za sjevernoameričku mrežu odaberite kabel napajanja koji je na UL listi i sa CSA certifikatom, 3 - žilni, [16 AWG] (16 AWG) koji završava lijevanim utikačem nazivnog napona od 125 V, [13 A], minimalne duljine od 1,5 m [six feet] (šest stopa), ali ne dulji od 4,5 m.

Za europsku mrežu odaberite kabel napajanja koji je međunarodno usklađen i označen “<HAR>”, 3 - žilni, s najmanje 1,0 mm² žice, nazivnog napona od 300 V, s PVC izolacijom. Kabel mora imati lijevani utikač nazivnog napona od 250 V, nazivne struje od 10 A.

17. Veliko curenje struje



Upozorenje: Veliko curenje struje; Prije spajanja napajanja nužno je spojiti uzemljenje.

18. Interkonekcija uređaja



Kabli za spajanje na jedinicu RS232 i Ethernet sučelja moraju biti s UL certifikatom vrste DP-1 ili DP-2. (Napomena - kad se nalazi u krugu bez LPS vodiča)

Zaštita od strujnog preopterećenja: Uvijek dostupni odobreni zaštitni uređaji od strujnog preopterećenja nazivne struje od 20 A moraju se ugraditi u ožičenje zgrade.

19. Nemojte koristiti preklopnik kao policu ili radnu površinu



Pozor: Oprema montirana na klizače/vodilice ne bi se trebala koristiti kao policu ili radna površina. Vodilice nisu namijenjene za povlačenje uređaja iz ormarića. Služe samo za trajnu instalaciju na konačnom položaju, a ne za servisiranje i održavanje.

20. WEEE direttiva

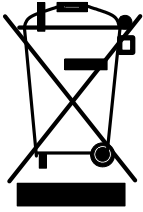

Sukladno WEEE direktivi 2002/96/EZ, sav električni i elektronički otpad (EEE) trebao bi se prikupljati zasebno i ne bi se trebao odlagati kao običan kućanski otpad. Odlaganje ovog proizvoda i svih njegovih dijelova vršite na odgovoran i ekološki način.

21. Električna ograničenja države Norveške



Ovaj je uređaj namijenjen samo za spajanje na električni sustav s TN uzemljenjem i na električni sustav s IT uzemljenjem države Norveške.

E.11 Avvertenze di sicurezza per l'installazione (italiano)

1. Istruzioni di installazione



Leggere tutte le istruzioni di installazione prima di collegare l'apparecchiatura all'alimentazione.

2. Lesioni a causa del peso



Usare un numero di persone sufficiente per sollevare in sicurezza questo prodotto.

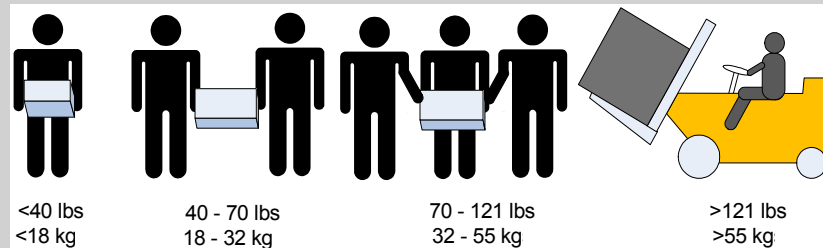

3. Apparecchiatura pesante



Questa apparecchiatura è molto pesante e va spostata mediante un sollevatore meccanico, per evitare lesioni.

4. Rischio di scosse elettriche!



Rischio di scosse elettriche!

Con il modulo ventola rimosso, i pin di alimentazione sono accessibili all'interno della cavità del modulo.

NON inserire strumenti o parti del corpo nella cavità del modulo della ventola.

5. Temperatura eccessiva



Questa apparecchiatura non va utilizzata in un'area con una temperatura ambiente

superiore a quella massima consigliata: 45 °C (113 °F). Inoltre, per assicurare un flusso d'aria adeguato, lasciare almeno 8 cm (3 pollici) di spazio attorno alle aperture di ventilazione.

6. Impilare lo chassis



Kućište se ne bi trebalo slagati na drugu opremu. Ako kućište padne, može izazvati tjelesne ozljede i oštećenje opreme.

7. Collegamento di alimentazione ridondante - Pericoli elettrici



Questo prodotto è dotato di un alimentatore ridondante o, qualora esso non sia installato, di uno spazio vuoto. Qualora l'alimentatore non sia installato, non utilizzare il prodotto con il coperchio rimosso o non fissato correttamente.

8. Prese di alimentazione multiple



Rischio e pericolo di scosse elettriche.

Gli alimentatori sono tutti indipendenti.

Scollegare tutti gli alimentatori per assicurarsi che il commutatore non sia sotto tensione

9. Durante i temporali, pericolo di scosse elettriche



Durante i temporali, non effettuare interventi sull'apparecchiatura e non collegare o scollegare i cavi.

10. Collegamento/scollegamento del cavo di rame InfiniBand



I cavi di rame InfiniBand sono pesanti e non flessibili. Di conseguenza, vanno collegati o scollegati con cura dai connettori. Per avvertenze/istruzioni speciali, rivolgersi al produttore di cavi.

11. Montaggio su rack e manutenzione



Quando questo prodotto viene montato o sottoposto a manutenzione su un rack, è necessario adottare delle precauzioni speciali per assicurarsi che il sistema resti stabile. In generale, il rack va riempito con apparecchiature, procedendo dal basso verso l'alto.

12. Installazione dell'apparecchiatura



Questa apparecchiatura va installata, sostituita e/o sottoposta a manutenzione solo da personale addestrato e qualificato.

13. Smaltimento dell'apparecchiatura



Lo smaltimento di questa apparecchiatura va effettuato in conformità con tutte le leggi e le normative nazionali.

14. Codici elettrici locali e nazionali



Questa apparecchiatura va installata in conformità con le norme elettriche locali e nazionali.

15. Codici di installazione



Questo dispositivo va installato in conformità con l'ultima versione dei codici elettrici nazionali del Paese. Per il Nord America, l'apparecchiatura va installata in conformità con i requisiti applicabili del "codice elettrico nazionale USA" e del "codice elettrico canadese".

16. Cavo di alimentazione UL e munito di certificazione CSA



Per una connessione di alimentazione nordamericana, selezionare un cavo di alimentazione di tipo UL e munito di certificazione CSA, a 3 conduttori, [16 AWG], terminato con una spina stampata con tensione nominale pari a 125 V, [13 A], di lunghezza minima pari a 1,5 m [sei piedi] ma non più lunga di 4,5 m.
Per una connessione europea, selezionare un cavo di alimentazione armonizzato a livello internazionale e contrassegnato da "<HAR>", a 3 conduttori, minimo 1,0 mm² fili, con guaina isolante in PVC. Il cavo deve disporre di una spina stampata di potenza nominale pari a 250 V, 10 A.

17. Corrente di dispersione elevata



Avvertenza: corrente di dispersione elevata; il collegamento a terra è essenziale prima di collegare l'alimentazione.

18. Interconnessione delle unità



I cavi per il collegamento all'unità RS232 e alle interfacce Ethernet devono disporre della certificazione UL ed essere del tipo DP-1 o DP-2. (Nota: in caso di installazione su un circuito la cui potenza non è limitata)

Protezione contro le sovracorrenti: la cablatura dell'edificio deve integrare un dispositivo di protezione contro le sovracorrenti di potenza nominale pari a 20.

19. Non utilizzare lo switch come scaffale o piano di lavoro



Attenzione: un'apparecchiatura scorrevole o montata su binari non va utilizzata come scaffale o piano di lavoro. I binari non sono progettati per far scorrere e allontanare l'unità dal rack. Essi sono destinati all'installazione permanente solo nel luogo di lavoro e non vengono utilizzati per assistenza e manutenzione

20. Direttiva RAEE

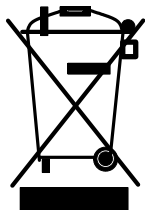

Secondo la direttiva RAEE 2002/96/EC, tutti i rifiuti da apparecchiature elettriche ed elettroniche (RAEE) vanno raccolti separatamente e non smaltiti nei normali rifiuti domestici.

Smaltire questo prodotto e tutte le sue parti in modo responsabile e rispettoso dell'ambiente

21. Limitazioni relative all'alimentazione per la Norvegia



Questa apparecchiatura è progettata esclusivamente per il collegamento a un sistema di alimentazione TN e a un sistema di alimentazione IT.

E.12 Montaj Güvenlik Uyarıları (Türkçe)

1. Montaj Talimatları



Ekipmanı güç kaynağına bağlamadan önce tüm montaj talimatlarını okuyun.

2. Ağırlık Nedeniyle Fiziksel Yaralanma



Bu ürünü güvenli bir şekilde kaldırabilmek için yeterli sayıda insandan yardım alın..

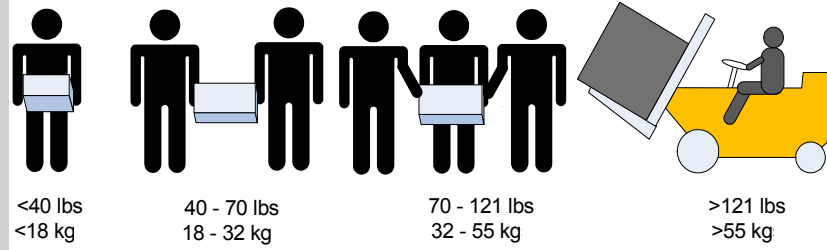

3. Ağır Ekipman



Bu ekipman çok ağırdır ve yaralanmaları önlemek için ekipmanın mekanik asansör kullanılarak taşınması gerekir.

4. Elektrik Çarpması Riski!



Bu ekipman, önerilen maksimum ortam sıcaklığını aşan alanlarda çalıştırılmamalıdır: 45 °C (113 °F). Ayrıca, düzgün hava akışı sağlamak için havalandırma deliklerinin etrafında en az 8 cm (3 inç) açıklık bırakılmalıdır.

5. Aşırı ısınma



Bu ekipman, önerilen maksimum ortam sıcaklığını aşan alanlarda çalıştırılmamalıdır: 45 °C (113 °F). Ayrıca, düzgün hava akışı sağlamak için havalandırma deliklerinin etrafında en az 8 cm (3 inç) açıklık bırakılmalıdır.

6. Şasi İstif



Şasinin diğer herhangi bir ekipmanın üzerine istiflenmemesi gerekir. Şasi düşerse, fiziksel yaralanmalara ve ekipmanda hasara neden olabilir.

7. Yedekli Güç Kaynađı Bađlantýsý -Elektrik Çarpma Tehlikesi



Bu ürün, yedekli güç kaynađı veya onun yerine boş elektrik kutusu içerir. Güç kaynađı için boş elektrik kutusu varsa, kutunun kapađı açıkken veya tam olarak kapatılmamýşken ürünü çalıřtırmayın.

8. Çoklu Güç Giriřleri



Elektrik çarpması riski ve enerji tehlikesi.
Bütün PSU'lar (Güç Kaynađı Üniteleri) ayrıdır.
Anahtar platformundaki gücü kapatmak için tüm güç kaynaklarının bađlantılarını kesin.

9. řimřek - Elektrik Çarpma Tehlikesi



Gökyüzünde řimřek çaktığı zamanlarda, ekipman üzerinde çalıřmayın veya kablo bađlamayın ya da kablo bađlantısı kesmeyin.

10. Bakır İnfıniband Kablo Bađlama/Bađlantýyı Kesme



Bakır İnfıniband kablolar ađırdır ve esnemezler. Bu nedenle, bađlantılara çok dikkatli bir şekilde takılmaları veya çıkarılmaları gerekir. Özel uyarılar/talimatlar için kablo üreticinize bařvurun.

11. İskele Montajı ve Bakım



Bu ürün bir iskelede monte edildiyse veya bir iskele ile sunulduysa, sistemin sabit kalması için özel önlemler alınmalıdır. Genelde, ekipmanları iskeleye ařađıdan yukarı doğru doldurmanız gerekir.

12. Ekipman Montajı



Ekipmanın yalnızca eđitilmiş ve nitelikli personel tarafından monte edilmesi, deđiřtirilmesi ve/veya bakımının yapılması gerekir.

13. Ekipmanın Atılması



Bu ekipmanın imhasında tüm ulusal yasalara ve düzenlemelere uyulması gerekir.

14. Yerel ve Ulusal Elektrik Kodları



Bu ekipmanın montajında yerel ve ulusal elektrik kodlarına uyulması gerekir.

15. Montaj Kodları



Bu cihazın, ülke ulusal elektrik kodlarının son sürümüne göre monte edilmesi gerekir. Kuzey Amerika için, ekipmanın ABD Ulusal Elektrik Kodu ve Kanada Elektrik Kodu'nun uygulama koşullarına göre monte edilmesi gerekir.

16. UL Kayıtlı ve CSA Onaylı Güç Kaynağı Kablosu



Kuzey Amerika'da güç bağlantısı için, UL Kayıtlı ve CSA Onaylı bir güç kaynağı kablosu seçin, 3 - iletken, [16 AWG], 125 V değerinde, kalıplanmış bir fişle biten, [13 A], en az 1,5 m (altı fit) uzunluğunda fakat 4,5 m'den uzun olmayan bir kablo. Avrupa'da güç bağlantısı için, uluslararası uyumlu ve “<HAR>” işaretli, 3 - iletken, en az 1,0 mm² tel, 300 V değerinde ve PVC yalıtımlı bir güç kaynağı kablosu seçin. Kablonun 250 V, 10 A değerinde bir kalıplanmış fişi olması gerekmektedir.

17. Yüksek Kaçak Akım



Uyarı: Yüksek kaçak akım varsa; güç kaynağına bağlanmadan önce mutlaka topraklama bağlantısı yapılmalıdır.

18. Ünitelerin Ara Bağlantısı



RS232 ünitesini ve Ethernet Arabirimlerini bağlayacak olan kabloların UL onaylı DP-1 veya DP-2 tipi olması gerekir. (Not- LPS olmayan devreye aitse) Aşırı Akım Koruması: Kolayca erişilebilecek 20 V Kayıtlı devre parçası aşırı akım koruma cihazının bina elektrik şebekesinde kurulu olması gerekir.

19. Anahtarı Raf veya Çalışma Alanı olarak kullanmayın!

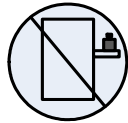

Dikkat: Sürgülü/raylı ekipman raf veya çalışma alanı olarak kullanılamaz. Raylar üniteyi iskeleden uzağa kaydırmak için yapılmamıştır. Sadece, ekipmanın son olarak duracağı yerdeki kalıcı montaj içindir, servis veya bakım için kullanılamaz.

20. WEEE Yönergesi

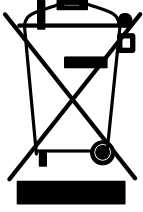

WEEE Yönergesi 2002/96/EC uyarınca, tüm elektrikli ve elektronik ekipman atıkları (EEE) ayrı olarak toplanmalı ve evsel atıklarla birlikte çöpe atılmamalıdır. Bu ürün ve tüm parçaları çevreye dost ve sorumlu bir şekilde imha edilmelidir.

21. Norveç Güç Kısıtlamaları



Bu ünite, bir TN güç sistemine ve sadece Norveç'in IT güç sistemine bağlanmak içindir.

22. Japan VCCI Statement

この装置は、クラス A 情報技術装置です。この装置を家庭環境で使用すると電波妨害を引き起こすことがあります。この場合には使用者が適切な対策を講ずるよう要求されることがあります。

VCCI-A