

AXL AI 8 (-ME)

**Axioline analog input module, 8 inputs,
2-wire connection method**

AUTOMATION



1 Description

The module is designed for use within an Axioline station.
It is used to acquire analog voltage and current signals.

Features

- Eight analog, bipolar input channels to connect either voltage or current signals
- Connection of sensors in 2-wire technology
- Voltage ranges: 0 V ... 10 V, ± 10 V, 0 V ... 5 V, ± 5 V
- Current ranges: 0 mA ... 20 mA, 4 mA ... 20 mA, ± 20 mA
- Device type label stored
- Status and diagnostic indicators



This data sheet is only valid in association with the UM EN AXL SYS INST user manual.

2	Table of contents	
1	Description	1
2	Table of contents	2
3	Ordering data	3
4	Technical data	3
5	Tolerance data.....	6
6	Internal circuit diagram	7
7	Terminal point assignment.....	7
8	Connection examples	8
9	Connection notes	8
10	Local status and diagnostic indicators	9
11	Process data.....	10
12	Significant values in various formats.....	11
	12.1 Significant values in "IB IL" format	11
	12.2 Significant values in S7-compatible format	11
	12.3 Calculation of the measured value from the process data input value	12
13	Parameter, diagnostics and information (PDI)	12
14	Standard objects	13
	14.1 Objects for identification (device rating plate).....	13
	14.2 Object descriptions	14
	14.3 Diagnostics objects	15
	14.4 Objects for process data management.....	16
15	Application objects	17
	15.1 Parameter table (0080hex: ParaTable).....	17
	15.2 Measured value in extended float format (0082hex: Measured Value Float)	18
16	Device descriptions	18

3 Ordering data

Description	Type	Order No.	Pcs./Pkt.
Axioline analog input module, 8 inputs: 0 - 10 V, ±10 V, 0 - 20 mA, 4 - 20 mA, ±20 mA, 2-wire connection method (including bus base module and connector)	AXL AI 8	2688064	1
Axioline analog output module, 8 inputs: 0 - 10 V, ±10 V, 0 - 20 mA, 4 - 20 mA, ±20 mA, 2-wire connection method (electronic module as a replacement for item 2688064 AXL AI 8)	AXL AI 8-ME	2688187	1
Accessories	Type	Order No.	Pcs./Pkt.
Axioline bus base module (Replacement item)	AXL BS	2688129	5
Axioline shield connection set (contains 2 busbar holders and 2 SK 5 shield connection clamps)	AXL SHIELD SET	2700518	1
Zack marker strip for Axioline (device labeling), in 2 x 20.3 mm pitch, unprinted, 25-section, for individual labeling with B-STIFT 0.8, X-PEN, or CMS-P1-PLOTTER (Marking)	ZB 20,3 AXL UNPRINTED	0829579	25
Zack marker strip flat for Axioline (connector/slot labeling), in 1 x 5.8 mm + 4 x 10.0 mm pitch, unprinted, 50-section, for individual labeling with B-STIFT 0.8, X-PEN, or CMS-P1-PLOTTER (Marking)	ZBF 10/5,8 AXL UNPRINTED	0829580	50
Documentation	Type	Order No.	Pcs./Pkt.
User manual, English, Axioline: System and installation	UM EN AXL SYS INST	-	-

4 Technical data

Dimensions (nominal sizes in mm)

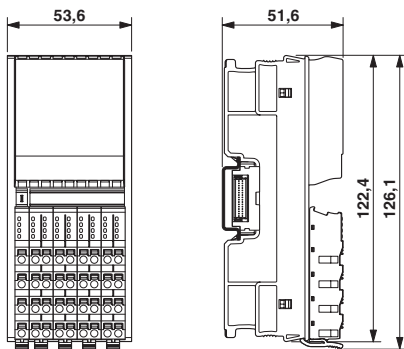

Width	53.6 mm
Height	126.1 mm
Depth	51.6 mm
Note on dimensions	The depth is valid when a TH 35-7.5 DIN rail is used (according to EN 60715).

General data

Color	Gray
Weight	204 g
Ambient temperature (operation)	-25 °C ... 60 °C
Ambient temperature (storage/transport)	-40 °C ... 70 °C
Permissible humidity (operation)	5 % ... 95 % (according to DIN EN 61131-2)
Permissible humidity (storage/transport)	5 % ... 95 % (according to DIN EN 61131-2)

General data

Air pressure (operation)	70 kPa ... 106 kPa (up to 3000 m above sea level)
Air pressure (storage/transport)	70 kPa ... 106 kPa (up to 3000 m above sea level)
Degree of protection	IP20
Protection class	III, IEC 61140, EN 61140, VDE 0140-1

Connection data

Type of connection	Spring-cage connection with direct plug-in method
Conductor cross section, solid	0.2 mm ² ... 1.5 mm ²
Conductor cross section, stranded	0.2 mm ² ... 1.5 mm ²
Conductor cross section [AWG]	24 ... 16

Interface Axio bus

Type of connection	Bus base module
Transmission speed	100 Mbps

Communications power

Communications power U_{bus}	5 V DC (via bus base module)
Current consumption from U_{bus}	Typ. 105 mA , max. 130 mA

I/O supply

Supply of analog modules U_A	24 V DC
Maximum permissible voltage range	19.2 V DC ... 30 V DC (including all tolerances, including ripple)
Current consumption from U_A	Typ. 35 mA , max. 45 mA
Surge protection	Electronic (35 V, 0.5 s)
Protection against polarity reversal	Polarity protection diode
Transient protection	Suppressor diode

Analog inputs

Number of inputs	max. 8 (differential inputs, voltage or current can be chosen separately)
Type of connection	Spring-cage connection with direct plug-in method
Connection method	2-wire (shielded, twisted pair)
Current input signal	0 mA ... 20 mA , 4 mA ... 20 mA , -20 mA ... 20 mA
Voltage input signal	0 V ... 5 V , -5 V ... 5 V , 0 V ... 10 V , -10 V ... 10 V
Resolution A/D	16 bits
A/D conversion time	2 μ s
Limit frequency (3 dB)	30 Hz , 12 kHz (in fast mode)
Measured value representation	16 bits (15 bits + sign bit)
Data formats	IB IL, S7-compatible
Process data update	300 μ s
Filtering	RFI filtering / passive TP 1st order
Input filter	30 Hz, 12 kHz and mean-value generation (can be parameterized)
Precision	0.1 % (of measuring range final value for active mean-value generation and 30 Hz filter)
Transient protection of inputs	Suppressor diode

differential inputs, voltage

Number of inputs	8 (differential inputs, voltage)
Voltage input signal	0 V ... 5 V , -5 V ... 5 V , 0 V ... 10 V , -10 V ... 10 V
Input resistance of voltage input	268 k Ω (typical)

differential inputs, voltage

Open circuit response	Goes to 0 V
Common mode voltage range signal - ground	-50 V DC ... 50 V DC
Overload protection	±30 V DC, maximum

differential inputs, current

Number of inputs	8 (differential inputs, current)
Current input signal	0 mA ... 20 mA , 4 mA ... 20 mA , -20 mA ... 20 mA
Input resistance current input	104 Ω (typical)
Open circuit response	Going to 0 mA; open-circuit detection from 4 mA ... 20 mA
Overload protection	No; ±5.2 V DC, maximum, I _{max} = 50 mA

Electrical isolation/isolation of the voltage areas

5 V communications power (logic), 24 V supply (I/O)	500 V AC , 50 Hz , 1 min
5 V supply (logic)/functional earth ground	500 V AC , 50 Hz , 1 min
24 V supply (I/O) / functional earth ground	500 V AC , 50 Hz , 1 min

Mechanical tests

Vibration resistance in acc. with IEC 60068-2-6	5 g
Shock test in acc. with IEC 60068-2-27	25 g, 11 ms period, half-sine shock pulse
Bump endurance test according to EN 60068-2-29	10 g

Conformance with EMC Directive 2004/108/EC

Noise immunity test in accordance with EN 61000-6-2

Electrostatic discharge (ESD) EN 61000-4-2/IEC 61000-4-2	Criterion B; 6 kV contact discharge, 8 kV air discharge
Electromagnetic fields EN 61000-4-3/IEC 61000-4-3	Criterion A; Field intensity: 10 V/m
Fast transients (burst) EN 61000-4-4/IEC 61000-4-4	Criterion B, 2 kV
Transient surge voltage (surge) EN 61000-4-5/IEC 61000-4-5	Criterion B; supply lines DC: ±0.5 kV/±0.5 kV (symmetrical/asymmetrical); ±1 kV to shielded I/O cables
Conducted interference EN 61000-4-6/IEC 61000-4-6	Criterion A; Test voltage 10 V

Noise emission test according to EN 61000-6-3

Radio interference properties EN 55022	Class B
--	---------

Approvals

For the latest approvals, please visit www.phoenixcontact.net/catalog.

5 Tolerance data

The following applies for tolerance values:

The data is valid for nominal operation ($U_A = 24\text{ V}$ in the default configuration (unless documented otherwise).

Default configuration: Filter with 30 Hz, 16-sample mean-value, IB IL format.

300 μs update time, fast mode (12 kHz filter, without mean-value generation)

Tolerances at $T_A = 25^\circ\text{C}$				
	Absolute		Relative	
	Typ.	Max.	Typ.	Max.
0 V ... 5 V, $\pm 5\text{ V}$, 0 V ... 10 V, $\pm 10\text{ V}$	$\pm 50\text{ mV}$	$\pm 80\text{ mV}$	$\pm 0.5\%$	$\pm 0.8\%$
0 mA ... 20 mA, 4 mA ... 20 mA, $\pm 20\text{ mA}$	$\pm 100\text{ }\mu\text{A}$	$\pm 160\text{ }\mu\text{A}$	$\pm 0.5\%$	$\pm 0.8\%$

300 μs update time, default (30 Hz filter, 16-sample average value)

Tolerances at $T_A = 25^\circ\text{C}$				
	Absolute		Relative	
	Typ.	Max.	Typ.	Max.
0 V ... 5 V, $\pm 5\text{ V}$, 0 V ... 10 V, $\pm 10\text{ V}$	$\pm 10\text{ mV}$	$\pm 30\text{ mV}$	$\pm 0.10\%$	$\pm 0.30\%$
0 mA ... 20 mA, 4 mA ... 20 mA, $\pm 20\text{ mA}$	$\pm 20\text{ }\mu\text{A}$	$\pm 60\text{ }\mu\text{A}$	$\pm 0.10\%$	$\pm 0.30\%$

Typical data contains offset error, gain error, and linearity error in the respective default setting.

All tolerances indicated as a percentage are related to the positive measuring range final value.

Please also observe the values for temperature drift and the tolerances under influences of electromagnetic interferences.

Tolerance and temperature response at $T_A = -25^\circ\text{C}$ to $+60^\circ\text{C}$		
	Drift	
	Typical	Maximum
0 V ... 5 V, $\pm 5\text{ V}$, 0 V ... 10 V, $\pm 10\text{ V}$	$\pm 40\text{ ppm/K}$	$\pm 70\text{ ppm/K}$
0 mA ... 20 mA, 4 mA ... 20 mA, $\pm 20\text{ mA}$	$\pm 45\text{ ppm/K}$	$\pm 85\text{ ppm/K}$

The drift values refer to the relevant measuring range final value.

Tolerances influenced by electromagnetic interference

		Current	Voltage
Electromagnetic fields	EN 61000-4-3/ IEC 61000-4-3	$< \pm 1.0\%$	$< \pm 2.0\%$
Fast transients (burst)	EN 61000-4-4/ IEC 61000-4-4	$< \pm 1.0\%$	$< \pm 1.0\%$
Conducted interference	EN 61000-4-6/ IEC 61000-4-6	$< \pm 0.5\%$	$< \pm 0.5\%$

Additional tolerances may occur due to the influence of high-frequency electromagnetic interference caused by wireless transmission systems in the near vicinity. The values specified refer to nominal operation in the event of direct interference to components without additional shielding such as a steel cabinet, etc.

The above mentioned tolerances can be reduced by providing further shielding measures for the I/O module (e.g., use of a shielded control box/control cabinet, etc.).

6 Internal circuit diagram



Bild 1 Internal wiring of the terminal points

Key:



7 Terminal point assignment

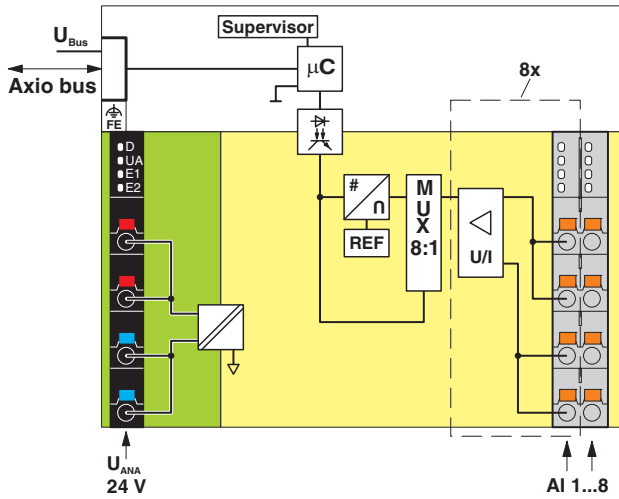
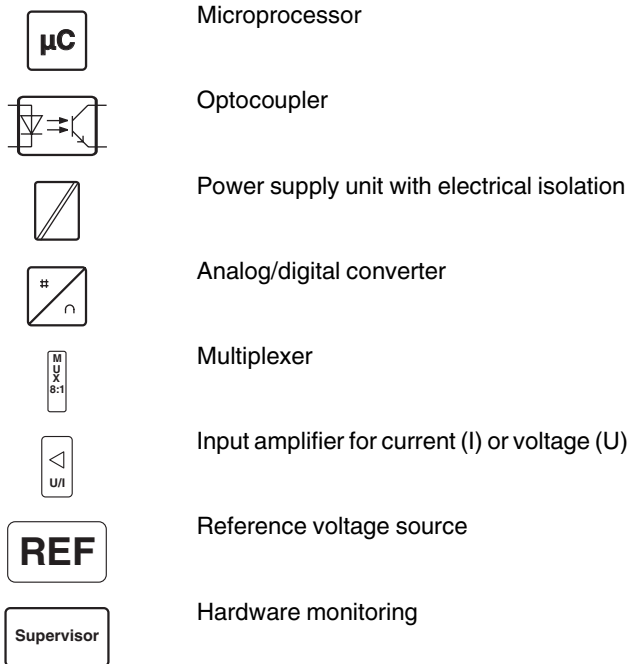

Bild 2 Terminal point assignment

Terminal point	Color	Assignment	
Supply voltage input			
a1, a2	Red	24 V DC (U _A)	Supply of analog modules (internally connected)
b1, b2	Blue	GND	Reference potential of the supply voltage (internally connected)
Analog inputs			
00 ... 07	Orange	U1+ ... U8+	Positive voltage connection for channels 1 ... 8
10 ... 17	Orange	U1- ... U8-	Negative voltage connection for channels 1 ... 8
20 ... 27	Orange	I1+ ... I8+	Positive current connection for channels 1 ... 8
30 ... 37	Orange	I1- ... I8-	Negative current connection for channels 1 ... 8

8 Connection examples

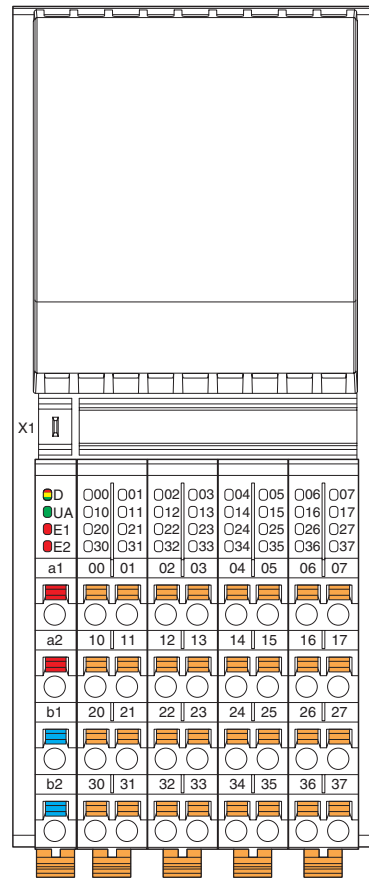

Bild 3 Connection for voltage and current measurement



Bild 4 Connection of potentiometric position sensors

The values of potentiometric position sensors can be acquired with voltage measurement. Supply the potentiometer via an external power supply unit ($U_{\text{ext}} = 10 \text{ V}$).

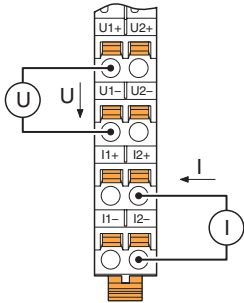

Bild 5 Passive pressure sensor at a differential current input

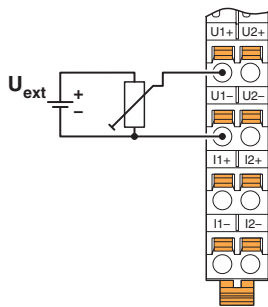

Bild 6 Differential voltage input with active 3-wire transmitter

9 Connection notes

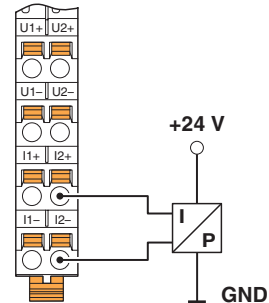
Always connect the analog sensors using shielded, twisted pair cables.

Unshielded cables may be out of the specified tolerances in environments with heavy noise.

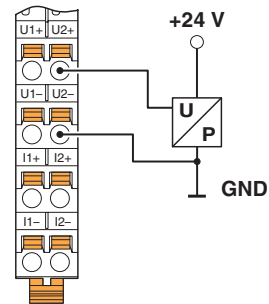
Connect the cable shield to functional earth ground, immediately when the cables enter the control cabinet.

If there is no closed control cabinet, connect the shield to a shield bus.



For further information on shielding, please refer to the UM EN AXL SYS INST user manual.

10 Local status and diagnostic indicators



Bild 7 Local status and diagnostic indicators

Designation	Color	Meaning	State	Description
D	Red/ yellow/ green	Diagnostics of local bus communication		
		Power down	OFF	Device in (power) reset
		Not connected	Red flashing	Device operating, but there is no connection to previous device.
		Reset	Red ON	Application reset Device operating, but there is still a connection to the previous device, the application is reset.
		Ready	Yellow ON	Device operating, there is still a connection to the previous device, but the device has not yet detected a valid cycle after power on.
		Connected	Yellow flashing	Valid data cycles have been detected, but the device is (not) yet part of the current configuration.
		Device application not ready	Green/yellow alternating	Valid data cycles are being detected. The master application set the output data to valid, however, the slave application has not set the input data to valid as yet.
		Active	Green flashing	Device operating, communications within the Axioline station is OK. The master application does not read the input data. (The connection to the controller has not yet been established, for example)
Run	Green ON	Valid data cycles are being detected. All data is valid		
UA	Green	U _{Analog}	ON	Supply of analog modules present
			OFF	Supply of analog modules not present
E1	Red	Peripheral fault	ON	I/O error present
			OFF	No I/O error
E2	Red	Channel error	ON	Channel error present
			OFF	Channel error not present



Channel errors are errors that can be associated with a channel.
Periphery errors are errors that affect the entire module.

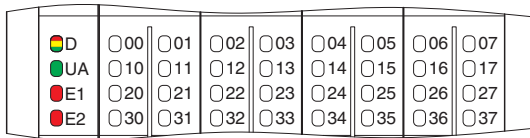

For more information on the meaning of local diagnostic and status indicators, please refer to the UM EN AXL SYS INST user manual.

Error code and status of the E1 and E2 LEDs

Error	E1 LED	E2 LED
No error	OFF	OFF
Underrange	OFF	ON
Overrange	OFF	ON
Open circuit	OFF	ON
Faulty supply voltage	ON	ON
Parameter table invalid	OFF	ON
Device error	OFF	ON
Flash format error	OFF	ON



The error that can actually be reported depends on the measuring range. For additional information please refer to the tables with significant measured values in various formats.

11 Process data

The module uses eight input process data words. Each channel is mapped to a word.

Input words IN1 to IN8

The measured values are transmitted to the controller board or the computer by means of the IN process data words IN1 to IN8.

The measured values are depicted in IB IL or S7-compatible format. In both cases, the measured value is displayed in 16 bit format. The data type is Integer 16 from a technical programming point of view.

15	14	13	12	11	10	9	8	7	6	5	4	3	2	1	0
Analog value															

In the IB IL format a diagnostic code is mapped to the input data in the event of an error.

Code (hex)	Cause
8001	Measuring range exceeded (overrange)
8002	Open circuit
8004	Measured value invalid/no valid measured value available
8020	Faulty supply voltage
8040	Device faulty
8080	Below measuring range (underrange)

12 Significant values in various formats

12.1 Significant values in "IB IL" format

Input data		0 V ... 10 V	± 10 V	0 V ... 5 V	± 5 V	0 mA ... 20 mA	± 20 mA	4 mA ... 20 mA
hex	dec	SB	SB	SB	SB	mA	mA	mA
8001	Overrange	> +10.837	> +10.837	> +5.419	> +5.419	> +21.6747	> +21.6747	> +21.3397
7F00	32512	+10.837	+10.837	+5.419	+5.419	+21.6747	+21.6747	+21.3397
7530	30000	+10.0	+10.0	+5.0	+5.0	+20.0	+20.0	+20.0
0001	1	+333.33 µV	+333.33 µV	+166.67 µV	+166.67 µV	+0.6667 µA	+0.6667 µA	+4.0005333
0000	0	≤ 0	0	≤ 0	0	≤ 0	0	+4.0 ... +3.2
FFFF	-1		-333.33 µV		-166.67 µV		-0.6667 µA	
8AD0	-30000		-10.0		-5.0		-20.0	
8100	-32512		-10.837		-5.419		-21.6747	
8080	Underrange		< -10.837		< -5.419		< -21.6747	
8002	Open circuit							< +3.2

The maximum measured value is 7F00_{hex}.

Depending on the format, the minimum measured value is either 0000_{hex} or 8100_{hex}.

12.2 Significant values in S7-compatible format

Input data		0 V ... 10 V	± 10 V	0 V ... 5 V	± 5 V	0 mA ... 20 mA	± 20 mA	4 mA ... 20 mA
hex	dec	SB	SB	SB	SB	mA	mA	mA
7FFF	Overrange	> +11.759	> +11.759	> +5.879	> +5.879	> +23.5157	> +23.5157	> +22.8142
7EFF	32511	+11.759	+11.759	+5.879	+5.879	+23.5157	+23.5157	+22.8142
6C00	27648	+10.0	+10.0	+5.0	+5.0	+20.0	+20.0	+20.0
0001	1	+361.69 µV	+361.69 µV	+180.85 µV	+180.85 µV	+0.7234 µA	+0.7234 µA	+4.0005787
0000	0	≤ 0	0	≤ 0	0	≤ 0	0	+4.0
FFFF	-1		-361.69 µV		-180.85 µV		-0.7234 µA	+3.9994
F940	-1728		-0.625		-0.3125		-1.25	+3.0
9400	-27648		-10.0		-5.0		-20.0	
8100	-32512		-11.759		-5.879		-23.5157	
8000	Under-range/open circuit		< -11.759		< -5.879		< -23.5157	< +1.1852

The maximum measured value is 7EFF_{hex}.

Depending on the format, the minimum measured value is either 0000_{hex} or 8100_{hex}.

12.3 Calculation of the measured value from the process data input value

The following examples explain the calculation of the measured value from the process data input value for the measuring range 4 mA to 20 mA.

PD IW = Process data input word = input data

IB IL format

$$\text{Resolution} = (20 \text{ mA} - 4 \text{ mA}) / 30000 = 0.0005333$$

$$\text{Measured value} = \text{PD-EW} \times 0.0005333 \text{ mA} + 4 \text{ mA}$$

Example 1

PD IW $493F_{\text{hex}} = 18751_{\text{dec}}$
 Value x resolution $18751 \times 0.000533 \text{ mA} = 10 \text{ mA}$
 + 4 mA $10 \text{ mA} + 4 \text{ mA} = 14 \text{ mA}$
 Measured value 14 mA

S7-compatible format

$$\text{Resolution} = (20 \text{ mA} - 4 \text{ mA}) / 27648 = 0.0005787$$

$$\text{Measured value} = \text{PD IW} \times 0.0005787 \text{ mA} + 4 \text{ mA}$$

Example 1

PD IW $6C00_{\text{hex}} = 27648_{\text{dec}}$
 Value x resolution $27648 \times 0.0005787 \text{ mA} = 16 \text{ mA}$
 + 4 mA $16 \text{ mA} + 4 \text{ mA} = 20 \text{ mA}$
 Measured value 20 mA

Example 2

PD IW $F940_{\text{hex}} \rightarrow FFFF_{\text{hex}} - F940_{\text{hex}} + 1 = -1728_{\text{dec}}$
 Value x resolution $-1728 \times 0.0005787 \text{ mA} = -1 \text{ mA}$
 + 4 mA $-1 \text{ mA} + 4 \text{ mA} = 3 \text{ mA}$
 Measured value 3 mA

13 Parameter, diagnostics and information (PDI)

Parameter and diagnostic data as well as other information is transmitted via the PDI channel.



For information on PDI, please refer to the UM EN AXL SYS PRO user manual.

The standard and application objects stored in the module are described in the following section.

The following applies to all tables below:

Please refer to the UM DE AXL SYS PRO User Manual or the basic profile for an explanation of the object codes and data types.

Abbreviation	Meaning
A	Number of elements
L	Length of the elements
R	Read
C	Write

14 Standard objects



Please refer to the basic profile for comprehensive information.

14.1 Objects for identification (device rating plate)

Index [hex]	Object name	Object code	Data type	A	L	Rights	Meaning	Contents
Manufacturer								
0001	VendorName	Var	Visible String	1	16	R	Manufacturer name	Phoenix Contact
0002	VendorID	Var	Visible String	1	7	R	Manufacturer identification	00A045
0003	VendorText	Var	Visible String	1	49	R	Comment on the manufacturer	Components and systems for industrial automation
0012	VendorURL	Var	Visible String	1	30	R	URL of the manufacturer	http://www.phoenixcontact.com
Module - special								
0007	ProductName	Var	Visible String	1	12	R	Product designation	AXL AI 8-ME
0008	SerialNo	Var	Visible String	1	11	R	Serial number	xxxxxxxxxx (e. g., 12345123456)
0009	ProductText	Var	Visible String	1	24	R	Product text	8 analog input channels
000A	OrderNumber	Var	Visible String	1	8	R	2688187	Order No.
0037	DeviceType	Var	Octet string	1	8	R	Module identification	00 20 00 10 00 00 00 A0 _{hex}
000B	HardwareVersion	Record	Visible String	2	14	R	Hardware version	e. g., 2010-06-21; 01
000C	FirmwareVersion	Record	Visible String	2	16	R	Firmware version	e. g., 2010-06-21; V1.10
000D	PCH version	Record	Visible String	2	24	R	Parameter channel version	e. g., 2010-01-08; V1.00
0006	ProductFamily	Var	Visible String	1	3	R	Product family	Axioline - High speed I/O system

Index [hex]	Object name	Object code	Data type	A	L	Rights	Meaning	Contents
Module - general								
0004	DeviceFamily	Var	Visible String	1	14	R	Device family	I/O analog IN
000E	CommProfile	Var	Visible String	1	4	R	Communication profile	633
000F	DeviceProfile	Var	Visible String	1	5	R	Device profile	0010
0011	ProfileVersion	Record	Visible String	2	33	R	Device profile version	2009-10-22; Basic - Profile V1.12
0013	DeviceDescFile	Var	Visible String	1	28	R	File name of the FDCML device description file	AXL_AI_8- ME_dtmv00_1.00 .xml
003A	VersionCount	Array	Unsigned 16	4	2	R	Version counter	e. g., 0005 0000 0000 0000
0017	Language	Record	Visible String	2	14	R	Language	en-us; English
Use of the device								
0014	Location	Var	Visible String	1	59	R/W	Installation location	Please fill in ...
0015	EquipmentIdent	Var	Visible String	1	59	R/W	Equipment identifier	Please fill in ...
0016	ApplDeviceAddr	Var	Unsigned 16	1	2	R/W	User-defined device number	xx xx _{hex} (e. g., 00 01)

14.2 Object descriptions

Index [hex]	Object name	Object code	Data type	A	L	Rights	Meaning
0038	ObjDescrReq	Record		2	3	Read, write	Object whose description is requested
0039	ObjDescr	Record		16	See sub-indices	Read	Description of the object whose index was requested
003B	PDIN_Descr	Record		3	12	R	Description of the IN process data
003C	PDOOUT_Descr	Record		3	12	R	Description of the output process data



These objects are only important for tools and are therefore not described in more detail here. Please refer to the basic profile for comprehensive information.

14.3 Diagnostics objects

Index [hex]	Object name	Object code	Data type	A	L	Rights	Assignment
0018	DiagState	Record		6	21	R	Diagnostic state
0019	ResetDiag	Var	Unsigned 8	1	1	C	Reset diagnostics

Diagnostics state (0018_{hex}: DiagState)

This object is used for a structured message of an error.

0018 _{hex} : DiagState (Read)					
Subindex	Data type	Length in bytes	Meaning	Contents	
0	Record	21	Diagnostic state	Complete diagnostics information	
1	Unsigned 16	2	Error number	0 ... 65535 _{dec}	
2	Unsigned 8	1	Priority	00 _{hex}	No error
				01 _{hex}	Error
				02 _{hex}	Warning
				81 _{hex}	Error removed
				82 _{hex}	Warning eliminated
3	Unsigned 8	1	Channel	00 _{hex}	No error
				01 _{hex}	Channel 1
				:	:
				08 _{hex}	Channel 8
				FF _{hex}	Entire device
4	Unsigned 16	2	Error code	See table below	
5	Unsigned 8	1	More follows	00 _{hex} (not supported)	
6	Visible String	14	Text (14 characters)	See table below	



The message with the priority 81_{hex} or 82_{hex} is a one-time internal message to the bus coupler that is implemented onto the error mechanisms of the higher-level system by the bus coupler.

Error code and associated text

Error	Error code	Text	Priority	Channel
No error	0000 _{hex}	Status OK	00 _{hex}	00 _{hex}
Underrange	8920 _{hex}	Underrange	02 _{hex}	01 _{hex} ... 08 _{hex}
Overrange	8910 _{hex}	Overrange	02 _{hex}	01 _{hex} ... 08 _{hex}
Open circuit	7710 _{hex}	Open circuit	01 _{hex}	01 _{hex} ... 08 _{hex}
Faulty supply voltage	5160 _{hex}	Supply fail	01 _{hex}	FF _{hex}
Parameter table invalid	6320 _{hex}	Invalid para	01 _{hex}	FF _{hex}
Device error	6301 _{hex}	CS FLASH	01 _{hex}	FF _{hex}
Flash format error	6302 _{hex}	FO FLASH	01 _{hex}	FF _{hex}

Reset diagnostics (0019_{hex}: ResetDiag)

You can delete the diagnostics memory and acknowledge the diagnostic messages with this object.

0019 _{hex} : ResetDiag (Write)					
Subindex	Data type	Length in bytes	Meaning	Contents	
0	Unsigned 8	1	Reset diagnostics	00 _{hex}	No action
				02 _{hex}	Deletes and acknowledges all pending malfunctions that not been read out
				06 _{hex}	Deletes and acknowledges the entire diagnostics and allows no further diagnostic messages
				Other	Reserved

14.4 Objects for process data management

Index [hex]	Object name	Object code	Data type	A	L	Rights	Assignment
0025	PDIN	Var	Octet string	1	16	R	IN Process Data
0026	PDOUT	Var	Octet string	1	16	R	OUT process data; not applicable

IN process data (0025_{hex}: PDIN)

You can read the IN process data of the module with this object.

0025 _{hex} : PDIN (Read)					
Subindex	Data type	Length in bytes	Meaning	Contents	
0	Octet string	16	IN Process Data	The structure corresponds to the representation in the "Process data" section.	

15 Application objects

Index [hex]	Object name	Object code	Data type	A	L	Rights	Assignment
0080	ParaTable	Array	Unsigned 16	10	10 * 2	R/W	Parameter table
0082	Measured Value Float	Array	Octet string	8	8 * 6	R	Measured values in the extended float format

15.1 Parameter table (0080_{hex}: ParaTable)

Parameterize the module using this object.

The parameterization is permanently stored on the module.

After resetting, the module works with the last permanently stored data. If no permanent data was stored, the module works with the default data.

0080 _{hex} : ParaTable (read, write)				
Subindex	Data type	Length in bytes	Meaning	Default value
0	Array of Unsigned 16	10 * 2	Read/write all elements	See subindices
1	Unsigned 16	2	Parameterization of channel 1	0000 _{hex}
:	Unsigned 16	2	:	0000 _{hex}
8	Unsigned 16	2	Parameterization of channel 8	0000 _{hex}
9	Unsigned 16	2	Data format	0000 _{hex}
10	Unsigned 16	2	Reserved	0000 _{hex}

Parameterization of channel 1 ... channel 8

Parameterization word:

15	14	13	12	11	10	9	8	7	6	5	4	3	2	1	0
0	0	0	Filter	0	0	Mean-value	0	0	0	0	0	Measuring range			

Filter	Code (bin)
30 Hz (default)	0
12 kHz	1

Measuring range	Code (bin)
0 V ... 10 V (default)	0000
±10 V	0001
0 V ... 5 V	0010
±5 V	0011
0 mA ... 20 mA	0100
±20 mA	0101
4 mA ... 20 mA	0110
Reserved	0111 ... 1110
Channel inactive	1111

Mean-value	Code (bin)
16-sample (default)	00
No mean-value	01
4-sample	10
32-sample	11

Data format:

15	14	13	12	11	10	9	8	7	6	5	4	3	2	1	0
0	0	0	0	0	0	0	Data format	0	0	0	0	0	0	0	0

Data format	Code (bin)
IB IL (default setting)	00
Reserved	01
S7-compatible	10
Reserved	11

15.2 Measured value in extended float format (0082_{hex}: Measured Value Float)

You can read the IN process data in Inline or S7-compatible format with the 0025_{hex} object.

The 0082_{hex} object is also available.

This object provides the measured value in the highest internal accuracy of the terminal in the float format.

0082 _{hex} : Measured Value Float (Read)			
Subindex	Data type	Length in bytes	Meaning
0	Array of Octet Strings	8 * 6	Read all elements
1	Octet string	6	Measured value for channel 1
:	:	:	:
8	Octet string	6	Measured value for channel 8

channel 1 ... channel 8 measured value

Element	Data type	Length in bytes	Meaning
1	Float 32	4	Value in the float format acc. to IEEE 754
2	Unsigned 8	1	Status
3	Unsigned 8	1	Unit code

Structure of the float format according to IEEE 754 in the bit representation:

VEEE EEEE	EMMM MMMM	MMMM MMMM	MMMM MMMM
-----------	-----------	-----------	-----------

- SB 1 sign bit, 0: positive, 1: negative
- E 8 bits exponent with offset 7F_{hex}
- M 23 bits mantissa

Some example values for conversion from floating point to hexadecimal representation:

Floating point	Hexadecimal representation
1.0	3F 80 00 00
10.0	41 20 00 00
1.03965528	3F 85 13 6
- 1.0	BF 80 00 00

Extended Float Format

The Extended Float Format is a specially defined format. It consists of the measured value in the float format, a status and a unit code.

Status is necessary because the float format defines no patterns providing information on the status of the numerical value.

Status corresponds to the LSB of the Inline diagnostic codes (e.g. overrange: Status = 01, Inline diagnostic code = 8001_{hex}). If Status = 0, the measured value is valid.

Unit code	Code
Volt (V)	58 (3A _{hex})
Milliampere (mA)	39 (27 _{hex})

Status	Code
Measured value is valid	00 _{hex}
Measured value is invalid	Other

16 Device descriptions

The device is described in the FDCML files (PC WORX) or GSDML files (S7 Hardware configurator). The files can be found at the bus coupler and can be downloaded at www.phoenixcontact.net/download.