

# **CASTLE, INC MORTISE MACHINE MODEL TSM-20**

## **OPERATOR'S MANUAL Addendum**

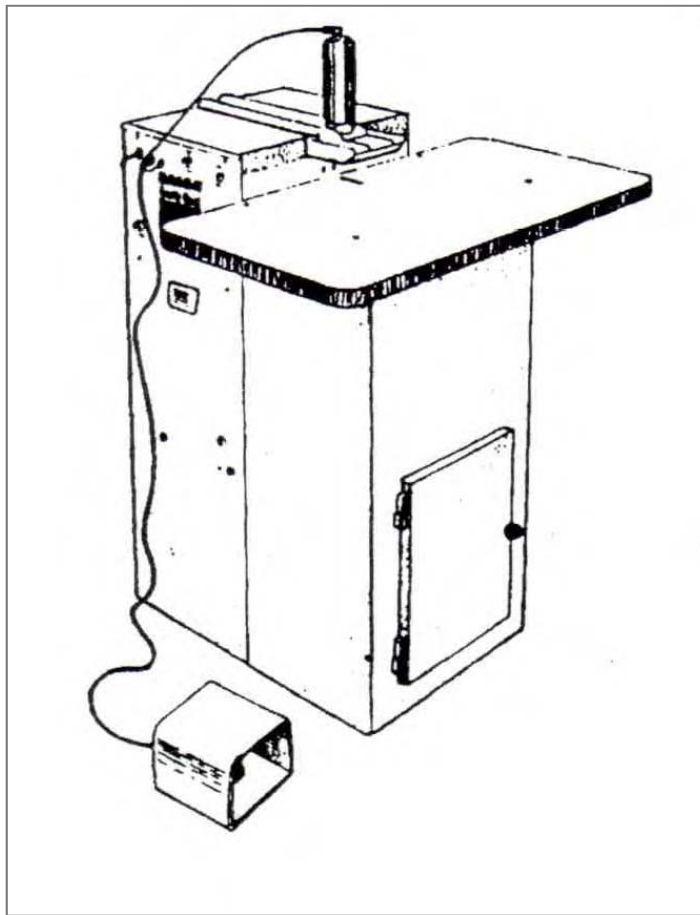

*Revised: December 16, 2010 (rev 2)*

---

**CASTLE, INC.  
MORTISE MACHINE MODEL TSM-20  
OPERATOR'S MANUAL  
ADDENDUM**

**TABLE OF CONTENTS**

	<u>Page #</u>
<i>1.0 SAFETY SWITCH CHECK.....</i>	<i>1</i>
<i>2.0 AIR PRESSURE REGULATOR.....</i>	<i>2</i>
<i>3.0 SOLENOID MANIFOLD - CLEANING.....</i>	<i>3</i>
<i>4.0 DRIVE CYLINDER SQE CLEANING.....</i>	<i>4</i>
<i>5.0 TSM-20 PARTS LIST.....</i>	<i>5</i>
<i>Appendix A - Wiring Diagram.....</i>	<i>6</i>
<i>Appendix B - Carriage Switch Diagram .....</i>	<i>7</i>
<i>Appendix C - Solenoid Pneumatic Diagram.....</i>	<i>8</i>



**CAUTION: ALWAYS DISCONNECT POWER AND AIR BEFORE ATTEMPTING ANY MAINTENANCE OR TESTING ON YOUR CASTLE MACHINE!**

## 1.0 SAFETY SWITCH CHECK

The safety switch on the TSM-20 is a micro switch located on the outside of the control box (Fig 1). When the safety buttons at the rear of the worktop are depressed by the stock, they actuate a blade inside the machine that presses against the button of the micro switch. Combined with the micro switch in the foot pedal these two micro switches are responsible for initiating the cycle on the TSM-20. If the switch has failed then the machine will not begin the cycle, essentially your clamp will not go down and the routers will not move, though they will turn on.



FIG 1

### 1.1 To Test:

1. Disconnect air and power.
2. Test for continuity at the switch by connecting the ohmmeter leads to wired side of the micro switch. You will need to remove the orange cover plate to do this.
3. Press in the button on the micro switch. If the switch is working you should register continuity after you press in the button.
4. If no continuity is registered then the switch needs to be replaced.



**CAUTION: ALWAYS DISCONNECT POWER AND AIR BEFORE ATTEMPTING ANY MAINTENANCE OR TESTING ON YOUR CASTLE MACHINE!**

## 2.0 INTERNAL AIR PRESSURE REGULATOR

The internal air pressure determines the drill feed rate and the overall speed of the machine. The factory setting is 75 PSI. It is important for the machine function to have at 75 PSI to the machine.

Locate the regulator in the control box (Fig 2). Unlock the yellow lock ring by pulling it slightly toward the black knob. Turn the knob to the right (clockwise) to increase pressure. Turn the knob to the left (counter-clockwise) to decrease pressure. Push the lock ring back in when done.

**To completely reset the pressure, turn the knob all the way counter-clockwise and then turn it 5-6 full turns clockwise. This should bring your pressure to approximately 75 PSI.**

**NOTE: The speed of the cycle stroke is directly proportional to the pressure to the machine. Cycling too slow may cause drill bits to heat up in the wood and may cause separation. Cycling your machine too fast may cause undue pressure to the drill bits and may cause breakage and/or over-sized holes.**

PRESSURE  
REGULATOR

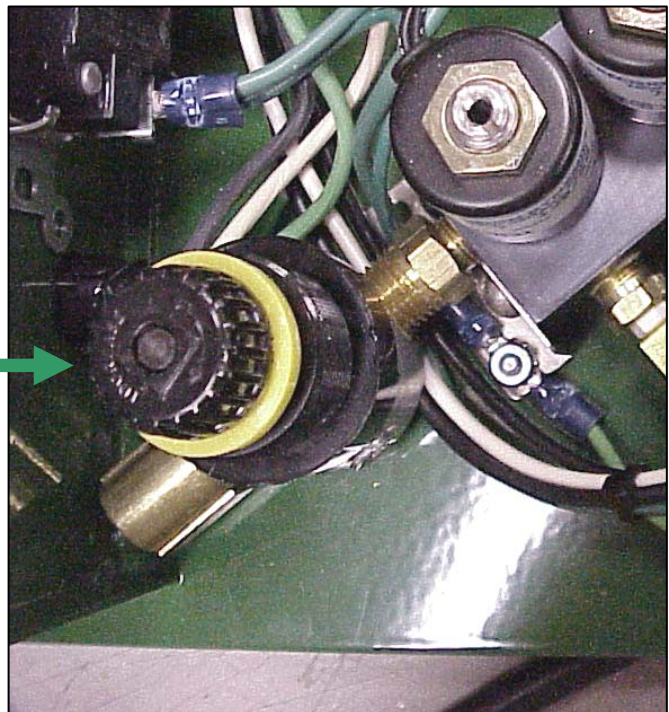

FIG 2



**CAUTION: ALWAYS DISCONNECT POWER AND AIR BEFORE ATTEMPTING ANY MAINTENANCE OR TESTING ON YOUR CASTLE MACHINE!**

### 3.0 SOLENOID MANIFOLD CLEANING

Begin by removing the control box from the machine. This can be done by removing the four screws on the outside of the case and sliding the box out. Once out, remove the plate from the front of the control box.

The coil located closest to the regulator in the upper left side of the control box (Fig 3) operates the Clamp. The middle coil actuates the Drill cycle and the coil furthest from the regulator actuates the Router.

#### TOOLS:

1. Pliers
2. Cloth or foam wrap to cushion the pliers to prevent damage to the coil when removing.
3. Rubbing alcohol
4. Clean rag
5. Compressed air

#### SOLUTION STEPS:

1. Use the pliers to remove the nut from the top of the coil. GENTLY remove the coil housing.
2. Cushion the pliers and CAREFULLY remove the stem. Once you have removed the stem verify that the plunger actuates on the bottom.
3. Blow out the manifold with air and wipe away any debris.
4. Wipe down the stem with rubbing alcohol.
5. Make sure that all parts of the manifold and the stem are clean.
6. CAREFULLY replace the stem using the cushioned pliers.
7. Replace the coil and nut.

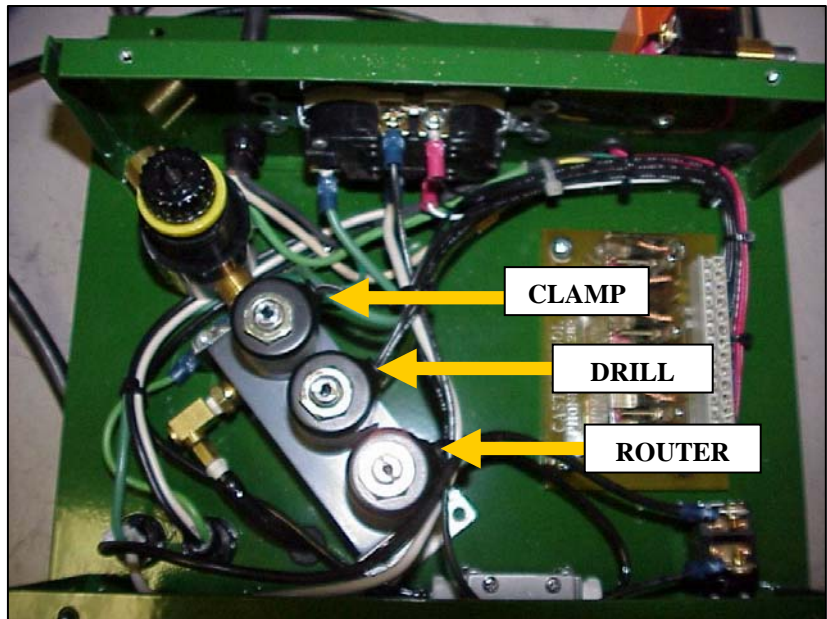

FIG 3



**CAUTION: ALWAYS DISCONNECT POWER AND AIR BEFORE ATTEMPTING ANY MAINTENANCE OR TESTING ON YOUR CASTLE MACHINE!**

## 4.0 DRIVE CYLINDER SQE CLEANING

The drill solenoid is an air switch that controls the flow of air to the drive cylinder. The drive cylinder, in turn provides the pressure to move the drill carriage through its cycle. If the air line becomes clogged the drive cylinder may not have enough pressure to cycle the drill completely.

### SOLUTION STEPS:

1. Open the back door
2. Inspect the hoses coming FROM THE DRIVE CYLINDER for holes and/or pinches.
3. Unplug the two DRIVE CYLINDER hoses from the solenoids. This is done by following the air lines back to their connection at the control panel. The hoses should remain attached to the air cylinder at the SQE's (Fig. 4)
4. Dry cycle the machine:
  - a. Unplug the router motors
  - b. Hold in the safety stock sensors below the clamp with two scraps of wood. **Be careful to leave room for the router to come up through the work surface unobstructed!**
  - c. Reach into the rear door opening and firmly grasp the yellow carriage.
  - d. Steadily pull and push the carriage fully back and forth to force air through the hoses. **BE SURE TO ALLOW THE AIR PRESSURE TO FULLY EXHAUSE OUT THE HOSES.**
5. Make sure air is coming out of the solenoids while dry cycling
6. The hoses attached to the cylinder should exhaust air as you dry cycle knocking loose any blockage out of the brass SQE's as well as cleaning any debris out of the air hoses.
7. Press the hoses firmly back into the push-in fittings.
8. Plug in the router motors.

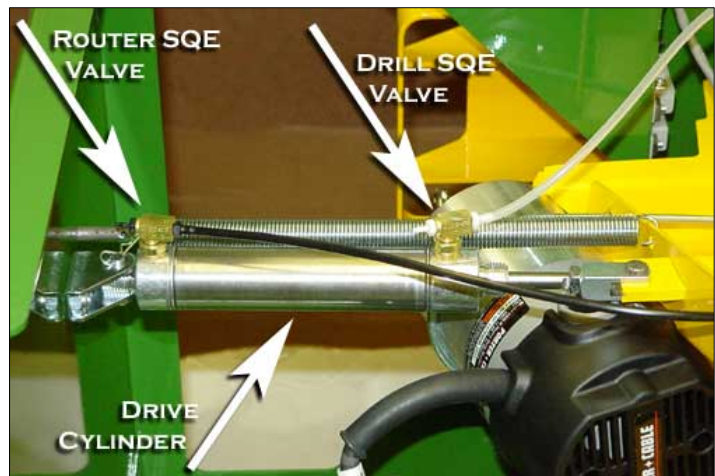

FIG 4

# TSM-20 PARTS LIST

Castle Part #	Part Description
<b>Drill &amp; Router Motors &amp; Accessories</b>	
E23102	Porter Cable 3102 Trimmer Motor (Drills hole) <b>DISCONTINUED</b>
E26902	Porter Cable 6902 Router Motor (Routs pocket; mount with F14232 bolt) (same router as TSM-21)
D50014	1/4" Collet Assembly (for E23102 motor)
	Note: Brass bushing no longer available; replaced by 1/4" shank on the bit
D50031	Collet Nut
<b>Microswitches</b>	
E60286	Snap-action Microswitch (Silver push button) (Drill Stop, Rout Stop, and Wood Sensor Switch)
	Note: Grainger Part No. 6X286 Manufacturer Part No. Z-15GQ-B7-K
E60284	Snap-action Microswitch (with Lever) (Used in older versions)
	Note: Grainger Part No. 6X284 Manufacturer Part No. Z-15GW-B7-K
E07033	Microswitch (Small, white with Lever) (Used in oldest versions)
	Note: Grainger Part No. 6A884 Manufacturer Part No. TMCG40
E07041	Snap-action MicroSwitch (Small push button) (Foot Switch for TSM 20, 21 & 35)
	Note: Grainger Part No. 6X283
<b>Control Board</b>	
E20120	EL-06 3-Relay Control Board (EL-06 is compatible with all models)
	Note: Revision EL-05A and EL05B no longer available - Refer to Electrical Wiring diagram
	<b>DISCONTINUED</b>
<b>14 Pin Terminal Strip</b>	
E20014	14 Pin Terminal Strip (for Relay Control Board)
<b>Regulator</b>	
P53000	Monnier Regulator
	Note: Must be calibrated to 85psi by shipping dept. prior to shipping
<b>Drive Cylinder</b>	
C21004	Drive Cylinder
	Note: Same as TSM-21 drive cylinder
<b>Manifold-Fabco</b>	
P13013	Fabco Valve Assembly (3 valves included with Manifold)
<b>Solenoid Coil - Fabco</b>	
E20126	Solenoid Valve (Clamp, Rout and Drill valves)
<b>Flow Control</b>	
P00117	SMC Flow Control
	Note: Same as Feed Speed valve used on TSM-21 & 35
<b>On/Off Toggle Switch</b>	
E75762	On/Off Switch (silver metal)
<b>SQE (Super Quick Exhaust)</b>	
P10320	SQE 10-32 Clippard
	Note: small, brass;
<b>SQE (Super Quick Exhaust)</b>	
P10001	Humphrey SQE-1
	Note: larger than P10320, octagonal, nickel
<b>SQE White Nylon Barb</b>	
P10325	10-32 x 5/32 ID Black Barb (for P10320 when used as Clamp Exhaust)
P31032	10-32 x 10-32 White Nylon Coupling (for P10320 when used as Clamp Exhaust)
<b>18 AWG Hook Up Wire</b>	
E18061	Brown



# Castle TSM-20

## Appendix B

## Wiring Diagram

20.80

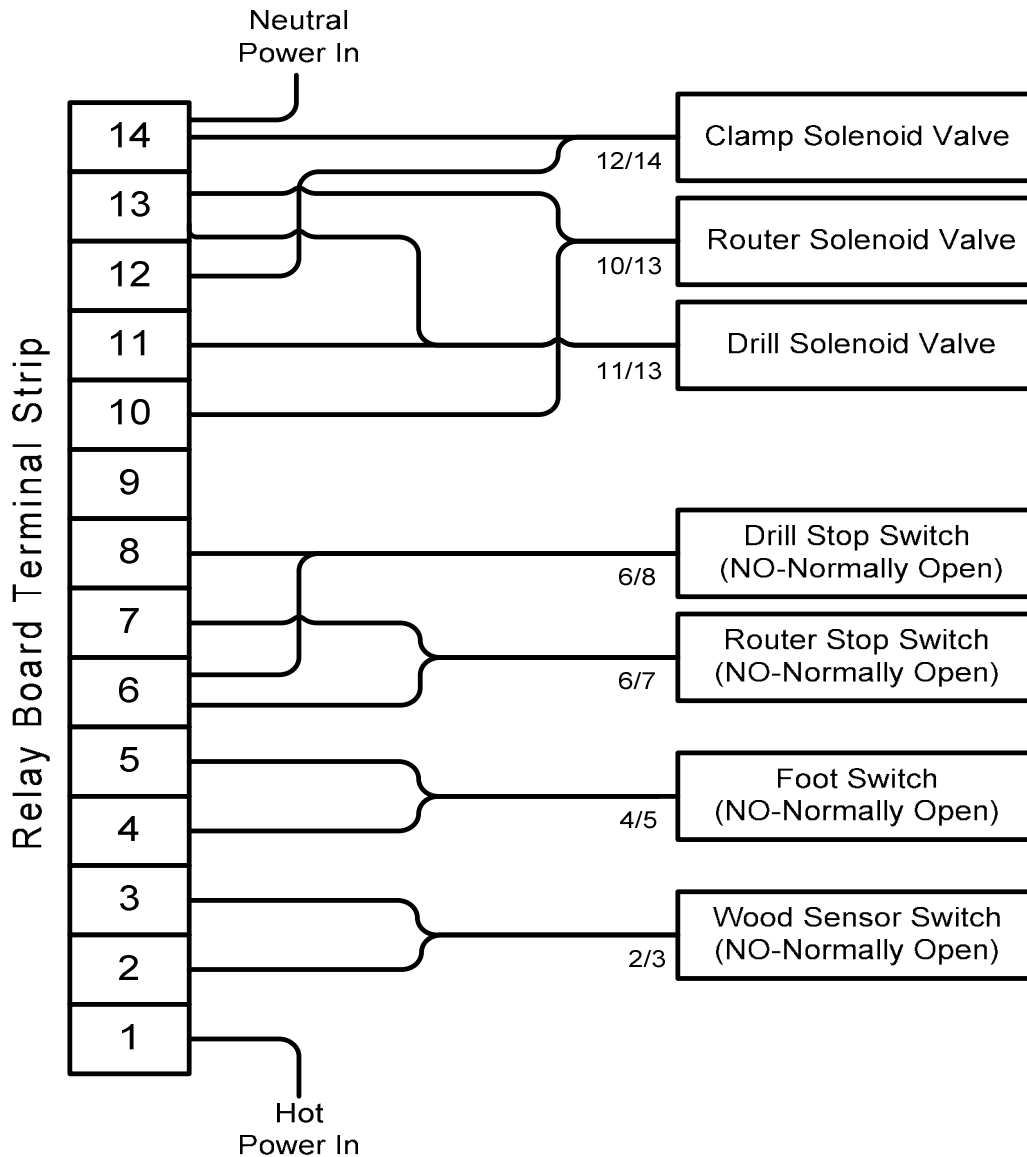





# Castle TSM-20

## Appendix B Carriage Switch Diagram 20.82

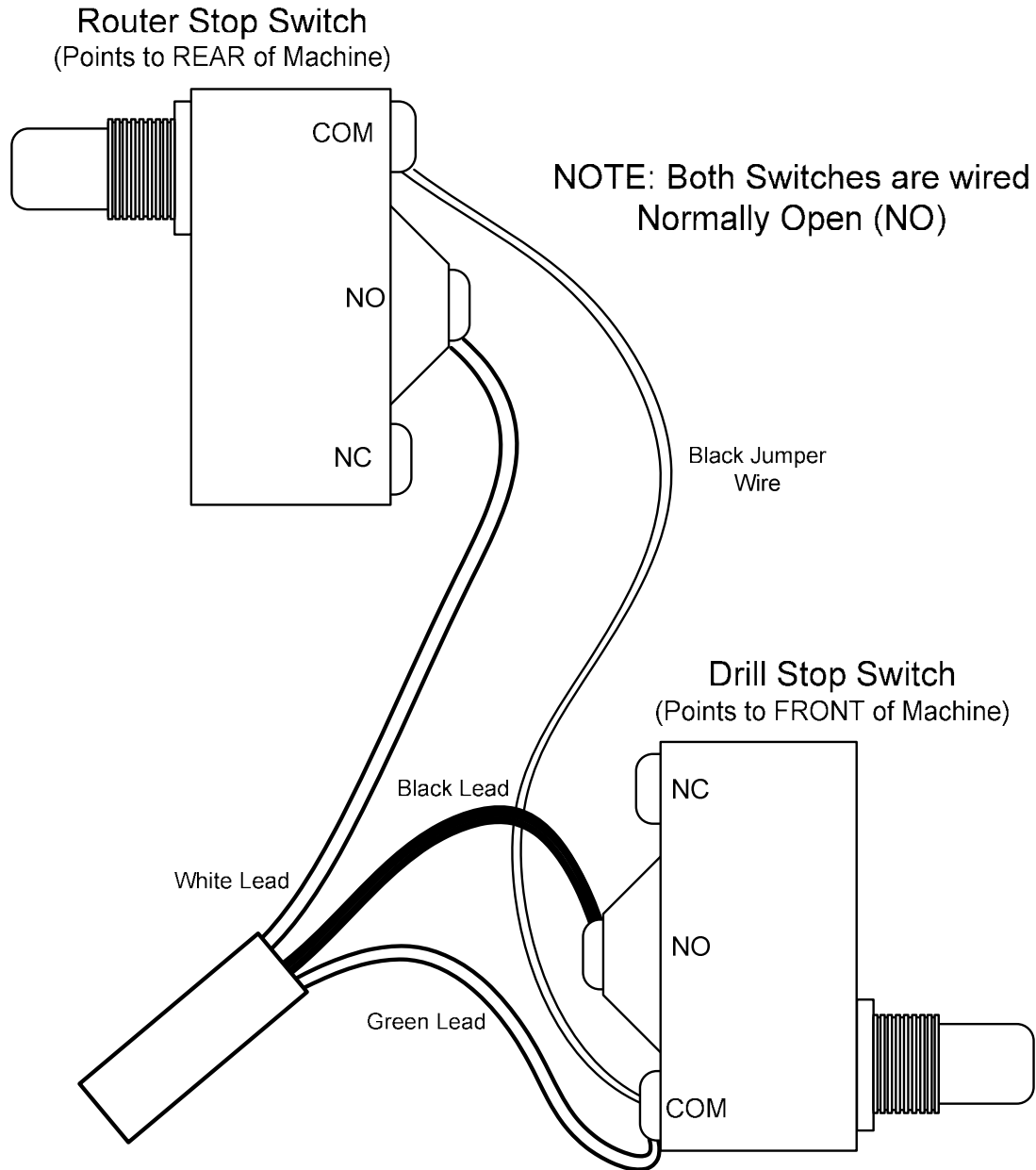

Castle, Inc. 1364 N. McDowell Blvd. PO Box 750236. Petaluma CA 94975  
(800) 282-8338 Fax (707)765-0953 [www.castleusa.com](http://www.castleusa.com)



# Castle TSM-20

## Appendix C Solenoid Pneumatic Diagram 20.81

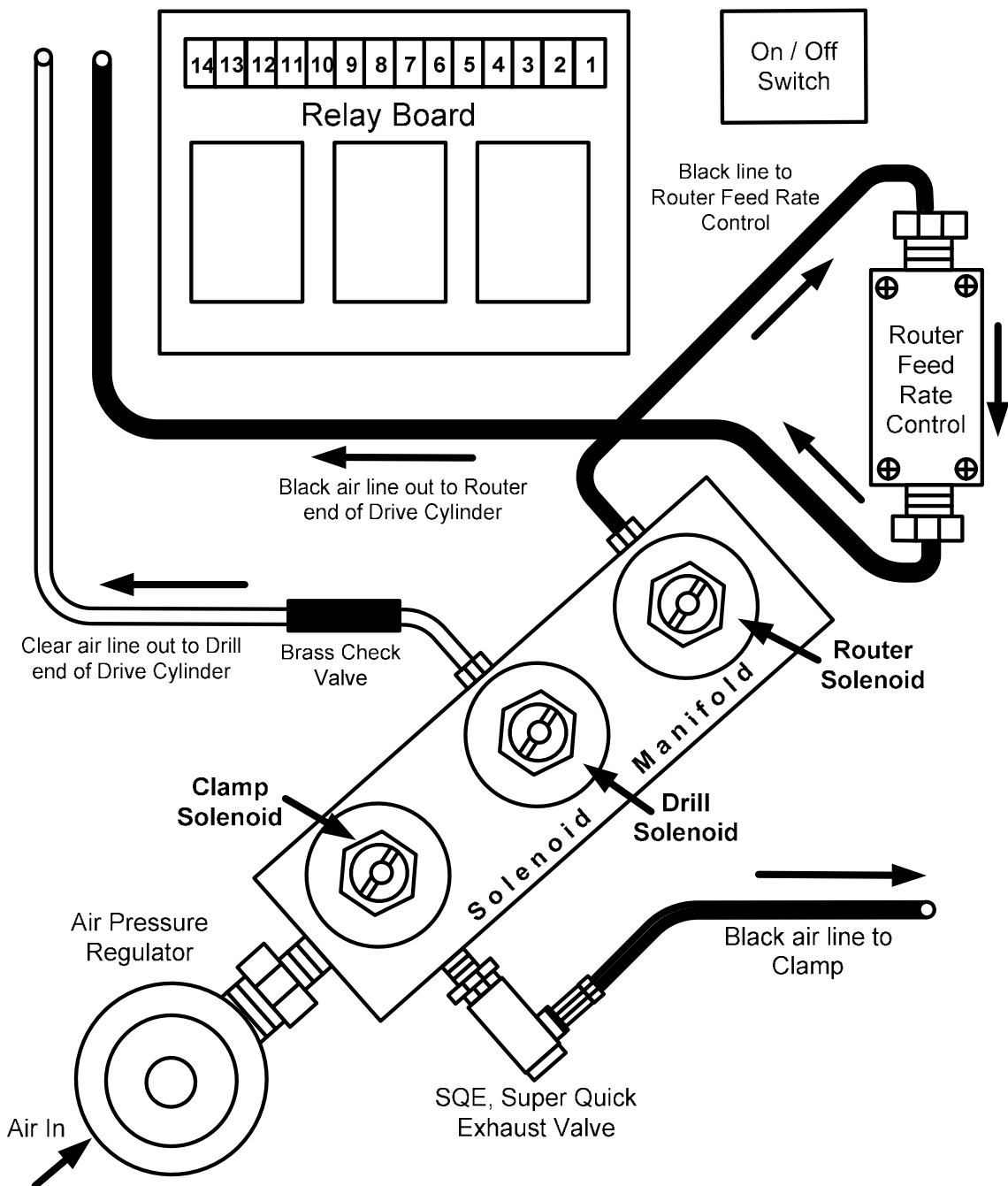

Castle, Inc. 1364 N. McDowell Blvd. PO Box 750236. Petaluma CA 94975  
(800) 282-8338 Fax (707) 765-0953 [www.castleusa.com](http://www.castleusa.com)