

VIDAR Systems Corporation



***Advantage*PRO** **Series**

User Guide

for Use With Windows XP & Windows 7

Advantage Series (Serial Numbers 340000 to 369999)

DiagnosticPRO® Advantage

DosimetryPRO® Advantage

CAD PRO® Advantage

© Copyright 2010 by VIDAR® Systems Corporation. All rights reserved.

Terms denoted by the trademark symbol (™ or ®) used in this publication are trademarks or service marks registered in the United States or other countries.

NOTE

The digitizers do not include application specific software (Picture Archiving and Communications [PAC] system, Teleradiology, Oncology Systems, or Computer Aided Detection [CAD] software). The manufacturer of the application software will determine specific indications for use. These third-party software packages or complete systems are approved separately from a regulatory perspective.

The digitizers are marketed as a component to application software development companies, who will incorporate the digitizer into their respective PACS or Teleradiology, CAD system(s). The software developer is ultimately responsible for detailing the Contraindications for the PACS System (or Teleradiology software package) or Oncology Systems as a whole, including the digitizer.



365 Herndon Parkway
Herndon, VA 20170 U.S.A.

Phone: 1-703-471-7070
Fax: 1-703-471-7665
Internet: www.filmdigitizer.com

Sales: 1-800-471-SCAN or 1-800-471-7226
Email: sales@vidar.com

Technical Support:
Phone: 1-800-471-SCAN or 1-703-471-7070
E-mail: medtech@vidar.com

Authorized representative
in Europe

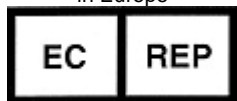

Emergo Europe
Molenstraat15
2513 BH, The Hague
The Netherlands

Phone: +31 (0) 70.345.8570
Fax: +31 (0) 70.346.7299
E-mail: service@emergogroup.com

Caution: No operator-serviceable parts inside. Refer servicing to qualified personnel.
Achtung: Gehäuse nicht öffnen. Wartung und Reparatur nur durch Elektrofachkräfte.
Attention: Aucune pièce ne peut être remplacée par l'utilisateur. Toute opération de maintenance doit être effectuée par une personne qualifiée.
Atencion: Acceso interno solo autorizado a personal técnico cualificado.
Attenzione: Non aprire. Rivolgersi a personale qualificato.

Radio Frequency Emissions

This equipment has been tested and found to comply with the limits for a Class A digital device, pursuant to Part 15 of the FCC Rules. These limits are designed to provide reasonable protection against harmful interference when the equipment is operated in a commercial environment. This equipment generates, uses, and can radiate radio frequency energy and, if not installed and used in accordance with the instruction manual, may cause harmful interference to radio communications. Operation of this equipment in a residential area can cause harmful interference, in which case the user will be required to correct the interference at his or her own expense.

Product compliance testing was conducted using VIDAR shielded cables. Modifications to the digitizer or the VIDAR shielded cables or the use of cables other than those available from VIDAR could void the user's authority to operate the equipment.

Acceptable shipping conditions

- Temperature: -18° to $+60^{\circ}\text{C}$ (0° to $+140^{\circ}\text{F}$)
- Relative humidity: 20% to 85%, non-condensing
- Atmospheric pressure: 500 to 1060hPa (+18,000 to -1,200ft)

Operating conditions

- Temperature: 10°C to 30°C (60°F to 85°F)
- Relative humidity: 20% to 85%, non-condensing
- Atmospheric pressure: 696 to 1013hPa (10,000 to 0 ft)

Electrical supply

- Voltage: 100 to 240 VAC
- Current: 0.75 to 1.5 A
- Frequency: 47 to 63 Hz

Safety and compliance information



MEDICAL EQUIPMENT WITH RESPECT TO ELECTRIC SHOCK, FIRE AND MECHANICAL HAZARDS ONLY IN ACCORDANCE WITH UL60601-1, IEC60601-1 AND CAN/CSA C22.2 No. 601.1



DiagnosticPRO® Advantage, DosimetryPRO® Advantage and CADPRO® Advantage carry the CE mark, issued by BSI.

This product's function and intended use is making digital copies of medical x-ray films. This product is intended to be turned on and left on. Operation is continuous. To maintain Medical Equipment Certification, the digitizer must be connected to a host computer that has been configured in accordance with IEC 60601-1-1.

This product is in the Ordinary Equipment Class. It provides no protection against the ingress of water.

This product is not suitable for use in the presence of flammable anesthetic mixtures with air or with oxygen or with nitrous oxide.

Class I Medical Device; No Applied Parts. This product provides Class I medical device protection against electrical shock.

Power cords used with this device in North America must be rated by Underwriters Laboratories for hospital use. Power cords used with this device in Europe must meet the requirements of IEC 227 Designation 53 or IEC 245 Designation 53.

Correct and safe operation of the digitizer requires familiarity with information that is not marked on the product. The following symbol indicates the operator should consult the manual for additional information.



This Class 1 LED device is safe under reasonably foreseeable conditions of operation.

The LED illumination system consists of 16 Class 1 LEDs, a mirror system to spread the light, and a diffuser to distribute the light approximately uniformly across an area of 2.4 sq in (15.5 sq cm). Light from the LED illuminator may be indirectly observed in the digitizer's film entry and exit areas.

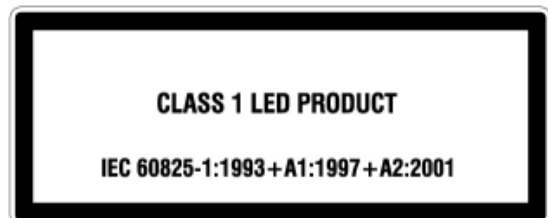

Contents

Operating the DiagnosticPRO[®] Advantage and DosimetryPRO[®] Advantage (Red)	6
About Digitizers and Film Sizes.....	6
DiagnosticPRO [®] Advantage specifications	6
DosimetryPRO [®] Advantage specifications.....	7
About Films.....	8
Basic Operating Instructions.....	9
Digitizing a Single Film	10
Digitizing Multiple Films.....	12
Operating the CAD PRO[®] Advantage	14
Film Sizes and Scanning Specifications.....	14
About Films.....	15
Operating Instructions	16
Preventive Maintenance	18
Cleaning the Auto-Feed Roller	18
Cleaning the Auto-Feed Roller and Suction Cups	19
Cleaning the Diffuser	21
Replacing the Lamp Cartridge.....	25
Troubleshooting	26
Reading the LEDs	26
Top LED: feeder status	27
Center LED: Digitizer Status.....	27
Bottom LED: Power Status	28
In Case of Difficulty.....	28
Weights and Dimensions	31
Shipping weight and dimensions	31
Digitizer weight and dimensions: DiagnosticPRO [®] Advantage and DosimetryPRO [®] Advantage.....	31
Digitizer weight and dimensions: CAD PRO [®] Advantage.....	31
Packing the Film Digitizer for Shipment	32
1. Turn Off the Digitizer	32
2. Disconnect the Power Cord and USB Cable.....	32
3. Remove the Exit Tray from the Digitizer Base	33
4. Remove the Feeder from the Digitizer Base	34
5. Remove the Digitizer Base from the Stand	35
6. Prepare the Feeder	36
7. Wrap Certain Items.....	37
8. Pack the Accessory Box.....	38
9. Pack the Shipping Carton.....	41
Appendix: Electromagnetic Guidance	42
Appendix: Symbols	46

Operating

the DiagnosticPRO[®] Advantage and DosimetryPRO[®] Advantage (Red)

About Digitizers and Film Sizes

This section describes important differences between the DiagnosticPRO[®] Advantage and DosimetryPRO[®] Advantage.

DiagnosticPRO[®] Advantage specifications

Nominal resolution	Pixels (14"x17" film)	Spot size (µm)	DPI	Line pairs per mm
1k x 1.25k	1008 x 1124	340	75	1
2k x 2.5k*	2002 x 2431	170	150	3
4k x 5k	3990 x 4845	85	300	6

Mammography film: 18cm x 24cm

4k x 5k	4104 x 5472	44	570	11
---------	-------------	----	-----	----

*ACR Standard for Teleradiology Guidelines [Revision 35 (1998)] recommends 2.5 lines pairs/mm minimum

Scan modes 32-bit mapped to 12-bit and 8-bit grayscale outputs

Film sizes
(manual feed) Width: 6" to 14" (20.3cm to 35.6cm)
Length: 8" to 51"† (20.3cm to 129.5cm)
Thickness: 0.006" to 0.010" (0.15mm to 0.51mm)
†Longer films require user support during feeding, and a scanning application that handles long films

Auto film feeder Standard 25-film capacity (mixed sizes, no presorting)
"Light box loading": head-up, normal reading, left justified
Width: 7" to 14" (20.3cm x 35.6cm)
Length: 8" to 17" (20.3cm x 43.2cm)
Thickness: 0.006" to 0.010" (0.15mm to 0.51mm)

DosimetryPRO[®] Advantage specifications

Nominal resolution	Pixels (14"x17" film)	Spot size (µm)	DPI	Line pairs per mm
1k x 1.25k	997 x 1211	356	71.25	1.4
2k x 2.5k*	1995 x 2422	178	142.5	2.8
4k x 5k	3990 x 4845	89	285	5.6

*ACR Standard for Teleradiology [Revision 35 (1998)] recommends 2.5 lines pairs/mm minimum

Scan modes 32-bit mapped to 12-bit and 8-bit grayscale outputs

Film sizes (manual feed) Width: 6" to 14" (20.3cm to 35.6cm)
Length: 8" to 51"† (20.3cm to 129.5cm)
Thickness: 0.005" to 0.009" (0.127mm to 0.228mm)
†Longer films require user support during feeding, and a scanning application that handles long films

Auto film feeder Standard 25-film capacity (mixed sizes, no presorting)
"Light box loading": head-up, normal reading, left justified
Width: 7" to 14" (20.3cm x 35.6cm)
Length: 8" to 17" (20.3cm x 43.2cm)
Thickness: 0.005" to 0.009" (0.127mm to 0.228mm)

Note: ISP 14" x 17" is cut true to size and is therefore slightly larger than standard 14" x 17" film (which is actually measured in metric and therefore slightly smaller). This results in a very tight fit between the digitizer's film guides. In most cases, the films can be manually loaded and may need to be assisted through the device. In the worst case, the film may need to be slightly trimmed before feeding. Films will not be properly fed using the automated film feeder.

About Films

The film digitizer handles standard radiograph films up to 14" x 17" (35.5cm x 43cm).

You can feed multiple films (up to 25), and you can mix film sizes ranging from 8" x 10" (20.3cm x 24.5cm) to 14" x 17" (35.5cm x 43cm) in one stack—as long as you follow the rules below.

IMPORTANT: Remove stickers, tape, staples, paper clips, etc. from films before scanning. These may cause serious film feeding problems and may damage the digitizer's internal mechanisms. **Failure to remove extraneous items from films will void your warranty.**

Load films just as you would view them on a light box, with these qualifications:

- Films less than 8" wide will not be detected by the digitizer's film sensor, and therefore will not be staged or digitized.

CAUTION: Paper, paper films and films smaller than 8" x 8" can fall into the internal optics box and cause damage not covered by your warranty.

- Do not load films more than 17" (43.2cm) long in the auto feeder. (See "Digitizing a single film," later in this chapter, when loading films longer than 17".)

Basic Operating Instructions

1. Turn on the film digitizer and wait for all three LEDs to turn green.

Note: Always turn on the film digitizer before turning on the computer. This enables the computer to recognize the digitizer.

Note: Several minutes are required for the digitizer to carry out its internal diagnostics and establish communications with the scanning application. These activities must be completed before you can load film into the digitizer.

2. Turn on the computer.
3. Launch the scanning application.

IMPORTANT: Remove stickers, tape, staples, paper clips, etc. from films before scanning. These may cause serious film feeding problems. Failure to remove extraneous items from films will void your warranty.

4. If you will be digitizing films 17" (43.2cm) or longer, raise the film support bar.

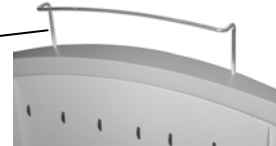

5. Load the film.

How you load the film depends on whether you are digitizing one film or multiple films. See the next pages for details.

CAUTION: X-ray images displayed on a computer monitor are representative only. A variety of factors influence image density and size—including monitor luminance and calibration, window and level settings, zoom level, and dimensional and grayscale inaccuracies resulting from build-up of tolerances in the digitizer, display board and computer. For this reason, special precautions must be exercised (e.g., calibrating the software ruler and computer monitor) when taking measurements from digitized images. Please refer to the user's manual for your digitizing software for more information.

Digitizing a Single Film

Options for digitizing single films

There are two ways to scan a single film:

- By manually inserting the film behind the blue bar (as described in this section), or
- By treating the single film as a batch of one (if the scanning application supports this approach); for instructions, see “Scanning multiple films” (next section in this manual).

The digitizer cannot feed films smaller than 8" wide x 8" long (20.3cm wide x 20.3cm long). Do not scan paper.

1. Hold the film in front of you as you would view it on a light box.
2. Align the left edge of the film with the film guide on the left of the feeder.
3. Place the film into the slot **BEHIND the blue bar**.

The blue bar has a lip and a groove on the top edge of the digitizer where the feeder is attached. Place a single film directly behind the blue bar.



When the digitizer senses the film, it automatically stages the film in preparation for digitizing. The film will first move down, then up. This is normal operation.

CAUTION: If the film is not staged properly, do not manually pull the film out of the digitizer. Instead, use the scanning application’s EJECT command to remove the film.

Note: When a film has been staged, it is in the digitizer’s light path. The ADC (Automatic Digitizer Calibration) feature requires that the light path be clear of the film for proper background calibration of the digitizer. The digitizer will automatically adjust the film’s position to properly proceed with ADC. Depending on the location of the film’s leading or trailing edge, and the length of time the film has been blocking the light path, the film will be: a) pushed up, or b) pushed down.

4. Using your scanning software, execute the **Scan** command.

Note: Proper orientation of the film during loading depends on the scanning application program you are using. Some scanning programs rotate images 180° for display. If images appear upside down, you may be able to set the default orientation in the scanning application. If this option isn't available, then insert films into the digitizer upside down, as shown here.

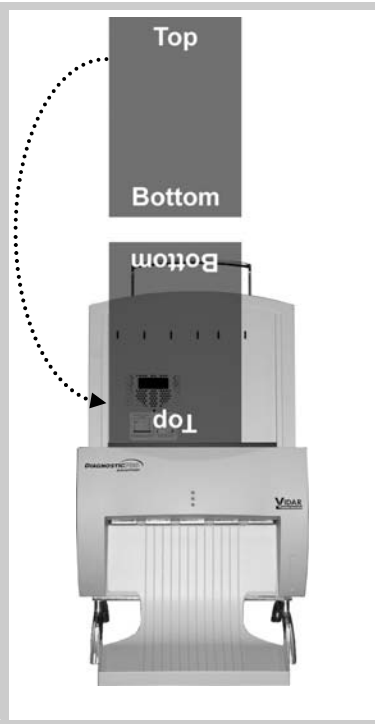

Digitizing Multiple Films

CAUTION: Do not load more than 25 films at one time.

1. Hold the film stack in front of you as you would view it on a light box.

Films at the back of the stack are digitized first.

Note: The digitizer cannot feed films smaller than 8" wide x 8" long (20.3cm wide x 20.3cm long). When loading small films, the vertical dimension must be at least 8" (20.3cm). Do not scan paper.



2. Align the left edge of the film stack with the film guide on the left edge of the feeder.
3. Place the film stack **IN the groove in the blue bar**.

The blue bar has a lip and a groove on the top edge of the digitizer where the feeder is attached. Place a single film directly behind the blue bar.

Note: If you are digitizing a single film, place the film **BEHIND the blue bar**.

Note: When a film has been staged, it is in the digitizer's light path. The ADC (Automatic Digitizer Calibration) feature requires that the light path be clear of the film for proper background calibration of the digitizer. The digitizer will automatically adjust the film's position to properly proceed with ADC. Depending on the location of the film's leading or trailing edge, and the length of time the film has been blocking the light path, the film will be: a) pushed up, or b) pushed down.

4. Using your scanning software, execute the **Scan** command.

Note: During extended batch scans (more than 5 films), the digitizer may pause periodically to recalibrate. This is normal operation.

Note: Proper orientation of the film during loading depends on the scanning application program you are using. Some scanning programs rotate images 180° for display. If images appear upside down, you may be able to set the default orientation in the scanning application. If this option isn't available, then insert films into the digitizer upside down, as shown here.

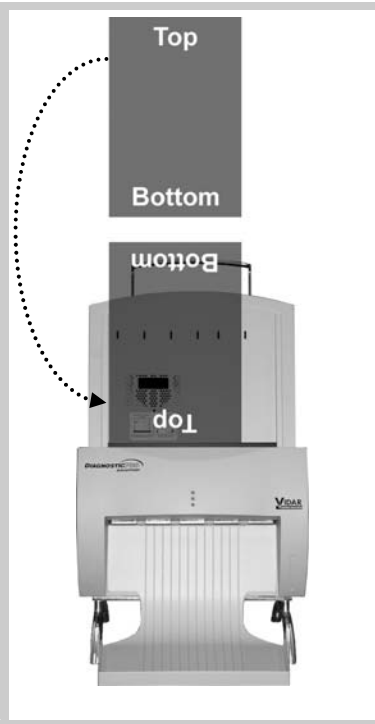

Film Sizes and Scanning Specifications

**18cm long x 24cm wide mammography film
(Landscape orientation)**

Pixels	Spot size (μm)	DPI	Line pairs per mm
4032 x 5376	44	570	11

**30cm long x 24cm wide mammography film
(Portrait orientation)**

Pixels	Spot size (μm)	DPI	Line pairs per mm
6720 x 5376	44	570	11

Scan modes	32-bit mapped to 16-bit and 12-bit grayscale outputs
Film sizes	Fixed width: 24cm Length: 18cm or 30cm Thickness: 0.006" to 0.010" (0.15mm to 0.51mm)
Auto film feeder	50 capacity (mixed sizes) "Light box loading": head-up, normal reading

About Films

The film digitizer handles standard 18cm x 24cm and 24cm x 30cm mammography films.

You can feed multiple films (up to 50), and you can mix film sizes.

IMPORTANT: Remove stickers, tape, staples, paper clips, etc. from films before scanning. These may cause serious film feeding problems and may damage the digitizer's internal mechanisms. **Failure to remove extraneous items from films will void your warranty.**

To prepare films for digitizing:

- Stack each group of films according to the sequence specified by the CAD system manufacturer. A typical sequence is shown below.
- Place a separator in each group. Use separators approved by the CAD system manufacturer.

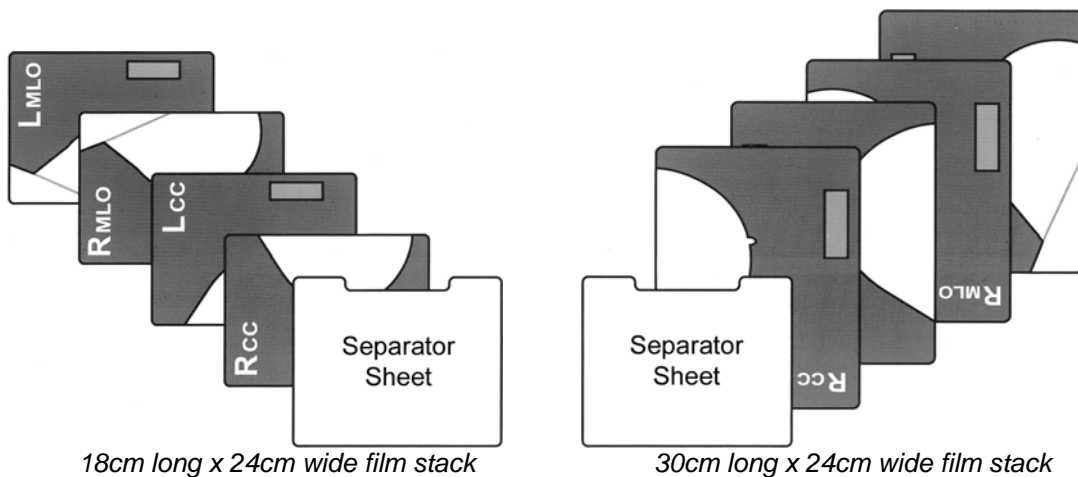

Operating Instructions

1. Turn on the film digitizer and wait for all three LEDs to turn green.

Note: Always turn on the film digitizer before turning on the computer. This enables the computer to recognize the digitizer.

Note: Several minutes are required for the digitizer to carry out its internal diagnostics and establish communications with the scanning application. These activities must be completed before you can load film into the digitizer.

2. Turn on the computer.
3. Launch the scanning application.

IMPORTANT: Remove stickers, tape, staples, paper clips, etc. from films before scanning. These may cause serious film feeding problems. **Failure to remove extraneous items from films will void your warranty.**

CAUTION: X-ray images displayed on a computer monitor are representative only. A variety of factors influence image density and size—including monitor luminance and calibration, window and level settings, zoom level, and dimensional and grayscale inaccuracies resulting from build-up of tolerances in the digitizer, display board and computer. For this reason, special precautions must be exercised (e.g., calibrating the software ruler and computer monitor) when taking measurements from digitized images. Please refer to the user's manual for your digitizing software for more information.

4. Hold the stack in front of you as you would view it on a light box.
5. Slide the stack into the feeder, between the guides. **Do not overfill the feeder:**
 - The 50 sheet feeder can hold up to 50 sheets at a time.

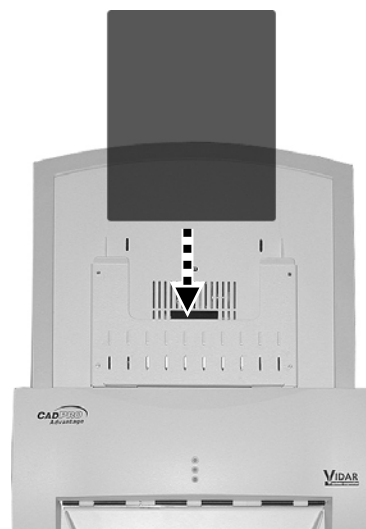

6. Using your scanning software, execute the **Scan** command.
7. Monitor the exit tray, and remove films periodically to prevent it from overflowing. The exit tray can hold up to 100 films. If it becomes overfilled, films may be damaged or jam in the digitizer.

Preventive Maintenance

Cleaning the Auto-Feed Roller

DiagnosticPRO® Advantage and DosimetryPRO® Advantage ONLY

After extensive use, dust or lint particles may build up on the Auto-Feed Roller. VIDAR recommends cleaning the roller at least twice per year.

Loop a piece of light adhesive tape (such as Scotch® Magic™ Tape) around your fingers with the adhesive side out, then gently pat the roller. Pat and turn the roller until its entire surface is clean.

Auto-Feed Roller

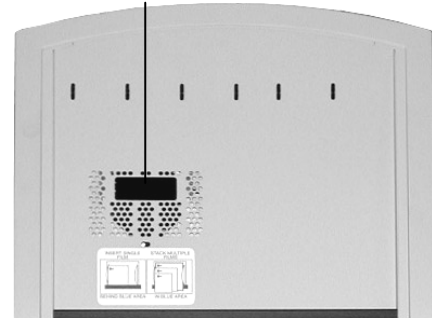

CAUTION:

- **Do not** use any type of cleaning solvent on the feed roller and idler wheels, as this could damage these components and cause improper operation.
- **Do not** use tape with a strong adhesive, such as packing tape or strapping tape.
- **Do not** use tape requiring the adhesive to be wetted, such as brown paper packing tape.

Cleaning the Auto-Feed Roller and Suction Cups

CAD PRO *Advantage* ONLY

After extensive use, dust or lint particles may build up on the Auto-Feed Roller and Suction Cups, and they must be cleaned to maintain reliable film feeding. VIDAR recommends cleaning the Auto-Feed Roller and Suction Cups at least twice per year. During cleaning, inspect the Suction Cups for wear.

1. Turn off the digitizer using the switch on the rear panel.
2. Remove the Film Guide from the feeder by loosening four screws. Loosen each screw a few turns, then move to the next screw. Repeat until the Film Guide is freed from the feeder.

Note: The screws are captive, but will come entirely out if unscrewed too far, and could then fall into the digitizer base. Be careful not to unscrew them from their captive locations. Removal of screws or other items from the inside of the digitizer is not covered under your warranty.

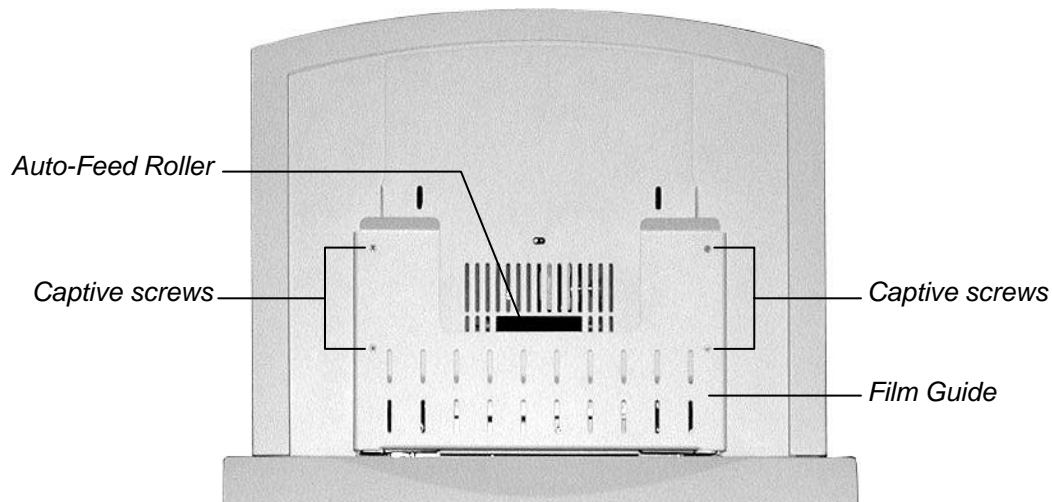

3. Remove residue from the Auto-Feed Roller: Loop a piece of light adhesive tape (such as Scotch® Magic™ Tape) around your fingers with the adhesive side out, then gently pat the roller. Pat and turn the roller until its entire surface is clean.
4. Gently pull the Suction Cups forward.
5. Examine the Suction Cups. If you see cracks or irregularities, you should replace the Suction Cups to prevent film feeding problems. Replacement Suction Cups (p/n 16272-00X) can be ordered from VIDAR.

6. Clean the Suction Cups using an isopropyl wipe (VIDAR part number 4100).

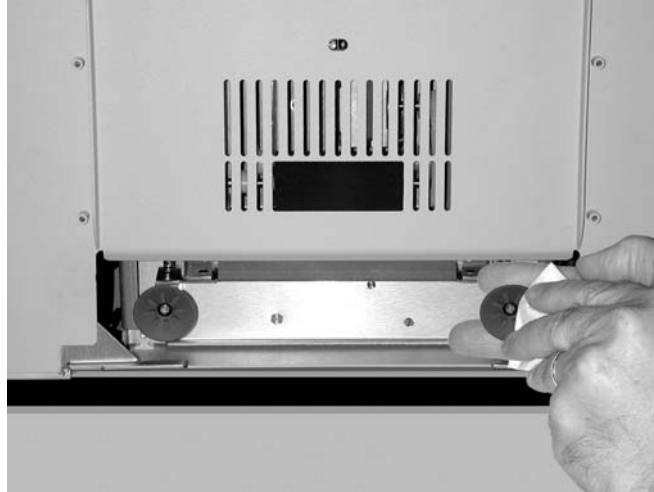

CAUTION:

- **Do not** use any type of cleaning solvent on the feed roller, as this could damage it and cause improper operation.
- **Do not** use tape with a strong adhesive, such as packing tape or strapping tape.
- **Do not** use tape requiring the adhesive to be wetted, such as brown paper packing tape.

7. Gently push the Suction Cups back in.
8. Secure the faceplate to the feeder with the four captive screws. **Tighten the screws a little at a time, in the order shown here:**

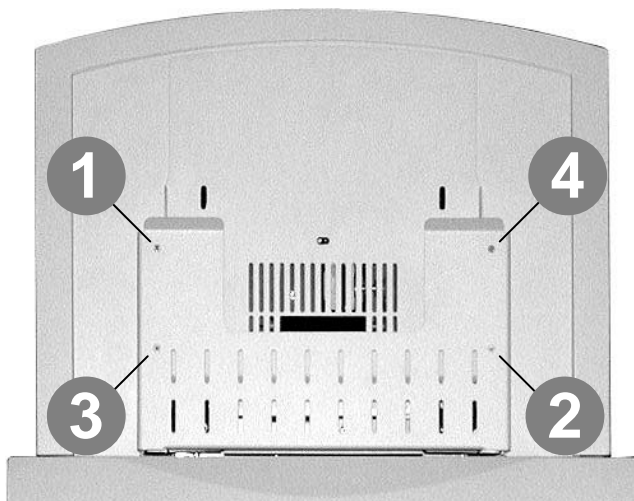

Cleaning the Diffuser

All Advantage Models

If you notice streaks (vertical artifacts) in images, you should clean the diffuser.

1. Turn off the digitizer. **Allow 10 to 15 minutes for the bulb cartridge to cool to a comfortable temperature before removing it.**
2. Open the door on the side of the digitizer base:
3. Remove the lamp Cartridge Clamp using a #2 Philips screwdriver. (May not be applicable in all models)

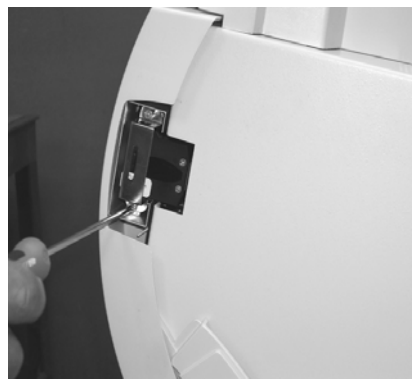

Note: The door has a “door open” sensor. When the door is open, all processes—including calibration and scanning—will stop.

4. Grasp the top and bottom of the lamp cartridge, then pull it out.



CAUTION: Do not touch the diffuser material with your fingers.

5. Place the lamp cartridge on a flat surface with the diffuser facing up.
6. Clean the diffuser using a lint-free wipe (VIDAR P/N: 15194 or P/N: 4247). **Wipe in one direction only. Don't wipe back and forth.**

CAUTION: The lamp cartridge assembly will resemble one of the images shown here.



IMPORTANT: DO NOT USE ALCOHOL or other SOLVENTS as they may degrade the diffuser and void your warranty.

7. Insert the lamp cartridge into the digitizer base:

- The diffuser must face the rear of the digitizer base.
- The end of the lamp cartridge with the white connector goes in first.
- Ensure the slots along the top and bottom of the cartridge align with the slides in the digitizer (see illustration at right).
- When the cartridge is nearly all the way in, push it firmly until you feel the connector snap into place.

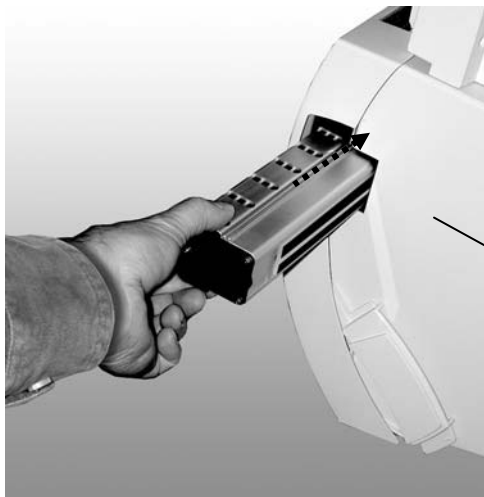
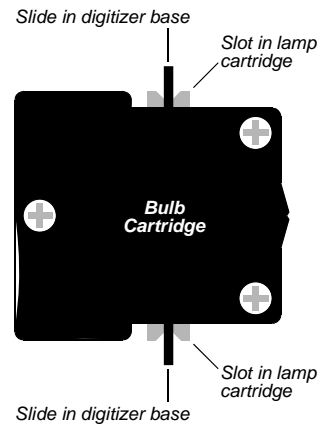

Slide cartridge in...



then push to seat connector

8. Re-install the lamp cartridge clamp assembly if removed earlier.



9. Close the door on the side of the digitizer base. Be sure the door closes fully.



10. Turn on the digitizer. The digitizer will recalibrate to the cleaned diffuser.

Replacing the Lamp Cartridge

All Advantage Models

WARNING: The lamp cartridge assembly is specific to each Advantage Model. Ensure you have the correct replacement lamp Cartridge before installing the new lamp.

Contact VIDAR Technical Support if you have any questions about installing or using your VIDAR film digitizer:

Phone: +1.800.471.SCAN (+1.800.471.7226)

+1.703.471.7070 outside the U.S.

E-mail: <mailto:medtech@vidar.com>

Follow the instructions in “Cleaning the Diffuser,” earlier in this chapter, but work with the new lamp cartridge in steps 5 through 10.

Preventive maintenance is not covered under warranty. (Only failures during the published warranty period are covered by warranty replacement. Failures must be confirmed by running VIDAR’s Digitizer Diagnostic Tool. The software generates a report showing light values indicative of lamp performance. You can request a copy of the Digitizer Diagnostic program from VIDAR Technical Support.)

Troubleshooting

Reading the LEDs

Three LEDs on the front of the digitizer provide operating information.

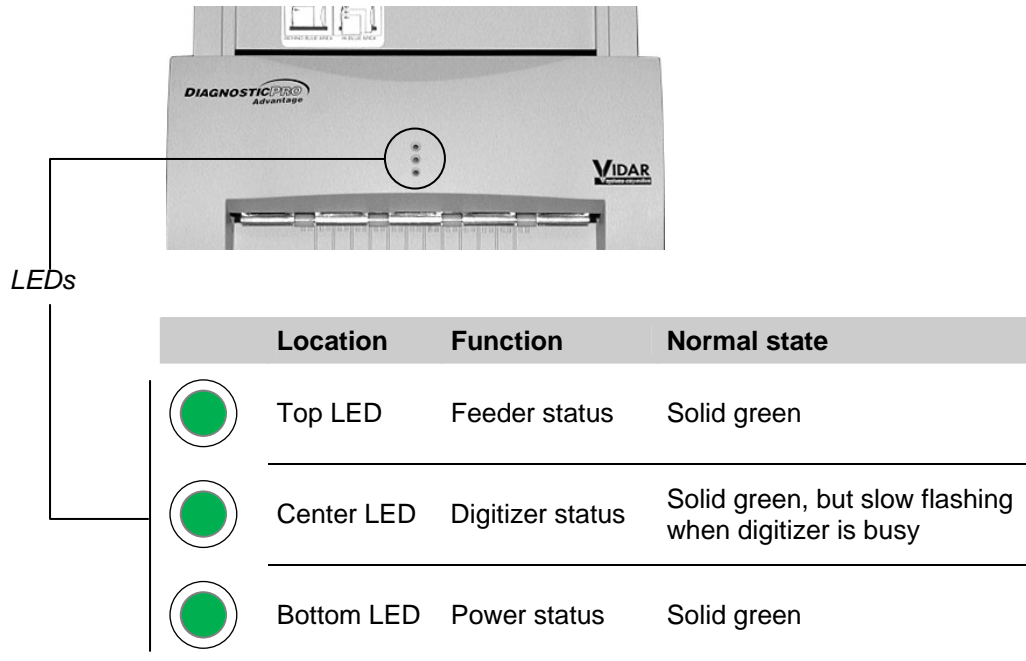

Tables on the next three pages explain all LED states.

Top LED: feeder status

LED state	Digitizer condition	Corrective action
Solid green	Ready	None. The feeder is ready to operate.
Off	ERROR: no feeder attached	<ol style="list-style-type: none">1. Turn off digitizer.2. Remove feeder.3. Inspect electrical connector and screws on bottom of feeder.
Fast flashing green	ERROR: unknown feeder attached	Check feeder: <ol style="list-style-type: none">1. Turn off digitizer.2. Remove feeder.3. Inspect electrical connector and screws on bottom of feeder.
Slow flashing green	BUSY: film is staging	None. This is normal operation.
Fast flashing green	ERROR: film staging problem	Eject film by clicking the eject button in the scanning application.

Center LED: Digitizer Status

LED state	Digitizer condition	Corrective action
Solid green	Ready	None. The digitizer is ready to accept commands from the scanning application.
Slow flashing green	BUSY: normalizing	None. This is normal operation. The LED will flash slowly during initial calibration after power is applied, and when the scanning application initiates a calibration.
Slow flashing green	BUSY: tracking (ADC)	None. This is normal operation. The LED will flash periodically when the digitizer is idle. Automatic Digitizer Calibration (ADC) is independent of the scanning application.
Slow flashing green	BUSY: staging film	None. This is normal operation. The LED will flash slowly while the digitizer is staging the film.
Slow flashing green	BUSY: Positioning film	None. This is normal operation. The LED will flash slowly while the scanning application is positioning the film.
Slow flashing green	BUSY: digitizing film	None. This is normal operation. The LED will flash slowly while a film is being digitized.
Slow flashing green	BUSY: ejecting film	None. This is normal operation. The LED will flash slowly while the scanning application is ejecting the film.
Off	ERROR	<ol style="list-style-type: none">1. Make certain power is supplied to the digitizer, and that the digitizer power switch is on.2. If problem persists, get qualified technical help (see "In case of difficulty," later in this chapter).

Bottom LED: Power Status

LED state	Digitizer condition	Corrective action
Solid green	Ready	None.
Fast flashing green	ERROR: DSP not communicating	Get qualified technical help (see “In case of difficulty,” later in this chapter).
Fast flashing green	ERROR: unknown ballast	Get qualified technical help (see “In case of difficulty,” later in this chapter).
Off	ERROR	<ol style="list-style-type: none"> 1. Make certain power is supplied to the digitizer, and that the digitizer power switch is on. 2. If problem persists, get qualified technical help (see “In case of difficulty,” later in this chapter).

In Case of Difficulty

How to use this section:

1. Look through the left columns to find a description of the problem you are having.
2. Follow the instructions (in order) in the “Corrective action” column. If the one corrective action doesn’t solve the problem, then carry out the next corrective action.
3. When the instruction is “Get qualified technical help,” then:
 - a. Contact your system integration specialist (the company or person that installed your VIDAR film digitizer).
 - b. If your system integration specialist isn’t available, then contact VIDAR Customer Support (medtech@VIDAR.com). Please record system information and digitizer serial number before calling, and have it available when calling.

Tip: Check www.filmdigitizer.com for current troubleshooting information, tools and software updates.

Symptom	Corrective action
Can’t turn digitizer on or off. Can’t find power switch.	The on/off switch is located on the rear of the digitizer body. Look at the digitizer from the rear to see the switch.
Streaks in image	Clean lamp diffuser (see “Cleaning the diffuser” in the “Cleaning and maintaining” chapter, earlier in this manual).
Bottom LED (power status) is off.	<p>Ensure wall outlet is providing AC power: obtain another electrical device known to be working, and plug it into that AC wall outlet.</p> <ul style="list-style-type: none"> ■ If other device doesn’t work, AC power is not available at that wall outlet. Get help from building services. ■ If other device does work, AC power is available from that outlet.

Symptom	Corrective action
Film starts and stops during scanning.	<ol style="list-style-type: none"> 1. Increase memory allocation for scanning software. (Especially if scanning at high resolutions, memory allocation must be sufficient to accept data stream from digitizer.) 2. If scanning to disk, ensure sufficient space is available on disk drive. 3. Ensure PC has enough memory available to support scanning application. Close applications not needed for image acquisition from digitizer. 4. If problem persists, get qualified technical help.
Digitizer stops scanning and PC locks up.	<ol style="list-style-type: none"> 1. Reset entire system: <ol style="list-style-type: none"> a. Turn digitizer off. b. Shut down PC. c. Turn digitizer on. d. After digitizer all three digitizer LEDs turn solid green, turn on PC. 2. Launch scanning software on PC, then try scanning again. If problem persists, get qualified technical help. 3. Check for correct device driver installation.
Digitizer was working properly, but after installing (or reinstalling) the scanning application there are Toolkit errors or the digitizer is not detected.	<ol style="list-style-type: none"> 1. If you installed a new scanning application, or if you reinstalled the existing application, the older Toolkit (<i>vscsi32.dll</i>) may have been installed. Run the VIDAR Drivers and Toolkit Installation CD (see appropriate section in the "Installing device drivers" chapter). 2. If problem persists, contact medtech@VIDAR.com.
Digitizer is not listed in Windows™ Control Panel under Scanners and Cameras.	<ol style="list-style-type: none"> 1. Update to STI drivers. See "Computers with Windows™ 2000 and Windows™ XP" in the "Installing device drivers" chapter. 2. Check all cables and connectors.
Digitizer is not detected.	<ol style="list-style-type: none"> 1. Check all cables and connectors. 2. Reset entire system: <ol style="list-style-type: none"> a. Turn digitizer off. b. Shut down PC. c. Turn digitizer on. d. After digitizer all three digitizer LEDs turn solid green, turn on PC.
Auto Feeder does not reliably feed films.	<ol style="list-style-type: none"> 1. Clean the lift roller on the Feeder. 2. CAD PRO only: Clean the Suction Cups inside the feeder (see "Cleaning the Auto-Feed Roller and Suction Cups" in the "Preventive maintenance" chapter). Be sure Suction Cups are not loose.

Symptom	Corrective action
Computer does not recognize the digitizer when it is connected through a USB cable.	<p>VIDAR firmware does not support USB 1.1. The digitizer may not be detected by the host computer if it is connected to a USB 1.1 port. The digitizer must be connected to a USB 2.0 port.</p> <ul style="list-style-type: none"> ■ Check the operating system to ensure the latest service pack is installed (Windows™ XP must have Service Pack 1 or higher; Windows™ 2000 must have Service Pack 4 or higher). Microsoft does not support USB 2.0 in older service packs. ■ If the computer does not have a USB 2.0 port, install a USB 2.0 adapter. Adaptec™ (www.adaptec.com) offers several USB 2.0 adapters. VIDAR has tested Adaptec's USB2Connect, p/n AUA-2000.
Windows XP does not recognize the USB-connected film digitizer when another USB scanner is connected to the system.	<p>Disconnect the other scanner from the system. Windows XP (SP1 and SP2) supports only one scanner per system.</p>

Note: The use of portable or mobile communications equipment and/or the presence of strong electromagnetic and/or x-ray fields may interfere with proper operation of this product. This product should not be used adjacent to or stacked with other equipment. If adjacent or stacked use is necessary, verify normal operation in the configuration in which it will be used. Should such interference occur, the user is required to provide adequate isolation between the digitizer and the source of the interference. Isolation is typically achieved by moving the digitizer away from the source of the interference.

Weights and Dimensions

Shipping weight and dimensions

Shipping dimensions	24" wide x 29" deep x 24" high 610mm x 737mm x 610mm
Shipping weight	60 lb 27 kg

Digitizer weight and dimensions: DiagnosticPRO[®] Advantage and DosimetryPRO[®] Advantage

Overall dimensions	19" wide x 23" deep x 29.25" high 483mm x 584mm x 743mm
Footprint	19" wide x 23" deep 483mm x 584mm
Weight	45 lb 21 kg

Digitizer weight and dimensions: CAD PRO[®] Advantage

Overall dimensions	19" wide x 21.25" deep x 25.5" high 483mm x 540mm x 648mm
Footprint	19" wide x 21.25" deep 483mm x 540mm
Weight	45 lb 21 kg

Packing the Film Digitizer for Shipment

IMPORTANT: When shipping the film digitizer, you **must** use the original packing materials, including wire ties, plastic bags, plastic wrap, foam supports and cartons. Improper packaging may allow damage to the digitizer, which will incur additional charges for repair.

1. Turn Off the Digitizer

Press “0” on the power switch.

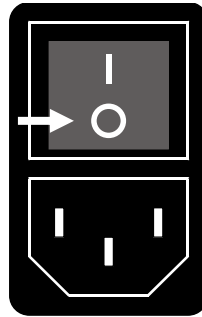

2. Disconnect the Power Cord and USB Cable

- Disconnect the power cord from the Power Entry Module on the rear of the digitizer.
- Disconnect the USB cable from the rear of the digitizer.

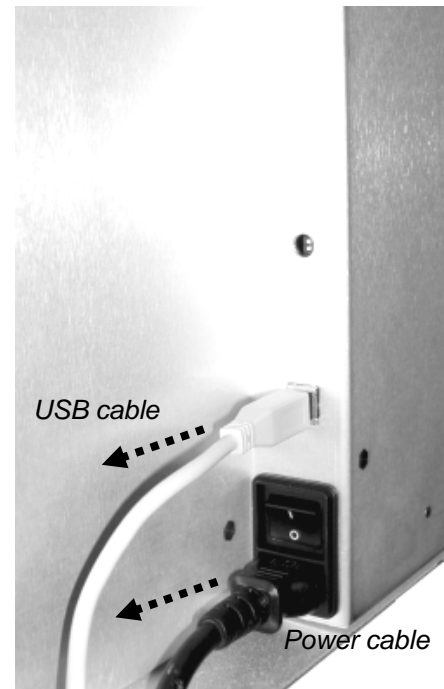

3. Remove the Exit Tray from the Digitizer Base

Lift the exit tray up to disengage it from the plastic edge just below the rollers, and then pull it gently toward you.

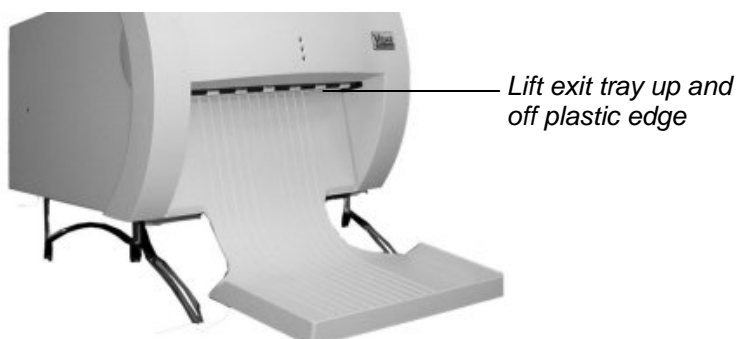

Removing DiagnosticPRO[®] Advantage and DosimetryPRO[®] Advantage exit tray

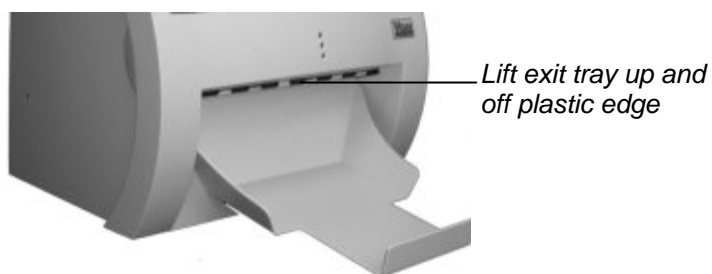

Removing CAD PRO[®] Advantage exit tray

4. Remove the Feeder from the Digitizer Base

- a. Remove the film support bar from the top of the feeder (DiagnosticPRO® Advantage and DosimetryPRO® Advantage ONLY).

Note: You must remove the film support before packing the feeder; otherwise the feeder will not fit into the foam support

Screws

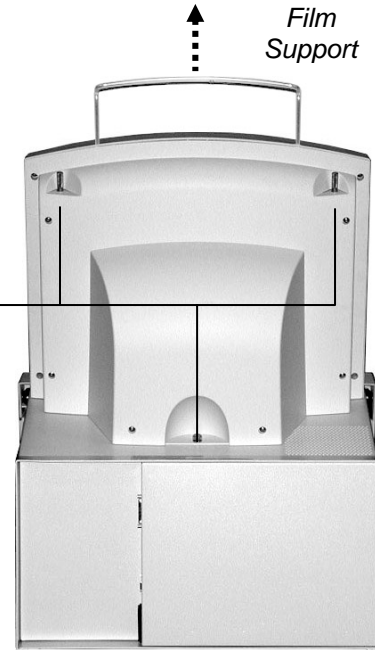

- b. Loosen the three thumbscrews securing the feeder to the digitizer base.

- c. Lift the feeder up and off the digitizer base.



5. Remove the Digitizer Base from the Stand

DiagnosticPRO[®] Advantage and DosimetryPRO[®] Advantage ONLY

Loosen the thumbscrews on the bottom of the stand, then lift the digitizer base from the stand.

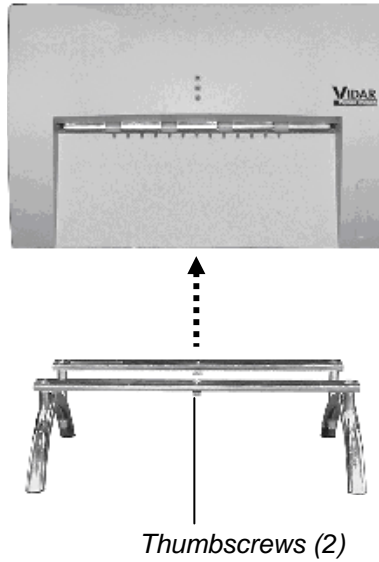

6. Prepare the Feeder

CAD PRO® Advantage ONLY

- a. Secure the film feeder Suction Cup Arm using the foam wedge as shown below.

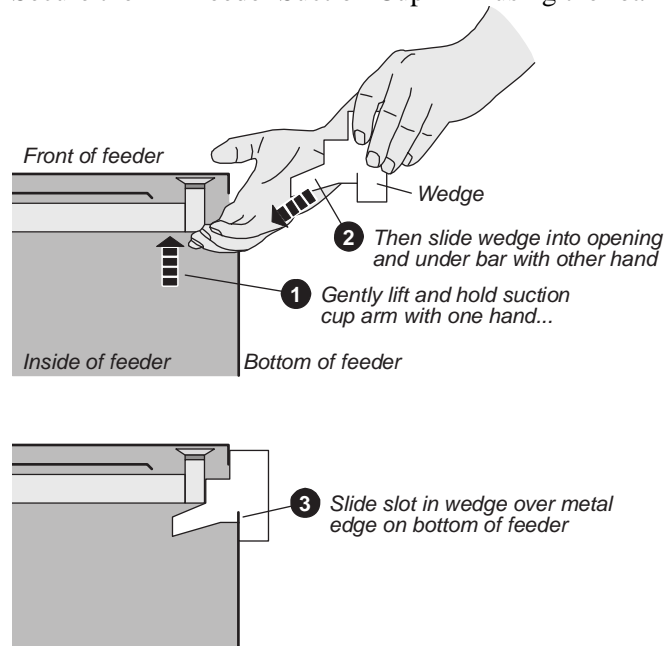

Feeder with wedge inserted should look like this:

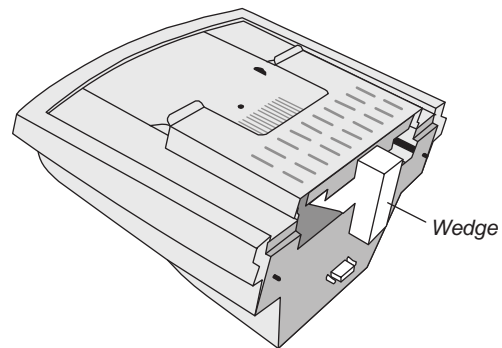

- b. Place the film feeder in a plastic bag. Seal the bag with tape.

7. Wrap Certain Items

- a. Insert the foam block in the rear of the digitizer base.

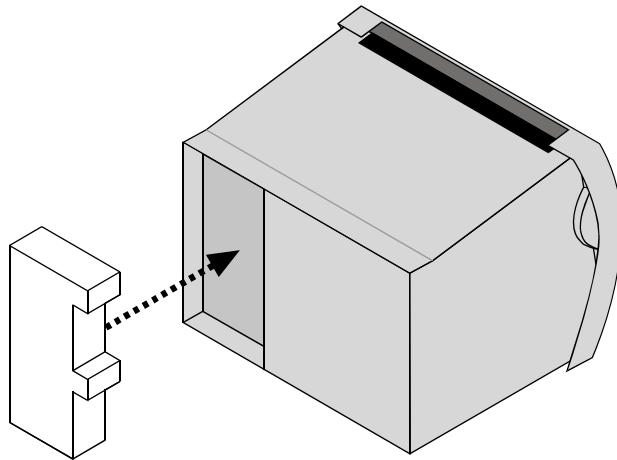

- b. Place the digitizer base in a plastic bag. Seal the bag with tape.
- c. Place the film feeder in a plastic bag. Seal the bag with tape.
- d. Place the exit tray in a plastic bag. Seal the bag with tape.
- e. Place the film support bar in a padded bag. Seal the bag with tape.

8. Pack the Accessory Box

DiagnosticPRO[®] Advantage and DosimetryPRO[®] Advantage ONLY

- a. Place these items in the accessory box in the order shown here. Orient the items as shown. When the cardboard retainer is in place, the two runners on the exit tray should protrude through the two slots in the retainer.

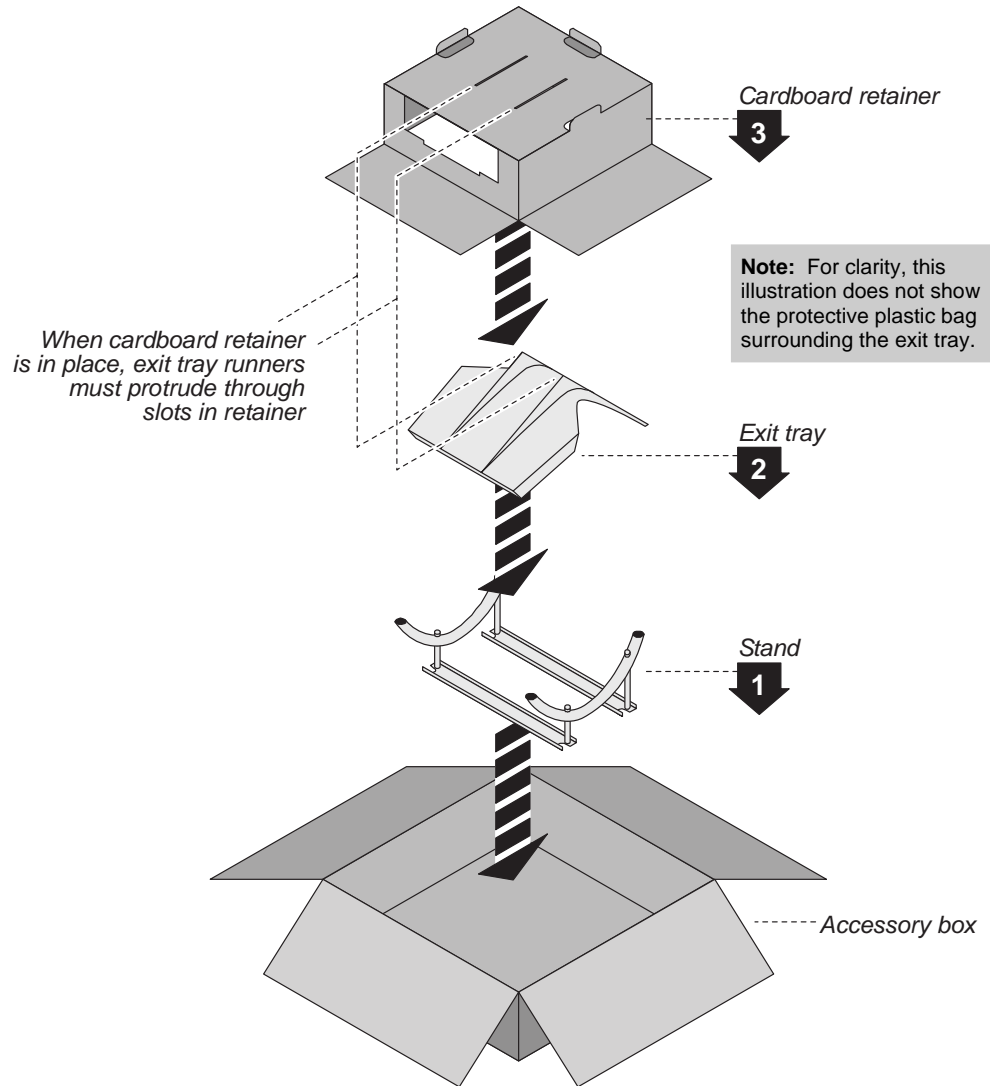

b. Place cables on the cardboard retainer:

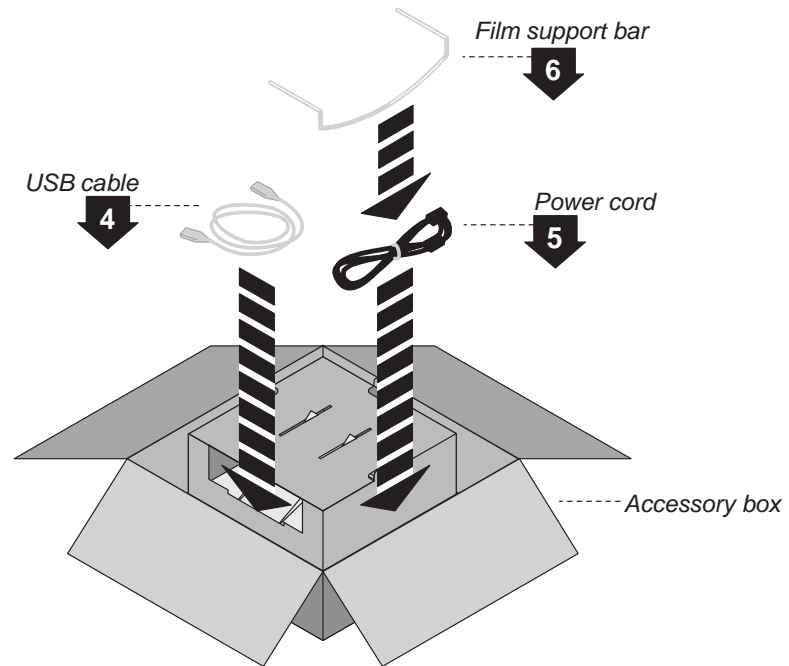

c. Close the accessory box and seal it with tape.

CAD PRO[®] Advantage ONLY

- a. Place these items in the accessory box in the order shown here. Orient the items as shown.

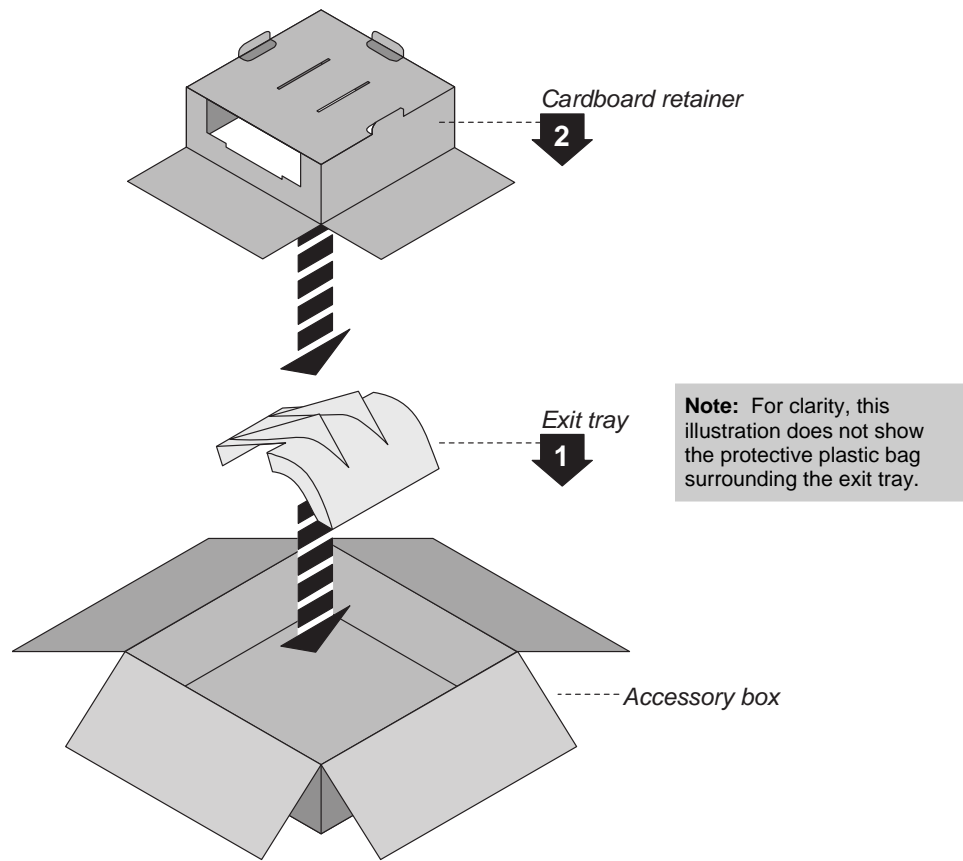

- b. Place cables on the cardboard retainer flap:

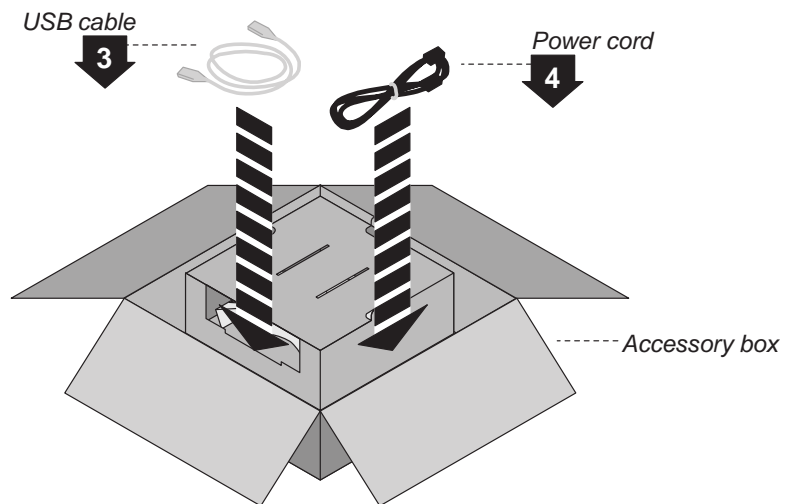

- c. Close the accessory box and seal it with tape.

9. Pack the Shipping Carton

- a. Place the items shown in the shipping carton, as shown here. Orient the items as shown.

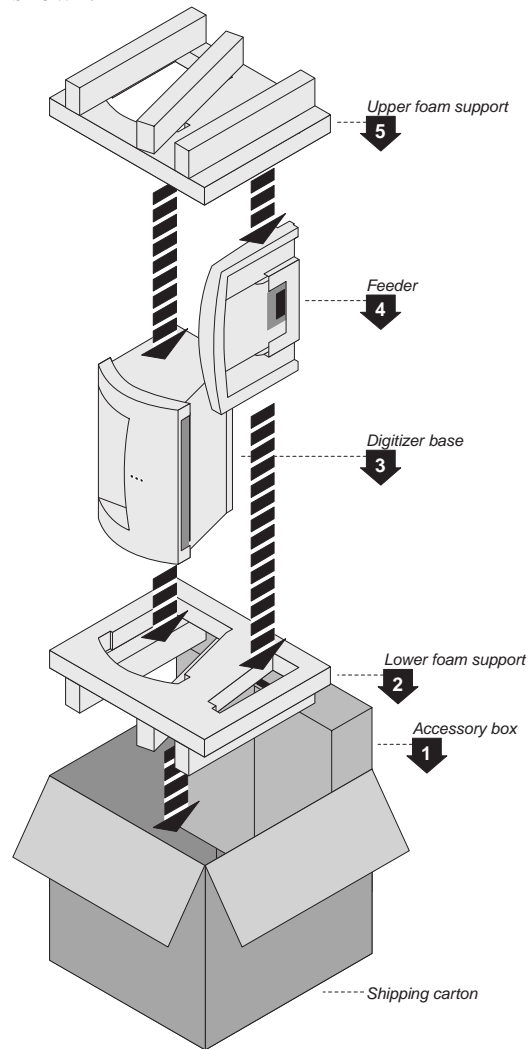

Note: For clarity, this illustration does not show the plastic bags surrounding the digitizer and feeder.

- b. Close the shipping carton and seal it with tape.

Note: If you are shipping the digitizer to VIDAR for repair or any other reason:

1. Obtain a Returned Materials Authorization (RMA) number by sending an e-mail request to medtech@VIDAR.com. Include the digitizer's serial number and the reason for return.
2. Write the RMA number on the box or shipping label. If the shipment does not have an RMA, processing will be delayed when it reaches VIDAR.

Appendix:

Electromagnetic Guidance

<p>Caution: Medical electrical equipment. EMC (Electro Magnetic Compatibility) must be considered before any medical electrical equipment is installed or put into service. Follow the information in the accompanying documentation when installing and operating the VIDAR Digitizer.</p>
<p>Caution: Portable or mobile RF communication equipment can effect Medical Electrical equipment.</p>
<p>Caution: Using the Digitizer adjacent to or stacked with other equipment may cause interference between the equipment. Before utilizing stacked or adjacent equipment, verify proper functionality of all equipment in the actual configuration in which it will operate.</p>
<p>Caution: Connecting the Digitizer to equipment that is not rated CISPR 11 class A or class B may alter the electromagnetic characteristics.</p>
<p>Caution: In a domestic environment this product may cause radio interference in which case the user may be required to take adequate measures.</p>

Guidance and manufacturer's declaration – electromagnetic equipment

Table 201

The DiagnosticPRO Advantage, DosimetryPRO Advantage (Red) and CAD PRO Advantage Digitizers are intended for use in the electromagnetic environment specified below. The customer or end user of the Digitizer should assure that it is used in such an environment.

Emissions test	Compliance	Electromagnetic environment - guidance
RF Emissions CISPR11	Group 1	The Digitizers use RF energy only for their internal functions. Therefore, its RF emissions are very low and are not likely to cause any interference in nearby electronic equipment.
RF Emissions, CISPR11	Class A	The Digitizers are suitable for use in all establishments other than domestic and those directly connected to the public low voltage power supply network that supplies buildings used for domestic purposes.
Harmonic Emissions IEC 61000-3-2	Class A	
Voltage Fluctuations/ flicker emissions IEC 61000-3-3	Complies	

Guidance And Manufacturer's Declaration – Electromagnetic Immunity

Table 202

The DiagnosticPRO Advantage, DosimetryPRO Advantage (Red) and CAD PRO Advantage Digitizers are intended for use in the electromagnetic environment specified below. The customer or end user of the Digitizer should assure that it is used in such an environment.

Immunity test	IEC 60601 test level	Compliance level	Electromagnetic environment - guidance
ElectroStatic Discharge (ESD) IEC 61000-4-2	+ 6 kV contact + 8 kV air	+ 6 kV contact + 8 kV air	Floors should be wood, concrete or ceramic tile. If floors are covered with synthetic material, the relative humidity should be at least 30%
Electrical fast transient/ burst IEC 61000-4-4	±2 kV for power supply lines ±1 kV for input/output lines	±2 kV for power supply lines ±1 kV for input/output lines	Mains power quality should be that of a typical commercial or hospital environment.
Surge IEC 61000-4-5	±1 kV differential mode ±2 kV common mode	±1 kV differential mode ±2 kV common mode	Mains power quality should be that of a typical commercial or hospital environment.
Voltage dips, short interruptions and voltage variations on power supply input lines IEC 61000-4-11	<5 % U _T (>95 % dip in U _T) for 0,5 cycle 40 % U _T (60 % dip in U _T) for 5 cycles 70 % U _T (30 % dip in U _T) for 25 cycles <5 % U _T (>95 % dip in U _T) for 5 sec	<5 % U _T (>95 % dip in U _T) for 0,5 cycle 40 % U _T (60 % dip in U _T) for 5 cycles 70 % U _T (30 % dip in U _T) for 25 cycles <5 % U _T (>95 % dip in U _T) for 5 sec	Mains power quality should be that of a typical commercial or hospital environment. If the user of the Digitizer requires continued operation during power mains interruptions, it is recommended that the Digitizer be powered from an uninterruptible power supply or a battery
Power frequency (50/60 Hz) magnetic field IEC 61000-4-8	3 A/m	3 A/m	Power frequency magnetic fields should be at levels characteristic of a typical location in a typical commercial or hospital environment.

NOTE: U_T is the A.C. mains voltage prior to application of the test level

Guidance And Manufacturer's Declaration – Electromagnetic Immunity

Table 204

The DiagnosticPRO Advantage, DosimetryPRO Advantage (Red) and CAD PRO Advantage Digitizers are intended for use in the electromagnetic environment specified below. The customer or end user of the Digitizer should assure that it is used in such an environment.

Immunity test	IEC 60601 test level	Compliance level	Electromagnetic environment - guidance
Conducted RF IEC 61000-4-6	3 Vrms 150 kHz to 80 MHz	3 V	<p>Portable and mobile RF communication equipment should be used no closer to any part of the Digitizer, including cables, than the recommended separation distance calculated from the equation applicable to the frequency of the transmitter. Recommended separation distance</p> $d = 1.2\sqrt{P}$
Radiated RF IEC 61000-4-3	3 V/m 80 MHz to 2,5 GHz	3 V/m	<p>$d = 1.2\sqrt{P}$ 80 MHz to 800 MHz $d = 2.3\sqrt{P}$ 800 MHz to 2.5 GHz</p> <p>Where P is the maximum output power rating of the transmitter in watts (W) according to the transmitter manufacturer and d is the recommended separation distance in meters (m). Field strengths from fixed RF transmitters, as determined by an electromagnetic site survey,^a should be less than the compliance level in each frequency range.^b Interference may occur in the vicinity of equipment marked with the following symbol:</p> <div style="text-align: center;">  </div>

Note 1: At 80MHz and 800MHz, the higher frequency range applies.

Note 2: These guidelines may not be applicable in all situations. Electromagnetic propagation is affected by absorption and reflection from structures, objects and people.

^a Field strengths from fixed transmitters, such as base stations for radio (cellular/cordless) telephones and land mobile radios, amateur radio, AM and FM radio broadcast and TV broadcast cannot be predicted theoretically with accuracy. To assess the electromagnetic environment due to fixed RF transmitters, an electromagnetic site survey should be considered. If the measured field strength in the location in which the Digitizer is used exceeds the applicable RF compliance level above, the Digitizer should be observed to verify normal operation. If abnormal performance is observed, additional measures may be necessary, such as reorienting or relocating the Digitizer.

^b Over the frequency range 150 kHz to 80 MHz, field strengths should be less than 3 V/m.

Recommended Separation Distances Between Portable And Mobile RF Communications Equipment And The Digitizer

Table 206

The DiagnosticPRO Advantage, DosimetryPRO Advantage (Red) and CAD PRO Advantage Digitizers are intended for use in an electromagnetic environment in which radiated RF disturbances are controlled. The customer or the user of the Digitizer can help prevent electromagnetic interference by maintaining a minimum distance between portable and mobile RF communications equipment (transmitters) and the Digitizer as recommended below, according to the maximum output power of the communications equipment.

Rated maximum output power of transmitter W	Separation distance according to frequency of transmitter, m		
	150 kHz to 80 MHz $d = 1.2\sqrt{P}$	80 MHz to 800 MHz $d = 1.2\sqrt{P}$	800 MHz to 2.5 GHz $d = 2.3\sqrt{P}$
0.01	0.12	0.12	0.23
0.1	0.37	0.37	0.74
1	1.2	1.2	2.3
10	3.7	3.7	7.4
100	12	12	23





For transmitters rated at a maximum output power not listed above, the recommended separation distance d in meters (m) can be estimated using the equation applicable to the frequency of the transmitter, where P is the maximum output power rating of the transmitter in watts (W) according to the transmitter manufacturer.

NOTE 1: At 80 MHz and 800 MHz, the separation distance for the higher frequency range applies.

NOTE 2: These guidelines may not apply in all situations. Electromagnetic propagation is affected by absorption and reflection from structures, objects and people.

Appendix:

Symbols

Symbol	Description
	Caution – See instructions for use
	Underwriters Laboratories listing symbol
	Compliance to EU Directives
	Authorized Representative in the European Community
	This symbol on the product indicates that this product must not be disposed of as unsorted municipal waste. Instead it is your responsibility to dispose of your waste equipment by handing it over to a designated collection point for recycling of waste electrical and electronic equipment. For more information about where you can dispose of your waste equipment for recycling please contact your local city office, your household waste disposal service or the shop where you purchased the product.

VIDAR Systems Corporation

**365 Herndon Parkway
Herndon, VA 20170
+1.703.471.7070 (Phone)
+1.703.471.7665 (Fax)
USA Toll Free: 800.471.SCAN**

www.vidar.com

