

## 3" DIAPHRAGM PUMP 1:1 RATIO (METALLIC)



**READ THIS MANUAL CAREFULLY BEFORE INSTALLING,  
OPERATING OR SERVICING THIS EQUIPMENT.**

It is the responsibility of the employer to place this information in the hands of the operator. Keep for future reference.

### SERVICE KITS

Refer to Model Chart to match the pump material options.  
637303-XX for Fluid Section Repair (see page 4). Note: This kit also contains several air motor seals which will need to be replaced.  
637302 for Air Section Repair (see page 6).

### PUMP DATA

**Models** . . . See Model Description Chart for "-XXX".  
**Pump Type** Metallic Air Operated Double Diaphragm  
**Material** . . . See Model Description Chart.  
**Weight** . . . Aluminum (wet end) . . . . . 102 lbs (46.3 kgs)  
                   Cast Iron (wet end) . . . . . 192.5 lbs (87.3 kgs)  
                   Hastelloy (wet end) . . . . . 193 lbs (87.5 kgs)  
                   Stainless Steel (wet end) . . 193 lbs (87.5 kgs)  
                   (add 36 lbs [16.3 kg] for stainless steel air motor section)  
**Maximum Air Inlet Pressure** . . . . . 120 p.s.i.g. (8.3 bar)  
**Maximum Material Inlet Pressure** . . . . . 10 p.s.i.g. (.69 bar)  
**Maximum Outlet Pressure** . . . . . 120 p.s.i.g. (8.3 bar)  
**Maximum Flow Rate (flooded inlet)** . . . . . 275 g.p.m. (1041 l.p.m.)  
**Displacement / Cycle @ 100 p.s.i.g.** . . . 2.8 gal. (10.6 l)  
**Maximum Particle Size** . . . . . 3/8" dia. (9.5 mm)  
**Maximum Temperature Limits** . . . . . 200°F (93°C)  
**Dimensional Data** . . . . . See page 8  
**Mounting Dimensions** . . . . . 12" x 13-1/2" (304.8 mm x 342.9 mm)  
**Noise Level @ 70 psi, 50 C.P.M.①** . . . . . 83.0 db(A)②

① Tested with 94085 muffler assembly installed.

② The pump sound pressure levels published here have been updated to an Equivalent Continuous Sound Level (L<sub>Aeq</sub>) to meet the intent of ANSI S1.13-1971, CAGI-PNEUROP S5.1 using four microphone locations.

**NOTICE: All possible options are shown in the chart however certain combinations may not be recommended, consult a representative or the factory if you have questions concerning availability.**

### GENERAL DESCRIPTION

The ARO Diaphragm Pump offers high volume delivery even at low air pressure and a broad range of material compatibility options available. Refer to the model and option chart. ARO pumps feature stall resistant design, modular air motor / fluid sections.

Air operated double diaphragm pumps utilize a pressure differential in the air chambers to alternately create suction and positive fluid pressure in the fluid chambers, ball checks insure a positive flow of fluid.

Pump cycling will begin as air pressure is applied and it will continue to pump and keep up with the demand. It will build and maintain line pressure and will stop cycling once maximum line pressure is reached (dispensing device closed) and will resume pumping as needed.

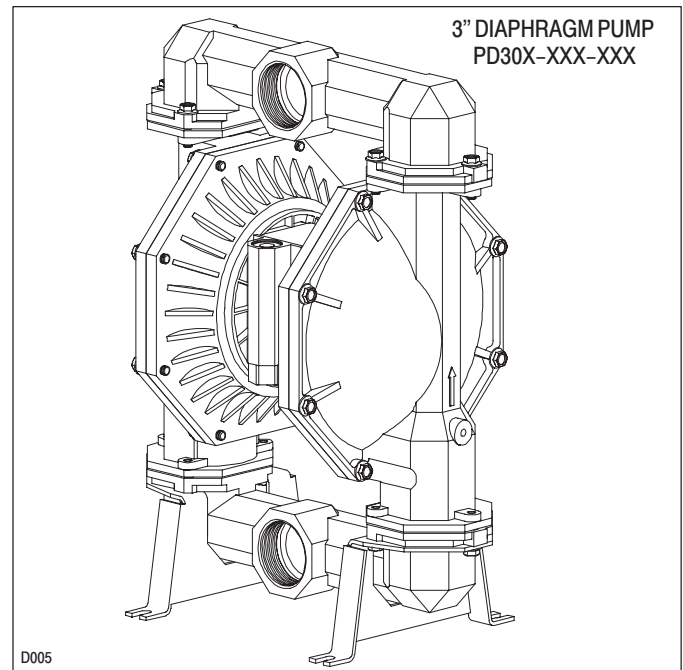

### MODEL DESCRIPTION CHART

PD30 X - X X X - X X X	
<b>CENTER SECTION MATERIAL</b> A - Aluminum S - Stainless Steel	
<b>THREAD</b> A - NPT B - BSP	
<b>FLUID CAPS &amp; MANIFOLD MATERIAL</b> A - Aluminum H - Hastelloy C - Cast Iron S - Stainless Steel	
<b>HARDWARE MATERIAL</b> P - Plated Steel S - Stainless Steel	
<b>SEAT MATERIAL</b> A - Santoprene® K - PVDF (Kynar®) G - Geolast® S - 316 Stainless Steel H - Hard 440 Stainless Steel	
<b>BALL MATERIAL</b> A - Santoprene G - Geolast T - PTFE	
<b>DIAPHRAGM MATERIAL</b> A - Santoprene G - Geolast T - PTFE	
<b>FLUID SECTION SERVICE KIT SELECTION</b> PD30X - XXX - X X X	
EXAMPLE: MODEL # PD30A-ACS-SAA 637303 - <input checked="" type="checkbox"/> <input checked="" type="checkbox"/> <input checked="" type="checkbox"/>	
FLUID SECTION SERVICE KIT # 637303-AA BALL <input type="checkbox"/> <input type="checkbox"/> DIAPHRAGM	

## OPERATING AND SAFETY PRECAUTIONS

READ, UNDERSTAND, AND FOLLOW THIS INFORMATION TO AVOID INJURY AND PROPERTY DAMAGE.



**⚠ WARNING** EXCESSIVE AIR PRESSURE. Can cause personal injury, pump damage or property damage.

- Do not exceed the maximum inlet air pressure as stated on the pump model plate.
- Be sure material hoses and other components are able to withstand fluid pressures developed by this pump. Check all hoses for damage or wear. Be certain dispensing device is clean and in proper working condition.

**⚠ WARNING** STATIC SPARK. Can cause explosion resulting in severe injury or death. Ground pump and pumping system.

- Use the pump grounding screw terminal provided. Use Aro Part No. 66885-1 Ground Kit or connect a suitable ground wire (12 ga. min.) to a good earth ground source.
- Secure pump, connections and all contact points to avoid vibration and generation of contact or static spark.
- Consult local building codes and electrical codes for specific grounding requirements.
- After grounding, periodically verify continuity of electrical path to ground. Test with an ohmmeter from each component (e.g., hoses, pump, clamps, container, spray gun, etc.) to ground to insure continuity. Ohmmeter should show 100 ohms or less.
- Submerge the outlet hose end, dispensing valve or device in the material being dispensed if possible. (Avoid free streaming of material being dispensed.)
- Use hoses incorporating a static wire.
- Use proper ventilation.
- Keep inflammables away from heat, open flames and sparks.
- Keep containers closed when not in use.

**⚠ WARNING** Pump exhaust may contain contaminants. Can cause severe injury. Pipe exhaust away from work area and personnel.

- In the event of a diaphragm rupture material can be forced out of the air exhaust muffler.
- Pipe the exhaust to a safe remote location when pumping hazardous or inflammable materials.
- Use a grounded 1" min. i.d. hose between the pump and the muffler.

**⚠ WARNING** HAZARDOUS PRESSURE. Can result in serious injury or property damage. Do not service or clean pump, hoses or dispensing valve while the system is pressurized.

- Disconnect air supply line and relieve pressure from the system by opening dispensing valve or device and/or carefully and slowly loosening and removing outlet hose or piping from pump.

**⚠ WARNING** HAZARDOUS MATERIALS. Can cause serious injury or property damage. Do not attempt to return a pump to the factory or service center that contains hazardous material. Safe handling practices must comply with local and national laws and safety code requirements.

- Obtain Material Safety Data Sheets on all materials from the supplier for proper handling instructions.

**⚠ WARNING** EXPLOSION HAZARD. Models containing aluminum wetted parts cannot be used with Ill.-Trichloroethane, Methylene Chloride or other Halogenated Hydrocarbon solvents which may react and explode.

- Check pump motor section, fluid caps, manifolds and all wetted parts to assure compatibility before using with solvents of this type.

**⚠ WARNING** MISAPPLICATION HAZARD. Do not use models containing aluminum wetted parts with food products for human consumption. Plated parts can contain trace amounts of lead.

**⚠ CAUTION** Verify the chemical compatibility of the pump wetted parts and the substance being pumped, flushed or recirculated. Chemical compatibility may change with temperature and concentration of the chemical(s) within the substances being pumped, flushed or circulated. Consult the material manufacturer and ARO Form No. 8677-P, Fluid Compatibility Guide, for information on chemical compatibility.

**⚠ CAUTION** Maximum temperatures are based on mechanical stress only. Certain chemicals will significantly reduce maximum safe operating temperature. Consult Fluid Compatibility Guide for chemical compatibility and temperature limits. Refer to PUMP DATA on page 1 of this manual.

**⚠ CAUTION** Be certain all operators of this equipment have been trained for safe working practices, understand it's limitations, and wear safety goggles/equipment when required.

**⚠ CAUTION** Do not use the pump for the structural support of the piping system. Be certain the system components are properly supported to prevent stress on the pump parts.

- Suction and discharge connections should be flexible connections (such as hose), not rigid piped, and should be compatible with the substance being pumped.

**⚠ CAUTION** Prevent unnecessary damage to the pump. Do not allow pump to operate when out of material for long periods of time.

- Disconnect air line from pump when system sits idle for long periods of time.

**⚠ CAUTION** Use only genuine ARO replacement parts to assure compatible pressure rating and longest service life.

**⚠ WARNING** = Hazards or unsafe practices which could result in severe personal injury, death or substantial property damage.

**⚠ CAUTION** = Hazards or unsafe practices which could result in minor personal injury, product or property damage.

**NOTICE** = Important installation, operation or maintenance information.

---

---

## AIR AND LUBE REQUIREMENTS

---

**⚠ WARNING** EXCESSIVE AIR PRESSURE. Can cause pump damage, personal injury or property damage.

- A filter capable of filtering out particles larger than 50 microns should be used on the air supply. In most applications there is no lubrication required other than the “O” ring lubricant which is applied during assembly or repair.
- When lubricated air is necessary, supply the air lubricator with a good grade of SAE 90 wt. non-detergent oil and set the lubricator to a rate not to exceed one drop per minute.

---

---

## OPERATING INSTRUCTIONS

---

- Always flush the pump with a solvent compatible with the material being pumped if the material being pumped is subject to “setting up” when not in use for a period of time.
- Disconnect the air supply from the pump if it is to be inactive for a few hours.
- The outlet material volume is governed not only by the air supply but also by the material supply available at the inlet. The material supply tubing should not be too small or restrictive. Be sure not to use hose which might collapse.
- When the diaphragm pump is used in a forced-feed (flooded inlet) situation it is recommended that a “Check Valve” be installed at the air inlet.
- Secure the diaphragm pump legs to a suitable surface to insure against damage by vibration.

---

---

## MAINTENANCE

---

Refer to the part views and descriptions as provided on page 4 through 7 for parts identification and Service Kit information.

- Certain ARO “Smart Parts” are indicated which should be available for fast repair and reduction of down time.
- Service kits are divided to service two separate diaphragm pump functions: 1. AIR SECTION, 2. FLUID SECTION. The FLUID SECTION is divided further to match typical part MATERIAL OPTIONS.

---

---

## MAINTENANCE (CONT'D)

---

- Provide a clean work surface to protect sensitive internal moving parts from contamination from dirt and foreign matter during service disassembly and reassembly.
- Keep good records of service activity and include pump in preventive maintenance program.
- Before disassembling empty captured material in the outlet manifold by turning the pump upside down to drain material from the pump.

---

---

## FLUID SECTION DISASSEMBLY

---

1. Remove top manifold(s).
2. Remove (22) balls, (19) “O” rings and (21) seats.
3. Remove (15) fluid caps.

NOTE: Only PTFE diaphragm models use a primary (7) diaphragm and a backup (8) diaphragm. Refer to the auxiliary view. Fig.1

4. Remove the (6) nut, (7) or (7/8) diaphragms and (5) washer.

NOTE: Do not scratch or mar the surface of (1) diaphragm rod.

---

---

## FLUID SECTION REASSEMBLY

---

SERVICE NOTE: ARO PN 204214-T Diaphragm Assembly Tool is recommended for use when reassembling the pump.

- Reassemble in reverse order.
- Clean and inspect all parts. Replace worn or damaged parts with new parts as required.
- Lubricate (1) diaphragm rod and (144) “U” cup with Lubriplate FML-2 Grease. (94276 grease packet is included in service kit.)
- Be certain the diaphragm assembly bottoms out on the (1) rod, back off Teflon Diaphragm assembly far enough to align holes.
- For models with Teflon diaphragms: Item (8) Santoprene diaphragm is installed with the side marked “AIR SIDE” towards the pump center body. Install the (7) PTFE Diaphragm with the side marked “FLUID SIDE” towards the fluid cap.
- Re-check torque settings after pump has been re-started and run a while.

## PARTS LIST / PD30X-X FLUID SECTION

### FLUID SECTION SERVICE KITS (637303-XX)

★ KITS INCLUDE: BALLS (See Ball Option, refer to -XX in chart below), DIAPHRAGMS (See Diaphragm Option, refer to -XX in chart below), and items; 19, 70, 144, 175, (listed below) plus (174) and 94276 Lubriplate FML-2 grease (page 6).

#### SEAT OPTIONS PD30X-XXX-XXX

"21"			★ "19"			"21"			★ "19"		
-XXX	SEAT (4)	[MTL]	GASKET	QTY	[MTL]	-XXX	SEAT (4)	[MTL]	GASKET	QTY	[MTL]
-AXX	94104-A	[SP]	-----	---	---	-KXX	94621-K	[K]	Y328-350	(4)	[T]
-GXX	94104-G	[G]	-----	---	---	-SGX	94113	[SS]	Y325-350	(8)	[B]
-HGX	94114	[SH]	Y325-350	(8)	[B]	-SAX	94113	[SS]	94115	(8)	[E]
-HAX	94114	[SH]	94115	(8)	[E]	-STX	94113	[SS]	Y328-350	(8)	[T]
-HTX	94114	[SH]	Y328-350	(8)	[T]						

#### BALL OPTIONS PD30X-XXX-XXX

★ "22" (3.25" dia.)		
-XXX	BALL (4)	[MTL]
-XAX	94103-A	[SP]
-XGX	94103-G	[G]
-XTX	94103-T	[T]

#### DIAPHRAGM OPTIONS PD30X-XXX-XXX

-XXX	★ SERVICE KIT	★ "7" / "8"	
	-XX = (Ball) -X $\bar{X}$ = (Diaphragm)	DIAPHRAGM (2)	[MTL]
-XXA	637303-XA	94091-A	[SP]
-XXG	637303-XG	94091-G	[G]
-XXT	637303-XT	94090-T / 94110-A	[T/SP]

#### MATERIAL CODE

[A] = Aluminum  
 [B] = Buna "N"  
 [C] = Carbon Steel  
 [Co] = Copper  
 [Cl] = Cast Iron  
 [E] = E.P.R.  
 [G] = Geolast  
 [Ha] = Hastelloy - C  
 [K] = PVDF  
 [SH] = Hard S'Steel  
 [SP] = Santoprene  
 [SS] = Stainless Steel  
 [T] = PTFE

#### CENTER SECTION PART OPTIONS PD30X-

ITEM	DESCRIPTION (SIZE IN INCHES)	QTY	PD30A-		PD30S-	
			PART NO.	[MTL]	PART NO.	[MTL]
5	Backup Washer	(2)	66167	[SS]	66167	[SS]
32	Leg	(2)	94101-1	[C]	94101-2	[SS]
68	Air Cap	(1)	94030-1	[A]	94031-1	[SS]
69	Air Cap	(1)	94030-2	[A]	94031-2	[SS]
★ 175	"O" Ring (3/32" x 1" o.d. / 1-1/16" o.d.)	(2)	Y325-117 $\circ$	[B]	Y325-118 $\circ$	[B]

#### MANIFOLD THREAD / FLUID CAP MATERIAL OPTIONS PD30X-XXX-

ITEM	DESCRIPTION	QTY	PD30X-XAX-		PD30X-XCX-		PD30X-XHX-		PD30X-XSX-	
			PART NO.	[MTL]	PART NO.	[MTL]	PART NO.	[MTL]	PART NO.	[MTL]
6	Diaphragm Screw	(2)	94096	[A]	94094	[SS]	94690	[Ha]	94094	[SS]
15	Fluid Cap	(2)	94024	[A]	94106	[Cl]	94693	[Ha]	94107	[SS]
60	Outlet Manifold	(1)	94118-[ $\infty$ ]	[A]	94105-[ $\infty$ ]	[Cl]	94692-[ $\infty$ ]	[Ha]	94116-[ $\infty$ ]	[SS]
61	Inlet Manifold	(1)	94218-[ $\infty$ ]	[A]	94305-[ $\infty$ ]	[Cl]	94691-[ $\infty$ ]	[Ha]	94216-[ $\infty$ ]	[SS]

$\infty$  For NPT models (PD30X-AXX-XXX), use "-1" For BSP models (PD30X-BXX-XXX), use "-2".

#### EXTERNAL HARDWARE OPTION PD30X-XXX-

ITEM	DESCRIPTION (SIZE IN INCHES)	QTY	PD30X-XXP-		PD30X-XXS-	
			PART NO.	[MTL]	PART NO.	[MTL]
26	Screw (M12 x 1.75 - 6g x 45 mm)	(28)	94412-1	[C]	94412-2	[SS]

#### COMMON PARTS

ITEM	DESCRIPTION (Size in Inches)	QTY	PART NO.	[MTL]	ITEM	DESCRIPTION (Size in Inches)	QTY	PART NO.	[MTL]
1	Rod	(1)	94093	[C]	131	Screw (M10 x 1.5 - 6g x 120 mm)	(4)	94531	[C]
43	Ground Lug	(1)	93004	[Co]	★ 144	"U" Cup (3/16" x 1-3/8" o.d.)	(2)	Y186-51	[B]
★ 70	Gasket	(2)	94100	[B]	180	Gasket (.406" i.d. x .031" thick)	(4)	94098	[Co]

"Smart Parts" keep these items on hand in addition to the Service Kits for fast repair and reduction of down time.

# PARTS LIST / PD30X-X FLUID SECTION

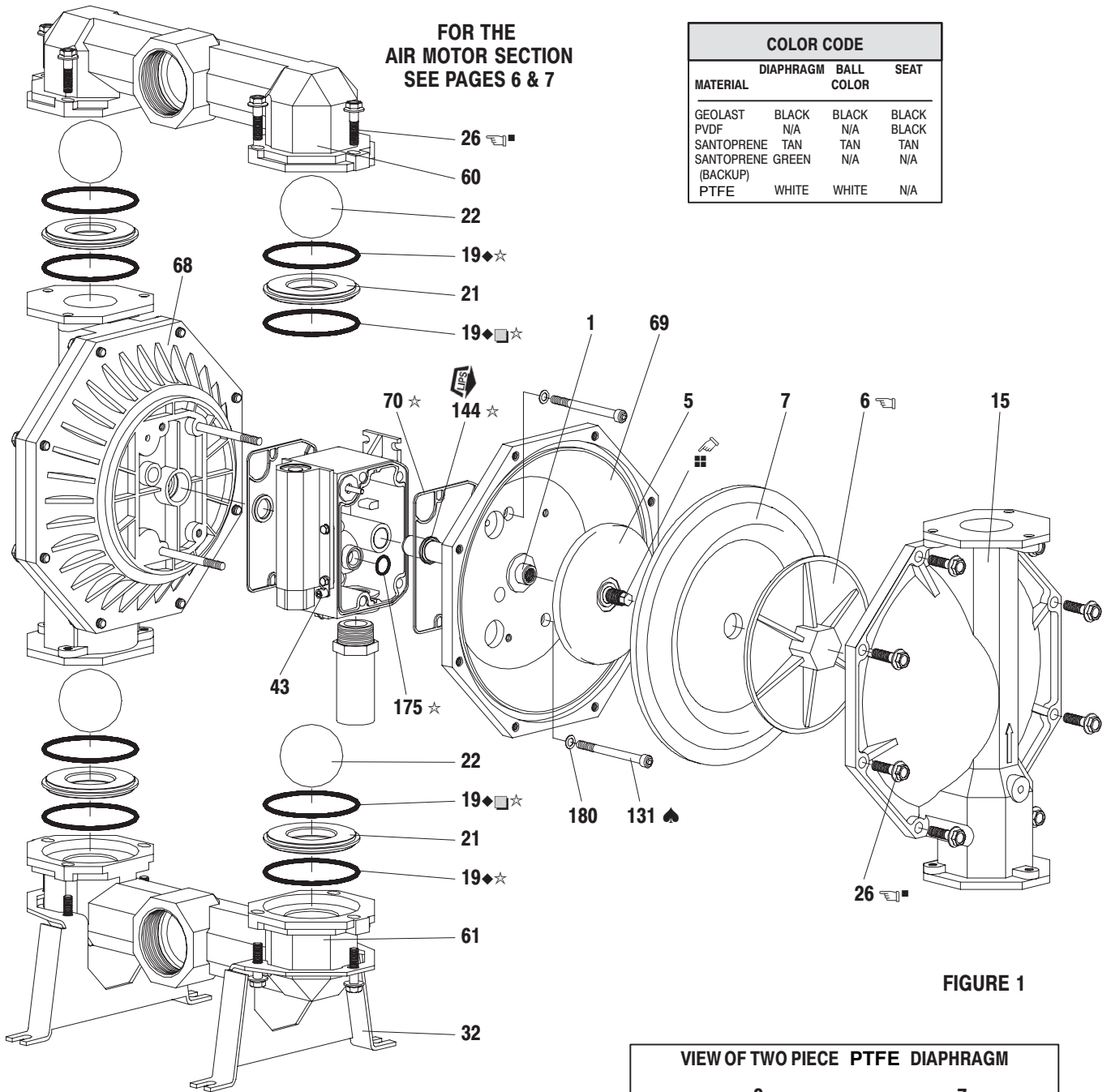

FOR THE  
AIR MOTOR SECTION  
SEE PAGES 6 & 7

COLOR CODE			
MATERIAL	DIAPHRAGM	BALL COLOR	SEAT
GEOLAST	BLACK	BLACK	BLACK
PVDF	N/A	N/A	BLACK
SANTOPRENE	TAN	TAN	TAN
SANTOPRENE (BACKUP)	GREEN	N/A	N/A
PTFE	WHITE	WHITE	N/A

FIGURE 1

**TORQUE REQUIREMENTS**  
**NOTE: DO NOT OVERTIGHTEN FASTENERS**  
**ALL FASTENERS ARE METRIC**  
 (6) Diaphragm Screw 60 - 70 ft lbs (81.4 - 94.9 Nm)  
 (26) Fluid Caps / Manifold Screw 60 - 70 ft lbs (81.4 - 94.9 Nm),  
 ■ Do not exceed 90 ft lbs (122 Nm) on (5) stud and apply Loctite 271 to threads.  
 ■ Apply anti-seize compound to threads when using SS fasteners and stainless steel wet ends.

**LUBRICATION / SEALANTS**  
 ☆ Apply Lubriplate FML-2 Grease to all "O" rings, "U" Cups & mating parts.  
 ■ USED WITH -HXX, KXX & -SXX ONLY  
 ◆ USED WITH -HXX & -SXX ONLY  
 ♠ Apply Loctite 242 to threads at assembly.

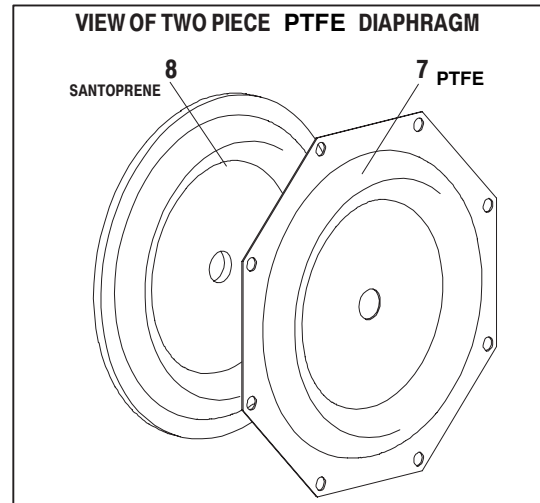

## PARTS LIST / PD30X-X AIR SECTION

✓ Indicates parts included in 637302 Air Section Service Kit shown below and items (70), (144), (175) and (180) shown on page 4.

### AIR MOTOR PARTS

ITEM	DESCRIPTION (Size in Inches)	QTY	PART NO.	[MTL]
101	Center Body (PD30A-)	(1)	94028	[A]
	Center Body (PD30S-)	(1)	94109	[SS]
103	Bushing	(1)	94092	[D]
107	Inlet Plug	(1)	94034	[C]
109	Piston	(1)	92011	[D]
✓ 110	“U” Cup (1-3/8” o.d.) (Also Item #144)	(1)	Y186-51	[B]
111	Spool (PD30A-)	(1)	92005	[A]
	Spool (PD30S-)	(1)	93047	[C]
112	Washer (1.556” o.d.)	(5)	92877	[Z]
✓ 113	“O” Ring (small) (1/8” x 1-1/4” o.d.)	(5)	Y325-214	[B]
✓ 114	“O” Ring (large) (3/32” x 1-9/16” o.d.)	(7)	Y325-126	[B]
□ 115	Spacer	(4)	92876	[Z]
116	Spacer	(1)	94027	[A]
118	Actuator Pin (.250” x 2.276”)	(2)	94083	[SS]
121	Sleeve	(2)	94084	[D]
✓ 132	Gasket (Valve Body)	(1)	94099	[B]
133	Lockwasher (1/4”) (PD30A-)	(3)	Y117-416-C	[C]
	Lockwasher (1/4”) (PD30S-)	(3)	Y14-416-T	[SS]
134	Screw (M6 x 1.0 x 16 mm) (PD30A-)	(4)	96721030	[C]
	Screw (M6 x 1.0 x 16 mm) (PD30S-)	(4)	96720081	[SS]

ITEM	DESCRIPTION (Size In Inches)	QTY	PART NO.	[MTL]
135	Valve Block (PD30A-)	(1)	94032	[A]
	Valve Block (PD30S-)	(1)	94318	[SS]
136	Piston Plug	(1)	94033	[D]
✓ 146	“O” Ring ◆ (3/32” x 1-1/16” o.d.)	(1)	Y325-118	[B]
✓ 147	“O” Ring ◆ (1/8” x 1/2” o.d.) Also #174	(2)	Y325-202	[B]
✓ 166	Track Gasket ●	(1)	94026	[B]
✓ 167	Pilot Piston (includes 168 and 169)	(1)	67164	[D]
168	“O” Ring (3/32” x 5/8” o.d.)	(2)	94433	[U]
169	“U” Cup (1/8” x 7/8” o.d.)	(1)	Y240-9	[B]
170	Piston Sleeve	(1)	94081	[Br]
✓ 171	“O” Ring (3/32” x 1-1/8” o.d.)	(1)	Y325-119	[B]
✓ 172	“O” Ring (1/16” x 1-1/8” o.d.)	(1)	Y325-22	[B]
✓ 173	“O” Ring (1/16” x 1-3/8” o.d.)	(2)	Y325-26	[B]
★ ✓ 174	“O” Ring (1/8” x 1/2” o.d.)	(2)	Y325-202	[B]
✓ 176	Diaphragm (Check Valve)	(2)	94102	[U]
✓ 177	Retaining Ring (1.804” dia.)	(1)	Y147-16-C	[C]
181	Roll Pin ◆ (.156” o.d. x 3/4” long)	(4)	Y178-56-S	[SS]
★ ✓	Lubriplate FML-2 Grease	(1)	94276	
	Lubriplate Grease Packets (10)		637308	
◆ Used on Stainless Steel models (PD30S-) only.				
● Used on Aluminum models (PD30A-) only.				

### AIR MOTOR SECTION SERVICE

Service is divided into two parts - 1.Pilot Valve, 2.Major Valve.

#### GENERAL REASSEMBLY NOTES:

- Air Motor Section Service is continued from Fluid Section repair.
- Inspect and replace old parts with new parts as necessary. Look for deep scratches on metallic surfaces, and nicks or cuts in “O” rings.
- Take precautions to prevent cutting “O” rings upon installation.
- Lubricate “O” rings with Lubriplate FML-2 Grease.
- Do not over-tighten fasteners, refer to torque specification block on view.
- Re-torque fasteners following restart.
- SERVICE TOOLS - To aid in the installation of (168) “O” rings onto the (167) pilot piston, use Tool # 204130-T, available from Aro.

### PILOT VALVE DISASSEMBLY

1. A light tap on (118) should expose the opposite (121) sleeve, (167) pilot piston and other parts.
2. Remove (170) sleeve, inspect inner bore of sleeve for damage.

### PILOT VALVE REASSEMBLY

1. Clean and lubricate parts not being replaced from service kit.
2. Install new (171), (172) “O” rings, replace (170) sleeve.
3. Install new (168) “O” rings, (169) seal - Note the lip direction. Lubricate and replace (167).
4. Reassemble remaining parts, replace (173) and (174) “O” rings.

□ “Smart Parts” Keep these items on hand in addition to the Service Kits for fast repair and reduction of down time.

#### MATERIAL CODE

[A] = Aluminum	[CI] = Cast Iron	[SS] = Stainless Steel
[B] = Buna “N”	[D] = Acetal	[U] = Polyurethane
[Br] = Brass	[SP] = Santoprene	[Z] = Zinc
[C] = Carbon Steel		

### MAJOR VALVE DISASSEMBLY

1. Remove (135) valve block exposing gaskets (166), (132) and (176) checks.
2. Remove (177) snap ring and (107) inlet plug.
3. On the side opposite the air inlet, push on the inner diameter (111) spool. This will force the (136) piston plug and (109) piston out. Continue pushing the (111) spool and remove. Check for scratches or gouges.
4. Remove the Major Valve parts (112-116).

### MAJOR VALVE REASSEMBLY

1. Replace (112) washer, (114) “O” ring, (113) “O” ring onto (115) spacer and insert etc. Continue this routine to build the major valve stack.
- NOTE: Be careful to orient spacer legs away from blocking internal ports.**
2. Replace (111) spool on (136) plug, (110) seal on (109) piston and replace (109), (136) plug and (177) snap ring.

# PARTS LIST / PD30X-X AIR SECTION

## MAJOR VALVE CROSS SECTION DETAIL

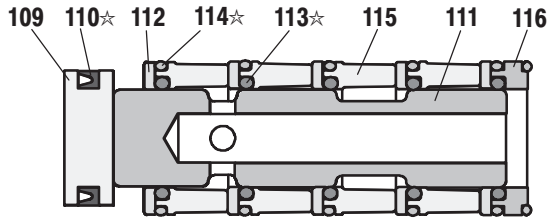
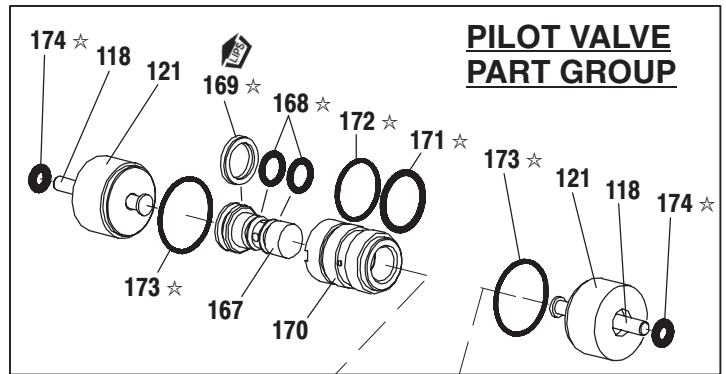

FIGURE 3



## PILOT VALVE PART GROUP

◆ Substitute these "O" rings for "166" on models PD30S.

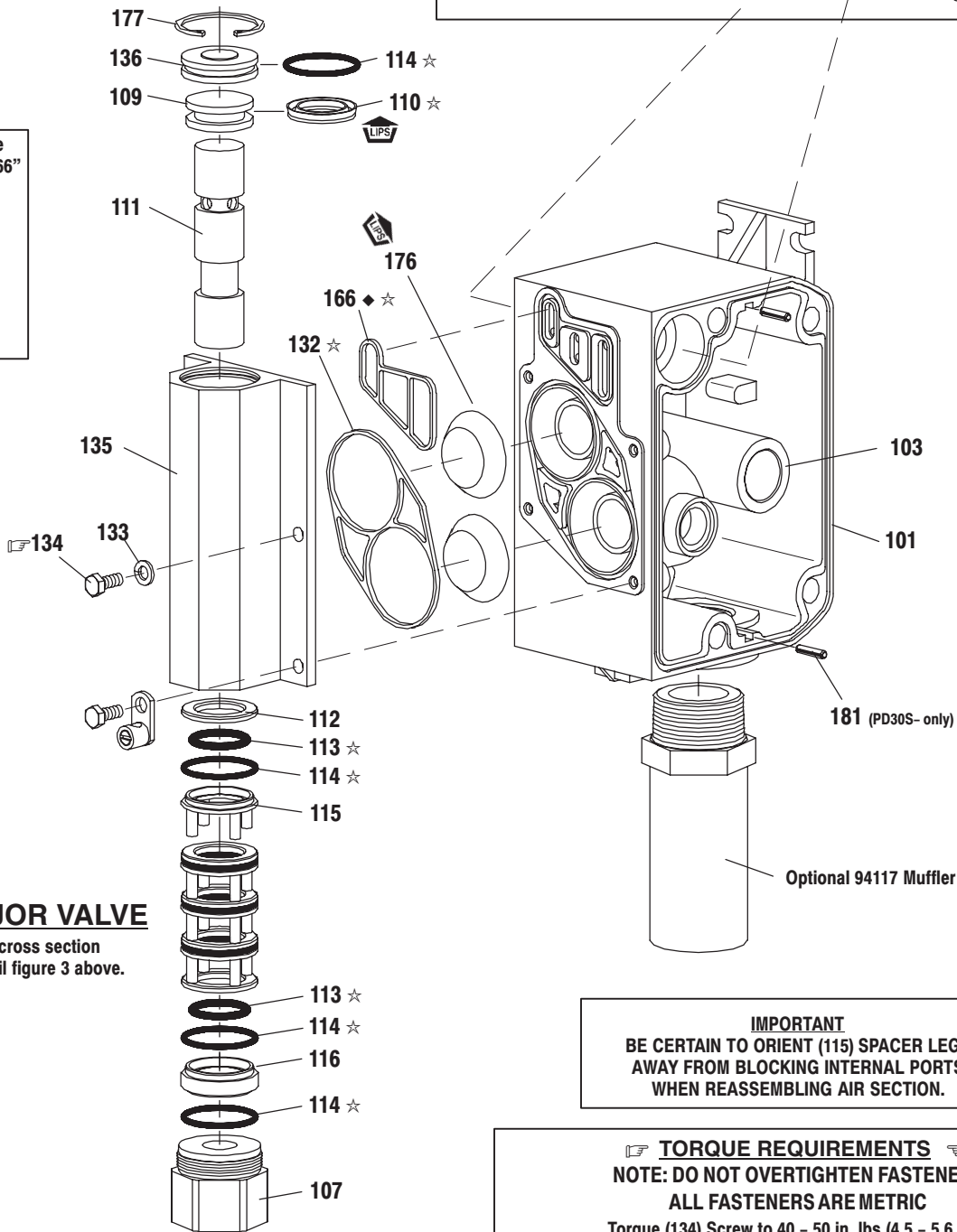

FIGURE 2

## MAJOR VALVE

See cross section detail figure 3 above.

A Major Valve Service Asm. is available separately which includes the following.	
Valve Asm. Pump Models	Items Included
67089-1 PD30A-	107-116,132,135,136,166,176,177
67089-2 PD30S-	107-116,132,135,136,146,147,176,177

## TROUBLE SHOOTING

### Product discharged from exhaust outlet.

- Check for diaphragm rupture.
- Check tightness of diaphragm nut.

### Air bubbles in product discharge.

- Check connections of suction plumbing.
- Check "O" rings between intake manifold and fluid caps.
- Check tightness of diaphragm nut.

### Motor blows air or stalls.

- Check (176) check valve for damage or wear.
- Check for restrictions in valve / exhaust.

### Low output volume, erratic flow, or no flow.

- Check air supply.
- Check for plugged outlet hose.
- Check for kinked (restrictive) outlet material hose.
- Check for kinked (restrictive) or collapsed inlet material hose.
- Check for pump cavitation – suction pipe should be sized at least as large as the inlet thread diameter of the pump for proper flow if high viscosity fluids are being pumped. Suction hose must be a non-collapsing type, capable of pulling a high vacuum.
- Check all joints on the inlet manifolds and suction connections. These must be air tight.
- Inspect the pump for solid objects logged in the diaphragm chamber or the seat area.

## DIMENSIONAL DATA

(Dimensions shown are for reference only, they are displayed in inches and millimeters (mm).)

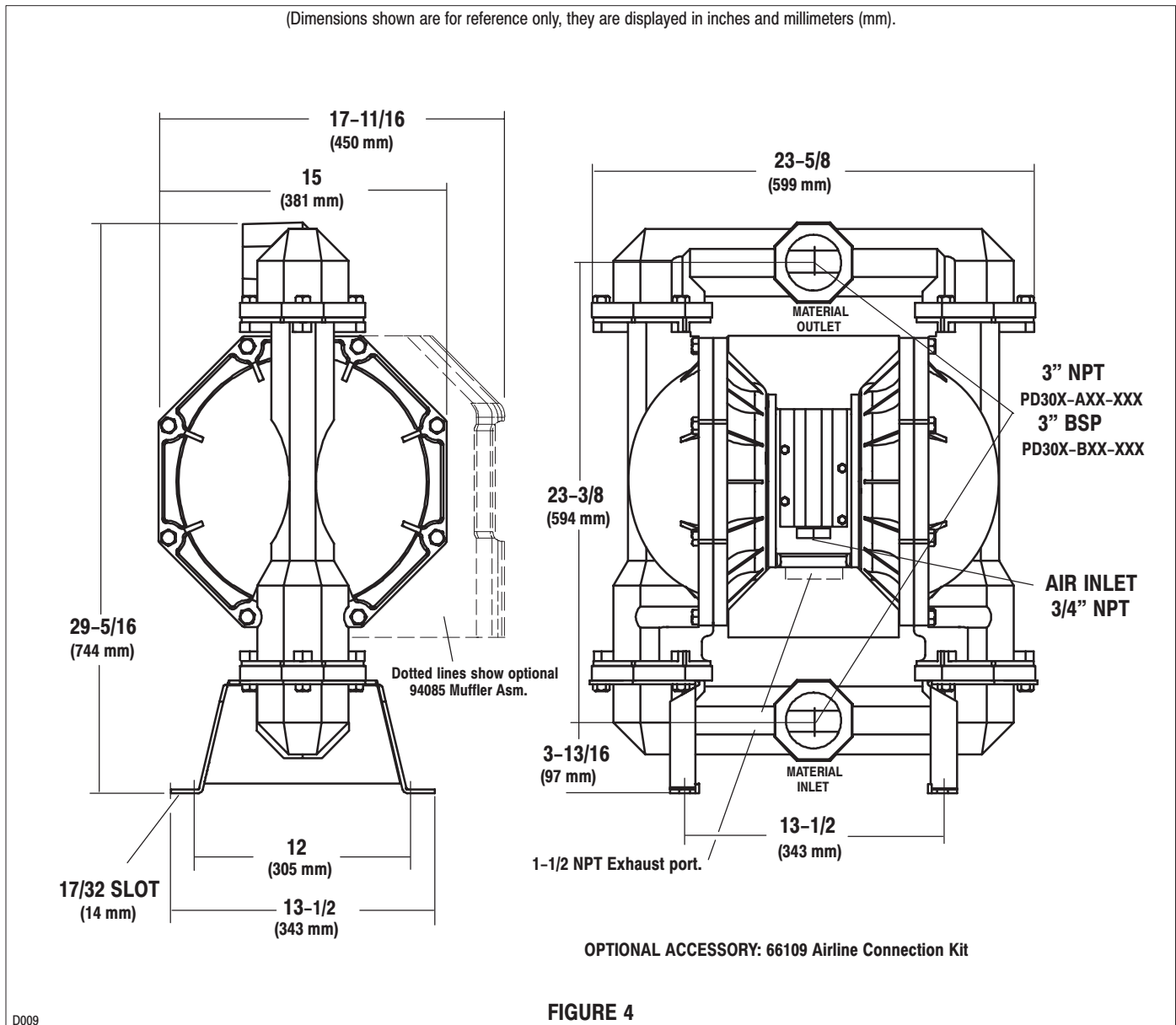

FIGURE 4

D009