

OPERATION MANUAL UNIVERSAL BINARY SENSOR FGBS-321-EN-A-v1.00

The Universal Binary Sensor is a wireless module that makes it possible to improve the functionality of any sensor with a binary output by allowing it to communicate with the wireless network Z-WAVE and the FIBARO building intelligence system. Moreover, the module allows for wireless communication between the system and the DS18B20 temperature sensors. The device can service up to two binary sensors and up to four DS18B20 temperature sensors. The Sensor was designed for installation in the housing of a sensor or another device, the functionality of which we wish to improve.

The Universal Binary Sensor may be used whenever wireless collection of data from sensors is required. Once additional safety housing has been installed, the Sensor can also be used in areas with high humidity and high temperature. The Sensor's main function is the integration of the wireless FIBARO system with the existing wire-based and wireless alarm and measurement systems. As an element of the safety system the device is transparent for parametric alarm lines.

Technical data

Supply voltage:	9-30V DC ±10%
Input:	2 potential-free inputs, 1 digital input 1-wire
Output:	2 potential-free outputs
Maximum current carrying capacity of outputs:	150mA
Maximum voltage at output contacts:	36V DC / 24V AC ±5%
Operating temperature:	0 - 40 °C
Number of servicing temperature sensors:	4
Measurement range:	-55°C - +126°C
Radio protocol:	Z-Wave
Radio frequency:	868,4 MHz for EU; 908,4 MHz for US; 921,4 MHz for AUS/NZ/BRA
Range:	up to 30 m in buildings (depending on the construction materials) up to 50m in the field
Dimensions (L x W x H):	27,3 x 14,5 x 12 mm

Technical information

- Controlled with FIBARO system devices or any Z-Wave controller
- Microprocessor-based control
- Compatible with regular and parametric alarm lines (can be connected to 2 alarm detectors)
- Compatible with binary sensors (can be connected to 2 binary outputs)
- Compatible with DS18B20 temperature sensors (can be connected to four DS18B20 temperature sensors)
- In order to connect the DS18B20 sensors it is recommended to use conductors made from a single wire with a length of up to 30 meters



DANGER
The Sensor is powered with secure voltage; nevertheless, the user should be extra careful or should commission the installation to a qualified person.

Hint
The outputs of the device should not be loaded with a current value exceeding 150mA

Hint
Connections should be made specifically according to the diagrams presented in this manual. Incorrect connection may lead to hazards.

I GENERAL INFORMATION ON THE FIBARO SYSTEM

FIBARO is a system that does not require any additional conductors; it is based on the Z-Wave technology. FIBARO offers a wide array of advantages in comparison to other, similar systems. In general, radio-based systems establish a direct connection between the receiver and the transmitter. The radio signal is attenuated by every obstacle along its path (in the household e.g. walls, furniture, etc.). In the worst case the radio system ceases to function. The advantage of the FIBARO system is the fact that the devices act not only as a signal receiver and transmitter, but also as a signal "repeater". If a direct radio link between the transmitter and the receiver cannot be established, the connection will be carried out with the use of other devices participating in communication.

FIBARO is a bidirectional wireless system. This means that the signal is not only sent to the receivers, but also the receivers send feedback confirming the reception of the signal. This also confirms the condition of receivers, which allows us to check whether or not a device has actually been switched on. The safety of transmission of the FIBARO system is comparable with a wire-linked bus system.

FIBARO operates in the free band for data transmission. The frequency depends on radio regulations in individual country. Each FIBARO network has its own unique network identification number (home ID), which is why it is possible to co-operate two or more independent systems in a single building without any interference.

Although the Z-Wave technology is fairly new, it has already been accepted as an official standard, just like Wi-Fi. Numerous manufacturers from various fields offer solutions based on Z-Wave technology, which are compatible with one another. This makes the system fit for the future and allows for further development. For more information go to www.fibaro.com.

FIBARO establishes a dynamic network structure. From the moment of start-up, the location data of respective devices of the FIBARO system is updated automatically, in real time, by confirming their condition in the working „mesh“ network.

II. Sensor Installation

- Before the installation make sure to switch off the alarm system, or any other system to which the device is to be connected.
- Connect the Fibaro Sensor according to the diagram.
- Place the Fibaro Sensor in the sensor housing.
- Arrange the antenna (instructions can be found below the diagrams).

EXPLANATION OF CONDUCTOR MARKINGS:

P – (POWER) – power supply conductor, red
 GND – (GROUND) – ground conductor, blue
 OUT1 – output no. 1 assigned to input IN1
 OUT2 – output no. 2 assigned to input IN2
 TP – (TEMP_POWER) – power supply conductor of the DS18B20 temperature sensor, brown (3.3V)
 TD – (TEMP_DATA) – signal conductor of the DS18B20 temperature sensor, white
 ANT – antenna, black
 OUT1 – output no. 1 assigned to input IN1
 OUT2 – output no. 2 assigned to input IN2
 B – maintenance button (used to add devices to and remove devices from the system)

ANTENNA ARRANGEMENT INSTRUCTIONS:

Hint
Lay down the antenna as far as possible from metal elements (connection conductors, ring brackets etc.), in order to prevent any interference of the radio signal.

Hint
Metal surfaces in close vicinity (e.g. metal embedded boxes, metal door trims) may impair the reception capability!

Hint
You should not cut off or shorten the antenna. Its length is suited ideally to the band at which the system functions.

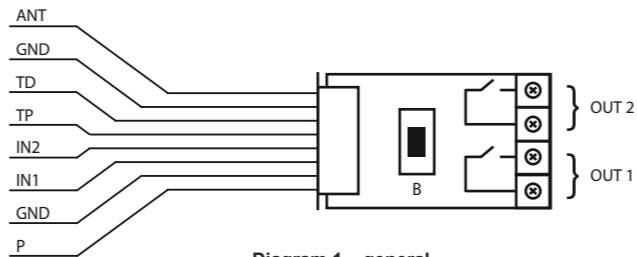

Diagram 1 – general

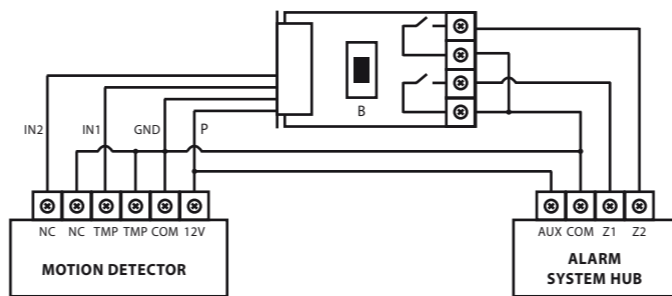

Diagram 2 – connection to a regular alarm line

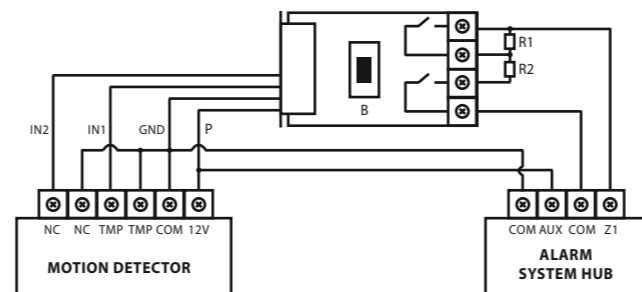

Diagram 3 – connection to a parametric alarm line

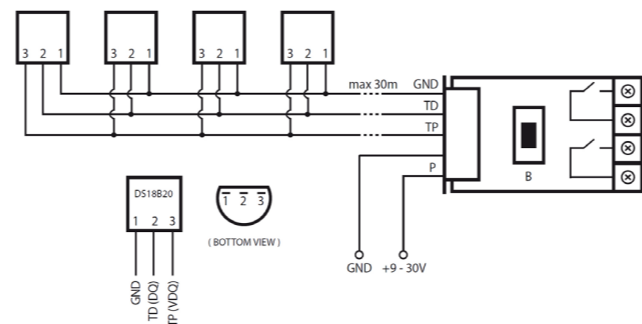

Diagram 4 – connection to DS18B20 sensors

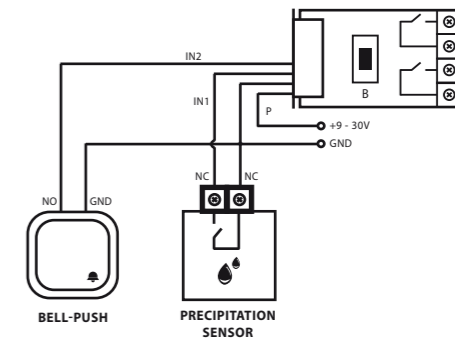

Diagram 5 – example connection to a precipitation sensor

Hint
Do not remove the protective layer surrounding the module. Make sure that no metal parts of other devices or conductors come into close contact with the installed Sensor.

Hint
Condition of outputs OUT1 and OUT2 is dependent only on the condition of corresponding inputs, irrespective of parameter settings or addition of device to the Z-wave network.

Hint
It should be noted that only the B button starts the device's programming process (Include/Exclude).

Hint
Do not connect other sensors than DS18B20 to the 1-wire line (terminals TP and TD).

Hint
Every time when any changes are made to the configuration of TP and TD lines (1-wire), e.g. when DS18B20 sensor(s) is (are) included/excluded, it is necessary to execute the procedure of exclusion and repeated inclusion of the sensor module to the central hub. It should be remembered that the system shall enter into the programming mode only once all the connected sensors have been detected (about 10 s).

Hint
It is prohibited to connect the TP and TD lines to devices that are not compatible with the 1-wire protocol. Unused lines should be left insulated.

INSTRUCTIONS FOR ARRANGEMENT OF THE DS18B20 SENSOR:

The DS18B20 sensor may easily be installed wherever very precise temperature measurements are required. Moreover, if proper protective measures are undertaken, the sensor may be used in humid environments or under water, it may be embedded in concrete or placed under the floor.

GLOSSARY OF TERMS:

- INCLUSION** – the device sends out a Node Info frame, which makes it possible to add it to the Fibaro system (Home Center)
- EXCLUSION** – removal of device from the Fibaro system
- ASSOCIATION** – controlling other devices of the Fibaro system
- MultiChannel Association** - controlling other multi-channel devices of the Fibaro system

III Fibaro Sensor start-up

1. Installation of the Universal Binary Sensor Module

STEP 1
Connect the device according to the electrical diagram shown in figure 1. Engage the supply voltage.
[Inclusion / Exclusion] of the Fibaro Sensor [to / from] the Z-Wave network

STEP 2
The Fibaro Module must be in range of the Home Center 2 controller, because the procedure of inclusion to the Fibaro system requires direct communication with the controller.

STEP 3
Recognition of B button, which allows for proper inclusion of device.

STEP 4
Setting the Home Center 2 controller to the inclusion or exclusion mode (see: Home Center 2 controller instructions).

STEP 5
The Fibaro Sensor is added to the network by quickly pressing the B button three times (the button is located in the center of the device).

STEP 6
Correct inclusion of the device to the network will be signaled by Home Center 2 (see: Home Center 2 central hub operation instructions).

2. Resetting the Fibaro Sensor

There are two procedures you can follow in order to reset the Fibaro Sensor.

Method I
Resetting in the course of the procedure of excluding the Fibaro Module from an existing Z-wave network. Devices may be excluded with the use of a controller, which offers the option to exclude devices from or include devices to the Z-wave network (see: controller instructions).

Method II
Resetting by cutting off the power supply and re-connecting the power supply while holding down the B button – after 10 seconds, after another cut-off and re-connection of power supply the settings of the device will be reset.

3. Controlling the Fibaro Sensor with the Home Center 2 controller

The FGBS221 Sensor is a multi-channel device. This means that it is equipped with two independent input circuits and a 1-wire bus allowing it to be connected to four DS18B20 temperature sensors. As a result, each device connected to the Sensor is represented by an independent icon in the system.

After the Fibaro Sensor has been added to the network, it shall be represented by appropriate icons in the Home Center 2 controller, depending on the number of connected devices (3 – 7 icons).

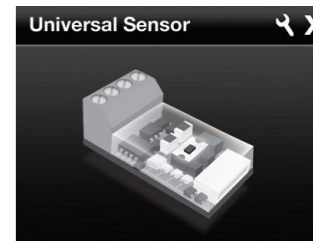

Fig. 1 - Fibaro Sensor icon in the Home Center controller

In the event of including the Sensor without any sensors connected (or with sensors connected only to IN1 and IN2), the device will be represented by three icons. If DS18B20 sensors are also connected, the devices will be represented by additional temperature icons.

