

Automatic Self-leveling Rotary Laser RL250S

User Manual



Maintenance and Safety

- While the instrument is operating, be careful not to expose your eyes to the laser beam. Direct exposure to a laser beam for a long time may be hazardous to your eyes. The laser beam is equivalent to a class II (and **class 3R** for **HV Green Beam**).
- Operate this laser so that the laser beam plane avoids impact on the eyes of vehicle drivers or pedestrians.
- Do not try to dismantle the instrument. Have it repaired by your dealer or supplier. Dismantling yourself may worsen the problem or void your warranty.
- When attaching the instrument to a tripod, make sure the instrument is securely fixed. The tripod leg clamps should be securely fastened. If not securely fastened or tightened, the main unit could fall off or the tripod could fall over.
- The laser should not be stored or used in extreme temperature or during rapid temperature change. The laser may not function properly if used out of the ambient temperature range.
- Store inside the carry case and place in a dry area not subject to vibration, dust or high moisture.
- If the storage temperature and ambient temperature for usage vary significantly, leave the laser in its case until it can adjust to the ambient temperature.
- The laser should be transported or carried carefully to avoid impact or vibration.
- The laser should be stored in the carry case and packed with cushioning material. Always handle the laser with care.

1. What is included with your RL250S



Your RL250S includes the following parts:-

Main Instrument

Detector and Bracket

Remote Control

Charger

Target

Glasses

Hard Case with Foam Insert

Extra Alkaline Battery Pack c/w 4xAA Alkaline batteries .

Wall Mount Bracket

Please contact your supplier if any of the above parts are missing.

2. Find your way around the RL250S



2.1 Control

Panel



Right Spin

Left Spin

Manual/Auto

Direction Scan

Head Speed

Arrow Area

H.I Alert

Switch ON/OFF

2.2 Utilities of Panel

- (1) Switch ON/OFF: Powers the laser up or down.
- (2) Power indicator: When the light is on, the instrument is on.
- (3) Manual/Automatic: The laser will initially enter into self leveling mode after be powered on. Press “Manual/Auto” for once, the device enter into manual mode, in the meanwhile the slope of Y-axis can be adjusted by up and down arrows on keypad panel, while press “Manual/Auto” again, the slope on X-axis can be set up by two arrows on panel. In these period ,the other functions such as scanning, left spin or right spin are also available but without accuracy. When press “Manual/Auto” the third time, the laser will get back to Auto-level mode and will self leveling again.
- (4) Manual/Auto indicator: When Y indicator lights, the slope of Y axis can be adjust, when X indicator turns on, the X-axis slope can be adjusted.
- (5) Head speed: To change the speed of the rotating beam, press the [Hare/Tortoise Button]. Speeds of 0rpm, 60rpm 300rpm & 600rpm(Max.) can be obtained.
- (6) Tilt/H.I alert: Enabling this mode warns the user if the laser level has been jolted.

- (7) Tilt indicator: When the light is blinking slowly, the laser is in H.I alert mode. When the light is blinking quickly, the laser level will not level as it has been jolted.
- (8) Directional scanning: Circling knob. Angle of scanning includes 5 levels: 0-10°-45° -90°-180° **H1 is without this function.**
- (9) Left-spinning: Allows the laser beam to step/move counter-clockwise, only when the unit is in 0 RPM or scan mode. **H1 is without this function.**
- (10) Right-spinning: Allows the laser beam to step/move clockwise, only when the unit is in 0 RPM or scan mode. **H1 is without this function.**
- (11) Arrows: Adjust the slope for both axis by working together with Manual/Automatic button.

3. Directions:

3.1 Battery Installation

Rechargeable and alkaline battery packs are suitable for use to power this laser. To install:

1. Un-screw the bolt at the bottom of base part. Take off the battery pack. The laser is officially c/w a Ni-Mh battery pack.
2. Either to put the alkaline battery pack into the port or Ni-Mh battery pack according to the right electrode.
3. Re-screw the bolt at the bottom of base part.
4. H1 comes without Ni-Mh battery pack.

3.2 Instrument Placement

3.2.1 Horizontal scanning

Place the instrument on a tripod or stable flat surface, or hang it on a wall. Set the unit upright, and keep the slope of the instrument within the range of -5 to +5 self-leveling range.

3.2.2 Vertical scanning

Place the instrument on the flat surface, and keep the slope of instrument within the range from -5° to +5, **H1 is without this function.**

3.3 Operations

3.3.1 Power

Press the ON/OFF key to switch the laser on. If the power indicator light blinks, the voltage of the batteries is low and batteries need to be replaced or recharged.

3.3.2 Leveling

When you turn the laser on, it will automatically level. The leveling process is indicated by a blinking laser beam. After the laser has automatically leveled, the laser rotating head will rotate at the speed of 600 RPM.

If the instrument is placed improperly, or the slope of instrument exceeds the range of -5 to +5, the mode indicator and the laser beam will blink at the same time.

Note: The instrument will shut down automatically if the unit exceeds the self-leveling system range for more than 5 minutes.

3.3.3 Spinning

(1) Continuous spinning

Press the Key “Rotational speed adjustment” to control the spinning speed of the laser module. If press the key repeatedly, the spinning speed of the laser module will continuously change as follows: 0-60-300-600-0 r.p.m.

(2) Stepping spinning

Press the speed key until it is at 0 r.p.m, the laser module will stop spinning. Press the Key Right-Spinning, the laser module will move clockwise. Press the Key Left-Spinning, the laser module will move counter-clockwise.

3.3.4 Directional scanning

(1) Press the Speed key until it is at 0 r.p.m, the laser module will stop spinning. Press the Key Directional scanning; the laser module will scan directionally. If press the key repeatedly, the angle of scanning of laser module will continuously change as follows: 0° -10° 45° -90° 180° -0° .



(2) Press the Key Left-spinning or the Key Right-spinning to change the direction of scanning.

3.3.5 Slope Adjustment

When the instrument is set upright for horizontal rotation, the slope of the X-axis and Y-axis can be adjusted by using manual mode. To select manual mode, Press the Key Manual/Automatic, the instrument will first enter into the mode of manual adjustment..



(1) Slope of X-axis

a. Aim the X1-beam to the direction of the slope required.

b. Press the arrow  or  to move the laser beam up or down until the beam/line get to its required position.

(2) Slope of Y-axis

a. Aim the Y1-beam to the direction of the slope required.

b. Press the arrow  to  move the laser beam up or down until the beam/line get to its required position.

(3) Quit slope adjustment mode

Press Manual/Automatic key again. After mode goes off, the instrument will exit the

slope adjustment mode/manual mode and will start to self-level again.



3.3.6 Vertical Lines



Once the instrument is in the position shown above, The instrument will Auto level and start spinning giving a Vertical beam.

4. Power



Insert the charger into the mains and the charging socket into the instrument or the battery pack. Turn on the power. The charger will show one of 3 modes.

- Red flashing light - Battery not charging
- Red light - Battery on Charge
- Green light - Battery charged

If the red light shows check the connection.

If the light is flashing please wait for charging to complete.

Once the green light shows the instrument is fully charged- charging normally takes 7 hours to give 20 hours of use.

Either Ni-Mh battery pack (the standard one) or Alkaline battery pack is available to work as power supply.

Notices:

- (1) Using the standard rechargeable batteries of the instrument, recharging will be finished within 8 hours.(4x5000mAh Ni-Mh batteries)**
- (2) Power required for the charger: Frequency: 50-60HZ; Voltage: 85-265V.**
- (3) Charging and using of the instrument can progress simultaneously.**
- (4) If keeping the instrument in storage (or Leave the instrument unused for a long time), the batteries (dry battery or rechargeable battery) needs to be taken out.**
- (5) Brand-new rechargeable batteries or long-time unused rechargeable batteries need to be recharged and discharged three times to attain the capacity required.**

5. Remote

The remote control of the instrument adopts the infrared technique.

Aim the aperture of infrared ray to the instrument (as depicted below) to bring remote controlling into function (Available distance: indoor: 30M; outdoor: 20M). The keypad panel includes 9 keys; the indicator on the RC will wink to show the operating signal has been sent out once pressing any key.



Functions fulfilled by the remote as follows:

- (1) Spinning: Operating method referring to 3.3.3
- (2) Directional scanning: Operating method referring to 3.3.4
- (3) Slope adjustment: Operating method referring to 3.3.5

6. Detector

The detector will pick up a spinning beam when it crosses the electronic sensor window.

The detector has 3 buttons:

- a) On/off button
- b) A Sound button with 3 settings – off – low – high
- c) A sensitivity button. This will either give a narrow or a broader range of detection.

When the detector is too high a slower beep will be emitted, when too low, a fast beep will be emitted, when same level as beam a continuous pitch will sound- at this point the centre of the detector is at the same alignment as the beam.

To get accurate results use the spirit bubble to keep the detector level.

The detector is powered by a standard 9v battery.



7. Accuracy Checking

Follow these instructions for checking axis accuracy.

7.1 Horizontal-surface Checking

1. Place the instrument at the point of 50m in front of wall (or set a scale plate at the point of 50m away from the instrument), and then adjust the level of the base approximately to aim the X1 to the wall (or scale plate), as depicted below:

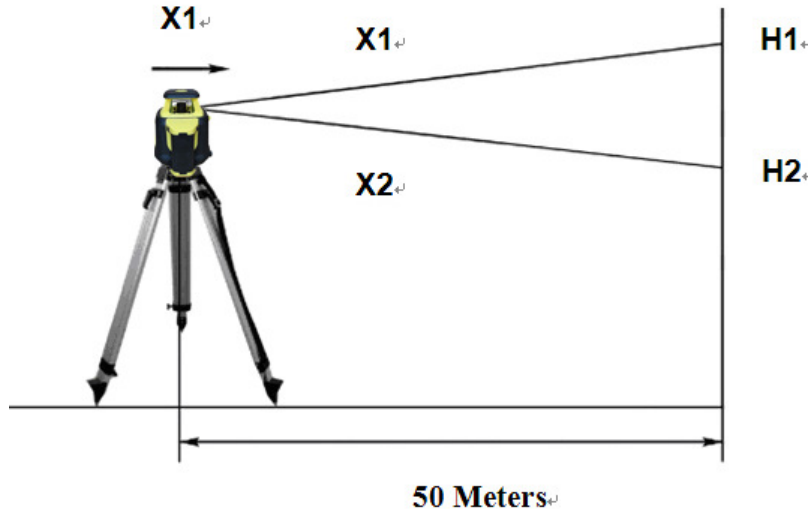

2. Allow the unit to level and begin rotating. Mark the beam position on the wall or scale plate as H1.
3. Loosen the screw of the tripod, and then turn the laser 180°. Allow the unit to level and rotate, mark the beam position on the wall or scale plate as H2.

The difference between the value of H1 and H2 should be less than 10 mm.

4. Repeat the same process to check your Y-axis beam. Again, the difference between the values of the two measurements should be less than 10 mm.
5. If the difference in either axis is more than 8mm, the laser should be sent to your authorized dealer for service/calibration.

7.2 Horizontal-line checking.

First lay down the instrument:

-Mount the instrument on tripod between A wall and B wall. Tripod near Wall A. Distance should follow the instructions on illustration. Switch the instrument on.

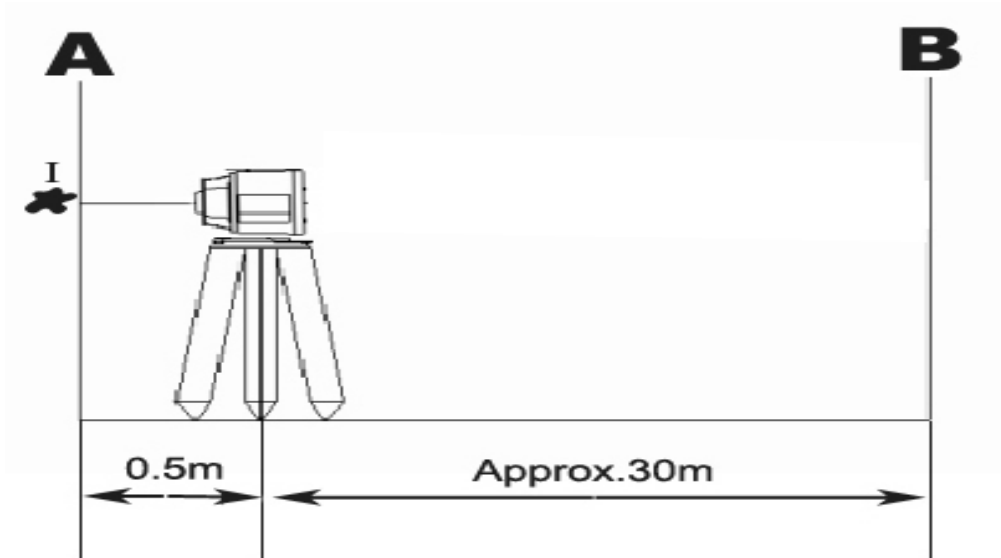

-After leveling, direct the laser beam onto the close wall A. Mark the centre point of the laser beam on the wall (Point I)

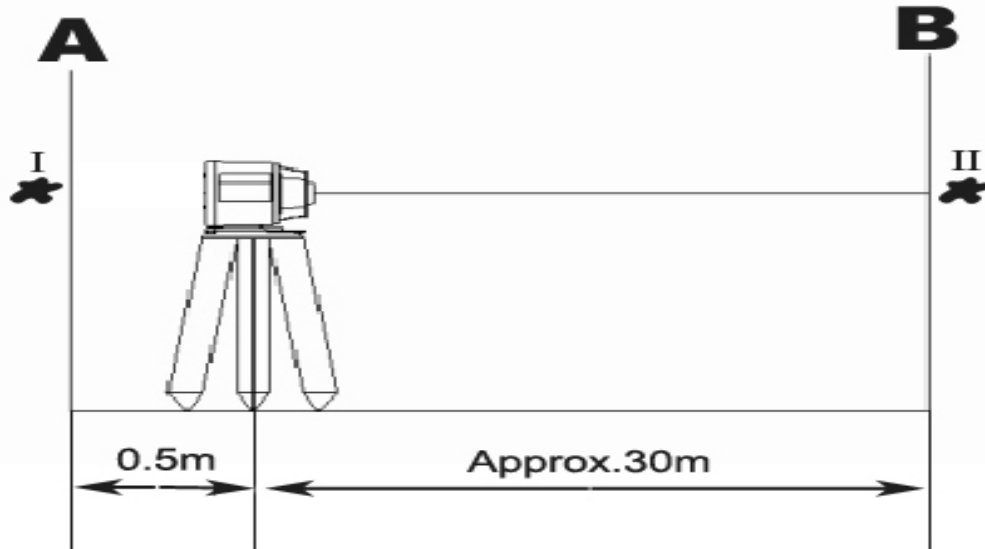

-Turn the instrument horizontally by 180° .(without changing the height).after leveling, direct the laser beam onto Wall B. Mark the centre point of the laser beam on the opposite wall B(Point II)

-Without turning the instrument. Position it close to wall B by moving the tripod. Switch on the instrument and let it leveling.

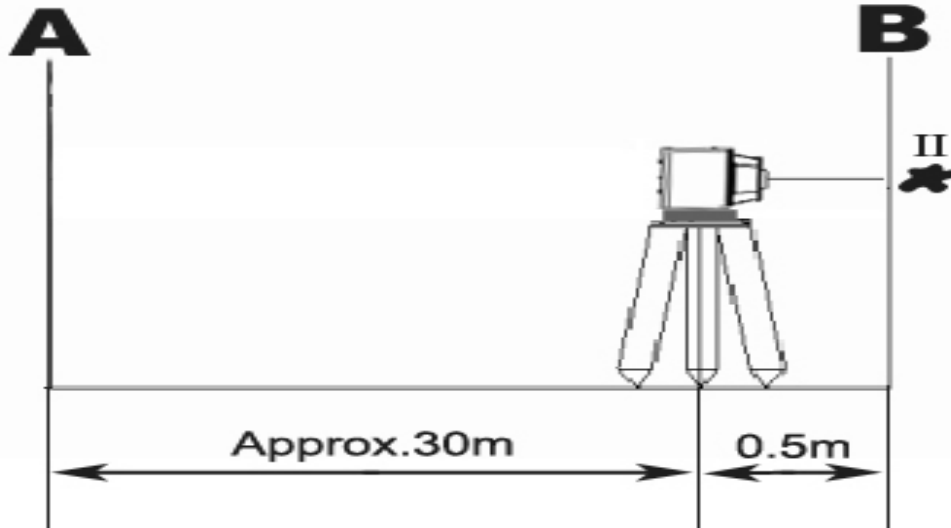

-After leveling, align the height of the instrument by using tripod or by underlaying, if necessary. In such a manner that the centre point of the laser beam is projected exactly located the previously marked point II on wall B.

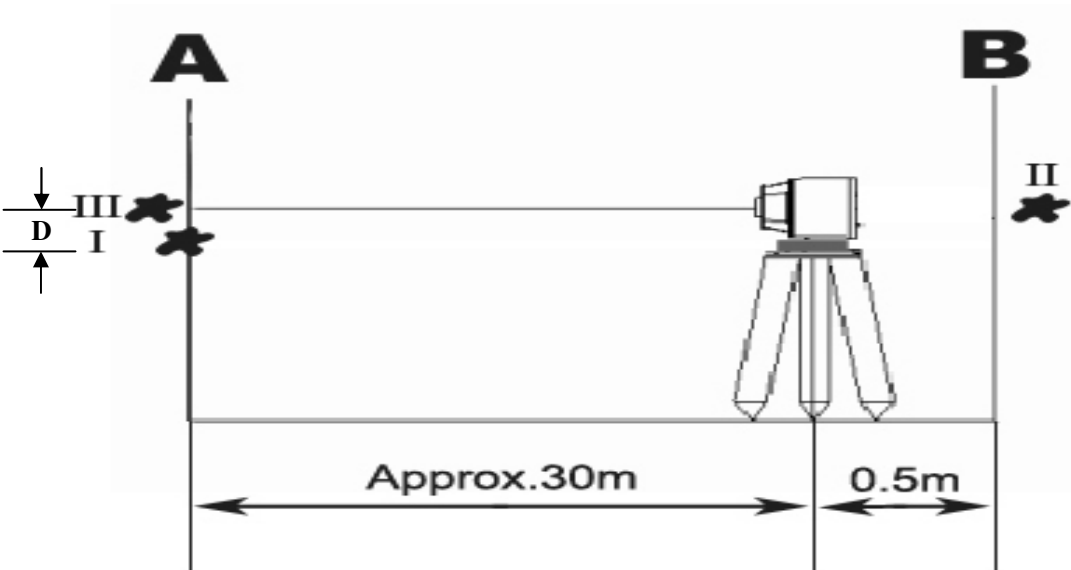

-Rotate the instrument by 180° without changing the height. Allow it to level in and mark the centre point of the laser beam on wall A(point III).Tare care that point III is as vertical as possible above or below point I.

-The difference D of both marked points I and III on wall A amounts to the actual deviation of the plumb up beam

D-value should be less than 4mm.

8. Specifications

Accuracy:	20 arc seconds(+/-1mm/10m)
Self leveling range:	±5°
Operation range(With detector)	500m with detector (Diameter)
Four head speeds:	0,60,300,600 R. P. M.
Four scan widths:	10°; 45°; 90°; 180°
Bright, visible beam:	Wavelength 635nm:HV Class II Wavelength 535nm:HV Green Class 3R
IR Remote control:	Available distance:20 m
Operation temperature:	-20°C ~ +50°C (-4 °F~+122 °F)
Power supply:	DC 4. 8-6V (4xsub-C NI-MH battery or 4xsub-C Alkaline battery)
Continuance working time:	Approx. 50hr.(Ni-MH) Approx. 40hr(Alkaline)
Waterproof and dustproof:	IP 55
Dimension:	160(L) X 160(W)X 185(H)mm
Weight:	2.7kg