M-Turbo™ Ultrasound System



User Guide

CE
0086

 SonoSite®

M-Turbo™ Ultrasound System

User Guide

SonoSite, Inc.

21919 30th Drive SE

Bothell, WA 98021

USA

T: 1-888-482-9449 or 1-425-951-1200

F: 1-425-951-1201

SonoSite Ltd

Alexander House

40A Wilbury Way

Hitchin

Herts SG4 0AP

UK

T: +44-1462-444800

F: +44-1462-444801

Caution: | Federal (United States) law restricts this device to sale by or on the order of a physician.

M-Turbo, SiteLink, SonoCalc, SonoHD, SonoMB, and SonoSite are registered trademarks or trademarks of SonoSite, Inc.

DICOM is the registered trademark of the National Electrical Manufacturers Association for its standards publications relating to digital communications of medical information.

Non-SonoSite product names may be trademarks or registered trademarks of their respective owners.

Protected by U.S. patents: 5722412, 5817024, 5893363, 6135961, 6364839, 6371918, 6383139, 6416475, 6471651, 6569101, 6648826, 6962566, 7169108, D456509, D538432. Patents pending.

P07662-01 11/2007

Copyright 2007 by SonoSite, Inc.

All rights reserved.

Contents

Introduction

Conventions, symbols, and terms	vii
Customer comments	vii

Chapter 1: Getting Started

About the system	1
About the system software	2
Transducers, accessories, and peripherals	2
Intended uses	2
Preparing the system	5
Installing or removing the battery	5
Using AC power and charging the battery	6
Turning the system on or off	6
Connecting transducers	7
Inserting and removing USB storage devices	7
System controls	9
Screen layout	12
General interaction	13
Touchpad and cursor	13
On-screen options	13
Annotation and text	14
Preparing transducers	16

Chapter 2: System Setup

A & B Key, Footswitch setup	17
Administration setup	18
Security settings	18
User setup	19
Exporting or importing user accounts	20
Exporting and clearing the Event log	20
Logging in as user	21
Choosing a secure password	21
Annotations setup	22
Audio, Battery setup	23
Cardiac Calculations setup	23
Connectivity setup	24
Date and Time setup	25
Display Information setup	25
IMT Calculations setup	25
Network Status setup	26
OB Calculations setup	26

OB Custom Measurements setup	27
OB Custom Tables setup	28
Presets setup	29
System Information setup	30
USB Devices setup	30
Restoring default settings	31

Chapter 3: Imaging

Imaging modes	33
Adjusting depth and gain	33
Freezing, viewing frames, and zooming	33
Changing the exam type	34
2D imaging	34
M Mode imaging	36
CPD and color Doppler imaging	37
PW and CW Doppler imaging	39
Imaging modes and exams available by transducer	42
Annotations	43
Patient information form	45
Saving images and clips	48
Patient list	50
ECG Monitoring	52

Chapter 4: Measurements and Calculations

Measurements	55
Working with calipers	55
2D measurements	56
M Mode measurements	58
Doppler measurements	59
General calculations	61
Calculations menu	61
Performing and saving measurements in calculations	62
Viewing, repeating, and deleting saved measurements in calculations	62
Percent reduction calculations	63
Volume calculations	65
Volume flow calculations	66
Specialized calculations	68
Cardiac calculations	68
Gynecology (Gyn) calculations	79
IMT calculations	80
OB calculations	83
Small Parts calculations	89
Vascular calculations	90
Patient report	92
Vascular and cardiac reports	92

OB reports	92
Sending reports and viewing EMED worksheets	94

Chapter 5: Troubleshooting and Maintenance

Troubleshooting	95
Software licensing	96
Maintenance	97
Cleaning and disinfecting the ultrasound system	98
Cleaning and disinfecting transducers	99
Cleaning and disinfecting transducer cables	101
Cleaning and disinfecting the battery	102
Cleaning the footswitch	102
Cleaning and disinfecting ECG cables	102

Chapter 6: Safety

Ergonomic safety	111
Position the system	112
Position yourself	112
Take breaks, exercise, and vary activities	113
Electrical safety classification	113
Electrical safety	113
Equipment safety	116
Battery safety	116
Biological safety	117
Electromagnetic compatibility	118
Manufacturer's declaration	119
ALARA principle	122
Applying ALARA	123
Direct controls	123
Indirect controls	124
Receiver controls	124
Acoustic artifacts	124
Guidelines for reducing MI and TI	124
Output display	126
Mechanical and thermal indices output display accuracy	127
Factors that contribute to display uncertainty	127
Related guidance documents	127
Transducer surface temperature rise	128
Acoustic output measurement	129
<i>In Situ</i> , derated, and water value intensities	129
Tissue models and equipment survey	130
Acoustic output tables	131
Terms used in the acoustic output tables	148
Acoustic measurement precision and uncertainty	149
Labeling symbols	150

Chapter 7: References

Measurement accuracy	155
Sources of measurement errors	157
Measurement publications and terminology	157
Cardiac references	157
Obstetrical references	164
Gestational age tables	165
Growth analysis tables	167
Ratio calculations	169
General references	169

Chapter 8: Specifications

Dimensions	173
Supported transducers	173
Imaging modes	173
Images and clips storage	174
Accessories	174
Peripherals	174
Temperature and humidity limits	175
Operating limits	175
Shipping and storage limits	175
Electrical	175
Battery	175
Electromechanical safety standards	176
EMC standards classification	176
Airborne equipment standards	176
DICOM standard	176
HIPAA standard	177

Glossary

Terms	179
Abbreviations	181

Index	191
--------------------	-----

Introduction

This *M-Turbo Ultrasound System User Guide* provides information on preparing and using the M-Turbo™ ultrasound system and on cleaning and disinfecting the system and transducers. It also provides references for calculations, system specifications, and safety and acoustic output information.

The user guide is for a reader familiar with ultrasound techniques. It does not provide training in sonography or clinical practices. Before using the system, you must have ultrasound training.

See the applicable SonoSite accessory user guide for information on using accessories and peripherals. See the manufacturer's instructions for specific information about peripherals.

Conventions, symbols, and terms

The user guide follows these conventions:

- A **WARNING** describes precautions necessary to prevent injury or loss of life.
- A **Caution** describes precautions necessary to protect the products.
- Numbered steps must be performed in a specific order.
- Bulleted lists present information in list format but do not imply a sequence.

Symbols and terms used on the system and transducer are explained in [Chapter 2](#), [Chapter 5](#), [Chapter 6](#), and [Glossary](#).

Customer comments

Questions and comments are encouraged. SonoSite is interested in your feedback regarding the system and the user guide. Please call SonoSite at 888-482-9449 in the US. Outside the US, call the nearest SonoSite representative. You can also e-mail SonoSite at comments@sonosite.com.

For technical support, please contact SonoSite as follows:

SonoSite Technical Support

Phone (US or Canada): 877-657-8118

Phone (Outside US and Canada): 425-951-1330
Or call your local representative.

Fax: 425-951-6700

E-mail: service@sonosite.com

Web site: www.sonosite.com. Click Support & Service.

Europe Service Center: +44-(0)1462-444-800
e-mail: uk.service@sonosite.com

Chapter 1: Getting Started

About the system

The M-Turbo ultrasound system is a portable, software-controlled device using all-digital architecture. The system has multiple configurations and feature sets used to acquire and display high-resolution, real-time ultrasound images. Features available on your system depend on system configuration, transducer, and exam type.

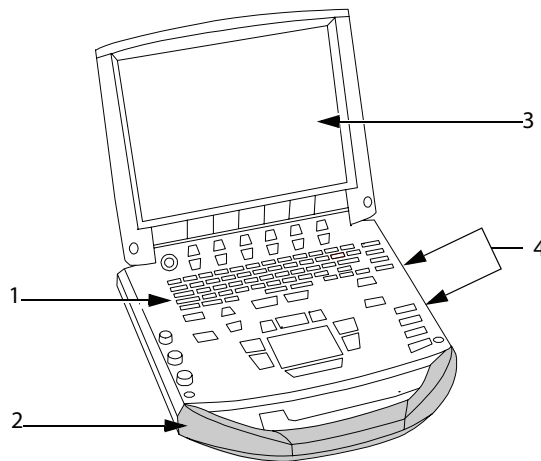

Figure 1 System Front Features:

(1) Control panel, (2) Handle, (3) Display, (4) USB ports for storage, updates, importing, and exporting

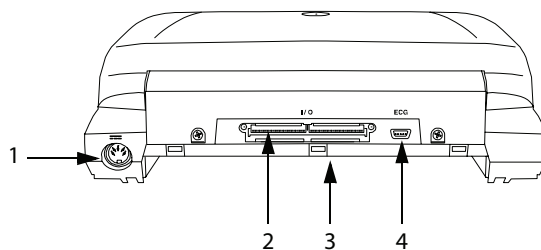

Figure 2 System Back Connectors:

(1) DC input connector, (2) I/O connector, (3) Battery, and (4) ECG connector

To use the ultrasound system

- 1 Turn the system on. (For power switch location, see “System controls” on page 9.)
- 2 Attach a transducer.
- 3 Press the PATIENT key, and complete the patient information form.
- 4 Press an imaging mode key:
 - 2D
 - M MODE
 - COLOR
 - DOPPLER

About the system software

The ultrasound system contains software that controls its operation. A license key is required to activate the software. See “Software licensing” on page 96.

On occasion, a software upgrade may be required. SonoSite provides a USB device containing the software. One USB device can be used to upgrade multiple systems.

Transducers, accessories, and peripherals

The ultrasound system may include transducers, accessories and peripherals. Peripherals include medical grade (conforming to EN60601-1 requirements) and non-medical grade (commercial) products. Manufacturer’s instructions accompany each peripheral.

See [Chapter 8, “Specifications,”](#) for a complete list of compatible transducers, accessories, and peripherals.

Intended uses

The intended uses for each exam type are as follows. For the intended transducer for each exam type, see “Imaging modes and exams available by transducer” on page 42.

Abdominal Imaging Applications This system transmits ultrasound energy into the abdomen of patients using 2D, M Mode, color Doppler (Color), color power Doppler (CPD), Tissue Harmonic Imaging (THI), and pulsed wave (PW) Doppler to obtain ultrasound images. The liver, kidneys, pancreas, spleen, gallbladder, bile ducts, transplanted organs, abdominal vessels, and surrounding anatomical structures can be assessed for the presence or absence of pathology transabdominally.

Cardiac Imaging Applications This system transmits ultrasound energy into the thorax of patients using 2D, M Mode, color Doppler (Color), Tissue Harmonic Imaging (THI), pulsed wave (PW) Doppler, pulsed wave tissue Doppler (TDI PW), and continuous wave (CW)

Doppler to obtain ultrasound images. The heart, cardiac valves, great vessels, surrounding anatomical structures, overall cardiac performance, and heart size can be assessed for the presence or absence of pathology.

The patient's electrocardiogram (ECG) may be obtained and is used for timing of diastolic and systolic function.

WARNING: The ECG is not used to diagnose cardiac arrhythmias and is not designed for long term cardiac rhythm monitoring.

Gynecology and Infertility Imaging Applications This system transmits ultrasound energy in the pelvis and lower abdomen using 2D, M Mode, color power Doppler (CPD), color Doppler (Color), Tissue Harmonic Imaging (THI), and pulsed wave (PW) Doppler to obtain ultrasound images. The uterus, ovaries, adnexa, and surrounding anatomical structures can be assessed for the presence or absence of pathology transabdominally or transvaginally.

Interventional Imaging Applications This system transmits ultrasound energy into the various parts of the body using 2D, color Doppler (Color), color power Doppler (CPD), Tissue Harmonic Imaging (THI), and pulsed wave (PW) Doppler to obtain ultrasound images that provide guidance during interventional procedures. This system can be used to provide ultrasound guidance for biopsy and drainage procedures, vascular line placement, peripheral nerve blocks, spinal nerve blocks and taps, ova harvesting, amniocentesis and other obstetrical procedures, and provide assistance during abdominal, breast, and neurological surgery.

Obstetrical Imaging Applications This system transmits ultrasound energy into the pelvis of pregnant women using 2D, M Mode, color Doppler (Color), color power Doppler (CPD), Tissue Harmonic Imaging (THI), and pulsed wave (PW) Doppler to obtain ultrasound images. The fetal anatomy, viability, estimated fetal weight, gestational age, amniotic fluid, and surrounding anatomical structures can be assessed for the presence or absence of pathology transabdominally or transvaginally. CPD and color Doppler (Color) imaging is intended for high-risk pregnant women. High-risk pregnancy indications include, but are not limited to, multiple pregnancy, fetal hydrops, placental abnormalities, as well as maternal hypertension, diabetes, and lupus.

WARNING: To prevent injury or misdiagnosis do not use this system for Percutaneous Umbilical Blood Sampling (PUBS) or *in vitro* Fertilization (IVF) The system has not been validated to be proven effective for these two uses.

CPD or Color images can be used as an adjunctive method, not as a screening tool, for the detection of structural anomalies of the fetal heart and as an adjunctive method, not as a screening tool for the diagnosis of Intrauterine Growth Retardation (IUGR).

Pediatric Imaging Applications This system transmits ultrasound energy into the pediatric patients using 2D, M Mode, color Doppler (Color), color power Doppler (CPD), pulsed wave (PW) Doppler, pulsed wave tissue Doppler (TDI PW), and continuous wave (CW) Doppler to

obtain ultrasound images. The pediatric abdominal, pelvic and cardiac anatomy, pediatric hips, neonatal head, and surrounding anatomical structures can be assessed for the presence or absence of pathology.

Prostate Imaging Applications This system transmits ultrasound energy into the prostate of an adult male using 2D, M Mode, color power Doppler (CPD), color Doppler (Color), and pulsed wave (PW) Doppler to obtain ultrasound images. The prostate gland can be assessed for the presence or absence of pathology.

Superficial Imaging Applications This system transmits ultrasound energy into various parts of the body using 2D, M Mode, color Doppler (Color), color power Doppler (CPD), and pulsed wave (PW) Doppler to obtain ultrasound images. The breast, thyroid, testicle, lymph nodes, hernias, musculoskeletal structures, soft tissue structures, and surrounding anatomical structures can be assessed for the presence or absence of pathology. This system can be used to provide ultrasound guidance for biopsy and drainage procedures, vascular line placement, peripheral nerve blocks, and spinal nerve blocks and taps.

Vascular Imaging Applications This system transmits ultrasound energy into the various parts of the body using 2D, M Mode, color Doppler (Color), color power Doppler (CPD), and pulsed wave (PW) Doppler to obtain ultrasound images. The carotid arteries, deep veins, and arteries in the arms and legs, superficial veins in the arms and legs, great vessels in the abdomen, and various small vessels feeding organs can be assessed for the presence or absence of pathology.

Preparing the system

Installing or removing the battery

WARNING: To avoid injury to the operator and to prevent damage to the ultrasound system, inspect the battery for leaks prior to installing.

To avoid data loss and to conduct a safe system shutdown, always keep a battery in the system.

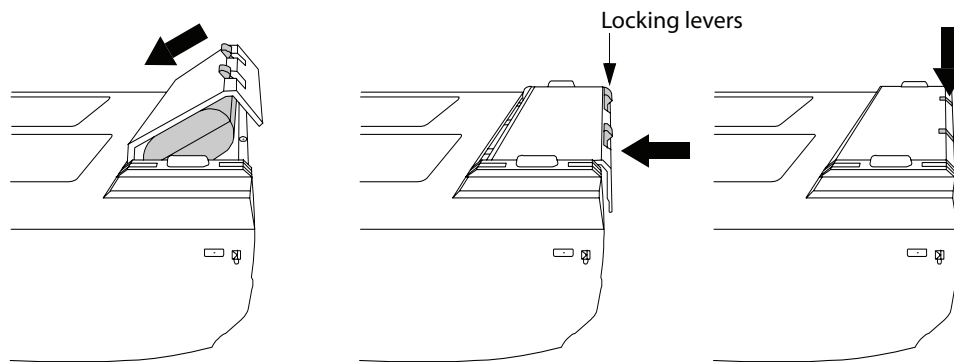

Figure 3 Install the Battery

To install the battery

- 1 Disconnect the power supply from the ultrasound system.
- 2 Remove the system from the mini-dock (if present) and turn it upside down.
- 3 Place the battery into the battery compartment, at a slight angle. See [Figure 3](#).
- 4 Slide the battery forward until it locks into place.
- 5 Push down on the two locking levers to secure the battery.

To remove the battery

- 1 Disconnect the power supply from the ultrasound system.
- 2 Remove the system from the mini-dock (if present) and turn it upside down.
- 3 Pull up the two locking levers.
- 4 Slide the battery back.
- 5 Lift the battery from the compartment.

Using AC power and charging the battery

The battery charges when the system is connected to the AC power supply. A fully discharged battery recharges in less than five hours.

The system can run on AC power and charge the battery if AC power is connected to the system directly, to a mini-dock, or to a docking system.

The system can run on battery power for up to two hours, depending on the imaging mode and the display brightness.

WARNING: The equipment shall be connected to a center-tapped single phase supply circuit when users in the United States connect the equipment to a 240V supply system.

Caution: Verify that the hospital supply voltage corresponds to the power supply voltage range. See [“Electrical”](#) on page 175.

To operate the system using AC power

- 1 Connect the DC power cable from the power supply to the connector on the system. See [Figure 2](#) on page 1.
- 2 Connect the AC power cord to the power supply and to a hospital-grade electrical outlet.

Turning the system on or off

Caution: Do not use the system if an error message appears on the display. Note the error code and turn off the system. Call SonoSite or your local representative.

To turn the system on or off

- ❖ Press the power switch. (See [“System controls”](#) on page 9.)

To wake up the system

To conserve battery life while the system is on, the system goes into sleep mode if the lid is closed or if the system is untouched for a preset time. To adjust the time for sleep delay, see [“Audio, Battery setup”](#) on page 23.

- ❖ Press a key, touch the touchpad, or open the lid.

Connecting transducers

- WARNING:** To avoid injury to the patient, do not place the connector on the patient. Operate the ultrasound system in a docking system or on a flat hard surface to allow air flow past the connector.
- Caution:** To avoid damaging the transducer connector, do not allow foreign material in the connector.

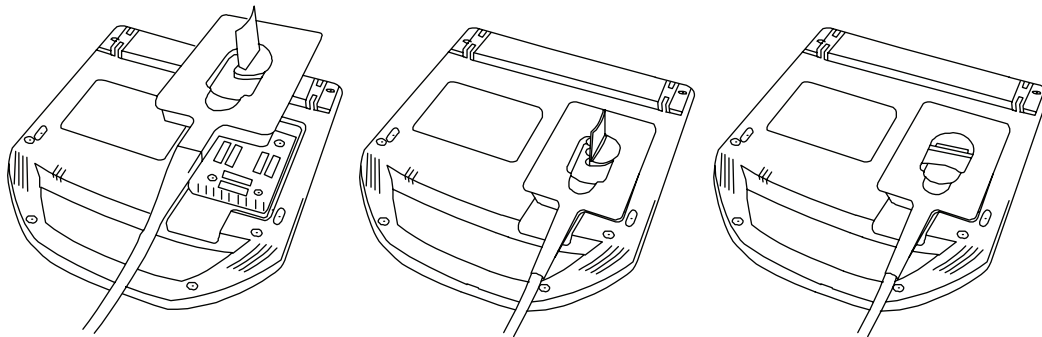

Figure 4 Connect the Transducer

To connect a transducer

- 1 Remove the system from the mini-dock (if present), and turn it upside down.
- 2 Pull the transducer latch up, and rotate it clockwise.
- 3 Align the transducer connector with the connector on the bottom of the system.
- 4 Insert the transducer connector into the system connector.
- 5 Turn the latch counterclockwise.
- 6 Press the latch down, securing the transducer connector to the system.

To remove a transducer

- 1 Pull the transducer latch up, and rotate it clockwise.
- 2 Pull the transducer connector away from the system.

Inserting and removing USB storage devices

Images and clips are saved to internal storage and are organized in a sortable patient list. You can archive the images and clips from the ultrasound system to a PC using a USB storage device or Ethernet connection. Although the images and clips cannot be viewed from a USB storage device on the ultrasound system, you can remove the device and view them on your PC.

There are two USB ports on the system, and one on the mini-dock. For additional USB ports, you can connect a USB hub into any USB port.

WARNING: To avoid damaging the USB storage device and losing patient data from it, observe the following:

- Do not remove the USB storage device or turn off the ultrasound system while the system is exporting.
- Do not bump or otherwise apply pressure to the USB storage device while it is in a USB port on the ultrasound system. The connector could break.

Caution: If the USB icon does not appear in the system status area on-screen, the USB storage device may be defective or password-protected. Turn the system off and replace the device.

To insert a USB storage device

❖ Insert the USB storage device into any USB port on the system or mini-dock. See [Figure 1](#) on page 1.

The USB storage device is ready when the USB icon appears.

To view information about the device, see [“USB Devices setup”](#) on page 30

To remove a USB storage device

Removing the USB storage device while the system is exporting to it may cause the exported files to be corrupted or incomplete.

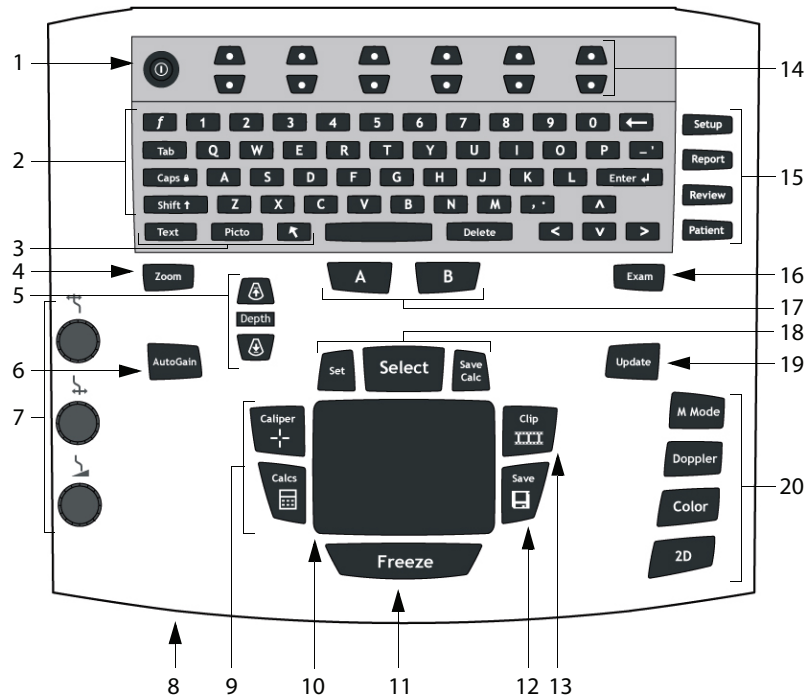

- 1** Wait five seconds after the USB animation stops.
- 2** Remove the USB storage device from the port.

System controls



Getting Started

1	Power switch	Turns system on and off.
2	Alphanumeric keys	Use to enter text and numbers.
3	Annotation keys	See <i>"Alphanumeric keyboard"</i> on page 14.
4	ZOOM	Magnifies the image 100%.
5	DEPTH UP, DEPTH DOWN	Decreases and increases imaging depth.
6	AUTO GAIN	Adjusts gain automatically.

7	Gain	
	 Near	Adjusts the gain applied to the near field of the image.
	 Far	Adjusts the gain applied to the far field of the image.
	 Gain/ Cine Buffer	In live imaging, adjusts the overall gain applied to the entire image. On a frozen image, moves the cine buffer.
8	AC power indicator	A steady light indicates that AC power is connected. A flashing light indicates that the system is asleep.
9	CALIPER CALCS	Displays calipers on-screen for measuring. Turns the calculations menu on and off.
10	Touchpad	Selects, adjusts, and moves items on-screen.
11	FREEZE	Stops live imaging and displays a frozen image.
12	SAVE	Saves an image to internal storage. If configured, also saves calculations to the report. See “Presets setup” on page 29.
13	CLIP	Saves a clip to internal storage.
14	Control keys	Control on-screen options.
15	Forms	
	SETUP	Displays the system settings.
	REPORT	Accesses the patient report and EMED worksheets.
	REVIEW	Accesses the patient list, saved images, and archiving functions.
	PATIENT	Accesses patient information.

16	EXAM	Opens exam menu.
17	Shortcut keys	Keys that you can program to perform common tasks.
18	SET	Sets a trace measurement.
	SELECT	Used with the touchpad to select items on-screen. Also switches between Color and Doppler options, calipers for measurement, pictograph-marker position and angle, frozen images in duplex and dual screens, and arrow position and orientation.
	SAVE CALC	Saves calculations and their measurements to the patient report.
19	UPDATE	Toggles between dual and duplex screens and imaging modes in M Mode and Doppler (for example, between D-line and Doppler spectral trace).
20	Imaging Modes	
	M MODE	Turns M Mode on, toggles between M-line and M Mode trace.
	DOPPLER	Turns Doppler on, toggles between D-line and Doppler trace.
	COLOR	Turns CPD/Color on and off.
	2D	Turns 2D on.

Screen layout

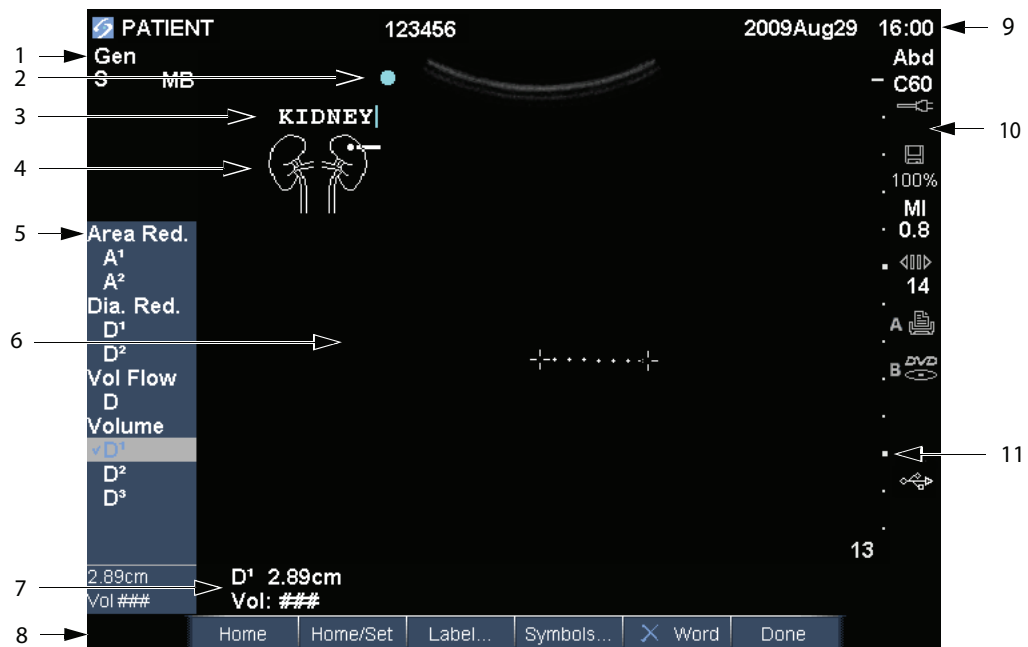

Figure 5 Screen Layout

1	Mode Data Area	Current imaging mode information (for example, Gen, Res, THI, and PW).
2	Orientation Marker	Provides indication for image orientation. In dual and duplex images, the orientation marker is green on the active screen.
3	Text	Text entered using keyboard.
4	Picto	Pictograph to indicate anatomy and transducer position. Displays pictograph options allowing anatomy and screen location selection.
5	Calculations Menu	Contains available measurements.
6	Image	Ultrasound image.
7	Measurement and Calculations Data Area	Current data on measurements and calculations.
8	On-screen Options	Options available in the current context.

9	Patient Header	Includes current patient name, patient ID number, institution, user, and date/time.
10	System Status	Information on system status (for example, exam type, transducer, AC connected, battery charging, and USB).
11	Depth Marker	Marks in .5 cm, 1 cm, and 5 cm increments depending on depth.

General interaction

Touchpad and cursor

Use the touchpad to adjust and move objects on-screen. The touchpad controls caliper position, CPD or Color box position and size, the cursor, and more. The arrow keys control much of the same functionality as the touchpad.

The cursor appears in the setup pages, the patient information form, and patient report. You control the cursor through the touchpad. For example, in the patient information form, place the cursor over the last name field and press the SELECT key to activate that field. Additionally, you can use the cursor to select check boxes and items in lists.

On-screen options

The on-screen options let you make adjustments and select settings. The options available depend on context.

Each option is controlled by the pair of keys below it. Depending on the option, the control keys function in one of four ways:

Cycle Moves through a list of settings continuously. The upper control key cycles upward. The lower control key cycles downward.

Up-Down Moves through a list of settings, stopping at the top or bottom. The upper control key moves upward. The lower control key moves downward. By default, a beep sounds when you reach either end of the range. (See [“To change audio and battery settings”](#) on page 23.)

On-Off Turns a feature on or off. You can press either control key. In forms, you can instead select the option by using the touchpad and the SELECT key.

Action Performs an action. You can press either control key. Or you can instead select the option by using the touchpad and the SELECT key.

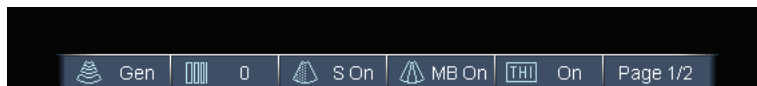
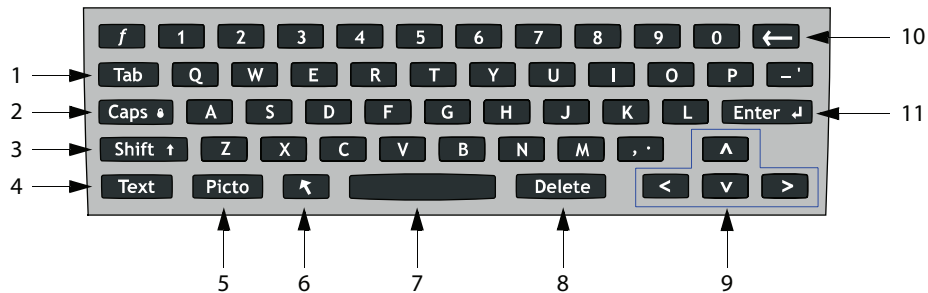

Figure 6 On-screen options (2D imaging shown)

Annotation and text

Alphanumeric keyboard



1	TAB	Moves cursor among fields in the forms, and tabs between text position in dual screens.
2	CAPS LOCK	Sets the keyboard to capital letters.
3	SHIFT	Allows entry of capitalized characters and international characters.
4	TEXT	Turns the keyboard on and off for text entry.
5	PICTO	Turns pictographs on and off.
6	ARROW	Displays an arrow graphic that can be moved and rotated within the image area.
7	SPACEBAR	Turns the keyboard on for text entry. In text entry, adds a space.
8	DELETE	Removes all text from the screen during text entry and when not measuring.
9	Arrow Keys	Move highlighted selection in calculations menu, move cursor one space when entering text, move caliper position, move cine buffer forward and backward, and move among pages in image review and reports.
10	BACKSPACE	Removes the character left of the cursor in text-entry mode.
11	ENTER	Moves cursor among fields in forms and saves calculations to report.

Symbols

You can enter symbols and special characters in select fields and forms. The symbols and special characters available depend on context.

Patient information form: Last, First, Middle, Patient ID, Accession, Indications, Procedure ID, User, Reading Dr., Referring Dr., and Institution fields

DICOM or SiteLink configuration page: Alias and AE Title fields

A & B Key, Footswitch setup page: Text field

Text mode (imaging): Annotation field

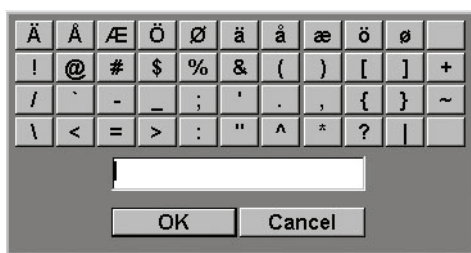

Figure 7 Symbols Dialog Box

To enter symbols or special characters

- 1 Select the field, and then select **Symbols**.
- 2 Select the desired symbol or character.
You can also press the keys on the keyboard.
- 3 Select **OK**.

Preparing transducers

WARNING: Some transducer sheaths contain natural rubber latex and talc, which can cause allergic reactions in some individuals. Refer to 21 CFR 801.437, User labeling for devices that contain natural rubber.

Some gels and sterilants can cause an allergic reaction on some individuals.

Caution: To avoid damage to the transducer, use only gels recommended by SonoSite. Using gels other than the one recommended by SonoSite can damage the transducer and void the warranty. If you have questions about gel compatibility, contact SonoSite or your local representative.

SonoSite recommends that you clean transducers after each use. See [“Cleaning and disinfecting transducers”](#) on page 99.

Acoustic coupling gel must be used during exams. Although most gels provide suitable acoustic coupling, some gels are incompatible with some transducer materials. SonoSite recommends Aquasonic® gel and provides a sample with the system.

For general use, apply a liberal amount of gel between the transducer and the body. For invasive or surgical use, install a transducer sheath.

WARNING: To prevent contamination, the use of sterile transducer sheaths and sterile coupling gel is recommended for clinical applications of an invasive or surgical nature. Do not apply the transducer sheath and gel until you are ready to perform the procedure.

To install a transducer sheath

SonoSite recommends the use of market-cleared, transducer sheaths for intracavitary or surgical applications. To lessen the risk of contamination, install the sheath only when you are ready to perform the procedure.

- 1 Place gel inside the sheath.
- 2 Insert the transducer into the sheath.
- 3 Pull the sheath over the transducer and cable until the sheath is fully extended.
- 4 Secure the sheath using the bands supplied with the sheath.
- 5 Check for and eliminate bubbles between the face of the transducer and the sheath.
Bubbles between the face of the transducer and the sheath may affect the ultrasound image.
- 6 Inspect the sheath to ensure that there are no holes or tears.

Chapter 2: System Setup

The system setup pages let you customize the system and set preferences.

To access the setup pages

- ❖ Press the SETUP key.

To return to imaging from a setup page

- ❖ Select **Done** on-screen.

A & B Key, Footswitch setup

On the A & B Key, Footswitch setup page, you can program the shortcut keys and footswitch to perform common tasks.

To program the shortcut keys and footswitch

- 1 Press the SETUP key.
- 2 Select **A & B Key, Footswitch**.
- 3 Select from the lists:

A Key, B Key The function of the shortcut keys. By default, the A shortcut key is set to **Print** and the B shortcut key is set to **Record**. The shortcut keys are below the alphanumeric keypad.

Footswitch (L), Footswitch (R) The function of the left and right footswitches: **Save Clip**, **Record**, **Freeze**, **Save Image**, or **Print**. See also “[To connect the footswitch](#)” on page 17

To connect the footswitch

The SonoSite footswitch allows hands-free operation with a customizable two-pedal footswitch. The footswitch is an optional feature.

WARNING: To avoid contamination, do not use the footswitch in a sterile environment. The footswitch is not sterilized.

- 1 Connect the cables:
 - Y adapter cable to the ECG connector on the mini-dock or docking system.
 - Footswitch cable to Y adapter cable
- 2 On the A & B Key, Footswitch setup page, select a function for the left and right footswitches.

Administration setup

On the Administration setup page, you can configure the system to require users to log in and enter passwords. Required login helps protect patient data. You can also add and delete users, change passwords, import and export user accounts, and view the event log.

Security settings

WARNING: Health care providers who maintain or transmit health information are required by the Health Insurance Portability and Accountability Act (HIPAA) of 1996 and the European Union Data Protection Directive (95/46/EC) to implement appropriate procedures: to ensure the integrity and confidentiality of information; to protect against any reasonably anticipated threats or hazards to the security or integrity of the information or unauthorized uses or disclosures of the information.

Security settings on the system allow you to meet the applicable security requirements listed in the HIPAA standard. Users are ultimately responsible for ensuring the security and protection of all electronic protected health information collected, stored, reviewed, and transmitted on the system.

To log in as Administrator

- 1 Press the **SETUP** key.
- 2 Select **Administration**.
- 3 Type *Administrator* in the **Name** box.
- 4 Type the administrator password in the **Password** box.

If you don't have the administrator password, contact SonoSite. (See [“SonoSite Technical Support”](#) on page viii.)

- 5 Select **Login**.

To log out as Administrator

- ❖ Turn off or restart the system.

To require user login

You can set the system to display the User Login screen at startup.

- 1 Log in as Administrator.
- 2 In the **User Login** list, select **On**.
 - **On** requires a user name and password at startup.
 - **Off** allows access to the system without a user name and password.

To change the administrator password or let users change passwords

- 1 Log in as Administrator.
- 2 Under **User List**, select **Administrator**.
- 3 Do any of the following:
 - Change the administrator password: Under **User Information**, type the new password in the **Password** box and **Confirm** box. (See “[Choosing a secure password](#)” on page 21.)
 - Let users change their passwords: Select the **Password changes** check box.
- 4 Select **Save**.

User setup

To add a new user

- 1 Log in as Administrator.
- 2 Select **New**.
- 3 Under **User Information**, fill in the **Name**, **Password**, and **Confirm** boxes. (See “[Choosing a secure password](#)” on page 21.)
- 4 (Optional) In the **Sonographer** box, type the user’s initials to display them in the patient header and the **User** field in the patient information form.
- 5 (Optional) Select the **Administration Access** check box to allow access to all administration privileges.
- 6 Select **Save**.

To modify user information

- 1 Log in as Administrator.
- 2 Under **User List**, select the user.
- 3 Under **User Information**, make changes as desired.
- 4 Select **Save**.

Any change to the user name replaces the previous name.

To delete a user

- 1 Log in as Administrator.
- 2 Under **User List**, select the user.
- 3 Select **Delete**.
- 4 Select **Yes**.

To change a user password

- 1 Log in as Administrator.
- 2 In the **User List**, select the user.
- 3 Type the new password in the **Password** box and **Confirm** box.
- 4 Select **Save**.

Exporting or importing user accounts

The export and import commands let you configure multiple systems and back up user account information.

To export user accounts

- 1 Insert a USB storage device.
- 2 Log in as Administrator.
- 3 Select **Export** on-screen. A list of USB devices appears.
- 4 Select the USB storage device, and select **Export**.

All user names and passwords are copied to the USB storage device.

To import user accounts

- 1 Insert the USB storage device that contains the accounts.
- 2 Log in as Administrator.
- 3 Select **Import** on-screen.
- 4 Select the USB storage device, and select **Import**.
- 5 Select **Done** in the dialog box that appears.

The system restarts. All user names and passwords on the system are replaced with the imported data.

Exporting and clearing the Event log

The Event log collects errors and events and can be exported to a USB storage device and read on a PC.

To view the Event log

- 1 Log in as Administrator.
- 2 Select **Log** on-screen.

The Event log appears.

To return to the previous screen, select **Back**.

To export the Event log

The Event log and the DICOM network log have the same file name (log.txt). Exporting either one to a USB storage device overwrites any existing log.txt file.

- 1 Insert a USB storage device.
- 2 Select **Log** and then select **Export** on-screen.
A list of USB devices appears.
- 3 Select the USB storage device, and select **Export**.

The Event log is a text file that you can open in a text-editing application (for example, Microsoft Word or Notepad).

To clear the Event log

- 1 View the Event log.
- 2 Select **Clear** on-screen.
- 3 Select **Yes**.

Logging in as user

If user login is required, the User Login screen appears when you turn on the system. (See “To require user login” on page 18.)

To log in as user

- 1 Turn on the system.
- 2 In the **User Login** screen, type your name and password, and select **OK**.

To log in as guest

Guests can scan but can't access system setup and patient information.

- 1 Turn on the system.
- 2 In the **User Login** screen, select **Guest**.

To change your password

- 1 Turn on the system.
- 2 In the **User Login** screen, select **Password**.
- 3 Type your old and new passwords, confirm the new password, and then select **OK**.

Choosing a secure password

To ensure security, choose a password that contains uppercase characters (A-Z), lowercase characters (a-z), and numbers (0-9). Passwords are case-sensitive.

Annotations setup

On the Annotations setup page, you can customize predefined labels and set the preference for managing text when unfreezing images.

For instructions to annotate images, see “Annotations” on page 43.

To predefine a label group

You can specify which labels are available for an exam type when annotating an image. (See “To place text on an image” on page 44.)

- 1 Press the **SETUP** key.
- 2 Select **Annotations**.
- 3 In the **Exam** list, select the exam type whose labels you want to specify.
- 4 For **Group**, select **A**, **B**, or **C** for the label group you want associated with that exam.
The preset labels appear for the selected group.
- 5 Do any of the following:
 - Add a custom label to the group: Type the label in the **Text** box, and select **Add**.
 - Rename a label: Select the label, type the new name in the **Text** box, and select **Rename**.
 - Move a label within the group: Select the label, and then select the on-screen up or down arrow.
 - Delete a label from a group: Select the label, and select **Delete**.

You can use symbols in labels. See “Symbols” on page 15.

To specify text retention when unfreezing

You can specify which text to keep when you unfreeze an image or change the imaging layout.

- 1 Press the **SETUP** key.
- 2 Select **Annotations**.
- 3 In the **Unfreeze** list, select **Keep All Text**, **Keep Home Text**, or **Clear All Text**.

The default setting is **Keep All Text**. For information on setting the home position, see “To reset the home position” on page 44.

To export predefined label groups

- 1 Insert a USB storage device.
- 2 Press the **SETUP** key.
- 3 Select **Annotations**.

- 4 Select **Export**. A list of USB devices appears.
- 5 Select the USB storage device, and select **Export**.

A copy of all predefined label groups for all exams saves to the USB storage device.

To import predefined label groups

- 1 Insert the USB storage device that contains the label groups.
- 2 Press the SETUP key.
- 3 Select **Annotations**.
- 4 Select **Import** on-screen.
- 5 Select the USB storage device, and then select **Import**.
- 6 Select **Done** in the dialog box that appears.

The system restarts. All predefined label groups for all exams are replaced with those from the USB storage device.

Audio, Battery setup

On the Audio, Battery setup page, you can specify sounds and the length of time for Sleep Delay and Power Delay.

To change audio and battery settings

- 1 Press the SETUP key.
- 2 Select **Audio, Battery**.
- 3 Specify options in the following lists:
 - Key click:** Select **On** or **Off** for keys to click when pressed.

Beep alert: Select **On** or **Off** for the system to beep when saving, warning, starting, or shutting down.

Sleep delay: Select **Off**, or **5** or **10** minutes to specify the period of inactivity before the system goes into sleep mode.

Power delay: Select **Off**, or **15** or **30** minutes to specify the period of inactivity before the system automatically turns off.

Cardiac Calculations setup

On the Cardiac Calculations setup page, you can specify measurement names that appear in the Tissue Doppler Imaging (TDI) calculations menu and on the report page.

See also “[Cardiac calculations](#)” on page 68.

To specify cardiac measurement names

- 1 Press the SETUP key.
- 2 Select **Cardiac Calculations**.
- 3 In the **TDI Walls** lists, select names for each wall.

Connectivity setup

On the Connectivity setup page, you specify options for using devices and for alerts when internal storage is full. You also specify settings (including Transfer Mode and Location) for SiteLink and DICOM, which are optional features. Refer to the SiteLink and DICOM documentation.

To configure the system for a printer

- 1 Set up the printer hardware. (See instructions included with the printer or docking system.)
- 2 Press the SETUP key.
- 3 Select **Connectivity**.
- 4 In the **Printer** list, select the printer.

To configure the system for a DVD recorder, PC, or bar code scanner

- 1 Press the SETUP key.
- 2 Select **Connectivity**.
- 3 (DVD recorder) In the **Video Mode** list, select the video standard: **NTSC** or **PAL**.
- 4 In the **Serial Port** list, select the peripheral.

Note: Because these peripherals use the same RS-232 connector on the mini-dock, you can connect only one of them at a time.

Computer (PC) allows report data to be sent as ASCII text from the system to a PC. The PC must have third-party software to acquire, view, or format the data into a report. Check the compatibility of your software with SonoSite Technical Support. (See also “Sending reports and viewing EMED worksheets” on page 94.)

- 5 Select **Yes** to restart the system.
- 6 Attach a serial cable (RS-232) from the serial port on the mini-dock or docking system to the peripheral.

To receive storage alerts

- 1 Press the SETUP key.
- 2 Select **Connectivity**.

3 Select **Internal Storage Capacity Alert**.

The system displays a message if internal storage is near capacity when you end an exam. The system then deletes archived patient exams if specified in DICOM.

Date and Time setup

WARNING: To obtain accurate obstetrics calculations, an accurate date and time are critical. Verify that the date and time are accurate before each use of the system. The system does not automatically adjust for daylight saving time changes.

To set the date and time

- 1 Press the SETUP key.
- 2 Select **Date and Time**.
- 3 In the **Date** box, type the current date.
- 4 In the **Time** box, type the current time in 24 hour format (hours and minutes).

Display Information setup

On the Display Information setup page, you can specify which details appear on-screen during imaging.

To specify display information

- 1 Press the SETUP key.
- 2 Select **Display Information**.
- 3 Select settings in the following sections:
 - **Patient Header** Information that appears in the patient header.
 - **Mode Data** Imaging information.
 - **Network Status** System status information.

IMT Calculations setup

On the IMT Calculations setup page, you can customize the IMT calculations menu. You can specify up to eight measurement names for both right side and left side calculations. The measurement names also appear in the patient report.

See also “[IMT calculations](#)” on page 80.

To customize the IMT calculations menu

- 1 Press the SETUP key.

- 2 Select **IMT Calculations**.
- 3 Under **IMT Calculations**, select measurement names from the lists, or select **None**.
The selected names appear in the calculations menu and in the patient report.
- 4 Type the desired width in the **Region width (mm)** box.

Network Status setup

The Network Status setup page displays information on system IP address, Location, WLAN Profile, Active WLAN SSID, and Ethernet MAC address.

To display network status information

- 1 Press the SETUP key.
- 2 Select **Network Status**.

OB Calculations setup

On the OB Calculations setup page, you select authors for OB calculation tables. You can also import or export additional OB calculation tables.

See also “OB calculations” on page 83.

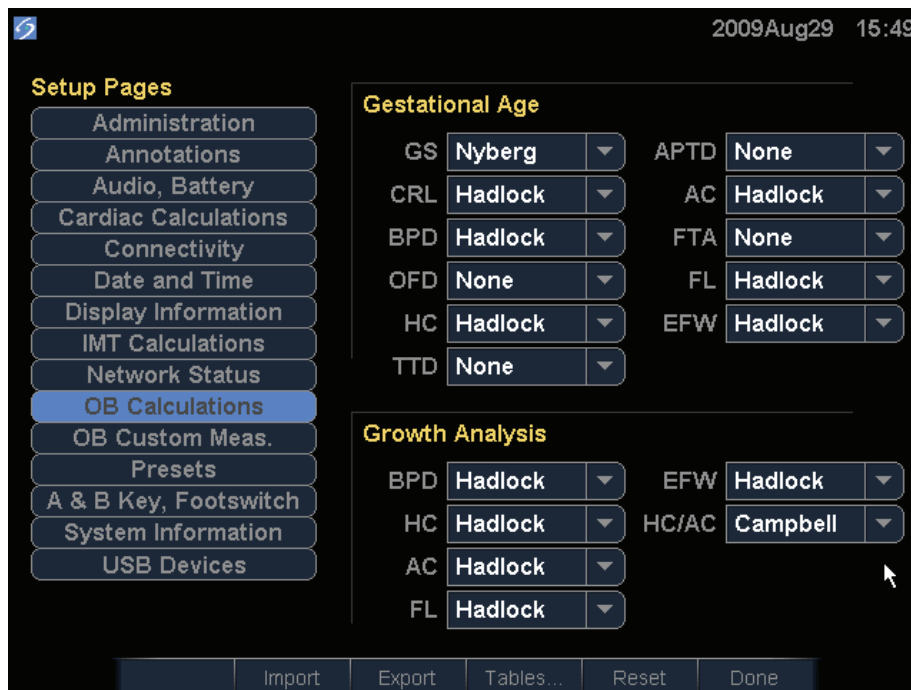

Figure 1 OB Calculations Setup Page

To specify gestational age and growth analysis

- 1 Press the **SETUP** key.
- 2 Select **OB Calculations**.
- 3 In the measurement lists under **Gestational Age** and **Growth Analysis**, select the desired OB authors, or select **None**.

Selecting an author places the associated measurement on the calculations menu.

- 4 (Optional) Select **More** to display the list of user-defined custom measurements and to associate a custom table for the custom measurement.

This option is available only when a user-defined custom table has been created for the custom measurement.

To export OB calculation tables

- 1 Insert a USB storage device.
- 2 Press the **SETUP** key.
- 3 Select **OB Calculations**.
- 4 Select **Export**. A list of USB devices appears.
- 5 Select the USB storage device, and select **Export**.

All user-defined tables and measurements are copied to the USB storage device.

To import OB calculation tables

Imported OB calculation tables replace all user-defined tables and measurements on the system.

- 1 Insert the USB storage device that contains the tables.
- 2 Press the **SETUP** key.
- 3 Select **OB Calculations**.
- 4 Select **Import** on-screen.
- 5 Select the USB storage device, and then select **Import**.
- 6 Select **Done** in the dialog box that appears.

The system restarts.

OB Custom Measurements setup

On the OB Custom Measurements setup page, you can define measurements that appear in the OB calculations menu and OB report. OB Custom Measurements is an optional feature.

See also “OB calculations” on page 83.

To set up OB custom measurements

You can save up to five custom measurements that appear in the OB calculations menu and OB report.

- 1 Press the **SETUP** key.
- 2 Select **OB Custom Meas.**
- 3 Select **New**.
- 4 In the **Name** box, type a unique name.
- 5 In the **Type** list, select the desired measurement type.
- 6 Select **Save**.

To delete an OB custom measurement

- 1 Press the **SETUP** key.
- 2 Select **OB Custom Meas.**
- 3 In the **Custom Measurements** list, highlight the last measurement.
- 4 Select **Delete Last**.
- 5 Select **Yes**.

Any tables and report data associated with the measurement are removed from the system.

OB Custom Tables setup

On the OB Custom Tables setup pages, you can customize growth tables that appear in the calculations menu and patient report.

Gestational Age Table Measurements The system provides gestational age measurements by selected authors for CRL, GS, BPD, OFD, HC, AC, FL, APTD, TTD, FTA, and 5 additional custom measurement labels.

Growth Analysis Table Measurements The system provides growth graphs or curves for BPD, HC, AC, FL, EFW, and HC/AC.

WARNING: Prior to use, verify that custom table data entries are correct. The system does not confirm the accuracy of the custom table data entered by the user.

To view OB tables

- 1 Press the **SETUP** key.
- 2 Select **OB Custom Meas.** or **OB Calculations**.
- 3 Select **Tables** on-screen.
- 4 Select the desired table and measurement/author.

To create a new OB custom table

You can create two custom tables for each OB measurement. Growth analysis tables cannot be created for custom OB measurements.

- 1 Press the **SETUP** key.
- 2 Select **OB Custom Meas.** or **OB Calculations**.
- 3 Select **Tables** on-screen.
- 4 Select the desired table (**Gestational Age** or **Growth Analysis**).
- 5 In the **Measurement** list, select the measurement for the custom table.
- 6 Select **New** on-screen.
- 7 In the **Author** box, type a unique name.
- 8 Enter the data.
- 9 Select **Save** on-screen.

To display the measurement for the custom table in the calculations menu, see [“To specify gestational age and growth analysis”](#) on page 27.

To edit or delete an OB custom table

- 1 Press the **SETUP** key.
- 2 Select **OB Custom Meas.** or **OB Calculations**.
- 3 Select **Tables** on-screen.
- 4 Select the OB custom table.
- 5 Select one of the following on-screen:
 - **Edit** Enter data, and then select **Save** on-screen.
 - **Delete** to remove the custom table.

Presets setup

The Presets setup page has settings for general preferences.

To set presets

- 1 Press the **SETUP** key.
- 2 Select **Presets**.
- 3 Select from the lists:

Doppler Scale Select **cm/s** or **kHz**.

Duplex The layout for displaying M Mode trace and Doppler spectral trace: **1/3 2D, 2/3 Trace; 1/2 2D, 1/2 Trace;** or **Full 2D, Full Trace**.

Live Trace Select **Peak** or **Mean**.

Thermal Index You can select **TIS**, **TIB**, or **TIC**. The default setting is based on exam type: OB is **TIB**, TCD is **TIC**, and all others are **TIS**.

Save Key Behavior of the SAVE key. **Image Only** saves the image to internal storage. **Image/Calcs** saves the image to internal storage and saves the current calculation to the report.

Dynamic Range Settings include **-3**, **-2**, **-1**, **0**, **+1**, **+2**, or **+3**. Negative numbers show higher contrast images, and positive numbers show lower contrast images.

Units Units for patient height and weight in cardiac exams: **in/ft/lbs** or **cm/m/kg**.

Language The system language. Changing the language requires restarting the system.

Color Scheme The background color of the display.

Auto save Pat. Form Automatically saves the patient information form as an image in the patient's file.

System Information setup

The System Information setup page displays system hardware and software versions, and license information.

See also [“To enter a license key”](#) on page 97.

To display system information

- 1 Press the SETUP key.
- 2 Select **System Information**.

USB Devices setup

On the USB Devices setup page, you can view information about connected USB devices, including space availability. You can also specify a file format for images and clips you export to a USB storage device. (See [“To export images or clips to a USB storage device”](#) on page 52.)

To specify a file format for exported images

- 1 Press the SETUP key.
- 2 Select **USB Devices**.
- 3 Select **Export**.
- 4 Under USB Export, select an export type:

- **SiteLink** organizes files in a SiteLink-style folder structure. Clips export in H.264 video saved as MP4 files. To view them, SonoSite recommends QuickTime 7.0 or later.
 - **DICOM** creates files readable by a DICOM server. DICOM is an optional feature.
- 5** Select an image format for your export type. For JPEG image format, also select a JPEG compression.
- A high compression has a smaller file size but less detail.
- For SiteLink export type, the image format affects only still images. For DICOM export type, the image format affects both still images and clips.
- 6** For **SiteLink** export type, select a sort order under **Sort By**.
- To return to the previous screen, select **Devices**.

Restoring default settings

To restore default settings for a setup page

- ❖ On the setup page, select **Reset** on-screen.

To restore all default settings

- 1** Turn the system off.
- 2** Connect the system to AC power. (See [“To operate the system using AC power”](#) on page 6.)
- 3** Simultaneously press **1** and the power key.
The system beeps several times.

Chapter 3: Imaging

Imaging modes

The system has a high-performance LCD and advanced image-optimization technology that greatly simplifies user controls. Imaging modes available depend on the transducer and exam type. See “Imaging modes and exams available by transducer” on page 42.

Adjusting depth and gain



To adjust depth

You can adjust the depth in all imaging modes but the trace modes. The vertical depth scale is marked in 0.5 cm, 1 cm, and 5 cm increments, depending on the depth.

- ❖ Press the following keys:
 - UP DEPTH key to decrease the displayed depth.
 - DOWN DEPTH key to increase the displayed depth.

As you adjust the depth, the maximum depth number changes in the lower right screen.

To adjust gain

- ❖ Do one of the following:
 - To adjust gain automatically, press the AUTO GAIN key. The gain adjusts each time you press this key.
 - To adjust gain manually, turn the NEAR , FAR , and GAIN  knobs. These knobs increase or decrease the amount of gain applied to the near field, far field, or the overall image. (*Near* and *far* correspond to the time gain compensation [TGC] controls on other ultrasound systems.)
 - In PW and CW Doppler imaging, the GAIN knob affects Doppler gain.
 - In CPD or Color imaging, the GAIN knob affects the color gain applied to the region of interest (ROI) box. The NEAR and FAR knobs affect only the 2D image.

Freezing, viewing frames, and zooming

To freeze or unfreeze an image

- ❖ Press the FREEZE key.
 - On a frozen image, the cine icon and frame number appear in the system status area.

To move forward or backward in the cine buffer

❖ Freeze the image, and do one of the following:

- Turn the  knob.
- Use the touchpad. Right moves forward, and left moves backward.
- Press the LEFT ARROW and RIGHT ARROW keys.

The frame number changes as you move forward or backward. The total number of frames in the buffer appears on-screen in the system status area.

To zoom in on an image

You can zoom in 2D and Color imaging. You can freeze or unfreeze the image or change the imaging mode at any time while zooming.

1 Press the ZOOM key. A ROI box appears.

2 Using the touchpad, position the ROI box as desired.

3 Press the ZOOM key again.

The image in the ROI box is magnified by 100%.

4 (Optional) If the image is frozen, use the touchpad or arrow keys to pan the image up, down, left, and right. (You cannot pan in Dual.)

To exit zoom, press the ZOOM key again.

Changing the exam type

The exam types available depend on transducer used. See [“Imaging modes and exams available by transducer”](#) on page 42.

To change the exam type

❖ Do one of the following:

- Press the EXAM key, and select from the menu.
- On the patient information form, select from the **Type** list under **Exam**. (See [“Patient information form”](#) on page 45.)

2D imaging

2D is the system's default imaging mode. The system displays echoes in two dimensions by assigning a brightness level based on the echo signal amplitude. To achieve the best possible image quality, properly adjust the display brightness, gain, depth settings, viewing angle, and exam type. Also, select an optimization setting that best matches your needs.





To display the 2D image

- 1 Do any of the following:
 - Turn on the system.
 - Press the 2D key.
- 2 Set options as desired. See “2D options.”





2D options

In 2D imaging, you can select the following on-screen options.

2D options

Option	Icon	Description
Optimize		<p>Settings are as follows:</p> <ul style="list-style-type: none"> • Res provides the best possible resolution. • Gen provides a balance between resolution and penetration. • Pen provides the best possible penetration. <p>Some of the parameters optimized to provide the best image include focal zones, aperture size, frequency (center and bandwidth), and waveform. They cannot be adjusted by the user.</p>
Dynamic Range		<p>Adjusts the grayscale range: -3, -2, -1, 0, +1, +2, +3.</p> <p>The positive range increases the number of grays displayed, and the negative range decreases the number of grays displayed.</p>
Dual		<p>Displays side-by-side 2D images.</p> <p>Select Dual, and then press the UPDATE key to display the second screen and to toggle between the screens. With both images frozen, press the UPDATE key to toggle between the images.</p> <p>To return to full-screen 2D imaging, select Dual or press the 2D key.</p>
LVO On, LVO Off		<p>LVO On turns on Left Ventricular Opacification. LVO Off turns off this option.</p> <p>Use LVO for cardiac exams in 2D imaging mode when using an imaging contrast agent. LVO lowers the mechanical index (MI) of the system to enhance visualization of the contrast agent and endocardial border.</p> <p>This option depends on transducer and exam type.</p>
Orientation		<p>Select from four image orientations: U/R (Up/Right), U/L (Up/Left), D/L (Down/Left), D/R (Down/Right).</p>

2D options (Continued)

Option	Icon	Description
Brightness		Adjusts the display brightness. Settings range from 1 to 10 . The display brightness affects battery life. To conserve battery life, adjust brightness to a lower setting.
Biopsy		Turns biopsy guidelines on and off. This feature depends on transducer type. See the SonoSite Biopsy user guide. Biopsy is not available when the ECG cable is connected.
Guide		Turns the guideline on and off. This feature depends on transducer and exam type. See the user guide for L25x transducer and needle guide.
SonoHD (S)		S On and S Off turn SonoHD™ Imaging Technology on and off. When SonoHD is on, <i>S</i> appears in the upper left-hand screen. SonoHD is optional and depends on transducer and exam type.
SonoMB (MB)		MB On and MB Off turn SonoMB™ multi-beam technology on and off. When SonoMB is on, <i>MB</i> appears in the upper left-hand screen. SonoMB depends on transducer and exam type.
ECG		Displays the ECG trace. See “ ECG Monitoring ” on page 52. This feature is optional and requires a SonoSite ECG cable.
Clips		Displays the clips options. See “ To capture and save a clip ” on page 48. This feature is optional.
THI		Turns Tissue Harmonic Imaging on and off. When on, <i>THI</i> appears in the upper left-hand screen. This feature is optional and depends on transducer and exam type.
Page x/x		Indicates which page of options is displayed. Select to display the next page.

M Mode imaging

Motion mode (M Mode) is an extension of 2D. It provides a trace of the 2D image displayed over time. A single beam of ultrasound is transmitted, and reflected signals are displayed as dots of varying intensities, which create lines across the screen.

To display the M-line

- 1 Press the M MODE key.

Note: If the M-line does not appear, make sure that the system is in live imaging.

- 2 Use the touchpad to position the M-line where desired.
- 3 Set options as desired.

Many optimization and depth options available in 2D imaging are also available in M Mode imaging. See [“2D options”](#) on page 35.

To display the M Mode trace

- 1 Display the M-line.
- 2 Adjust the depth if necessary. (See [“To adjust depth”](#) on page 33.)
- 3 Press the M MODE key.

The time scale above the trace has small marks at 200ms intervals and large marks at one-second intervals.

- 4 Do any of the following as needed:
 - Select the sweep speed  (Slow, Med, or Fast).
 - Press the UPDATE key to toggle between the M-line and M-Mode trace.
 - If using a duplex layout, press the M MODE key to toggle between the full-screen M-line and the duplex layout.

To set a duplex layout, see [“Presets setup”](#) on page 29.

CPD and color Doppler imaging

Color power Doppler (CPD) and color Doppler (Color) are optional features.

CPD is used to visualize the presence of detectable blood flow. Color is used to visualize the presence, velocity, and direction of blood flow in a wide range of flow states.

To display the CPD or Color image

- 1 Press the COLOR key.

A ROI box appears in the center of the 2D image.

- 2 Select **CPD** or **Color**.

The current selection also appears in the upper left-hand screen.

The Color indicator bar on the upper left-hand screen displays velocity in cm/s in Color imaging mode only.

- 3 Using the touchpad, position or resize the ROI box as needed. Press the SELECT key to toggle between position and size.









While you position or resize the ROI box, a green outline shows the change. The ROI box indicator on the left-hand screen shows which touchpad function is active.

- 4 Set options as desired. See [“CPD and Color options.”](#)

CPD and Color options

In CPD or Color imaging, you can set the following on-screen options.

CPD and Color options

Option	Icon	Description
Color, CPD		Toggle between CPD and Color. The current selection appears in the upper left-hand screen.
Color Suppress		Shows or hides color information. You can select Show or Hide while in live or frozen imaging. The setting shown on-screen is the current selection.
Flow Sensitivity		The current setting appears on-screen. <ul style="list-style-type: none">• Low optimizes the system for low flow states.• Med optimizes the system for medium flow states.• High optimizes the system for high flow states.
PRF Scale		Select the desired pulse repetition frequency (PRF) setting by pressing the control keys. There is a wide range of PRF settings for each Flow Sensitivity setting (Low, Med, and High). Available on select transducers.
Wall Filter		Settings include Low , Med , and High . Available on select transducers.
Steering		Select the steering angle setting of the color ROI box (-15, +0, or +15). If adding PW Doppler, see " PW Doppler options " on page 40. Available on select transducers.
Variance		Turns variance on and off. Available only for cardiac exam.
Invert		Switches the displayed direction of flow. Available in Color imaging.
Page x/x		Indicates which page of options is displayed. Select to display the next page.

PW and CW Doppler imaging

Pulsed wave (PW) Doppler and continuous wave (CW) Doppler imaging modes are optional features.

PW Doppler is a Doppler recording of blood flow velocities in a range specific area along the length of the beam. CW Doppler is a Doppler recording of blood flow velocities along the length of the beam.

You can use PW/CW Doppler and CPD/Color and simultaneously. If CPD/Color imaging is on, the color ROI box is tied to the D-line. The SELECT key cycles among color ROI box position, color ROI box size, the D-line, and (in PW Doppler) angle correction. The active selection is green. Also, the indicator on the left-hand screen shows which touchpad function is active.

To display the D-line

The default Doppler imaging mode is PW Doppler. In cardiac exams, you can select the CW Doppler on-screen option.

- 1 Press the DOPPLER key.

Note: If the D-line does not appear, make sure that the system is in live imaging.

- 2 Do any of the following as needed:

- Set options. See “PW Doppler options” on page 40.
- Using the touchpad, position the D-line where desired.
- (PW Doppler) To correct the angle manually, press the SELECT key and then use the touchpad to adjust the angle in 2° increments from -74° to +74°. Press the SELECT key again to set the desired angle.

The SELECT key toggles between the D-line and angle correction.

To display the spectral trace

- 1 Display the D-line.

- 2 Press the DOPPLER key.

The time scale above the trace has small marks at 200 ms intervals and large marks at one-second intervals.

- 3 Do any of the following as needed:





- Set options. See “Spectral trace options” on page 41.
- Press the UPDATE key to toggle between the D-line and spectral trace.
- If using a duplex layout, press the DOPPLER key to toggle between the full-screen D-line and the duplex layout.

To set a duplex layout, see “Presets setup” on page 29.

PW Doppler options

In PW Doppler imaging, you can set the following on-screen options.







PW Doppler options

Option	Icon	Description
PW, CW		(Cardiac exam only) Toggle between PW Doppler and CW Doppler. The current selection appears in the upper left-hand screen.
Angle Correction		Corrects the angle to 0° , +60° , or -60° .
Gate Size		Settings depend on transducer and exam type.
TDI On, TDI Off		Select TDI On to turn on tissue Doppler imaging. When on, <i>TDI</i> appears in the upper left-hand screen. The default is TDI off . Available only in cardiac exams.
Steering		Select the desired steering angle setting. The PW Doppler angle correction automatically changes to the optimum setting. <ul style="list-style-type: none">• -15 has an angle correction of -60°.• +0 has an angle correction of 0°.• +15 has an angle correction of +60°. You can manually correct the angle after selecting a steering angle setting. (See “To display the D-line” on page 39.) Available on select transducers.
Page x/x		Indicates which page of options is displayed. Select to display the next page.

Spectral trace options

In spectral trace imaging, you can set the following on-screen options.

Spectral trace options

Option	Icon	Description
Scale		Select the desired scale (pulse repetition frequency [PRF]) setting. (To change the Doppler scale to cm/s or kHz, see “Presets setup” on page 29.)
Line		Sets the baseline position. (On a frozen trace, the baseline can be adjusted if Live Trace is off.)
Invert		Vertically flips the spectral trace. (On a frozen trace, Invert is available if Live Trace is off.)
Volume		Increases or decreases Doppler speaker volume (0-10).
Wall Filter		Settings include Low, Med, High .
Sweep Speed		Settings include Slow, Med, Fast .
Live Trace		Displays a live trace of the peak or mean. (See “Presets setup” on page 29 to specify peak or mean.)
Page x/x		Indicates which page of options is displayed. Select to display the next page.

Imaging modes and exams available by transducer

WARNING: To prevent misdiagnosis or harm to the patient, understand your system's capabilities prior to use. The diagnostic capability differs for each transducer, exam type, and imaging mode. In addition, transducers have been developed to specific criteria depending on their physical application. These criteria include biocompatibility requirements.

The transducer you use determines which exam types are available. In addition, the exam type you select determines which imaging modes are available.

Imaging modes and exams available by transducer

Transducer	Exam Type ¹	Imaging Mode				
		2D ² M Mode	CPD ³	Color ³	PW Doppler	CW Doppler
C11x	Abd	X	X	X	X	—
	Neo	X	X	X	X	—
	Nrv	X	X	X	X	—
	Vas	X	X	X	X	—
C60x	OB	X	X	X	X	—
	Gyn	X	X	X	X	—
	Abd	X	X	X	X	—
	Nrv	X	X	X	X	—
HFL38x	Bre	X	X	X	X	—
	SmP	X	X	X	X	—
	Vas	X	X	X	X	—
	Msk	X	X	X	X	—
	IMT	X	X	X	X	—
	Nrv	X	X	X	X	—
	Ven	X	X	X	X	—
ICTx	Gyn	X	X	X	X	—
	OB	X	X	X	X	—

Imaging modes and exams available by transducer (Continued)

Transducer	Exam Type ¹	Imaging Mode				
		2D ² M Mode	CPD ³	Color ³	PW Doppler	CW Doppler
L25x	Msk	X	X	X	X	—
	Vas	X	X	X	X	—
	Nrv	X	X	X	X	—
	Sup	X	X	X	X	—
	Ven	X	X	X	X	—
L38x	Bre	X	X	X	X	—
	SmP	X	X	X	X	—
	Vas	X	X	X	X	—
	IMT	X	X	X	X	—
	Nrv	X	X	X	X	—
	Ven	X	X	X	X	—
P21x	Abd	X	X	X	X	—
	OB	X	X	X	X	—
	Crd	X	—	X	X	X

1. Exam type abbreviations are as follows: Abd = Abdomen, Bre = Breast, Crd = Cardiac, Gyn = Gynecology, IMT = Intima Media Thickness, Msk = Muscle, Neo = Neonatal, Nrv = Nerve, OB = Obstetrical, SmP = Small Parts, Sup = Superficial, Vas = Vascular, Ven = Venous

2. The optimization settings for 2D are Res, Gen, and Pen.

3. The optimization settings for CPD and Color are low, medium, and high (flow sensitivity) with a range of PRF settings for Color depending on the setting selected.

Annotations

You can annotate live images as well as frozen images. (You cannot annotate a saved image.) You can place text (including predefined labels), an arrow, or a pictograph. To set preferences for annotations, see [“Annotations setup”](#) on page 22.

To place text on an image

You can place text in the following imaging layouts: full-screen 2D, full-screen trace, dual, or duplex. You can place text manually or add a predefined label.

- 1 Press the TEXT key. A green cursor appears.
- 2 Move the cursor where desired:
 - Use the touchpad or arrow keys.
 - Select **Home** to move the cursor to the home position.
The default home position depends on the imaging screen layout. You can reset the home position. See [“To reset the home position”](#) on page 44.
- 3 Using the keyboard, type text.
 - The arrow keys move the cursor left, right, up, and down.
 - The DELETE key deletes all text.
 - The **X Word** option removes a word.
 - Select **Symbols** to enter special characters. See [“Symbols”](#) on page 15.
- 4 (Optional) To add a predefined label, select **Label**, and then select the desired label group (**1/x**).

There are three label groups. See [“Annotations setup”](#) on page 22.

To turn off text entry, press the TEXT key.

To reset the home position

- 1 Press the TEXT key.
- 2 Using the touchpad or arrow keys, position the cursor where desired.
- 3 Select **Home/Set**.

To place an arrow on an image

You can add an arrow graphic to point out a specific part of the image.

- 1 Press the ARROW key .
- 2 If you need to adjust the arrow's orientation, press the SELECT key and then use the touchpad. When the orientation is correct, press the SELECT key again.
- 3 Use the touchpad to move the arrow to the desired location.
- 4 Press the ARROW key to set the arrow.

The arrow changes from green to white.

To remove the arrow, press the ARROW key and then select **Hide**.

To place a pictograph on an image

The pictograph set available depends on transducer and exam type.

- 1 Press the PICTO key.
- 2 Select  **x/x** to display the desired pictograph, and then press the SELECT key.
The first number shows which pictograph in the set has been selected. The second number is the number of pictographs available.
- 3 Use the touchpad to position the pictograph marker.
- 4 (Optional) To rotate the pictograph marker, press the SELECT key and then use the touchpad.
- 5 Select a screen location for the pictograph: **U/L** (Up/Left), **D/L** (Down/Left), **D/R** (Down/Right), **U/R** (Up/Right).
In a duplex layout, the pictograph is restricted to upper left. In Dual, all four positions are available.

To remove the pictograph, select **Hide**.

Patient information form

The patient information form lets you enter patient identification, exam, and clinical information for the patient exam. This information automatically appears in the patient report.

When you create a new patient information form, all images and other data you save during the exam are linked to that patient. (See “Patient report” on page 92.)

To create a new patient information form

Note: Creating a new patient information form erases any unsaved patient information, including any calculations and report page. To save this information, save the screen for each item.

- 1 Press the PATIENT key.
- 2 Select  **New**.
- 3 Fill in the form fields. See “Patient information form fields” on page 46.
- 4 Select **Done**.

To edit a patient information form

You can edit patient information during the exam. However, if you change the patient name, ID, date of birth, gender, or accession after saving an image, a new patient information form is created.

- 1 Press the PATIENT key.
- 2 If you need to change the name, ID, date of birth, gender, or accession, save any data you want to keep.

- 3 Make changes as desired.
- 4 Select one of the following:
 - **Cancel** to undo changes and return to imaging.
 - **Done** to save changes and return to imaging.

To end the exam

- 1 Make sure that you have saved images and other data you want to keep. (See [“Saving images and clips”](#) on page 48.)
- 2 Press the PATIENT key.
- 3 Do one of the following:
 - Select **End Exam**.
 - Select  **New** to begin a new patient information form. (See [“To create a new patient information form”](#) on page 45.)

Patient information form fields

The patient information form fields available depend on exam type. In some fields you can select Symbols to enter symbols and special characters. See [“Symbols”](#) on page 15.

Patient information form fields

Section	Field	Description
Patient	Last First Middle	Patient name
	ID	Patient identification number
	Accession	Enter number, if applicable.
	Date of birth	Date of birth
	Gender	Female, Male, Other , or blank
	Indications	Enter desired text
	User	User initials
	More button	Displays the Reading Dr., Referring Dr., and Institution fields. Select Back to save entries and return to previous screen.

Patient information form fields (Continued)

Section	Field	Description
Exam	Type	Exam types available depend on transducer. See “Imaging modes and exams available by transducer” on page 42. For the definition of abbreviations, see “Glossary” on page 179.
	LMP Estab. DD	(OB or Gyn exam) In an OB exam, select LMP or Estab. DD and then enter either the date of the last menstrual period or the established due date. In a Gyn exam, enter the date of the last menstrual period. The LMP date must precede the current system date.
	Twins	(OB exam) Select the Twins check box to display Twin A and Twin B measurements on the calculations menu and to have Twin A and Twin B screens for previous exam data.
	Previous Exams button	(OB exam) Displays fields for five previous exams. The date for a previous exam must precede the current system date. For twins, select Twin A/B to toggle between Twin A and Twin B screens. (If the Twin A/B option does not appear, select Back , and make sure that the Twins check box is selected.) Select Back to save changes and return to previous screen.
	BP	(Cardiac, IMT, or Vascular exam) Blood Pressure
	HR (Heart Rate)	(Cardiac or Vascular exam) Enter the beats per minute. Saving the heart rate using a measurement overwrites this entry.
	Height	(Cardiac exam) The patient height in feet and inches or meters and centimeters. (To change the units, see “Presets setup” on page 29.)
	Weight	(Cardiac exam) The patient weight in pounds or kilos. (To change the units, see “Presets setup” on page 29.)
	BSA	(Cardiac exam) Body Surface Area. Automatically calculated after you enter height and weight.
	Ethnicity	(IMT exam) Ethnic origin

Patient information form fields (Continued)

Section	Field	Description
Procedure	Type	Available if the DICOM Worklist feature is licensed and configured. See the DICOM user guide.
	ID	Available if the DICOM Worklist feature is licensed and configured. See the DICOM user guide.

Saving images and clips

Clips, an optional feature, lets you capture, preview, and save clips.

When you save an image or clip, it saves to internal storage. The system beeps afterward if Beep Alert is on, and the percentage icon flashes. (See [“Audio, Battery setup”](#) on page 23.) To access saved images and clips, open the patient list. (See [“Patient list”](#) on page 50.)

The percentage icon in the system status area shows the percentage of space used in internal storage. To receive alerts when storage is near capacity, see [“To receive storage alerts”](#) on page 24.

To save an image

❖ Press the SAVE key.

The image saves to internal storage.

By default, the SAVE key saves only the image. As a shortcut during calculations, the SAVE key can save both the image to internal storage and the calculation to the patient report. See [“To set presets”](#) on page 29.

To capture and save a clip

1 Set Clips options. (See [“To set Clips options”](#) on page 49.)

2 Press the CLIP key.

One of the following occurs:

- If **Prev/Off** is selected, the clip saves directly to internal storage.
- If **Prev/On** is selected, the clip plays back in preview mode. You can select any of the following on-screen:
 - A playback speed  (1x, 1/2x, 1/4x)
 - **Pause** to interrupt playback
 - **Left: x** or **Right: x** to remove frames from the left or right sides of the clip (where x is the beginning or ending frame number)



- **Save** to save the clip to internal storage
- **Delete** to delete the clip

To set Clips options

Setting Clips options ensures that clips are captured to your specifications.

- 1 In 2D imaging mode, select **Clips** on-screen.
- 2 Set options as desired.

Clips options

Option	Icon	Description
Time, ECG		<p>Time and ECG share the same location on-screen.</p> <ul style="list-style-type: none"> • With Time, capturing is based on number of seconds. Select the time duration. • With ECG, capturing is based on the number of heart beats. Select the number of beats.
Preview On, Preview Off		<p>PrevOn and PrevOff turn the preview feature on and off.</p> <ul style="list-style-type: none"> • With Prev/On, the captured clip automatically plays on-screen. The clip can be trimmed, saved, or deleted. • With Prev/Off, the clip saves to internal storage, and the trim and delete options are not available.
Prospective, Retrospective		<p>Pro and Retro determine how clips are captured:</p> <ul style="list-style-type: none"> • With Pro, a clip is captured prospectively, after you press the CLIP key. • With Retro, a clip is captured retrospectively, from pre-saved data before you press the CLIP key.

Patient list

WARNING: To avoid damaging the USB storage device and losing patient data from it, observe the following:

- Do not remove the USB storage device or turn off the ultrasound system while the system is exporting.
- Do not bump or otherwise apply pressure to the USB storage device while it is in a USB port on the ultrasound system. The connector could break.

Caution: If the internal storage icon does not appear in the system status area, internal storage may be defective. Contact SonoSite Technical Support. (See [“SonoSite Technical Support”](#) on page viii.)

The patient list lets you organize saved images and clips from a central location. You can delete, view, print, or archive them. You can also copy them to a USB storage device.

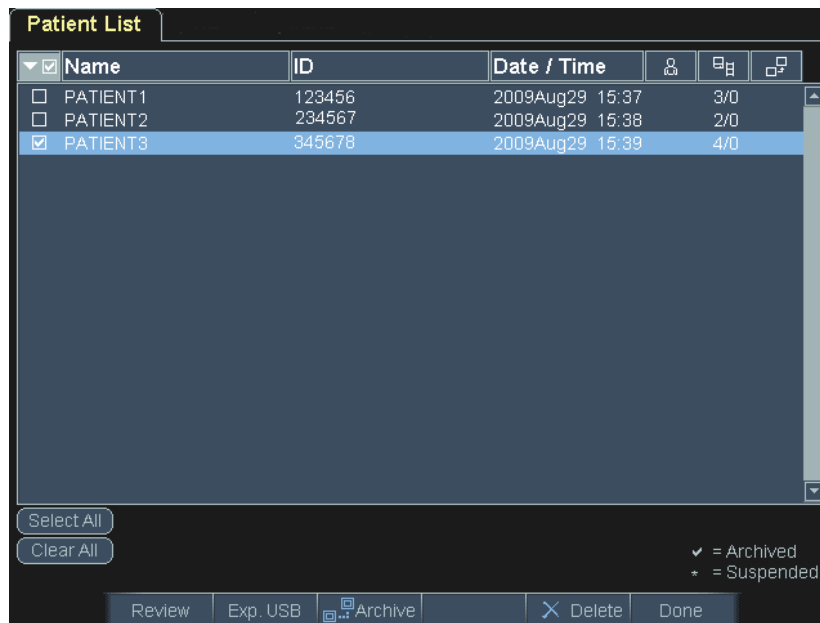

Figure 1 Patient List

To open the patient list

- 1 Press the REVIEW key.
- 2 If there is a current patient, select **List** on-screen.

To sort the patient list

After the system starts, the patient list is arranged by date and time, with the most recent patient file first. You can re-sort the patient list as needed.

- ❖ Select the column heading that you want to sort by. Select it again if sorting in reverse order.

Note: The column heading is selectable.

To select patients in the patient list

- ❖ Using the touchpad, select the check box for one or more patients.

Select All selects all patients.

To deselect patients, select checked boxes or **Clear All**.

To review images and clips

You can review only one patient's images and clips at a time.

- 1 In the patient list, highlight the patient whose images and clips you want to review.
- 2 Select **Review** on-screen.
- 3 Select **x/x** to cycle to the image or clip you want to review.
- 4 (Clip Only) Select **Play**.

The clip plays automatically after loading. The load time depends on clip length.

You can select **Pause** to freeze the clip and can select a playback speed **1x**, **1/2x**, **1/4x**.

- 5 Select **x/x** to cycle to the next image or clip you want to view.

To return to the patient list, select **List**. To return to imaging, select **Done**.

To print an image

- 1 Verify that a printer is selected. See ["To configure the system for a printer"](#) on page 24.
- 2 Do one of the following:

- In the patient list, review the patient's images. Select **Print** when the image appears.
- With the image displayed, press the A shortcut key.

By default, the A shortcut key prints. To reprogram the A and B shortcut keys, see ["To set presets"](#) on page 29.

To print multiple images

- 1 Verify that a printer is selected. See ["To configure the system for a printer"](#) on page 24.
- 2 Do one of the following:

- Print all images for multiple patients: Select one or more patients in the patient list. Then select **Print**.
- Print all images for one patient: Highlight the patient in the patient list, and then select **Print**.

Each image appears briefly on-screen while printing.

To export images or clips to a USB storage device

A USB storage device is for temporary storage of images and clips. Patient exams should be archived regularly. To specify file format, see “[USB Devices setup](#)” on page 30.

- 1 Insert the USB storage device.
- 2 In the patient list, select the patients whose images and clips you want to export.
- 3 Select **Exp. USB** on-screen. A list of USB devices appears.
- 4 Select the USB storage device, and select **Export**.

Only available USB devices (for example, not password-protected) are selectable.

The files are finished exporting approximately five seconds after the USB animation stops. Removing the USB storage device or turning off the system while exporting may cause exported files to be corrupted or incomplete. To stop in-progress exporting, select **Cancel Export**.

To delete images and clips

- 1 Select one or more patients in the patient list.
- 2 Select **Delete** to delete the selected patients. A confirmation screen appears.

To archive images and clips

You can send patient exams to a DICOM printer or archiver, or to a PC using SiteLink. DICOM and SiteLink are optional features.

- 1 Select one or more patients in the patient list.
- 2 Select **Archive**.

ECG Monitoring

ECG Monitoring is an optional feature and requires a SonoSite ECG cable.

WARNING: To prevent misdiagnosis, do not use the ECG trace to diagnose cardiac rhythms. The SonoSite ECG option is a non-diagnostic feature.

To avoid electrical interference with aircraft systems, do not use the ECG cable on aircraft. Such interference may have safety consequences.

Caution: Use only accessories recommended by SonoSite with the system. Your system can be damaged by connecting an accessory not recommended by SonoSite.

To monitor ECG





- 1 Connect the ECG cable to the ECG connector on the ultrasound system, mini-dock, or docking system.

ECG Monitoring turns on automatically.

Note: An external ECG monitor may cause a lag in the timing of the ECG trace, corresponding with the 2D image. Biopsy guidelines are not available when ECG is connected.

- 2 Select **ECG** on-screen. (**ECG** may be on another page. It appears only if the ECG cable is connected.)
- 3 Select options as desired.

ECG Monitoring options

Option	Icon	Description
Show/Hide		Turns on and off ECG trace.
Gain		Increases or decreases ECG gain. Settings are 0-20 .
Position		Sets the position of the ECG trace.
Sweep Speed		Settings are Slow, Med, and Fast .
Delay		Displays Line and Save for clip acquisition delay. (For instructions to capture clips, see "To capture and save a clip" on page 48.)
Line		The position of the delay line on the ECG trace. The delay line indicates where the clip acquisition is triggered.
Save		Saves the current position of the delay line on the ECG trace. (You can change the position of the delay line temporarily. Starting a new patient information form or cycling system power reverts the delay line to the most recently saved position.) Select Delay to display these options.

Chapter 4: Measurements and Calculations

You can measure for quick reference, or you can measure within a calculation. You can perform general calculations as well as calculations specific to an exam type.

Measurements are performed on frozen images. For references used, see [Chapter 7, "References."](#)

Measurements

You can perform basic measurements in any imaging mode and can save the image with the measurements displayed. (See ["To save an image"](#) on page 48.) Except for the M Mode HR measurement, the results do not automatically save to a calculation and the patient report. If you prefer, you can first begin a calculation and then measure. See ["Performing and saving measurements in calculations"](#) on page 62.

Some options may not apply to your system. Options available depend on your configuration, transducer, and exam type.

To save a measurement to a calculation and patient report

- 1 With the measurement active (green), press the CALCS key.
- 2 From the calculations menu, select a measurement name.

Only measurement names available for the imaging mode and exam type are selectable.

- 3 Save the calculation. (See ["To save a calculation"](#) on page 62.)

To start a calculation before measuring, see ["Performing and saving measurements in calculations"](#) on page 62.

Working with calipers

When measuring, you work with calipers, often in pairs. Results based on the calipers' position appear at the bottom of the screen. The results update as you reposition the calipers by using the touchpad. In trace measurements, the results appear after you complete the trace.

Outside a calculation, you can add calipers by pressing the CALIPER key. You can have multiple sets of calipers and can switch from one set to another, repositioning them as needed. Each set shows the measurement result. The active calipers and measurement result are highlighted green. A measurement is complete when you finish moving its calipers.

Within a calculation, calipers appear when you select from the calculations menu. (See ["To select from the calculations menu"](#) on page 61.)

For an accurate measurement, accurate placement of calipers is essential.

To switch the active calipers

- ❖ Do one of the following:
 - To switch the active caliper within a set, press the SELECT key.
 - To switch the active set when measuring outside a calculation, select **Switch** on-screen.

To delete or edit a measurement

- ❖ With the measurement active (highlighted), do one of the following:
 - To delete, select **Delete** on-screen.
 - To edit, use the touchpad to move the calipers.

Note: Trace measurements cannot be edited once set.

To improve precision of caliper placement

- ❖ Do any of the following:
 - Adjust the display for maximum sharpness.
 - Use leading edges (closest to the transducer) or borders for starting and stopping points.
 - Maintain a consistent transducer orientation for each type of measurement.
 - Make sure that the area of interest fills as much of the screen as possible.
 - (2D) Minimize the depth, or zoom.

2D measurements

The basic measurements that you can perform in 2D imaging are as follows:

- Distance in cm
- Area in cm²
- Circumference in cm

You can also measure area or circumference by manually tracing.

You can perform a combination of distance, area, circumference, and manual trace measurements at one time. The total number possible depends on their order and type.

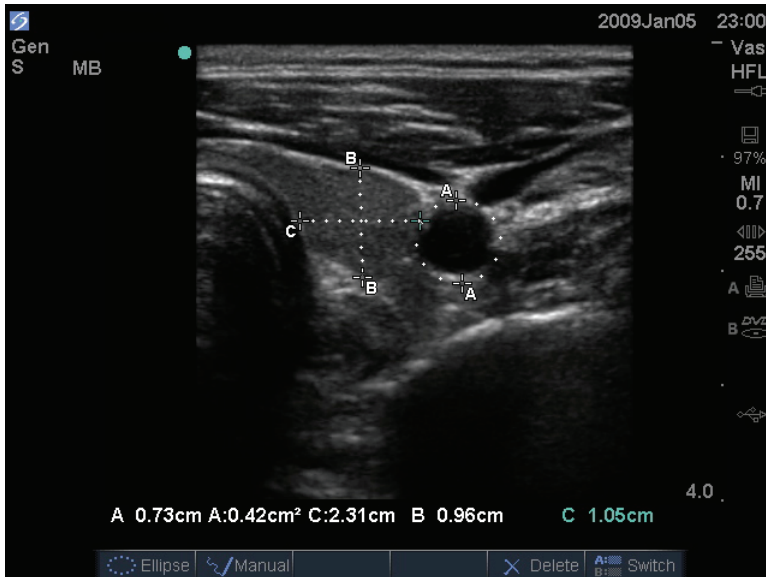

Figure 1 2D image with two distance and one circumference measurement

To measure distance (2D)

You can perform up to eight distance measurements on a 2D image.

- 1 On a frozen 2D image, press the CALIPER key.
A pair of calipers appears, connected by a dotted line.
- 2 Using the touchpad, position the first caliper, and then press the SELECT key.
The other caliper becomes active.
- 3 Using the touchpad, position the other caliper.

If you move the calipers close together, they shrink and the dotted line disappears.

See [“To save a measurement to a calculation and patient report”](#) on page 55.

To measure area or circumference (2D)

- 1 On a frozen 2D image, press the CALIPER key.
- 2 Select **Ellipse** on-screen.
Note: If you exceed the allowed number of measurements, Ellipse is not available.
- 3 Use the touchpad to adjust the size and position of the ellipse. The SELECT key toggles between position and size.

See [“To save a measurement to a calculation and patient report”](#) on page 55.

To trace manually (2D)

1 On a frozen 2D image, press the CALIPER key.

2 Select **Manual** on-screen.

Note: If you exceed the allowed number of measurements, Manual is not available.

3 Using the touchpad, position the caliper where you want to begin.

4 Press the SELECT key.

5 Using the touchpad, complete the trace, and press the SET key.

See [“To save a measurement to a calculation and patient report”](#) on page 55.

M Mode measurements

The basic measurements that you can perform in M Mode imaging are as follows:

- Distance in cm/Time in seconds
- Heart Rate (HR) in beats per minute (bpm)

The time scale above the trace has small marks at 200 ms intervals and large marks at one-second intervals.

To measure distance (M Mode)

You can perform up to four distance measurements on an image.

1 On a frozen M Mode trace, press the CALIPER key.

A single caliper appears.

2 Using the touchpad, position the caliper.

3 Press the SELECT key to display the second caliper.

4 Using the touchpad, position the second caliper.

See [“To save a measurement to a calculation and patient report”](#) on page 55.

To measure heart rate (M Mode)

1 On a frozen M Mode trace, press the CALIPER key.

2 Select **HR** on-screen.

A vertical caliper appears.

3 Using the touchpad, position the vertical caliper at the peak of the heartbeat.

4 Press the SELECT key.

A second vertical caliper appears.

5 Using the touchpad, position the second vertical caliper at the peak of the next heartbeat.

See “To save a measurement to a calculation and patient report” on page 55. Saving the heart rate measurement to the patient report overwrites any heart rate entered on the patient information form.

See also “To measure fetal heart rate (M Mode)” on page 88.

Doppler measurements

The basic measurements that you can perform in Doppler imaging are Velocity (cm/s), Pressure Gradient, Elapsed Time, +/x Ratio, Resistive Index (RI), and Acceleration. You can also trace manually or automatically.

For Doppler measurements, the Doppler scale must be set to cm/s. See “Presets setup” on page 29.

To measure Velocity (cm/s) and Pressure Gradient (Doppler)

1 On a frozen Doppler spectral trace, press the CALIPER key.

A single caliper appears.

2 Using the touchpad, position the caliper to a peak velocity waveform.

This measurement involves a single caliper from the baseline.

See “To save a measurement to a calculation and patient report” on page 55.

To measure Velocities, Elapsed Time, +/x Ratio, Resistive Index (RI), and Acceleration (Doppler)

1 On a frozen Doppler spectral trace, press the CALIPER key.

A single caliper appears.

2 Using the touchpad, position the caliper to a peak systolic waveform.

3 Press the SELECT key.

A second caliper appears.

4 Using the touchpad, position the second caliper at the end diastole on the waveform.

See “To save a measurement to a calculation and patient report” on page 55.

To trace manually (Doppler)

1 On a frozen Doppler spectral trace, press the CALIPER key.

2 Select **Manual** on-screen.

A single caliper appears.

3 Using the touchpad, position the caliper at the beginning of the desired waveform, and press the SELECT key.

If calipers are not positioned correctly, the result is inaccurate.

- 4 Using the touchpad, trace the waveform.

To make a correction, select **Undo** on-screen, backtrack with the touchpad, or press the BACKSPACE key.

- 5 Press the SET key.

The measurement results appear.

See [“To save a measurement to a calculation and patient report”](#) on page 55.

To trace automatically (Doppler)

After tracing automatically, confirm that the system-generated boundary is correct. If you are not satisfied with the trace, obtain a high-quality Doppler spectral trace image, or trace manually. (See [“To trace manually \(Doppler\)”](#) on page 59.)

- 1 On a frozen Doppler spectral trace, press the CALIPER key.

- 2 Select **Auto** on-screen.

A vertical caliper appears.

- 3 Using the touchpad, position the caliper at the beginning of the waveform.

If calipers are not positioned correctly, the calculation result is inaccurate.

- 4 Press the SELECT key.

A second vertical caliper appears.

- 5 Using the touchpad, position the second caliper at the end of the waveform.

- 6 Press the SET key.

The measurement results appear.

See [“To save a measurement to a calculation and patient report”](#) on page 55.

Automatic Trace Measurement Results for Exam Type (Doppler)

Automatic Trace Results	Exam Type				
	Abdomen	Cardiac	Neo	OB/Gyn	Vascular
Velocity Time Integral (VTI)	—	X	—	—	—
Peak Velocity (Vmax)	X	X	—	X	X
Mean Pressure Gradient (PGmean)	—	X	—	—	—
Mean Velocity on Peak Trace (Vmean)	—	X	—	—	—
Pressure Gradient (PGmax)	—	X	—	—	—

Automatic Trace Measurement Results for Exam Type (Doppler) (Continued)

Automatic Trace Results	Exam Type				
	Abdomen	Cardiac	Neo	OB/Gyn	Vascular
Cardiac Output (CO)	—	X	—	—	—
Peak Systolic Velocity (PSV)	—	—	X	—	—
Time Average Mean (TAM)*	—	—	X	—	—
+/- or Systolic/Diastolic (S/D)	X	—	X	X	X
Pulsatility Index (PI)	X	—	X	X	X
End Diastolic Velocity (EDV)	X	—	X	X	X
Acceleration Time (AT)	X	—	—	—	—
Resistive Index (RI)	X	—	X	X	X
Time Average Peak (TAP)	—	—	X	—	—
Gate Depth	—	—	X	—	—

* The automatic trace tool must be used to calculate the TAM.

General calculations

Within calculations, you can save measurement results to the patient report. You can view, repeat, and delete measurements from a calculation. Some measurements can be deleted directly from the patient report pages. See [“Patient report” on page 92](#).

Calculation packages depend on exam type and transducer.

Calculations menu

The calculations menu contains measurements available for the imaging mode and exam type. After you perform and save a measurement, the result saves to the patient report. (See [“Patient report” on page 92](#).) Also, a check mark appears next to the measurement name in the calculations menu. If you highlight the checked measurement name, the results appear below the menu. If you repeat the measurement, the results below the menu reflect either the last measurement or the average, depending on the measurement.

Menu items followed by ellipses (. . .) have subentries.

To select from the calculations menu

- 1 On a frozen image, press the CALCS key.

The calculations menu appears.

2 Using the touchpad or arrow keys, highlight the desired measurement name.

To display additional measurement names, highlight **Next**, **Prev**, or a measurement name that has ellipses (. . .). Then press the SELECT key.

Only measurement names available for the imaging mode are selectable.

3 Press the SELECT key.

To close the calculations menu, press the CALCS key once (if the menu is active) or twice (if the menu is inactive).

Performing and saving measurements in calculations

In performing a measurement within a calculation, you select from the calculations menu, position the calipers that appear, and then save the calculation. Unlike measurements performed outside a calculation, the calipers appear by selecting from the calculations menu, not by pressing the CALIPER key. The type of calipers that appear depends on the measurement.

To save a calculation

❖ Do one of the following:

- Save the calculation only: Press the SAVE CALC key, or select **Save** on-screen.

The calculation saves to the patient report. To save the image with the measurements displayed, see [“To save an image”](#) on page 48.

- Save both the image and calculation: Press the SAVE key if the SAVE key functionality is set to **Image/Calcs**. (See [“To set presets”](#) on page 29.)

The calculation saves to the patient report, and the image saves to internal storage with the measurements displayed.

Viewing, repeating, and deleting saved measurements in calculations

To view a saved measurement

❖ Do one of the following:

- Highlight the measurement name in the calculations menu. The result appears below the menu.
- Open the patient report. See [“Patient report”](#) on page 92.

To repeat a saved measurement

1 Highlight the measurement name in the calculations menu.

2 Press the SELECT key or the CALIPER key.

- 3 Perform the measurement again.

The new results appear on-screen in the measurement and calculations data area. (See “[Screen layout](#)” on page 12.) You can compare them to the saved results below the menu.

- 4 To save the new measurement, press the SAVE CALC key.

The new measurement saves to the patient report and overwrites the previously saved measurement.

To delete a saved measurement

- 1 Select the measurement name from the calculations menu.

- 2 Select **Delete** on-screen.

The measurement last saved is deleted from the patient report. If it is the only measurement, the check mark is deleted from the calculations menu.

Some measurements can be deleted directly from the report pages. See “[Patient report](#)” on page 92.

Percent reduction calculations

WARNING: To avoid incorrect calculations, verify that the patient information, date, and time settings are accurate.

To avoid misdiagnosis or harming the patient outcome, start a new patient information form before starting a new patient exam and performing calculations. Starting a new patient information form clears the previous patient’s data. The previous patient’s data will be combined with the current patient if the form is not first cleared. See “[To create a new patient information form](#)” on page 45

Transducers and Exam Types for Percent Reduction Calculations

Transducer	Exam Types
C11x	Abdomen
C60x	Abdomen
HFL38x	IMT, Small Parts, Vascular
L25x	Vascular, Muscle
L38x	IMT, Small Parts, Vascular
P21x	Abdomen

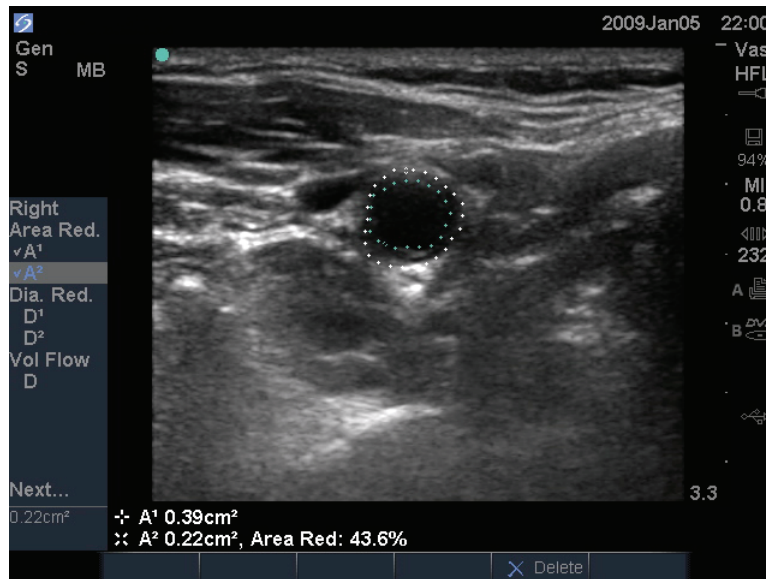

Figure 2 Percent area reduction calculation of right carotid bulb

To calculate percent area reduction

The percent area reduction calculation involves two manual trace measurements.

- 1 On a frozen 2D image, press the CALCS key.
- 2 Do the following for **A¹** and then for **A²**:
 - a From the calculations menu, select the measurement name under **Area Red.**
 - b Using the touchpad, move the caliper to the trace starting point, and press the SELECT key.
 - c Using the touchpad, trace the desired area.
To make a correction, select **Undo** on-screen or press the BACKSPACE key.
 - d Complete the trace, and press the SET key.
 - e Save the calculation. See [“To save a calculation”](#) on page 62.

The percent area reduction result appears on-screen in the measurement and calculation data area and in the patient report.

To calculate percent diameter reduction

- 1 On a frozen 2D image, press the CALCS key.
- 2 Do the following for **D¹** and then for **D²**:
 - a From the calculations menu, select the measurement name under **Dia Red.**
 - b Position the calipers. (See [“Working with calipers”](#) on page 55.)

- c Save the calculation. See [“To save a calculation”](#) on page 62.

The percent diameter reduction result appears in the measurement and calculation data area and in the patient report.

Volume calculations

WARNING: To avoid incorrect calculations, verify that the patient information, date, and time settings are accurate.

To avoid misdiagnosis or harming the patient outcome, start a new patient information form before starting a new patient exam and performing calculations. Starting a new patient information form clears the previous patient’s data. The previous patient’s data will be combined with the current patient if the form is not first cleared. See [“To create a new patient information form”](#) on page 45

Transducers and Exam Types for Volume Calculations

Transducer	Exam Types
C11x	Abdomen, Nerve
C60x	Gyn, Abdomen
HFL38x	Breast, Nerve, Small Parts, Vascular
ICTx	Gyn
L25x	Nerve, Vascular, Superficial, Muscle
L38x	Breast, Nerve, Small Parts, Vascular
P21x	Abdomen

To calculate volume

The volume calculation involves three 2D distance measurements: D^1 , D^2 , and D^3 . After all measurements are saved, the result appears on-screen and in the patient report.

- ❖ Do the following for each image you need to measure:
 - a On the frozen 2D image, press the CALCS key.
 - b Do the following for each measurement you need to take:
 - i From the calculations menu, select the measurement name under **Volume**.
 - ii Position the calipers. (See [“Working with calipers”](#) on page 55.)
 - iii Save the measurement. See [“To save a calculation”](#) on page 62.

Volume flow calculations

WARNING: To avoid incorrect calculations, verify that the patient information, date, and time settings are accurate.

To avoid misdiagnosis or harming the patient outcome, start a new patient information form before starting a new patient exam and performing calculations. Starting a new patient information form clears the previous patient's data. The previous patient's data will be combined with the current patient if the form is not first cleared. See ["To create a new patient information form"](#) on page 45.

Transducers and Exam Types for Volume Flow Calculations

Transducer	Exam Types
C11x	Abdomen
C60x	Abdomen
HFL38x	Vascular
L25x	Vascular
L38x	Vascular
P21x	Abdomen

The following table shows the measurements required to complete the volume flow calculation. For definitions of acronyms, see ["Glossary"](#) on page 179.

Volume Flow Calculation

Menu Heading	Measurement (Imaging Mode)	Calculation Result
Vol Flow	D (2D) TAM (Doppler)	VF (Volume Flow 1/min)

Both a 2D and a Doppler measurement are required for the volume flow calculation. The Doppler sample volume should completely insonate the vessel.

Consider the following factors when performing volume flow measurements:

- Users should follow current medical practice for volume flow calculation applications.
- The accuracy of the volume flow calculation largely depends on the user.
- The factors identified in the literature that affect the accuracy are as follows:
 - Using the diameter method for 2D area

- Difficulty ensuring uniform insonation of the vessel.
The system is limited to the following sample volume sizes:
 - C11x transducer: 1, 2, 3 Gate Size (mm)
 - C60x transducer: 2, 3, 5, 7, 10, 12 Gate Size (mm)
 - HFL38x, L25x, and L38x transducers: 1, 3, 5, 7, 10, 12 Gate Size (mm)
 - P21x transducer: 2, 3, 5, 7, 11.5, 14 Gate Size (mm)
- Precision in placing the caliper
- Accuracy in angle correction

The considerations and degree of accuracy for volume flow measurements and calculations are discussed in the following reference:

Allan, Paul L. et al. *Clinical Doppler Ultrasound*, 4th Ed., Harcourt Publishers Limited, (2000) 36-38.

To calculate volume flow

1 Perform the 2D measurement:

- On a frozen full-screen 2D image or duplex image, press the CALCS key.
- From the calculations menu, select **D** (distance) under **Vol Flow**.
- Position the calipers. (See “[Working with calipers](#)” on page 55.)
- Save the calculation. See “[To save a calculation](#)” on page 62.

2 Perform the Doppler measurement:

- On a frozen Doppler spectral trace, press the CALCS key.
- From the calculations menu, select **TAM** under **Vol Flow**.
- Press the SELECT key to display a vertical caliper.
- Using the touchpad, position the vertical caliper at the beginning of the waveform.
If calipers are not positioned correctly, the calculation result is inaccurate.
- Press the SELECT key to display a second vertical caliper.
- Using the touchpad, position the second vertical caliper at the end of the waveform.
- Press the SET key to complete the trace and to display the results.
- Save the calculation. See “[To save a calculation](#)” on page 62.

To view the volume flow calculation, see “[Patient report](#)” on page 92.

Specialized calculations

In addition to the general calculations, there are calculations specific to the Cardiac, Gynecology (Gyn), IMT, OB, Small Parts, and Vascular exam types.

Cardiac calculations

WARNING: To avoid incorrect calculations, verify that the patient information, date, and time settings are accurate.

To avoid misdiagnosis or harming the patient outcome, start a new patient information form before starting a new patient exam and performing calculations. Starting a new patient information form clears the previous patient's data. The previous patient's data will be combined with the current patient if the form is not first cleared. See ["To create a new patient information form"](#) on page 45.

Transducers and Exam Type for Cardiac Calculations

Transducer	Exam Type
P21x	Cardiac

The following table shows the measurements required to complete different cardiac calculations. For definitions of acronyms, see ["Glossary"](#) on page 179.

Cardiac Calculations

Menu Heading	Cardiac Measurements (Imaging Mode)	Calculation Results
LVd	RVW (2D)	CO
	RVD (2D)	EF
	IVS (2D)	SV
	LVD (2D)	LVESV
	LVPW (2D)	LVEDV
	IVSFT	
LVs	RVW (2D)	LVPWFT
	RVD (2D)	LVDfs
	IVS (2D)	CI
	LVD (2D)	SI
	LVPW (2D)	
	HR ^a needed for CO & CI	

Cardiac Calculations (Continued)

Menu Heading	Cardiac Measurements (Imaging Mode)	Calculation Results
LV	Ao (2D or M Mode)	Ao LA/Ao
	AAo (2D)	AAo
	LA (2D or M Mode)	LA LA/Ao
	LVOT D (2D)	LVOT D LVOT area
	ACS (M Mode)	ACS
	LVET (M Mode)	LVET
	EF:Slope (M Mode)	EF SLOPE
	EPSS (M Mode)	EPSS
LVd	RVW (M Mode)	CO
	RVD (M Mode)	EF
	IVS (M Mode)	SV
	LVD (M Mode)	LVESV
	LVPW (M Mode)	LVEDV
LVs	RVW (M Mode)	IVSFT
	RVD (M Mode)	LVPWFT
	IVS (M Mode)	LVDFS
	LVD (M Mode)	CI
	LVPW (M Mode)	SI
HR	HR ^a	LV Mass
Area	AV (2D)	AV Area
	MV (2D)	MV Area

Cardiac Calculations (Continued)

Menu Heading	Cardiac Measurements (Imaging Mode)	Calculation Results
LV Vol	A4Cd (2D)	LV Vol
	A4Cs (2D)	LV Area
	A2Cd (2D)	EF
	A2Cs (2D)	CO
		SV
		CI
		SI
		Biplane
LV mass	Epi (2D)	LV Mass
	Endo (2D)	Epi Area
	Apical (2D)	Endo Area
		D Apical
PISA	Ann D (2D)	PISA Area
	Radius (Color)	ERO
	MR/VTI (Doppler)	MV Rate
	MV/VTI (Doppler)	Regurgitant Volume
		Regurgitant Fraction
Qp/Qs	LVOT D (2D)	D
	RVOT D (2D)	VTI
	LVOT VTI (Doppler)	VMax
	RVOT VTI (Doppler)	PGmax
		Vmean
		PGmean
		SV
	Qp/Qs	

Cardiac Calculations (Continued)

Menu Heading	Cardiac Measurements (Imaging Mode)	Calculation Results
MV	E (Doppler)	E
	A (Doppler)	E PG A A PG E:A
	PHT (deceleration time) (Doppler)	PHT MVA Decel time
	VTI (Doppler)	VTI Vmax PGmax Vmean PGmean
	IVRT (Doppler)	IVRT
MV >MR	dP:dT ^b (CW Doppler)	dP:dT
AV	Vmax (Doppler)	Vmax PGmax
	VTI (Doppler)	VTI Vmax PGmax Vmean PGmean
	VTI or Vmax from LVOT (Doppler) VTI or Vmax from AV (Doppler)	AVA
	LV	LVOT D (2D)
AV	VTI (Doppler)	SV
LV	LVOT D (2D)	

Cardiac Calculations (Continued)

Menu Heading	Cardiac Measurements (Imaging Mode)	Calculation Results
AV	VTI (Doppler)	CO
LV	LVOT D (2D)	
HR	HR ^a	
LVOT	Vmax (Doppler)	Vmax PGmax
	VTI (Doppler)	VTI Vmax PGmax Vmean PGmean
AV > AI	PHT (slope) (Doppler)	AI PHT AI slope
TV	TRmax (Doppler)	Vmax PGmax
	RA pressure ^c	RVSP
PV	Vmax (Doppler)	Vmax PGmax
	VTI (Doppler)	VTI Vmax PGmax Vmean PGmean

a. You can enter the HR measurement three ways: Patient information form, Doppler measurement (See [“To calculate Heart Rate \(HR\)”](#) on page 78), or M Mode measurement (See [“To measure heart rate \(M Mode\)”](#) on page 58).

b. Performed at 100 cm/s and 300 cm/s.

c. Specified on the cardiac report. See [“To view a vascular or cardiac report”](#) on page 92.

To measure LVd and LVs

- 1 On a frozen 2D image or M Mode trace, press the CALCS key.
- 2 From the calculations menu, select the measurement name.

3 Position the active (green) caliper at the starting point. (See “Working with calipers” on page 55.)

4 Press the SELECT key, and position the second caliper.

5 Press the SELECT key.

Another caliper appears, and the calculations menu highlights the next measurement name.

6 Position the caliper, and press the SELECT key. Repeat for each measurement name in the calculation group.

Each time you press the SELECT key, another caliper appears, and the calculations menu highlights the next measurement name.

7 Save the calculation. (See “To save a calculation” on page 62.)

To measure Ao, LA, AAO, or LVOT D

1 On a frozen 2D image or M Mode trace, press the CALCS key.

2 From the calculations menu, select the measurement name.

3 Position the calipers. (See “Working with calipers” on page 55.)

4 Save the calculation. (See “To save a calculation” on page 62.)

To calculate LV Volume (Simpson’s Rule)

1 On a frozen 2D image, press the CALCS key.

2 Do the following for each measurement:

a From the calculations menu, select the desired view and phase.

b Position the caliper at the mitral annulus, and press the SELECT key to start the trace.

c Using the touchpad, trace the left ventricular (LV) cavity.

To make a correction, select **Undo** on-screen or press the BACKSPACE key.

d Complete the trace, and press the SET key.

e Save the calculation. (See “To save a calculation” on page 62.)

To calculate MV or AV area

1 On a frozen 2D image, press the CALCS key.

2 In the calculations menu, locate **Area**, and then select **MV** or **AV**.

3 Position the caliper where you want to begin the trace, and press the SELECT key.

4 Using the touchpad, trace the desired area.

To make a correction, select **Undo** on-screen or press the BACKSPACE key.

5 Complete the trace, and press the SET key.

6 Save the calculation. (See “To save a calculation” on page 62.)

To calculate LV Mass

- 1 On a frozen 2D image, press the CALCS key.
- 2 In the calculations menu, locate **LV Mass**.
- 3 Do the following for **EPI** and then for **Endo**:
 - a Select the measurement name from the calculations menu.
 - b Position the caliper where you want to begin the trace, and press the SELECT key.
 - c Using the touchpad, trace the desired area.

To make a correction, select **Undo** on-screen or press the BACKSPACE key.
 - d Complete the trace, and press the SET key.
 - e Save the calculation. (See “To save a calculation” on page 62.)
- 4 Select **Apical** from the calculations menu.
- 5 Positioning the calipers, measure the ventricular length. (See “Working with calipers” on page 55.)
- 6 Save the calculation.

To perform peak velocity measurements in the calculation package

For each cardiac measurement, the system saves up to five individual measurements and calculates their average. If you take more than five measurements, the most recent measurement replaces the fifth one. If you delete a saved measurement from the report, the next measurement taken replaces the deleted one in the report. The most recently saved measurement appears at the bottom of the calculations menu.

- 1 On a frozen Doppler spectral trace, press the CALCS key.
- 2 From the calculations menu, select **MV**, **TV**, or **TDI**.
- 3 Do the following for each measurement you want to take:
 - a Select the measurement name from the calculations menu.
 - b Position the calipers. (See “Working with calipers” on page 55.)
 - c Save the calculation. (See “To save a calculation” on page 62.)

To calculate Velocity Time Integral (VTI)

Note: This calculation computes other results in addition to VTI. See the table “Cardiac Calculations” on page 68.

- 1 On a frozen Doppler spectral trace, press the CALCS key.
- 2 From the calculations menu, select **MV**, **AV**, **PV**, or **LVOT** and then select **VTI**.
- 3 Position the caliper at the start of the waveform, and press the SELECT key to start the trace.

- 4 Using the touchpad, trace the waveform.

To make a correction, select **Undo** on-screen, backtrack with the touchpad, or press the BACKSPACE key.

- 5 Press the SET key to complete the trace.
- 6 Save the calculation. (See “To save a calculation” on page 62.)

For information on the automatic trace tool, see “To trace automatically (Doppler)” on page 60.

To calculate Right Ventricular Systolic Pressure (RVSP)

- 1 On a frozen Doppler spectral trace, press the CALCS key.
- 2 From the calculations menu, select **TV** and then select **TRmax**.
- 3 Position the caliper. (See “Working with calipers” on page 55.)
- 4 Save the calculation. (See “To save a calculation” on page 62.)
- 5 To adjust the RA pressure, see “To view a vascular or cardiac report” on page 92.

Changing the RA pressure from the default 5 affects the RVSP calculation in the report.

To calculate Pressure Half Time (PHT) in MV or AV

- 1 On a frozen Doppler spectral trace, press the CALCS key.
- 2 From the calculations menu, select **MV** or **AV**, and then select **PHT**.
- 3 Position the first caliper at the peak, and press the SELECT key.
A second caliper appears.
- 4 Position the second caliper:
 - In MV, position the caliper along the EF slope.
 - In AV, position the caliper at the end diastole.
- 5 Save the calculation. (See “To save a calculation” on page 62.)

To calculate Proximal Isovelocity Surface Area (PISA)

The PISA calculation requires a measurement in 2D, a measurement in Color, and two measurements in Doppler spectral trace. After all measurements are saved, the result appears in the patient report.

- 1 Measure from Ann D (2D):
 - a On a frozen 2D image, press the CALCS key.
 - b From the calculations menu, locate **PISA**, and then select **Ann D**.
 - c Position the calipers. (See “Working with calipers” on page 55.)
 - d Save the calculation. (See “To save a calculation” on page 62.)

2 Measure from Radius (Color):

- a** On a frozen Color image, press the CALCS key.
- b** From the calculations menu, select **Radius**.
- c** Position the calipers.
- d** Save the calculation.

3 On a frozen Doppler spectral trace, press the CALCS key.

4 Do the following to measure from MR VTI and again to measure from MV VTI (Doppler):

- a** From the calculations menu, select **PISA** and then select **MR VTI** or **MV VTI**.
- b** Position the caliper at the start of the waveform, and press the SELECT key to start the trace.
- c** Using the touchpad, trace the waveform.
To make a correction, select **Undo** on-screen, backtrack with the touchpad, or press the BACKSPACE key.
- d** Press the SET key to complete the trace.
- e** Save the calculation.

For information on the automatic trace tool, see [“To trace automatically \(Doppler\)”](#) on page 60.

To calculate Isovolumic Relaxation Time (IVRT)

- 1** On a frozen Doppler spectral trace, press the CALCS key.
- 2** From the calculations menu, select **MV** and then select **IVRT**.
A vertical caliper appears.
- 3** Using the touchpad, position the caliper at the aortic valve closure.
- 4** Press the SELECT key.
A second vertical caliper appears.
- 5** Using the touchpad, position the second caliper at onset of mitral inflow.
- 6** Save the calculation. (See [“To save a calculation”](#) on page 62.)

To calculate Delta Pressure: Delta Time (dP:dT)

To perform the dP:dT measurements, the CW Doppler scale must include velocities of 300 cm/s or greater on the negative side of the baseline. (See [“Spectral trace options”](#) on page 41.)

- 1** On a frozen CW Doppler spectral trace, press the CALCS key.
- 2** From the calculations menu, select **MV**, and then select **dP:dT**.
A horizontal dotted line with an active caliper appears at 100 cm/s.
- 3** Position the first caliper along the waveform at 100 cm/s.

- 4 Press the SELECT key.

A second horizontal dotted line with an active caliper appears at 300 cm/s.

- 5 Position the second caliper along the waveform at 300 cm/s.
- 6 Save the calculation. (See “To save a calculation” on page 62.)

To calculate Aortic Valve Area (AVA)

The AVA calculation requires a measurement in 2D and two measurements in Doppler. After the measurements are saved, the result appears in the patient report.

- 1 Measure from LVOT (2D):

- a On a frozen 2D image, press the CALCS key.
- b From the calculations menu, select **LVOT D**.
- c Position the calipers. (See “Working with calipers” on page 55.)
- d Save the calculation. (See “To save a calculation” on page 62.)

- 2 Measure from LVOT, and then measure from AV (Doppler):

- For Vmax, see “To perform peak velocity measurements in the calculation package” on page 74. From the calculations menu, select **AV**, select sample site, and then select **Vmax**.
- For VTI, see “To calculate Velocity Time Integral (VTI)” on page 74. From the calculations menu, select **AV**, select sample site, and then select **VTI**.

To calculate Qp/Qs

The Qp/Qs calculation requires two measurements in 2D and two measurements in Doppler. After the measurements are saved, the result appears in the patient report.

- 1 On a frozen 2D image, press the CALCS key.
- 2 Do the following to measure from LVOT D and again to measure from RVOT D:
 - a From the calculations menu, locate **Qp/Qs** and then select **LVOT D** or **RVOT D**.
 - b Position the calipers. (See “Working with calipers” on page 55.)
 - c Save the calculation. (See “To save a calculation” on page 62.)
- 3 On a frozen Doppler spectral trace, press the CALCS key.
- 4 Do the following to measure from LVOT VTI and again to measure from RVOT VTI:
 - a From the calculations menu, select **Qp/Qs** and then select **LVOT VTI** or **RVOT VTI**.
 - b Press the SELECT key to start the trace.
 - c Using the touchpad, trace the waveform.

To make a correction, select **Undo** on-screen, backtrack with the touchpad, or press the BACKSPACE key.
 - d Press the SET key to complete the trace.

- e Save the calculation. (See [“To save a calculation”](#) on page 62.)

For information on the automatic trace tool, see [“To trace automatically \(Doppler\)”](#) on page 60.

To calculate Stroke Volume (SV) or Stroke Index (SI)

The SV and SI calculations require a measurement in 2D and a measurement in Doppler. SI also requires Body Surface Area (BSA). After the measurements are saved, the result appears in the patient report.

- 1 (SI Only) Fill in the **Height** and **Weight** fields on the patient information form. The BSA is calculated automatically. (See [“To create a new patient information form”](#) on page 45.)
- 2 Measure from LVOT (2D):
 - a On a frozen 2D image, press the CALCS key.
 - b From the calculations menu, select **LVOT D**.
 - c Position the calipers. (See [“Working with calipers”](#) on page 55.)
 - d Save the calculation. (See [“To save a calculation”](#) on page 62.)
- 3 Measure from aorta (Doppler). See [“To calculate Velocity Time Integral \(VTI\)”](#) on page 74. From the calculations menu, select **AV** and then select **VTI**.

For information on the automatic trace tool, see [“To trace automatically \(Doppler\)”](#) on page 60.

To calculate Heart Rate (HR)

Heart Rate is available in all cardiac packages. The Heart Rate is not calculated using the ECG trace.

Saving the heart rate to the patient report overwrites any heart rate entered on the patient information form.

- 1 On a frozen Doppler spectral trace, press the CALCS key.
- 2 From the calculations menu, select **HR**.

A vertical caliper appears.
- 3 Using the touchpad, position the first vertical caliper at the peak of the heartbeat.
- 4 Press the SELECT key.

A second vertical caliper appears. The active caliper is highlighted green.
- 5 Using the touchpad, position the second vertical caliper at the peak of the next heartbeat.
- 6 Save the calculation. (See [“To save a calculation”](#) on page 62.)

To calculate Cardiac Output (CO) or Cardiac Index (CI)

The CO and CI calculations require Stroke Volume and Heart Rate calculations. CI also requires Body Surface Area (BSA). After the measurements are saved, the result appears in the patient report.

- 1 (CI Only) Fill in the **Height** and **Weight** fields on the patient information form. The BSA is calculated automatically. (See [“To edit a patient information form”](#) on page 45.)
- 2 Calculate SV. See [“To calculate Stroke Volume \(SV\) or Stroke Index \(SI\)”](#) on page 78.
- 3 Calculate HR. See [“To calculate Heart Rate \(HR\)”](#) on page 78.

To perform a Tissue Doppler Imaging (TDI) calculation

- 1 Ensure that TDI is on. (See [“PW Doppler options”](#) on page 40.)
- 2 On a frozen Doppler spectral trace, press the CALCS key.
- 3 From the calculations menu, select **TDI**, and then do the following for each measurement you want to take:
 - a From the calculations menu, select the measurement name.
 - b Position the calipers. (See [“Working with calipers”](#) on page 55.)
 - c Save the calculation. (See [“To save a calculation”](#) on page 62.)

Gynecology (Gyn) calculations

Gynecology (Gyn) calculations include Uterus, Ovary, Follicle, and Volume. For instructions to calculate volume, see [“Volume calculations”](#) on page 65.

WARNING: To avoid incorrect calculations, verify that the patient information, date, and time settings are accurate.

To avoid misdiagnosis or harming the patient outcome, start a new patient information form before starting a new patient exam and performing calculations. Starting a new patient information form clears the previous patient’s data. The previous patient’s data will be combined with the current patient if the form is not first cleared. See [“To create a new patient information form”](#) on page 45.

Transducers and Exam Types for Gynecology (Gyn) Calculations

Transducer	Exam Type
C60x	Gyn
ICTx	Gyn

To measure uterus or ovary

- 1 On a frozen 2D image, press the CALCS key.
- 2 From the calculations menu, select **Gyn**.
- 3 Do the following for each measurement you want to take:
 - a Select the measurement name from the calculations menu.
 - b Position the calipers. (See [“Working with calipers”](#) on page 55.)

- c Save the calculation. (See [“To save a calculation”](#) on page 62.)

To measure follicles

You can save up to six follicular measurements, one distance measurement for each of up to six follicles.

- 1 On a frozen 2D image, press the CALCS key.
- 2 From the calculations menu, select **Follicle**.
- 3 Do the following for each follicle you want to measure:
 - a From the calculations menu, select the measurement name under **Right Fol** or **Left Fol**.
 - b Position the calipers. (See [“Working with calipers”](#) on page 55.)
 - c Save the calculation. (See [“To save a calculation”](#) on page 62.)

IMT calculations

WARNING:	<p>To ensure high quality images, all patient images must be obtained by qualified and trained individuals.</p> <p>To avoid patient injury, IMT results should not be used as a sole diagnostic tool. All IMT results should be interpreted in conjunction with other clinical information or risk factors.</p> <p>To avoid measurement errors, all measurements must be of the common carotid artery (CCA). This tool is not intended for measuring the bulb or the internal carotid artery (ICA).</p> <p>To avoid incorrect calculations, verify that the patient information, date, and time settings are accurate.</p> <p>To avoid misdiagnosis or harming the patient outcome, start a new patient information form before starting a new patient exam and performing calculations. Starting a new patient information form clears the previous patient's data. The previous patient's data will be combined with the current patient if the form is not first cleared. See “To create a new patient information form” on page 45.</p>
-----------------	---

Transducers and Exam Type for IMT Calculations

Transducer	Exam Type
L38x	IMT
HFL38x	IMT

The following table shows available measurements for IMT calculations. The IMT measurement names are specified on the IMT setup page. See [“IMT Calculations setup”](#) on page 25.

IMT Calculations (2D)

Menu Heading	Available Measurements
Right-IMT	Ant N (Anterior Near Wall)
Left-IMT	Ant F (Anterior Far Wall)
	Lat N (Lateral Near Wall)
	Lat F (Lateral Far Wall)
	Post N (Posterior Near Wall)
	Post F (Posterior Far Wall)
	IMT 1
	IMT 2
	IMT 3
	IMT 4
	IMT 5
	IMT 6
	IMT 7
	IMT 8
Plaque	Plaq 1
	Plaq 2





To calculate IMT automatically

- 1 On a frozen 2D image, press the CALCS key.
- 2 From the calculations menu, select the measurement.
- 3 Using the touchpad or arrow keys, position the IMT tool over the area of interest until the measurement results appear.
- 4 Adjust the tool, and edit as needed. See [“IMT tool options”](#) on page 82.
- 5 Save the calculation. (See [“To save a calculation”](#) on page 62.)

IMT tool options

When using the IMT tool, you can select the following options on-screen.

IMT Tool Options

Option	Icon	Description
Hide		Use to check results. Hides the measurement results and trace line. Select Show to redisplay them.
Move		Repositions the tool horizontally by several pixels. The upper key moves the tool right, and the lower key moves the tool left.
Width		Adjusts the tool width by 1 mm. The upper key increases the width, and the lower key decreases the width.
Edit		Displays Smooth , Adven , and Lumen .
Smooth		Adjusts the IMT line smoothing. Select Edit to display this option.
Adven		Adjusts the adventitia-media line. The upper key moves the line upward. The lower key moves the line downward. Select Edit to display this option.
Lumen		Adjusts the lumen-intima line. The upper key moves the line upward. The lower key moves the line downward. Each of the two IMT lines can be adjusted independently. Select Edit to display this option.

To trace IMT manually

In manually tracing IMT, the user defines the location.

- 1 On a frozen 2D image, press the CALCS key
- 2 From the calculations menu, select a measurement name.
- 3 Select **Edit** on-screen, and then select **Manual**, and then select **Sketch**.
A single caliper appears, and *Trace* appears next to the measurement.
- 4 Do the following for the desired adventitia-media boundary and then for the lumen-intima boundary:
 - a Position the caliper at the beginning of the boundary, and press the SELECT key.
 - b Using the touchpad, mark points by moving the caliper to the next desired point and pressing the SELECT key.

To make a correction, select **Undo** on-screen or press the BACKSPACE key to delete the last segment.

- c Press the SET key to complete the trace line.
- 5 Save the calculation. (See [“To save a calculation”](#) on page 62.)

To sketch IMT

The IMT sketch measurement involves two user-defined sketch lines that you can adjust manually.

- 1 On a frozen 2D image, press the CALCS key
- 2 From the calculations menu, select a measurement name.
- 3 Select **Edit** on-screen, and then select **Manual**.

A single caliper appears on-screen, and *Sketch* appears next to the measurement.
- 4 Do the following for the desired adventitia-media boundary and then for the lumen-intima boundary:
 - a Position the caliper at the beginning of the boundary and press the SELECT key.
 - b Using the touchpad, mark points by moving the caliper to the next desired point and pressing the SELECT key.

To make a correction, select **Undo** on-screen or press the BACKSPACE key to delete the last segment.
 - c Press the SET key to complete the trace line.
 - d If necessary, adjust or edit the measurement. See [“IMT tool options”](#) on page 82.
 - e Save the calculation. (See [“To save a calculation”](#) on page 62.)

OB calculations

EFW is calculated only after appropriate measurements are completed. If any one of these parameters results in an EDD greater than what the OB tables provide, the EFW is not displayed.

WARNING: Make sure that you have selected the OB exam type and the OB calculations author for the OB table you intend to use. See [“System-Defined OB Calculations and Table Authors”](#) on page 86.

To avoid incorrect obstetrics calculations, verify with a local clock and calendar that the system’s date and time settings are correct before each use of the system. The system does not automatically adjust for daylight savings time changes.

To avoid misdiagnosis or harming the patient outcome, start a new patient information form before starting a new patient exam and performing calculations. Starting a new patient information form clears the previous patient's data. The previous patient's data will be combined with the current patient if the form is not first cleared. See ["To create a new patient information form"](#) on page 45.

Prior to use, verify that OB custom table data entries are correct. The system does not confirm the accuracy of the custom table data entered by the user.

Transducers and Exam Types for OB Calculations

Transducer	Exam Type
C60x	OB
ICTx	OB
P21x	OB

OB Calculation Terms in Patient Report and Patient Information Form

Acronym	Term Definition
AUA	Average Ultrasound Age Calculated by averaging the individual ultrasound ages for the fetal biometry measurements performed during the exam. The measurements used to determine the AUA are based on the selected OB calculation authors.
EDD by AUA	Estimated Date of Delivery by Average Ultrasound Age The estimated date of delivery calculated from the measurements performed during the exam.
EDD by LMP	Estimated Date of Delivery by Last Menstrual Period The due date calculated from the user-entered LMP.
EFW	Estimated Fetal Weight Calculated from the measurements performed during the exam. The measurements used to determine EFW are defined by the currently selected EFW calculation author.
Estab. DD	Established Due Date A user-entered due date based on previous exam data or other available information. The LMP is derived from the Established Due Date and is listed in the patient report as LMPd.

OB Calculation Terms in Patient Report and Patient Information Form (Continued)

Acronym	Term Definition
GA by LMP	Gestational Age by Last Menstrual Period The fetal age calculated using the date of the Last Menstrual Period (LMP).
GA by LMPd	Gestational Age by derived Last Menstrual Period The fetal age calculated using the Last Menstrual Period (LMPd) derived from the Estab. DD.
LMP	Last Menstrual Period The first day of the last menstrual period. Used to calculate gestational age and EDD.
LMPd	derived Last Menstrual Period Calculated from the user-entered Estab. DD.
UA	Ultrasound Age Calculated on the mean measurements taken for a particular fetal biometry.

If you change the calculation author during the exam, the common measurements are retained.

The following table shows the system-defined measurements available for OB calculations by author. For definition of the acronyms, see “[Glossary](#)” on page 179. To select authors, see “[OB Calculations setup](#)” on page 26.

See also “[OB Custom Measurements setup](#)” on page 27 and “[OB Custom Tables setup](#)” on page 28.

System-Defined OB Calculations and Table Authors

Calculation Result	Gestational OB Measurements	Table Authors
Gestational Age ^a	GS	Hansmann, Nyberg, Tokyo U.
	CRL	Hadlock, Hansmann, Osaka, Tokyo U.
	BPD	Chitty, Hadlock, Hansmann, Osaka, Tokyo U.
	OFD	Hansmann
	HC	Chitty, Hadlock, Hansmann
	TTD	Hansmann, Tokyo U. ^b
	APTD	Tokyo U. ^b
	AC	Hadlock, Hansmann, Tokyo U.
	FTA	Osaka
	FL	Chitty, Hadlock, Hansmann, Osaka, Tokyo U.
Estimated Fetal Weight (EFW) ^c	HC, AC, FL	Hadlock 1
	BPD, AC, FL	Hadlock 2
	AC, FL	Hadlock 3
	BPD, TTD	Hansmann
	BPD, FTA, FL	Osaka U.
	BPD, AC	Shepard
	BPD, TTD, APTD, FL	Tokyo U.

System-Defined OB Calculations and Table Authors (Continued)

Calculation Result	Gestational OB Measurements	Table Authors
Ratios	HC/AC	Campbell
	FL/AC	Hadlock
	FL/BPD	Hohler
	FL/HC	Hadlock
Amniotic Fluid Index	Q ¹ , Q ² , Q ³ , Q ⁴	Jeng
Growth Analysis Tables ^d	BPD	Chitty, Hadlock, Jeanty
	HC	Chitty, Hadlock, Jeanty
	AC	Chitty, Hadlock, Jeanty
	FL	Chitty, Hadlock, Jeanty
	EFW	Hadlock, Jeanty
	HC/AC	Campbell

a. The Gestational Age is automatically calculated and displayed next to the OB measurement you selected. The average of the results is the AUA.

b. For Toyko U., APTD and TTD are used only to calculate EFW. No age or growth tables are associated with these measurements.

c. The Estimated Fetal Weight calculation uses an equation that consists of one or more fetal biometry measurements. The author for the OB tables, which you choose on a system setup page, determines the measurements you must perform to obtain an EFW calculation. (See “OB Calculations setup” on page 26.) Individual selections for Hadlock’s EFW equations 1, 2, and 3 are not determined by the user. The selected equation is determined by the measurements that have been saved to the report with priority given to the order listed above.

d. The Growth Analysis tables are used by the Report Graphs feature. Three growth curves are drawn using the table data for the selected growth parameter and published author. Growth tables are only available with a user-entered LMP or Estab. DD.

To measure gestational growth (2D)

For each 2D OB measurement (except AFI), the system saves up to three individual measurements and their average. If you take more than three measurements, the earliest measurement is deleted.

- 1 In the patient information form, select **OB** exam type, and select **LMP** or **Estab.DD**. Select **Twins** if appropriate.
- 2 On a frozen 2D image, press the CALCS key.

3 Do the following for each measurement you want to take:

- a** From the calculations menu, select the measurement name. For twins, select **Twin A** or **Twin B**, and then select the measurement name.

The caliper tool may change depending on the measurement selected, but the position remains constant.

- b** Position the calipers. (See [“Working with calipers”](#) on page 55.)
- c** Save the calculation. (See [“To save a calculation”](#) on page 62.)

To measure fetal heart rate (M Mode)

1 On a frozen M Mode trace, press the CALCS key.

2 Select **FHR** from the calculations menu.

A vertical caliper appears.

3 Using the touchpad, position the vertical caliper at the peak of the heartbeat.

4 Press the SELECT key.

A second vertical caliper appears.

5 Using the touchpad, position the second vertical caliper at the peak of the next heartbeat.

6 Save the calculation. (See [“To save a calculation”](#) on page 62.)

Saving the heart rate measurement to the patient report overwrites any heart rate entered on the patient information form.

OB Doppler Calculations

Menu Heading	OB Calculation	Results
MCA (Middle Cerebral Artery)	S/D, RI	SD RI
	S/D, RI, PI*	SD RI PI
Umb A (Umbilical Artery)	S/D, RI	SD RI
	S/D, RI, PI*	SD RI PI

*Calculation requires a trace measurement.

To calculate MCA or Umba (Doppler)

Note: The system does not provide an MCA/UmbA ratio from the PI (Pulsatility Index).

- 1 Select **OB** exam type, and select **LMP** or **Estab.DD** in the patient information form.
- 2 On a frozen Doppler spectral trace, press the CALCS key.
- 3 Do the following for each measurement you need to take:
 - a From the calculations menu, select the measurement name under **MCA** (Middle Cerebral Artery) or **UmbA** (Umbilical Artery).
 - b Position the calipers:
 - For **S/D, RI**, position the first caliper at the peak systolic waveform. Press the SELECT key, and position the second caliper at the end diastole on the waveform.
 - For **S/D, RI, PI**, position the caliper at the beginning of the desired waveform, and press the SELECT key. Use the touchpad to manually trace the desired area. Press the SET key.
If calipers are not positioned correctly, the calculation result is inaccurate.
 - c Save the calculation. (See “To save a calculation” on page 62.)
Only one calculation (**S/D, RI** or **S/D, RI, PI**) can be saved.

Small Parts calculations

Small Parts calculations include volume, hip angle, and d:D ratio. For instructions to calculate volume, see “Volume calculations” on page 65.

Transducers and Exam Types for Hip Angle and d:D Ratio Calculations

Transducer	Exam Type
HFL38x	Small Parts
L38x	Small Parts

To calculate hip angle

- 1 On a frozen 2D image, press the CALCS key.
- 2 From the calculations menu, select **Right** or **Left**.
- 3 Select **Baseline** under **Hip Angle**.
A baseline appears on-screen.
- 4 Position the baseline, and press the SET key. (See “Working with calipers” on page 55.)
Line A (alpha line) appears on-screen, and **Line A** is selected in the calculations menu.
- 5 Position Line A, and save the measurement. (See “To save a calculation” on page 62.)
Line B (beta line) appears on-screen, and **Line B** is selected in the calculations menu.

6 Position Line B, and save the measurement.

To calculate d:D ratio

1 On a frozen 2D image, press the CALCS key.

2 From the calculations menu, select **Right** or **Left**.

3 Under **d:D Ratio**, select **Fem Hd** (femoral head).

4 Using the touchpad, position and resize the circle. The SELECT key toggles between position and size.

5 Press the SET key.

The baseline automatically appears with the left caliper active.

6 Position the caliper. (See [“Working with calipers”](#) on page 55.)

7 Save the measurement. (See [“To save a calculation”](#) on page 62.)

Vascular calculations

WARNING: To avoid misdiagnosis or harming the patient outcome, start a new patient information form before starting a new patient exam and performing calculations. Starting a new patient information form clears the previous patient's data. The previous patient's data will be combined with the current patient if the form is not first cleared. See [“To create a new patient information form”](#) on page 45.

To avoid incorrect calculations, verify that the patient information, date, and time settings are accurate.

Transducers and Exam Types for Vascular Calculations

Transducer	Exam Type
HFL38x	Vascular
L25x	Vascular
L38x	Vascular
P10x	Vascular

The vascular measurements that you can save to the patient report are listed in the following table. For definitions of acronyms, see “Glossary” on page 179.

Vascular Calculations

Menu Heading	Vascular Measurement	Calculation Results
CCA	Prox	s (systolic), d (diastolic)
	Mid	s (systolic), d (diastolic)
	Dist	s (systolic), d (diastolic)
	Bulb	s (systolic), d (diastolic)
ICA	Prox	s (systolic), d (diastolic)
	Mid	s (systolic), d (diastolic)
	Dist	s (systolic), d (diastolic)
ECA	Prox	s (systolic), d (diastolic)
	Mid	s (systolic), d (diastolic)
	Dist	s (systolic), d (diastolic)
	VArty	s (systolic), d (diastolic)

To perform a Vascular calculation

After you perform vascular measurements, values in the ICA/CCA ratios are selectable on the vascular page of the patient report.

- 1 On a frozen Doppler spectral trace, press the CALCS key.
- 2 From the calculations menu, select **Left** or **Right**.
- 3 Do the following for each measurement you want to take:
 - a From the calculations menu, select the measurement name.
 - b Using the touchpad, position the caliper at the peak systolic waveform.
 - c Press the SELECT key.
A second caliper appears.
 - d Using the touchpad, position the second caliper at the end diastole on the waveform.
 - e Save the calculation. (See “To save a calculation” on page 62.)

Patient report

The patient report contains calculation results. The last page contains patient information. The patient report for Cardiac, OB, and Vascular exams have additional details and features.

You can view the patient report at any time during the exam.

The value for a calculation appears only if the calculation has been performed. The pound symbol (###) indicates a value that is out of range (for example, too large or small). Calculation values that are out of range are not included in derived calculations (for example, mean).

To view a patient report

- 1 Press the REPORT key.
 - 2 To view additional pages, select  **1/x** on-screen.
 - 3 (Optional) Press the SAVE key to save the current page of the patient report.
- To exit the patient report and return to imaging, select **Done**.

Vascular and cardiac reports

To view a vascular or cardiac report

- 1 After or during the vascular or cardiac exam, press the REPORT key.
- 2 Do any of the following:
 - To view additional pages, select  **1/x** on-screen.
 - To view details or the summary, select **Details** or **Summary** on-screen. The mean of the detail entries is used in the summary.
 - To delete a measurement, use the touchpad on the **Details** page to select the measurement. (The selected measurement is green.) Select **Delete** on-screen.

Deleting some measurements also deletes related measurements. Deleted measurements are not included in the summary information.
- 3 (Vascular Only) In the **Ratio** list, select measurements for the ICA/CCA ratio for both the right and left sides.
- 4 (Cardiac Only) To adjust the RA pressure, select from the **RA** list.

Changing the RA pressure from the default number 5 affects the RVSP calculation result.

OB reports

The OB report pages have a signature space for signing printed reports.

To view the OB Twins report (individual)

- 1 After or during the OB exam, press the REPORT key.
- 2 Select **Twin A/B** on-screen to view individual twin reports.

To view the OB Twins report (combined)

- 1 After or during the OB exam, press the REPORT key.
- 2 Select **Compare** on-screen to view both twins in a single report.

To delete an OB measurement

- 1 After or during the OB exam, press the REPORT key.
- 2 Using the touchpad, select the desired OB measurement.

The selected measurement is highlighted green.

- 3 Select **Delete** on-screen.

To delete all measurements, select the measurement label and press the SELECT key and then select **Delete** on-screen.



Figure 3 OB Anatomy Checklist Page

To view the OB Anatomy Checklist page

- 1 After or during the OB exam, press the REPORT key.
- 2 On the page for Anatomy Demonstrated, select the check boxes to document reviewed anatomy.

Press the TAB key to move between fields and the SPACEBAR to select and deselect items in the checklist.

To view the OB Biophysical Profile page

- 1 After or during the OB exam, press the REPORT key.
- 2 On page 2 of the report, select values for the biophysical profile (BPP) (**0, 1, 2**).
The total score is calculated when values are entered. NST (non-stress test) is optional.

To view OB graphs

OB Graphs may be viewed if **LMP** or **Estab. DD** is entered in the patient information form.

- 1 After or during the OB exam, press the REPORT key.
- 2 Select **Graphs** on-screen.
- 3 In the **Graphs** list, select the desired measurement/author.
The graph for the selected measurement appears. You can select another measurement/author or select  **1/x** on-screen.
For twins, both measurement sets are plotted on the same graph.
- 4 (Optional) Press the SAVE key to save the current graph page.
- 5 Select one of the following on-screen:
 - **Report** to return to the previous report page
 - **Done** to return to live imaging.

Sending reports and viewing EMED worksheets

To send a report to a PC

You can send a report to a PC as a text file.

- 1 Ensure correct configuration. See [“To configure the system for a DVD recorder, PC, or bar code scanner”](#) on page 24.
- 2 Select **Send Rep.** on-screen.

To view EMED Worksheets

This feature is optional.

- 1 At the end of an exam, press the REPORT key.
- 2 Select **EMED** on-screen.
- 3 Select the desired worksheet: **AAA, FAST, Gallbladder (GB), Kidney.**

Chapter 5: Troubleshooting and Maintenance

This chapter contains information to help correct problems with system operation, to enter a software license, and to take proper care of the system, transducer, and accessories.

Troubleshooting

If you encounter difficulty with the system, use the following table to help troubleshoot the problem. If the problem persists, contact SonoSite Technical Support. (See [“SonoSite Technical Support”](#) on page viii.)

Troubleshooting

Symptom	Solution
System does not turn on.	Check all power connections. Remove the DC input connector and battery, wait 10 seconds, and then reinstall them. Ensure that the battery is charged.
System image quality is poor.	Adjust the LCD screen to improve viewing angle. Adjust the brightness. Adjust the gain.
No CPD image.	Adjust the gain.
No Color image.	Adjust the gain or the scale.
No OB measurement selections.	Select the OB exam type.
Print does not work.	Select the printer on the Connectivity setup page. See “To configure the system for a printer” on page 24. Check the printer connections. Ensure that the printer is turned on and set up properly. See the printer manufacturer’s instructions, if necessary.
DVD recorder does not record.	Check the DVD recorder connections. Ensure that the DVD recorder is turned on and set up properly. See the applicable SonoSite accessory user guide and the manufacturers’ instructions.

Troubleshooting (Continued)

Symptom	Solution
External monitor does not work.	Check the monitor connections. Check the monitor to ensure that it is turned on and set up properly. See the monitor manufacturers' instructions, if necessary.
System does not recognize the transducer.	Disconnect and reconnect the transducer.
A maintenance icon  appears on the system screen.	System maintenance may be required. Record the number in parentheses on the C: line and contact SonoSite or your SonoSite representative.

Software licensing

SonoSite software is controlled by a license key. After you install new software, the system prompts you for a license key. You must obtain one key for each system or transducer that uses the software.

The software will operate for a short time (the “grace period”) without a license key. During the grace period, all system functions are available. After the grace period, the system is not usable until you enter a valid license key. Grace period time is not used while the system is off or asleep. Grace period time remaining appears on the license update screen.

Caution: After the grace period expires, all system functions except licensing are unavailable until a valid license key is entered.

To obtain a license key for your software, contact SonoSite Technical Support. (See “[SonoSite Technical Support](#)” on page viii.) You need to provide the following information. (See “[System Information setup](#)” on page 30.)

Software License Key Information

System Software	Transducer Software
Name of person installing the upgrade	Name of person installing the upgrade
Serial number (on bottom of system)	Transducer serial number
ARM version	Transducer part number (REF) or model number (for example, C60x)
PCBA serial number	Transducer bundle version

After you obtain a license key, you must enter it into the system.

To enter a license key

- 1 Turn on the system.

The license update screen appears.

- 2 Enter the license key in the **Enter license number** field.

- 3 Select **Done** on-screen.

If you entered a valid license key but the license update screen appears, verify that you entered the license key correctly. If the license update screen still appears, contact SonoSite Technical Support. (See [“SonoSite Technical Support”](#) on page viii.)

Maintenance

Use the recommendations in this section when cleaning or disinfecting your ultrasound system, transducer, and accessories. Use the cleaning recommendations in the peripheral manufacturer’s instructions when cleaning or disinfecting your peripherals.

No periodic or preventive maintenance is required for the system, transducer, or accessories other than cleaning and disinfecting the transducer after every use. (See [“Cleaning and disinfecting transducers”](#) on page 99.) There are no internal components that require periodic testing or calibration. All maintenance requirements are described in this chapter and in the ultrasound system service manual. Performing maintenance procedures not described in the user guide or service manual may void the product warranty.

Contact SonoSite Technical Support for any maintenance questions. (See [“SonoSite Technical Support”](#) on page viii.)

WARNING:

Disinfectants and cleaning methods listed are recommended by SonoSite for compatibility with product materials, not for biological effectiveness. Refer to the disinfectant label instructions for guidance on disinfection efficacy and appropriate clinical uses.

The level of disinfection required for a device is dictated by the type of tissue it will contact during use. To avoid infection, ensure that the disinfectant type is appropriate for the equipment. For information, see the disinfectant label instructions and the recommendations of the Association for Professionals in Infection Control and Epidemiology (APIC) and the U.S. Food and Drug Administration (FDA).

To prevent contamination, the use of sterile transducer sheaths and sterile coupling gel is recommended for clinical applications of an invasive or surgical nature. Do not apply the transducer sheath and gel until you are ready to perform the procedure.

Caution:

Some transducer sheaths contain natural rubber latex and talc, which can cause allergic reactions in some individuals. Refer to 21 CFR 801.437, User labeling for devices that contain natural rubber.

Cleaning and disinfecting the ultrasound system

The exterior surface of the ultrasound system and the accessories can be cleaned and disinfected using a recommended cleaner or disinfectant. See [Table 1, “Disinfectants Compatible with System and Transducers”](#) on page 104.

WARNING:	<p>To avoid electrical shock, before cleaning, disconnect the system from the power supply or remove from the mini-dock or docking system.</p> <p>To avoid infection always use protective eyewear and gloves when performing cleaning and disinfecting procedures.</p> <p>To avoid infection, ensure that the solution expiration date has not passed.</p> <p>To avoid infection, the level of disinfection required for a product is dictated by the type of tissue it contacts during use. Ensure that the solution strength and duration of contact are appropriate for the equipment. For information, see the disinfectant label instructions and the recommendations of the Association for Professionals in Infection Control and Epidemiology (APIC) and FDA.</p>
Caution:	<p>Do not spray cleaners or disinfectant directly on the system surfaces. Doing so may cause solution to leak into the system, damaging the system and voiding the warranty.</p> <p>Do not use strong solvents such as thinner or benzene, or abrasive cleansers, since these will damage the exterior surfaces.</p> <p>Use only recommended cleaners or disinfectants on system surfaces. Immersion-type disinfectants are not approved for use on system surfaces.</p> <p>When you clean the system, ensure that the solution does not get inside the system controls or the battery compartment.</p> <p>Do not scratch the LCD screen.</p>

To clean the LCD screen

- ❖ Dampen a clean, non-abrasive, cotton cloth with an ammonia-based window cleaner, and wipe the screen clean.
Apply the cleaner to the cloth rather than the surface of the screen.

To clean and disinfect system surfaces

- 1 Turn off the system.
- 2 Disconnect the system from the power supply, or remove it from the mini-dock or docking system.
- 3 Clean the exterior surfaces using a soft cloth lightly dampened in a mild soap or detergent cleaning solution to remove any particulate matter or body fluids.
Apply the solution to the cloth rather than the surface.

- 4 Mix the disinfectant solution compatible with the system, following disinfectant label instructions for solution strengths and disinfectant contact duration.
- 5 Wipe surfaces with the disinfectant solution.
- 6 Air dry or towel dry with a clean cloth.

Cleaning and disinfecting transducers

To disinfect the transducer and its cable, use the immersion method or the wipe method. Immersible transducers can be disinfected only if the product labeling indicates they can be used with an immersion method.

See [Table 1, “Disinfectants Compatible with System and Transducers”](#) on page 104.

WARNING: To avoid electrical shock, before cleaning, disconnect the transducer from the system.

To avoid injury, always use protective eyewear and gloves when performing cleaning and disinfecting procedures.

To avoid infection, ensure that the solution expiration date has not passed.

To avoid infection, the level of disinfection required for a transducer is dictated by the type of tissue it contacts during use. Ensure that the solution strength and duration of contact are appropriate for the equipment. SonoSite tests products for compatibility of materials only. SonoSite does not test for biological effectiveness. For information, see the disinfectant label instructions and the recommendations of the Association for Professionals in Infection Control and Epidemiology (APIC) and FDA.

Caution: Transducers must be cleaned after every use. Cleaning transducers is necessary prior to effective disinfection. Ensure that you follow the manufacturer's instructions when using disinfectants.

Do not use a surgeon's brush when cleaning transducers. Even the use of soft brushes can damage a transducer. Use a soft cloth.

Using a non-recommended cleaning or disinfection solution, incorrect solution strength, or immersing a transducer deeper or for a longer period of time than recommended can damage or discolor the transducer and void the transducer warranty.

Do not allow cleaning solution or disinfectant into the transducer connector.

Do not allow disinfectant to contact metal surfaces. Use a soft cloth lightly dampened in a mild soap or compatible cleaning solution to remove any disinfectant that remains on metal surfaces.

Attempting to disinfect a transducer or transducer cable using a method other than the one included here can damage the transducer and void the warranty.

To clean and disinfect a transducer (wipe method)

- 1** Disconnect the transducer from the system.
- 2** Remove any transducer sheath.
- 3** Clean the surface using a soft cloth lightly dampened in a mild soap or detergent cleaning solution to remove any particulate matter or body fluids.
Apply the solution to the cloth rather than the surface.
- 4** Rinse with water or wipe with water-dampened cloth, then wipe with a dry cloth.
- 5** Mix the disinfectant solution compatible with the transducer, following disinfectant label instructions for solution strengths and disinfectant contact duration.
- 6** Wipe surfaces with the disinfectant solution.
- 7** Air dry or towel dry with a clean cloth.
- 8** Examine the transducer and cable for damage such as cracks, splitting, or fluid leaks.
If damage is evident, discontinue use of the transducer, and contact SonoSite or your local representative.

To clean and disinfect a transducer (immersion method)

- 1** Disconnect the transducer from the system.
- 2** Remove any transducer sheath.
- 3** Clean the surface using a soft cloth lightly dampened in a mild soap or compatible cleaning solution to remove any particulate matter or body fluids.
Apply the solution to the cloth rather than the surface.
- 4** Rinse with water or a wipe with water-dampened cloth, and then wipe with a dry cloth.
- 5** Mix the disinfectant solution compatible with the transducer, following disinfectant label instructions for solution strengths and disinfectant contact duration.
- 6** Immerse the transducer into the disinfection solution not more than 12-18 inches (31-46 cm) from the point where the cable enters the connector.
Follow the instructions on the disinfectant label for the duration of the transducer immersion.
- 7** Using the instructions on the disinfectant label, rinse to the point of the previous immersion, and then air dry or towel dry with a clean cloth.
- 8** Examine the transducer and cable for damage such as cracks, splitting, or fluid leaks.
If damage is evident, discontinue use of the transducer, and contact SonoSite or your local representative.

Cleaning and disinfecting transducer cables

The transducer cable can be disinfected using a recommended wipe or immersion disinfectant. Before disinfecting, orient the cable to ensure that the transducer and system do not get immersed.

WARNING: To avoid infection, ensure that the solution expiration date has not passed.

Caution: Attempting to disinfect a transducer cable using a method other than the one included here can damage the transducer and void the warranty.

To clean and disinfect a transducer cable (wipe method)

- 1 Disconnect the transducer from the system.
- 2 Remove any transducer sheath.
- 3 Clean the transducer cable using a soft cloth lightly dampened in a mild soap or detergent cleaning solution to remove any particulate matter or body fluids.
Apply the solution to the cloth rather than the surface.
- 4 Rinse with water or wipe with water-dampened cloth, then wipe with a dry cloth.
- 5 Mix the disinfectant solution compatible with the transducer cable, following disinfectant label instructions for solution strengths and disinfectant contact duration.
- 6 Wipe surfaces with the disinfectant solution.
- 7 Air dry or towel dry with a clean cloth.
- 8 Examine the transducer and cable for damage such as cracks, splitting, or fluid leaks.
If damage is evident, discontinue use of the transducer, and contact SonoSite or your local representative.

To clean and disinfect a transducer cable (immersion method)

- 1 Disconnect the transducer from the system.
- 2 Remove any transducer sheath.
- 3 Clean the transducer cable using a soft cloth lightly dampened in a mild soap or compatible cleaning solution to remove any particulate matter or body fluids.
Apply the solution to the cloth rather than the surface.
- 4 Rinse with water or a wipe with water-dampened cloth, then wipe with a dry cloth.
- 5 Mix the disinfectant solution compatible with the transducer cable, following disinfectant label instructions for solution strengths and disinfectant contact duration.
- 6 Immerse the transducer cable into the disinfection solution.
Follow the instructions on the disinfectant label for the duration of the transducer cable immersion.

- 7 Using the instructions on the disinfectant label, rinse the transducer cable, and then air dry or towel dry with a clean cloth.
- 8 Examine the transducer and cable for damage such as cracks, splitting, or fluid leaks.
If damage is evident, discontinue use of the transducer, and contact SonoSite or your local representative.

Cleaning and disinfecting the battery

Caution: To avoid damaging the battery, do not allow cleaning solution or disinfectant to come in contact with the battery terminals.

To clean and disinfect a battery (wipe method)

- 1 Remove the battery from the system.
- 2 Clean the surface using a soft cloth lightly dampened in a mild soap or detergent cleaning solution.
Apply the solution to the cloth rather than the surface.
- 3 Wipe the surfaces with the disinfection solution. Theracide disinfectant is recommended.
- 4 Air dry or towel dry with a clean cloth.

Cleaning the footswitch

Caution: To avoid damaging the footswitch, do not sterilize. It is not intended for use in a sterile environment.

To clean the footswitch

- 1 Dampen a non-abrasive cloth with one of the following products:
 - Isopropyl alcohol
 - Soap and water
 - Cidex
 - Sodium Hypochlorite 5.25% (Bleach) diluted 10:1
- 2 Wring out cloth until slightly wet and then gently rub soiled area until clean.

Cleaning and disinfecting ECG cables

Caution: To avoid damaging the ECG cable, do not sterilize.

To clean and disinfect the ECG cable (wipe method)

- 1 Remove the cable from the system.

2 Clean the surface using a soft cloth lightly dampened in a mild soap or detergent cleaning solution.

Apply the solution to the cloth rather than the surface.

3 Wipe the surfaces with any of the following products:

- Bleach (sodium hypochlorite)
- Cidex disinfectants
- Green soap
- Theracide

4 Air dry or towel dry with a clean cloth.

Table 1 does not have the following regulatory information for disinfectants:

- EPA Registration
- FDA 510(k) clearance (liquid sterilant, high level disinfectant)
- CE approval

Prior to use, confirm that the regulatory status of the disinfectant is appropriate for your jurisdiction and use.

See www.sonosite.com for updated cleaning and disinfectant information. Click **Quick Link**, and then click **Documentation**.

Table 1: Disinfectants Compatible with System and Transducers

Disinfection and Cleaning Solutions	Country of Origin	Type	Active Ingredient	C60x/ICTx/ L38x/P21x	HFL38x	C11x/ L25x	System Surfaces
AbcoCide 14	USA	Liquid	Gluteraldehyde	A	A	A	U
Accel Wipes	CAN	Wipe	Hydrogen Peroxide	A	A	A	U
Accel Plus	CAN	Wipe	Hydrogen Peroxide	N	N	N	U
Accel TB	CAN	Wipe	Hydrogen Peroxide	N	N	N	U
Aidal Plus	AUS	Liquid	Gluteraldehyde	A	A	A	U
Alkacide	FRA	Liquid	Gluteraldehyde	A	A	A	U
Alkazyme	FRA	Liquid	Quat. Ammonia	A	A	A	U
Aquatabs (1000)	IRL	Tablet	Sodium Dichloroisocyanurate	A	N	A	U
Aquatabs (2000)	IRL	Tablet	Sodium Dichloroisocyanurate	A	N	A	U
Aquatabs (5000)	IRL	Tablet	Sodium Dichloroisocyanurate	N	N	N	U

Table 1: Disinfectants Compatible with System and Transducers (Continued)

Disinfection and Cleaning Solutions	Country of Origin	Type	Active Ingredient	C60x/ICTx/ L38x/P21x	HFL38x	C11x/ L25x	System Surfaces
Anioxyde 1000	FRA	Liquid	Peracetic Acid	N	N	N	U
Ascend	USA	Liquid	Quat Ammonia	A	A	A	U
Asepti-HB	USA	Liquid	Quat Ammonia	A	A	A	U
Asepti-Steryl	USA	Spray	Ethanol	A	A	A	U
Asepti-Wipes	USA	Wipe	Propanol (Isopropyl Alcohol)	A	A	A	A
Bacillocid rasant	DEU	Liquid	Glut./Quat. Ammonia	A	A	A	U
Banicide	USA	Liquid	Gluteraldehyde	A	U	A	U
Betadine	USA	Liquid	Providone-Iodine	N	N	A	U
Bleach	USA	Liquid	NaCl Hypochlorite	A	A	A	U
Cavicide	USA	Liquid	Isopropyl	A	A	A	U
Caviwipes	USA	Wipes	Isopropanol	A	A	N	A
Chlor-Clean	GBR	Liquid	Sodium Dichloroisocyanurate	A	N	A	U
Cidex	USA	Liquid	Gluteraldehyde	A	A	A	A
Cidex OPA	USA	Liquid	Ortho-phthaldehyde	A	A	A	U
Cidex Plus	USA	Liquid	Gluteraldehyde	A	A	A	A
Cleanisept	DEU	Wipes	Quat. Ammonia	A	A	A	A
Clorox Wipes	USA	Wipes	Isopropanol	A	A	A	U
Control III	USA	Liquid	Quat. Ammonia	A	A	N	U

Table 1: Disinfectants Compatible with System and Transducers (Continued)

Disinfection and Cleaning Solutions	Country of Origin	Type	Active Ingredient	C60x/ICTx/ L38x/P21x	HFL38x	C11x/ L25x	System Surfaces
Coverage Spray	USA	Spray	Quat. Ammonia	A	A	N	N
DentaSept	FRA	Liquid	Quat. Ammonia	N	N	N	U
Denatured Alcohol	USA	Liquid	Ethanol	N	N	N	U
DisCide Wipes	USA	Wipes	Isopropyl Alcohol	A	A	A	N
DisCide Ultra Disinfecting Towellettes	USA	Wipes	Isopropyl Alcohol	U	U	U	N
DisOPA	JPN	Liquid	Ortho-phthaldehyde	A	A	A	A
Dispatch	USA	Spray	NaCl Hypochlorite	A	A	A	U
End-Bac II	USA	Liquid	Quat. Ammonia	A	A	A	A
Endozime AW Plus	FRA	Liquid	Propanol	A	A	A	U
Envirocide	USA	Liquid	Isopropyl	A	U	N	U
Enzol	USA	Cleaner	Ethylene Glycol	A	A	A	U
Expose	USA	Liquid	Isopropyl	A	A	A	U
Gigasept AF	DEU	Liquid	Quat. Ammonia	A	A	A	U
Gigasept FF	DEU	Liquid	Bersteinsäure	N	N	N	U
Gluteraldehyde SDS	USA	Liquid	Gluteraldehyde	A	U	A	U
Hexanios	FRA	Liquid	Polyhexanide/Quat. Ammonia	A	A	A	U
Hi-Tor Plus	USA	Liquid	Chloride	A	A	N	U
Hibiclens	USA	Cleaner	Chlorhexidine	A	A	A	U

Table 1: Disinfectants Compatible with System and Transducers (Continued)

Disinfection and Cleaning Solutions	Country of Origin	Type	Active Ingredient	C60x/ICTx/ L38x/P21x	HFL38x	C11x/ L25x	System Surfaces
Hydrogen Peroxide	USA	Liquid	Hydrogen Peroxide	A	A	A	A
Isopropanol Alcohol	ALL	Liquid	Alcohol	N	N	N	U
Kodan Tücher	DEU	Liquid	Propanol	A	A	A	N
Kohrsolin ff	DEU	Liquid	Gluteraldehyde	A	U	A	U
Korsolex basic	DEU	Liquid	Gluteraldehyde	N	N	N	U
LpHse	USA	Liquid	O-phenylphenol	A	A	A	U
Lysol	USA	Spray	Ethanol	N	N	N	U
Lysol IC	USA	Liquid	O-phenylphenol	A	N	A	U
Madacide 1	USA	Liquid	Isopropanol	A	A	N	N
Matar	USA	Liquid	O-phenylphenol	A	U	A	U
MetriCide 14	USA	Liquid	Gluteraldehyde	A	A	A	U
MetriCide 28	USA	Liquid	Gluteraldehyde	A	A	A	U
MetriZyme	USA	Cleaner	Propylene Glycol	A	A	A	U
Mikrobak forte	DEU	Liquid	Ammonium Chloride	A	A	A	U
Mikrozid Wipes	DEU	Wipe	Ethanol/Propanol	A	A	A	N
Nuclean	FRA	Spray	Alcohol/Biguanide	A	A	A	U
Precise	USA	Spray	O-phenylphenol	N	N	N	U
Ruthless	USA	Spray	Quat. Ammonia	A	A	N	U
Sagrosept Wipe	DEU	Wipe	Propanol	A	A	A	U
Salvanios pH 7	FRA	Liquid	Quat. Ammonia	A	A	A	U

Table 1: Disinfectants Compatible with System and Transducers (Continued)

Disinfection and Cleaning Solutions	Country of Origin	Type	Active Ingredient	C60x/ICTx/ L38x/P21x	HFL38x	C11x/ L25x	System Surfaces
Sani-Cloth HB	USA	Wipe	Quat. Ammonia	A	A	N	A
Sani-Cloth Plus	USA	Wipe	Quat. Ammonia	A	A	A	A
Sklar	USA	Liquid	Isopropanol	A	A	N	U
Sporicidin	USA	Liquid	Phenol	A	A	A	U
Sporicidin Wipes	USA	Wipe	Phenol	A	A	A	N
Staphene	USA	Spray	Ethanol	A	N	A	N
Steranios	FRA	Liquid	Gluteraldehyde	A	A	A	U
Super Sani-Cloth	USA	Wipe	Isopropyl Alcohol	N	N	N	N
T-Spray	USA	Spray	Quat. Ammonia	A	A	N	N
T-Spray II	USA	Spray	Alkyl/Chloride	A	A	A	U
TASK 105	USA	Spray	Quat. Ammonia	A	A	A	U
TBQ	USA	Liquid	Alkyl	A	A	A	U
Theracide Plus	USA	Liquid	Quat. Ammonia	A	A	A	A
Theracide Plus Wipes	USA	Wipe	Quat. Ammonia	A	A	A	A
Tor	USA	Liquid	Quat. Ammonia	A	A	N	U
Transeptic	USA	Cleaner	Alcohol	N	N	N	U
Tristel	GBR	Liquid	Chlorine Dioxide	A	A	A	U
Tristel Wipes	GBR	Wipe	Chlorine Dioxide	N	N	N	A

Table 1: Disinfectants Compatible with System and Transducers (Continued)

Disinfection and Cleaning Solutions	Country of Origin	Type	Active Ingredient	C60x/ICTx/ L38x/P21x	HFL38x	C11x/ L25x	System Surfaces
Vesphene II	USA	Liquid	Sodium/ o-Phenylphenate	A	A	A	U
Virex II 256	USA	Liquid	Ammonium Chloride	A	A	A	U
Virex TB	USA	Liquid	Quat. Ammonia	A	A	N	N
Virox 5	CAN	Wipe	Hydrogen Peroxide	A	A	A	A
Wavicide -01	USA	Liquid	Gluteraldehyde	N	N	N	U
Wavicide -06	USA	Liquid	Gluteraldehyde	A	A	A	U
Wex-Cide	USA	Liquid	O-phenylphenol	A	A	A	U

A = Acceptable

N = No (Do not use)

U = Untested (Do not use)

Chapter 6: Safety

This chapter contains information required by regulatory agencies, including information about the ALARA (as low as reasonably achievable) principle, the output display standard, acoustic power and intensity tables, and other safety information. The information applies to the ultrasound system, transducer, accessories, and peripherals.

Ergonomic safety

These healthy scanning guidelines are intended to assist you in the comfort and effective use of your ultrasound system.

WARNING:	<p>To prevent musculoskeletal disorders, follow the guidelines in this section.</p> <p>Use of an ultrasound system may be linked to musculoskeletal disorders^{a,b,c}.</p> <p>Use of an ultrasound system is defined as the physical interaction between the operator, the ultrasound system, and the transducer.</p> <p>When using an ultrasound system, as with many similar physical activities, you may experience occasional discomfort in your hands, fingers, arms, shoulders, eyes, back, or other parts of your body. However, if you experience symptoms such as constant or recurring discomfort, pain, throbbing, aching, tingling, numbness, burning sensation, or stiffness, do not ignore these warning signs. Promptly see a qualified health professional. Symptoms such as these can be linked with musculoskeletal disorders (MSDs). MSDs can be painful and may result in potentially disabling injuries to the nerves, muscles, tendons, or other parts of the body. Examples of MSDs include carpal tunnel syndrome and tendonitis.</p> <p>While researchers are not able to definitively answer many questions about MSDs, there is a general agreement that certain factors are associated with their occurrence including: preexisting medical and physical conditions, overall health, equipment and body position while doing work, frequency of work, duration of work, and other physical activities that may facilitate the onset of MSDs^d. This chapter provides guidelines that may help you work more comfortably and may reduce your risk of MSDs^{e,f}.</p>
-----------------	---

a.Magnavita, N., L. Bevilacqua, P. Mirk, A. Fileni, and N. Castellino. "Work-related Musculoskeletal Complaints in Sonologists." *Occupational Environmental Medicine*. 41:11 (1999), 981-988.

b.Craig, M. "Sonography: An Occupational Hazard?" *Journal of Diagnostic Medical Sonography*. 3 (1985), 121-125.

c.Smith, C.S., G.W. Wolf, G. Y. Xie, and M. D. Smith. "Musculoskeletal Pain in Cardiac Ultrasonographers: Results of a Random Survey." *Journal of American Society of Echocardiography*. (May1997), 357-362.

d.Wihlidal, L.M. and S. Kumar. "An Injury Profile of Practicing Diagnostic Medical Sonographers in Alberta." *International Journal of Industrial Ergonomics*. 19 (1997), 205-216.

e.Habes, D.J. and S. Baron. "Health Hazard Report 99-0093-2749." *University of Medicine and Dentistry of New Jersey*. (1999).

f.Vanderpool, H.E., E.A. Friis, B.S. Smith, and K.L. Harms. "Prevalence of Carpal Tunnel Syndrome and Other Work-related Musculoskeletal Problems in Cardiac Sonographers." *Journal of Medicine*. 35:6 (1993), 605-610.

Position the system

Promote comfortable shoulder, arm, and hand postures

- Use a stand to support the weight of the ultrasound system.

Minimize eye and neck strain

- When the exam or procedure allows, position the system within reach.
- Adjust the angle of the system and display to minimize glare from overhead or outside lighting.
- If using a stand, adjust its height so that the display is at or slightly below eye level.

Position yourself

Support your back during an exam

- Use a chair that has support for your lower back, that adjusts to your work surface height, that promotes a natural body posture, and that allows for quick height adjustments.
- Always sit or stand in an upright manner. Avoid bending or stooping.

Minimize reaching and twisting

- Use a bed that is height adjustable.
- Position the patient as close to you as possible.
- Face forward. Avoid twisting your head or body.
- Move your entire body front to back, and position your scanning arm next to or slightly in front of you.
- Stand for difficult exams to minimize reaching.

Promote comfortable shoulder and arm postures

- Keep your elbow close to your side.
- Relax your shoulders in a level position.
- Support your arm using a support cushion or pillow, or rest it on the bed.

Minimize neck bending and twisting

- Position the ultrasound system/display directly in front of you.
- Provide an auxiliary monitor for patient viewing.

Promote comfortable hand, wrist, and finger postures

- Hold the transducer lightly in your fingers.
- Minimize the pressure applied on the patient.
- Keep your wrist in a straight position.

Take breaks, exercise, and vary activities

- Minimizing scanning time and taking breaks can effectively allow your body to recover from physical activity and help you avoid MSDs. Some ultrasound tasks may require longer or more frequent breaks. One way of taking a break is to stop and relax. However, simply changing tasks can help some muscle groups relax while others remain or become active.
- Work efficiently by using the software and hardware features correctly.
- Keep moving. Avoid sustaining the same posture by varying your head, neck, body, arm, and leg positions.
- Targeted exercises can strengthen muscle groups, which may help you avoid MSDs. Contact a qualified health professional to determine stretches and exercises that are right for you.

Electrical safety classification

Class I equipment	Ultrasound system powered from power supply or part of the Mobile Docking System
Internally powered equipment	Ultrasound system not connected to the power supply (battery only)
Type BF applied parts	Ultrasound transducers
Type CF applied parts	ECG module/ECG leads
IPX-7 (watertight equipment)	Ultrasound transducers
IPX-8 (watertight equipment)	Footswitch
Non AP/APG	Ultrasound system power supply, Mobile Docking System, and peripherals. Equipment is not suitable for use in the presence of flammable anaesthetics.

Electrical safety

This system meets EN60601-1, Class I/internally-powered equipment requirements and Type BF isolated patient-applied parts safety requirements.

This system complies with the applicable medical equipment requirements published in the Canadian Standards Association (CSA), European Norm Harmonized Standards, and Underwriters Laboratories (UL) safety standards. See [Chapter 8, "Specifications."](#)

For maximum safety observe the following warnings and cautions.

- WARNING:** To avoid discomfort or minor risk of patient injury, keep hot surfaces away from the patient.
- Under certain circumstances, the transducer connector and back of the display enclosure can reach temperatures that exceed EN60601-1 limits for patient contact, therefore only the operator shall handle the system. This does not include the transducer face.
- To avoid discomfort or minor risk of operator injury when handling the transducer connector, the system should not be operated for more than 60 minutes continuously in a live-scan mode (as opposed to freeze or sleep modes).
- To avoid the risk of electrical shock or injury, do not open the system enclosures. All internal adjustments and replacements, except battery replacement, must be made by a qualified technician.
- To avoid the risk of injury, do not operate the system in the presence of flammable gasses or anesthetics. Explosion can result.
- To avoid the risk of electrical shock, use only properly grounded equipment. Shock hazards exist if the power supply is not properly grounded. Grounding reliability can only be achieved when equipment is connected to a receptacle marked "Hospital Only" or "Hospital Grade" or the equivalent. The grounding wire must not be removed or defeated.
- To avoid the risk of electrical shock, when using the system in an environment where the integrity of the protective earth conductor arrangement is in doubt, operate the system on battery power only without using the power supply.
- To avoid the risk of electrical shock, do not connect the system's power supply or a docking system to an MPSO or extension cord.
- To avoid the risk of electrical shock, before using the transducer, inspect the transducer face, housing, and cable. Do not use the transducer if the transducer or cable is damaged.
- To avoid the risk of electrical shock, always disconnect the power supply from the system before cleaning the system.
- To avoid the risk of electrical shock, do not use any transducer that has been immersed beyond the specified cleaning or disinfection level. See [Chapter 5, "Troubleshooting and Maintenance."](#)
- To avoid the risk of electrical shock and fire hazard, inspect the power supply, AC power cord, and plug on a regular basis. Ensure they are not damaged.

To avoid the risk of electrical shock and fire hazard, the power cord set that connects the power supply of the ultrasound system or MDS to mains power must only be used with the power supply or MDS, and cannot be used to connect other devices to mains power.

To avoid the risk of electrical shock, use only accessories and peripherals recommended by SonoSite, including the power supply. Connection of accessories and peripherals not recommended by SonoSite could result in electrical shock. Contact SonoSite or your local representative for a list of accessories and peripherals available from or recommend by SonoSite.

To avoid the risk of electrical shock, use commercial grade peripherals recommended by SonoSite on battery power only. Do not connect these products to AC mains power when using the system to scan or diagnose a patient/subject. Contact SonoSite or your local representative for a list of the commercial grade peripherals available from or recommended by SonoSite.

To avoid the risk of electrical shock, inspect cables and power cords used within the system on a regular basis for damage.

To avoid the risk of electrical shock to the patient/subject, do not touch the system battery contacts while simultaneously touching a patient/subject.

To prevent injury to the operator/bystander, the transducer must be removed from patient contact before the application of a high-voltage defibrillation pulse.

To avoid possible electrical shock or electromagnetic interference, verify proper operation and compliance with relevant safety standards for all equipment before clinical use. Connecting additional equipment to the ultrasound system constitutes configuring a medical system. SonoSite recommends verifying that the system, all combinations of equipment, and accessories connected to the ultrasound system comply with JACHO installation requirements and/or safety standards such as AAMI-ES1, NFPA 99 OR IEC Standard 60601-1-1 and electromagnetic compatibility standard IEC 60601-1-2 (Electromagnetic compatibility), and are certified according to IEC Standard 60950 (Information Technology Equipment (ITE)).

Caution:

Do not use the system if an error message appears on the image display: note the error code; call SonoSite or your local representative; turn off the system by pressing and holding the power key until the system powers down.

To avoid increasing the system and transducer connector temperature, do not block the airflow to the ventilation holes on the side of the system.

Equipment safety

To protect your ultrasound system, transducer, and accessories, follow these precautions.

- Caution:**
- Excessive bending or twisting of cables can cause a failure or intermittent operation.
 - Improper cleaning or disinfecting of any part of the system can cause permanent damage. For cleaning and disinfecting instructions, see [Chapter 5, "Troubleshooting and Maintenance."](#)
 - Do not submerge the transducer connector in solution. The cable is not liquid-tight beyond the transducer connector/cable interface.
 - Do not use solvents such as thinner or benzene, or abrasive cleaners on any part of the system.
 - Remove the battery from the system if the system is not likely to be used for some time.
 - Do not spill liquid on the system.

Battery safety

To prevent the battery from bursting, igniting, or emitting fumes and causing personal injury or equipment damage, observe the following precautions.

- WARNING:**
- The battery has a safety device. Do not disassemble or alter the battery.
 - Charge the batteries only when the ambient temperature is between 0° and 40°C (32° and 104°F).
 - Do not short-circuit the battery by directly connecting the positive and negative terminals with metal objects.
 - Do not heat the battery or discard it in a fire.
 - Do not expose the battery to temperatures over 60°C (140°F). Keep it away from fire and other heat sources.
 - Do not charge the battery near a heat source, such as a fire or heater.
 - Do not leave the battery in direct sunlight.
 - Do not pierce the battery with a sharp object, hit it, or step on it.
 - Do not use a damaged battery.
 - Do not solder a battery.
 - The polarity of the battery terminals are fixed and cannot be switched or reversed. Do not force the battery into the system.
 - Do not connect the battery to an electrical power outlet.

WARNING: Do not continue recharging the battery if it does not recharge after two successive six hour charging cycles.

If the battery leaks or emits an odor, remove it from all possible flammable sources.

Caution: To avoid the battery bursting, igniting, or emitting fumes from the battery and causing equipment damage, observe the following precautions:

Do not immerse the battery in water or allow it to get wet.

Do not put the battery into a microwave oven or pressurized container.

If the battery emits an odor or heat, is deformed or discolored, or in any way appears abnormal during use, recharging or storage, immediately remove it and stop using it. If you have any questions about the battery, consult SonoSite or your local representative.

Store the battery between -20°C (-4°F) and 60°C (140°F).

Use only SonoSite batteries.

Do not use or charge the battery with non-SonoSite equipment. Only charge the battery with the system.

Biological safety

Observe the following precautions related to biological safety.

WARNING: To avoid device damage or patient injury, do not use the P10/P17 needle guide bracket on patients with pacemakers or medical electronic implants. The needle guide bracket for the P10 and P17 transducers contains a magnet that is used to ensure the bracket is correctly oriented on the transducer. The magnetic field in direct proximity to the pacemaker or medical electronic implant may have an adverse effect.

Non-medical (commercial) grade peripheral monitors have not been verified or validated by SonoSite as being suitable for diagnosis.

To avoid the risk of a burn hazard, do not use the transducer with high frequency surgical equipment. Such a hazard may occur in the event of a defect in the high frequency surgical neutral electrode connection.

Do not use the system if it exhibits erratic or inconsistent behavior. Discontinuities in the scanning sequence are indicative of a hardware failure that must be corrected before use.

Some transducer sheaths contain natural rubber latex and talc, which can cause allergic reactions in some individuals. Refer to 21 CFR 801.437, User labeling for devices that contain natural rubber.

WARNING: Perform ultrasound procedures prudently. Use the ALARA (as low as reasonably achievable) principle and follow the prudent use information concerning MI and TI.

SonoSite does not currently recommend a specific brand of acoustic standoff. If an acoustic standoff is used, it must have a minimum attenuation of .3dB/cm/MHz.

Some SonoSite transducers are approved for intraoperative applications if a market-cleared sheath is used.

Electromagnetic compatibility

The ultrasound system has been tested and found to comply with the electromagnetic compatibility (EMC) limits for medical devices to IEC 60601-1-2:2001. These limits are designed to provide reasonable protection against harmful interference in a typical medical installation.

Caution: Medical electrical equipment requires special precautions regarding EMC and must be installed and operated according to these instructions. It is possible that high levels of radiated or conducted radio-frequency electromagnetic interference (EMI) from portable and mobile RF communications equipment or other strong or nearby radio-frequency sources, could result in performance disruption of the ultrasound system. Evidence of disruption may include image degradation or distortion, erratic readings, equipment ceasing to operate, or other incorrect functioning. If this occurs, survey the site to determine the source of disruption, and take the following actions to eliminate the source(s).

- Turn equipment in the vicinity off and on to isolate disruptive equipment.
- Relocate or re-orient interfering equipment.
- Increase distance between interfering equipment and your ultrasound system.
- Manage use of frequencies close to ultrasound system frequencies.
- Remove devices that are highly susceptible to EMI.
- Lower power from internal sources within facility control (such as paging systems).
- Label devices susceptible to EMI.
- Educate clinical staff to recognize potential EMI-related problems.
- Eliminate or reduce EMI with technical solutions (such as shielding).
- Restrict use of personal communicators (cell phones, computers) in areas with devices susceptible to EMI.
- Share relevant EMI information with others, particularly when evaluating new equipment purchases which may generate EMI.
- Purchase medical devices that comply with IEC 60601-1-2 EMC Standards.

Caution:

To avoid the risk of increased electromagnetic emissions or decreased immunity, use only accessories and peripherals recommended by SonoSite. Connection of accessories and peripherals not recommended by SonoSite could result in malfunctioning of your ultrasound system or other medical electrical devices in the area. Contact SonoSite or your local representative for a list of accessories and peripherals available from or recommended by SonoSite. See the SonoSite accessories user guide.

Electrostatic discharge (ESD), or static shock, is a naturally occurring phenomenon. ESD is common in conditions of low humidity, which can be caused by heating or air conditioning. Static shock is a discharge of the electrical energy from a charged body to a lesser or non-charged body. The degree of discharge can be significant enough to cause damage to a transducer or an ultrasound system. The following precautions can help reduce ESD: anti-static spray on carpets, anti-static spray on linoleum, and anti-static mats.

Manufacturer's declaration

Table 1 and Table 2 document the intended use environment and EMC compliance levels of the system. For maximum performance, ensure that the system is used in the environments described in this table.

The system is intended for use in the electromagnetic environment specified below.

Table 1: Manufacturer's Declaration - Electromagnetic Emissions

Emissions Test	Compliance	Electromagnetic Environment
RF emissions CISPR 11	Group 1	The SonoSite ultrasound system uses RF energy only for its internal function. Therefore, its RF emissions are very low and are not likely to cause any interference in nearby electronic equipment.
RF emissions CISPR 11	Class A	The SonoSite ultrasound system is suitable for use in all establishments other than domestic and those directly connected to the public low-voltage power supply network which supplies buildings used for domestic purposes.
Harmonic emissions IEC 61000-3-2	Class A	
Voltage fluctuations/ flicker emissions IEC 61000-3-3	Complies	

The system is intended for use in the electromagnetic environment specified below.

Table 2: Manufacturer's Declaration - Electromagnetic Immunity

Immunity Test	IEC 60601 Test Level	Compliance Level	Electromagnetic Environment
Electrostatic Discharge (ESD) IEC 61000-4-2	2.0KV, 4.0KV, 6.0KV contact 2.0KV, 4.0KV, 8.0KV air	2.0KV, 4.0KV, 6.0KV contact 2.0KV, 4.0KV, 8.0KV air	Floors should be wood, concrete or ceramic tile. If floors are covered with synthetic material, the relative humidity should be at least 30%.
Electrical fast Transient burst IEC 61000-4-4	2KV on the mains 1KV on signal lines	2KV on the mains 1KV on signal lines	Mains power quality should be that of a typical commercial or hospital environment.
Surge IEC 61000-4-5	0.5KV, 1.0KV, 2.0KV on AC power lines to ground 0.5KV, 1.0KV on AC power lines to lines	0.5KV, 1.0KV, 2.0KV on AC power lines to ground 0.5KV, 1.0KV on AC power lines to lines	Mains power quality should be that of a typical commercial or hospital environment.
Voltage dips, short interruptions and voltage variations on power supply input lines IEC 61000-4-11	>5% U_T (>95% dip in U_T) for 0.5 cycle 40% U_T (60% dip in U_T) for 5 cycles 70% U_T (30% dip in U_T) for 25 cycles >5% U_T (>95% dip in U_T) for 5s	>5% U_T (>95% dip in U_T) for 0.5 cycle 40% U_T (60% dip in U_T) for 5 cycles 70% U_T (30% dip in U_T) for 25 cycles >5% U_T (>95% dip in U_T) for 5s	Mains power quality should be that of a typical commercial or hospital environment. If the user of the SonoSite ultrasound system requires continued operation during power mains interruptions, it is recommended that the SonoSite ultrasound system be powered from an uninterruptible power supply or a battery.

Table 2: Manufacturer's Declaration - Electromagnetic Immunity (Continued)

Immunity Test	IEC 60601 Test Level	Compliance Level	Electromagnetic Environment
Power Frequency Magnetic Field IEC 61000-4-8	3 A/m	3 A/m	If image distortion occurs, it may be necessary to position the SonoSite ultrasound system further from sources of power frequency magnetic fields or to install magnetic shielding. The power frequency magnetic field should be measured in the Intended installation location to assure that it is sufficiently low.
Conducted RF IEC 61000-4-6	3 Vrms 150 kHz to 80 MHz	3 Vrms	Portable and mobile RF communications equipment should be used no closer to any part of the SonoSite ultrasound system including cables, than the recommended separation distance calculated from the equation applicable to the frequency of the transmitter. Recommended Separation Distance $d = 1.2 \sqrt{P}$
Radiated RF IEC 61000-4-3	3 Vm 80 MHz to 2.5 GHz	3 V/m	$d = 1.2 \sqrt{P}$ 80 MHz to 800 MHz $d = 2.3 \sqrt{P}$ 800 MHz to 2,5 GHz Where P is the maximum output power rating of the transmitter in watts (W) according to the transmitter manufacturer and d is the recommended separation distance in meters (m).

Table 2: Manufacturer’s Declaration - Electromagnetic Immunity (Continued)

Immunity Test	IEC 60601 Test Level	Compliance Level	Electromagnetic Environment
Radiated RF IEC 61000-4-3 (continued)			<p>Field strengths from fixed RF transmitters, as determined by an electromagnetic Site survey^a, should be less than the compliance level in each frequency range^b.</p> <p>Interference may occur in the vicinity of equipment marked with the following symbol:</p>  <p>(IEC 60417 No. 417-IEC-5140: “Source of non-ionizing radiation”)</p>

*Note: U_T is the AC mains voltage prior to application of the test level.
At 80 MHz and 800 MHz, the higher frequency range applies.
These guidelines may not apply in all situations. Electromagnetic propagation is affected by absorption and reflection from structures, objects and people.*

- a. Field strengths from fixed transmitters such as base stations for radio (cellular/cordless) telephones and land mobile radios, amateur radio, AM and FM radio broadcast and TV broadcast cannot be predicted theoretically with accuracy. To assess the electromagnetic environment due to fixed RF transmitters, an electromagnetic site survey should be considered. If the measured field strength in the location in which the SonoSite ultrasound system is used exceeds the applicable RF compliance level above, the SonoSite ultrasound system should be observed to verify normal operation. If abnormal performance is observed, additional measures may be necessary, such as re-orienting or relocating the SonoSite ultrasound system.
- b. Over the frequency range 150 kHz to 80 MHz, field strengths should be less than 3 V/m.

ALARA principle

ALARA is the guiding principle for the use of diagnostic ultrasound. Sonographers and other qualified ultrasound users, using good judgment and insight, determine the exposure that is “as low as reasonably achievable.” There are no set rules to determine the correct exposure for every situation. The qualified ultrasound user determines the most appropriate way to keep exposure low and bioeffects to a minimum, while obtaining a diagnostic examination.

A thorough knowledge of the imaging modes, transducer capability, system setup and scanning technique is necessary. The imaging mode determines the nature of the ultrasound beam. A stationary beam results in a more concentrated exposure than a scanned beam, which spreads that exposure over that area. The transducer capability depends upon the frequency,

penetration, resolution, and field of view. The default system presets are reset at the start of each new patient. It is the scanning technique of the qualified ultrasound user along with patient variability that determines the system settings throughout the exam.

The variables which affect the way the qualified ultrasound user implements the ALARA principle include: patient body size, location of the bone relative to the focal point, attenuation in the body, and ultrasound exposure time. Exposure time is an especially useful variable, because the qualified ultrasound user can control it. The ability to limit the exposure over time supports the ALARA principle.

Applying ALARA

The system imaging mode selected by the qualified ultrasound user is determined by the diagnostic information required. 2D imaging provides anatomical information; CPD imaging provides information about the energy or amplitude strength of the Doppler signal over time at a given anatomical location and is used for detecting the presence of blood flow; Color imaging provides information about the energy or amplitude strength of the Doppler signal over time at a given anatomical location and is used for detecting the presence, velocity, and direction of blood flow; Tissue Harmonic Imaging uses higher received frequencies to reduce clutter, artifact, and improve resolution on the 2D image. Understanding the nature of the imaging mode used allows the qualified ultrasound user to apply the ALARA principle.

Prudent use of ultrasound requires that patient exposure to ultrasound be limited to the lowest ultrasound output for the shortest time necessary to achieve acceptable diagnostic results. Decisions that support prudent use are based on the type of patient, exam type, patient history, ease or difficulty of obtaining diagnostically useful information, and potential localized heating of the patient due to transducer surface temperature.

The system has been designed to ensure that temperature at the face of the transducer will not exceed the limits established in Section 42 of EN 60601-2-37: Particular requirement for the safety of ultrasound medical diagnostic and monitoring equipment. See “[Transducer surface temperature rise](#)” on page 128. In the event of a device malfunction, there are redundant controls that limit transducer power. This is accomplished by an electrical design that limits both power supply current and voltage to the transducer.

The sonographer uses the system controls to adjust image quality and limit ultrasound output. The system controls are divided into three categories relative to output: controls that directly affect output, controls that indirectly affect output, and receiver controls.

Direct controls

The system does not exceed a spatial peak temporal average intensity (ISPTA) of 720 mW/cm² for all imaging modes. (For ophthalmic use the Orb exam mode is limited to the following values: ISPTA does not exceed 50 mW/cm²; TI does not exceed 1.0, and MI does not exceed 0.23.) The mechanical index (MI) and thermal index (TI) may exceed values greater than 1.0 on some transducers in some imaging modes. One may monitor the MI and TI values and adjust the controls to reduce these values. See “[Guidelines for reducing MI and TI](#)” on page 124.

Additionally, one means for meeting the ALARA principle is to set the MI or TI values to a low index value and then modifying this level until a satisfactory image or Doppler mode is obtained. For more information on MI and TI, see BS EN 60601-2-37:2001: Annex HH.

Indirect controls

The controls that indirectly affect output are controls affecting imaging mode, freeze, and depth. The imaging mode determines the nature of the ultrasound beam. Tissue attenuation is directly related to transducer frequency. The higher the PRF (pulse repetition frequency), the more output pulses occur over a period of time.

Receiver controls

The receiver controls are the gain controls. Receiver controls do not affect output. They should be used, if possible, to improve image quality before using controls that directly or indirectly affect output.

Acoustic artifacts

An acoustic artifact is information, present or absent in an image, that does not properly indicate the structure or flow being imaged. There are helpful artifacts that aid in diagnosis and those that hinder proper interpretation. Examples of artifacts include:

- Shadowing
- Through transmission
- Aliasing
- Reverberations
- Comet tails

For more information on detecting and interpreting acoustic artifacts, see the following reference:

Kremkau, Frederick W. *Diagnostic Ultrasound: Principles and Instruments*. 7th ed., W.B. Saunders Company, (Oct. 17, 2005).

Guidelines for reducing MI and TI

The following are general guidelines for reducing MI or TI. If multiple parameters are given, then the best results may be achieved by minimizing these parameters simultaneously. In some modes changing these parameters will not affect MI or TI. Changes to other parameters may also result in MI and TI reductions. Please note the 'MI' or 'TI' read out on the right side of the LCD screen.

“↓” means to decrease or lower setting of parameter to reduce MI or TI.

“↑” means to raise or increase setting of parameter to reduce MI or TI

Table 3: MI

Transducer	Depth
C11x	↑
C60x	↑
HFL38x	↑
ICTx	↑
L25x	↑
L38x	↑
P21x	↑

Table 4: TI (TIS, TIC, TIB)

Transducer	Color Power Doppler Settings					Optimize	PW Settings
	Box Width	Box Height	Box Depth	PRF	Depth		
C11x			↑	↓	↑		↓ (Depth)
C60x	↓		↑	↓	↑		↓ (PRF)
HFL38x			↑	↑	↑		↓ (Depth)
ICTx		↑	↑	↓		Exam Gyn	↓ (PRF)
L25x	↓				↑		↓ (PRF)
L38x				↓			↓ (Depth)
P21x		↓		↓	↑		↓ (PRF)

Output display

The system meets the AIUM output display standard for MI and TI (see last reference listed in “[Related guidance documents](#)” below). Table 5 indicates for each transducer and operating mode when either the TI or MI is greater than or equal to a value of 1.0, thus requiring display.

Table 5: Cases Where Either a Thermal or Mechanical Index is ≥ 1.0

Transducer Model	Index	2D/ M Mode	CPD/ Color	PW Doppler	CW Doppler
C11x/8-5	MI	No	No	No	—
	TIC, TIB, or TIS	No	Yes	Yes	—
C60x/5-2	MI	Yes	No	No	—
	TIC, TIB, or TIS	No	No	Yes	—
HFL38x/13-6	MI	No	Yes	No	—
	TIC, TIB, or TIS	No	Yes	Yes	—
ICTx/8-5	MI	No	No	No	—
	TIC, TIB, or TIS	No	No	Yes	—
L25x/13-6	MI	No	No	No	—
	TIC, TIB, or TIS	No	No	Yes	—
L38x/10-5	MI	No	Yes	Yes	—
	TIC, TIB, or TIS	No	Yes	Yes	—
P21x/5-1	MI	Yes	Yes	Yes	No
	TIC, TIB, or TIS	Yes	Yes	Yes	Yes

Even when MI is less than 1.0, the system provides a continuous real-time display of MI whenever a transducer is operated in a 2D imaging mode. The index is displayed in increments of 0.1.

The system meets the output display standard for TI. A continuous real-time display of TI is provided for the operator whenever a transducer is operated in a CPD, Color, M Mode, or PW Doppler imaging mode. The index is displayed in increments of 0.1.

The thermal index consists of three user selectable indices, and only one of these is displayed at any one time. In order to display properly and meet the ALARA principle, the user selects an appropriate TI based on the specific exam being performed. SonoSite provides the AIUM Medical Ultrasound Safety reference which contains guidance on how to determine which TI is appropriate (see second reference listed in “[Related guidance documents](#)” on page 127).

Mechanical and thermal indices output display accuracy

The accuracy result for the mechanical index (MI) is stated statistically. With 90% confidence, 90% of the measured MI values will be within +16% to -31% of the displayed MI value, or +0.2 of the displayed value, whichever value is larger.

The accuracy result for the thermal index (TI) is stated statistically. With 90% confidence, 90% of the measured TI values will be within +26% to -50% of the displayed TI value, or +0.2 of the displayed value, whichever value is larger. The values equate to +1dB to -3dB.

A displayed value of 0.0 for MI or TI means that the calculated estimate for the index is less than 0.05.

Factors that contribute to display uncertainty

The net uncertainty of the displayed indices is derived by combining the quantified uncertainty from three sources; measurement uncertainty, system and transducer variability, and engineering assumptions and approximations made when calculating the display values.

Measurement errors of the acoustic parameters when taking the reference data are the major source of error that contributes to the display uncertainty. The measurement error is described in [“Acoustic measurement precision and uncertainty”](#) on page 149.

The displayed MI and TI values are based on calculations that use a set of acoustic output measurements that were made using a single reference ultrasound system with a single reference transducer that is representative of the population of transducers of that type. The reference system and transducer are chosen from a sample population of systems and transducers taken from early production units, and they are selected based on having an acoustic output that is representative of the nominal expected acoustic output for all transducer/system combinations that might occur. Of course every transducer/system combination has its own unique characteristic acoustic output, and will not match the nominal output on which the display estimates are based. This variability between systems and transducers introduces an error into displayed value. By doing acoustic output sampling testing during production, the amount of error introduced by the variability is bounded. The sampling testing ensures that the acoustic output of transducers and systems being manufactured stays within a specified range of the nominal acoustic output.

Another source of error arises from the assumptions and approximations that are made when deriving the estimates for the display indices. Chief among these assumptions is that the acoustic output, and thus the derived display indices, are linearly correlated with the transmit drive voltage of the transducer. Generally, this assumption is very good, but it is not exact, and thus some error in the display can be attributed to the assumption of voltage linearity.

Related guidance documents

- Information for Manufacturers Seeking Marketing Clearance of Diagnostic Ultrasound Systems and Transducers, FDA, 1997.
- Medical Ultrasound Safety, American Institute of Ultrasound in Medicine (AIUM), 1994. (A copy is included with each system.)

- Acoustic Output Measurement Standard for Diagnostic Ultrasound Equipment, NEMA UD2-2004.
- Acoustic Output Measurement and Labeling Standard for Diagnostic Ultrasound Equipment, American Institute of Ultrasound in Medicine, 1993.
- Standard for Real-Time Display of Thermal and Mechanical Acoustic Output Indices on Diagnostic Ultrasound Equipment, NEMA UD3-2004.
- Guidance on the interpretation of TI and MI to be used to inform the operator, Annex HH, BS EN 60601-2-37 reprinted at P05699.

Transducer surface temperature rise

Table 6 and Table 7 list the measured surface temperature rise from ambient* of transducers used on the ultrasound system. The temperatures were measured in accordance with EN 60601-2-37 section 42 where controls and settings were positioned to give maximum temperatures

Test 1: The transducer surface temperature test on tissue mimicking material (TMM) is based on the following standard: 42.3(a) 1, Test Method B (IEC 60601-2-37, Amendment 1). The limit is a 10°C rise from ambient, as measured on the TMM.

Test 2: The transducer surface temperature test in air is based on the following standard: 42.3(a) 2 (IEC 60601-2-37, Amendment 1). The limit is a 27°C rise from ambient.

Test 3: The transducer surface temperature test on TMM is based on the following standard: 42.3(a) 1, Test Method B (IEC 60601-2-37, Amendment 1). The limit is a 6°C rise from ambient, as measured on the TMM.

*The ambient temperature shall be 23°C ± 3°C.

Table 6: Transducer Surface Temperature Rise EN 60601-2-37 (External Use)

Test	C11x	C60x	HFL38x	L25x	L38x	P21x
1	9.2°C	9.0°C	9.5°C	9.5°C	9.6°C	9.0°C
2	19.0°C	18.0°C	19.0°C	18.2°C	20.0°C	20.0°C

Table 7: Transducer Surface Temperature Rise IEC 60601-2-37 (Internal Use)

Test	ICTx
3	5.5°C
2	12.0°C

Acoustic output measurement

Since the initial use of diagnostic ultrasound, the possible human biological effects (bioeffects) from ultrasound exposure have been studied by various scientific and medical institutions. In October 1987, the American Institute of Ultrasound in Medicine (AIUM) ratified a report prepared by its Bioeffects Committee (Bioeffects Considerations for the Safety of Diagnostic Ultrasound, *J Ultrasound Med.*, Sept. 1988: Vol. 7, No. 9 Supplement), sometimes referred to as the Stowe Report, which reviewed available data on possible effects of ultrasound exposure. Another report “Bioeffects and Safety of Diagnostic Ultrasound,” dated January 28, 1993 provides more current information.

The acoustic output for this ultrasound system has been measured and calculated in accordance with the “Acoustic Output Measurement Standard for Diagnostic Ultrasound Equipment” (NEMA UD2-2004), and the “Standard for Real-Time Display of Thermal and Mechanical Acoustic Output Indices on Diagnostic Ultrasound Equipment” (NEMA UDe3-2004).

In Situ, derated, and water value intensities

All intensity parameters are measured in water. Since water does not absorb acoustic energy, these water measurements represent a worst case value. Biological tissue does absorb acoustic energy. The true value of the intensity at any point depends on the amount, type of tissue, and the frequency of the ultrasound passing through the tissue. The intensity value in the tissue, *In Situ*, has been estimated by using the following formula:

$$In\ Situ = Water [e^{-(0.23alf)}]$$

where:

In Situ = *In Situ* intensity value

Water = Water intensity value

e = 2.7183

a = attenuation factor (dB/cm MHz)

Attenuation factor (a) for various tissue types are given below:

brain = 0.53

heart = 0.66

kidney = 0.79

liver = 0.43

muscle = 0.55

l = skinline to measurement depth in cm

f = center frequency of the transducer/system/mode combination in MHz

Since the ultrasonic path during the exam is likely to pass through varying lengths and types of tissue, it is difficult to estimate the true *In Situ* intensity. An attenuation factor of 0.3 is used for general reporting purposes; therefore, the *In Situ* value commonly reported uses the formula:

$$In\ Situ\ (derated) = Water [e^{-(0.069If)}]$$

Since this value is not the true *In Situ* intensity, the term “derated” is used to qualify it.

The maximum derated and the maximum water values do not always occur at the same operating conditions; therefore, the reported maximum water and derated values may not be related by the *In Situ* (derated) formula. For example: a multi-zone array transducer that has maximum water value intensities in its deepest zone, but also has the smallest derating factor in that zone. The same transducer may have its largest derated intensity in one of its shallowest focal zones.

Tissue models and equipment survey

Tissue models are necessary to estimate attenuation and acoustic exposure levels *In Situ* from measurements of acoustic output made in water. Currently, available models may be limited in their accuracy because of varying tissue paths during diagnostic ultrasound exposures and uncertainties in the acoustic properties of soft tissues. No single tissue model is adequate for predicting exposures in all situations from measurements made in water, and continued improvement and verification of these models is necessary for making exposure assessments for specific exam types.

A homogeneous tissue model with attenuation coefficient of 0.3 dB/cm MHz throughout the beam path is commonly used when estimating exposure levels. The model is conservative in that it overestimates the *In Situ* acoustic exposure when the path between the transducer and site of interest is composed entirely of soft tissue. When the path contains significant amounts of fluid, as in many first and second-trimester pregnancies scanned transabdominally, this model may underestimate the *In Situ* acoustic exposure. The amount of underestimation depends upon each specific situation.

Fixed-path tissue models, in which soft tissue thickness is held constant, sometimes are used to estimate *In Situ* acoustic exposures when the beam path is longer than 3 cm and consists largely of fluid. When this model is used to estimate maximum exposure to the fetus during transabdominal scans, a value of 1 dB/cm MHz may be used during all trimesters.

Existing tissue models that are based on linear propagation may underestimate acoustic exposures when significant saturation due to non-linear distortion of beams in water is present during the output measurement.

The maximum acoustic output levels of diagnostic ultrasound devices extend over a broad range of values:

- A survey of 1990-equipment models yielded MI values between 0.1 and 1.0 at their highest output settings. Maximum MI values of approximately 2.0 are known to occur for currently available equipment. Maximum MI values are similar for real-time 2D and M Mode imaging.

- Computed estimates of upper limits to temperature elevations during transabdominal scans were obtained in a survey of 1988 and 1990 pulsed Doppler equipment. The vast majority of models yielded upper limits less than 1° and 4°C (1.8° and 7.2°F) for exposures of first-trimester fetal tissue and second-trimester fetal bone, respectively. The largest values obtained were approximately 1.5°C (2.7°F) for first-trimester fetal tissue and 7°C (12.6°F) for second-trimester fetal bone. Estimated maximum temperature elevations given here are for a “fixed path” tissue model and are for devices having I_{SPTA} values greater than 500 mW/cm². The temperature elevations for fetal bone and tissue were computed based on calculation procedures given in Sections 4.3.2.1-4.3.2.6 in “Bioeffects and Safety of Diagnostic Ultrasound” (AIUM, 1993).

Acoustic output tables

Table 8 through Table 23 indicate the acoustic output for the system and transducer combinations with a thermal index or mechanical index equal to or greater than one. These tables are organized by transducer model and imaging mode. For a definition of terms used in the tables, see “Terms used in the acoustic output tables” on page 148.

Table 8: Transducer Model: C11x/8-5

Operating Mode: CPD/Color

Index Label		M.I.	TIS		TIB	TIC		
			Scan	Non-scan			Non-scan	
				A _{aprt} ≤1	A _{aprt} >1			
Global Maximum Index Value		(a)	(a)	—	—	1.2		
Associated Acoustic Parameter	p _{r,3} (MPa)	#						
	W ₀ (mW)		#	—		40.50		
	min of [W ₃ (z ₁), I _{TA,3} (z ₁)] (mW)				—			
	z ₁ (cm)				—			
	z _{bp} (cm)				—			
	z _{sp} (cm)	#				—		
	d _{eq} (z _{sp}) (cm)					—		
	f _c (MHz)	#	#	—	—	—	4.38	
	Dim of A _{aprt}	X (cm)		#	—	—	—	0.36
Y (cm)			#	—	—	—	0.5	
Other Information	PD (μsec)	#						
	PRF (Hz)	#						
	p _r @PII _{max} (MPa)	#						
	d _{eq} @PII _{max} (cm)					—		
	Focal Length	FL _x (cm)		#	—	—	—	1.56
		FL _y (cm)		#	—	—	—	2.5
I _{PA,3} @MI _{max} (W/cm ²)	#							
Operating Control Conditions	Control 1: Mode						CPD	
	Control 2: Exam Type						Vas	
	Control 3: PRF						2841	
	Control 4: Optimization/Depth						Med/2.0	
	Control 5: Color Box Position/ Size						Top/ Short	

(a) This index is not required for this operating mode; value is <1.

(b) This transducer is not intended for transcranial or neonatal cephalic uses.

#No data are reported for this operating condition since the global maximum index value is not reported for the reason listed. (Reference Global Maximum Index Value line.)

— Data are not applicable for this transducer/mode.

Table 9: Transducer Model: C11x/8-5

Operating Mode: PW Doppler

Index Label		M.I.	TIS			TIB	TIC	
			Scan	Non-scan		Non-scan		
				$A_{aprt} \leq 1$	$A_{aprt} > 1$			
Global Maximum Index Value		(a)	—	(a)	—	1.8	1.7	
Associated Acoustic Parameter	$p_{r,3}$ (MPa)	#						
	W_0 (mW)		—	#		26.29	24.65	
	min of [$W_{.3}(z_1), I_{TA,3}(z_1)$] (mW)				—			
	z_1 (cm)				—			
	z_{bp} (cm)				—			
	z_{sp} (cm)	#				1.1		
	$d_{eq}(z_{sp})$ (cm)					0.236		
	f_c (MHz)	#	—	#	—	4.36	4.36	
	Dim of A_{aprt}	X (cm)		—	#	—	0.28	0.2
Y (cm)			—	#	—	0.5	0.5	
Other Information	PD (μ sec)	#						
	PRF (Hz)	#						
	$p_r@PII_{max}$ (MPa)	#						
	$d_{eq}@PII_{max}$ (cm)					0.226		
	Focal Length	FL _x (cm)		—	#	—		0.77
		FL _y (cm)		—	#	—		2.5
$I_{PA,3}@MI_{max}$ (W/cm ²)	#							
Operating Control Conditions	Control 1: Exam Type					Any	Any	
	Control 2: Sample Volume					2 mm	3 mm	
	Control 3: PRF					3906	≥ 3906	
	Control 4: Sample Volume Position					Zone 1	Zone 0	

(a) This index is not required for this operating mode; value is <1.

(b) This transducer is not intended for transcranial or neonatal cephalic uses.

#No data are reported for this operating condition since the global maximum index value is not reported for the reason listed. (Reference Global Maximum Index Value line.)

— Data are not applicable for this transducer/mode.

Table 10: Transducer Model: C60x/5-2

Operating Mode: 2D

Index Label		M.I.	TIS		TIB	TIC	
			Scan	Non-scan			Non-scan
				A _{aprt} ≤1	A _{aprt} >1		
Global Maximum Index Value		1.0	(a)	—	—	(b)	
Associated Acoustic Parameter	p _{r,3} (MPa)	1.59					
	W ₀ (mW)		#	—	—	#	
	min of [W ₃ (z ₁), I _{TA,3} (z ₁)] (mW)				—		
	z ₁ (cm)				—		
	z _{bp} (cm)				—		
	z _{sp} (cm)	5.3			—		
	d _{eq} (z _{sp}) (cm)				—		
	f _c (MHz)	2.86	#	—	—	—	#
	Dim of A _{aprt}	X (cm)		#	—	—	—
Y (cm)			#	—	—	—	#
Other Information	PD (μsec)	0.579					
	PRF (Hz)	7923					
	p _r @PII _{max} (MPa)	2.679					
	d _{eq} @PII _{max} (cm)				—		
	Focal Length	FL _x (cm)		#	—	—	#
		FL _y (cm)		#	—	—	#
I _{PA,3} @MI _{max} (W/cm ²)	197.7						
Operating Control Conditions	Control 1: Exam Type		Any				
	Control 2: Optimization		Pen				
	Control 3: Depth		6.6 cm				
	Control 4: THI		On				

(a) This index is not required for this operating mode; value is <1.

(b) This transducer is not intended for transcranial or neonatal cephalic uses.

#No data are reported for this operating condition since the global maximum index value is not reported for the reason listed. (Reference Global Maximum Index Value line.)

— Data are not applicable for this transducer/mode.

Table 11: Transducer Model: C60x/5-2

Operating Mode: M Mode

Index Label		M.I.	TIS		TIB	TIC		
			Scan	Non-scan			Non-scan	
				$A_{aprt} \leq 1$	$A_{aprt} > 1$			
Global Maximum Index Value		1.0	—	(a)	—	(a)	(b)	
Associated Acoustic Parameter	$p_{r,3}$ (MPa)	1.62						
	W_0 (mW)		—	#		#	#	
	min of [$W_{.3}(z_1), I_{TA,3}(z_1)$] (mW)				—			
	z_1 (cm)				—			
	z_{bp} (cm)				—			
	z_{sp} (cm)	4.7				#		
	$d_{eq}(z_{sp})$ (cm)					#		
	f_c (MHz)	2.85	—	#	—	#	#	
	Dim of A_{aprt}	X (cm)		—	#	—	#	#
Y (cm)			—	#	—	#	#	
Other Information	PD (μ sec)	0.577						
	PRF (Hz)	800						
	$p_r@PII_{max}$ (MPa)	2.576						
	$d_{eq}@PII_{max}$ (cm)					#		
	Focal Length	FL _x (cm)		—	#	—		#
		FL _y (cm)		—	#	—		#
$I_{PA,3}@MI_{max}$ (W/cm ²)	184.3							
Operating Control Conditions	Control 1: Exam Type		Any					
	Control 2: Optimization		Pen					
	Control 3: Depth		7.8 cm					
	Control 4: MB (Multi Beam)		Off or On					

(a) This index is not required for this operating mode; value is <1.

(b) This transducer is not intended for transcranial or neonatal cephalic uses.

#No data are reported for this operating condition since the global maximum index value is not reported for the reason listed. (Reference Global Maximum Index Value line.)

— Data are not applicable for this transducer/mode.

Table 12: Transducer Model: C60x/5-2

Operating Mode: PW Doppler

Index Label		M.I.	TIS			TIB	TIC	
			Scan	Non-scan		Non-scan		
				A _{aprt} ≤1	A _{aprt} >1			
Global Maximum Index Value		(a)	—	(a)	—	3.1	(b)	
Associated Acoustic Parameter	p _{r,3} (MPa)	#						
	W ₀ (mW)		—	#		85.64	#	
	min of [W _{.3} (z ₁), I _{TA,3} (z ₁)] (mW)				—			
	z ₁ (cm)				—			
	z _{bp} (cm)				—			
	z _{sp} (cm)	#				1.255		
	d _{eq} (z _{sp}) (cm)					0.51		
	f _c (MHz)	#	—	#	—	2.233	#	
	Dim of A _{aprt}	X (cm)		—	#	—	0.6552	#
Y (cm)			—	#	—	1.3	#	
Other Information	PD (μsec)	#						
	PRF (Hz)	#						
	p _r @PII _{max} (MPa)	#						
	d _{eq} @PII _{max} (cm)					0.415		
	Focal Length	FL _x (cm)		—	#	—		#
		FL _y (cm)		—	#	—		#
I _{PA,3} @MI _{max} (W/cm ²)	#							
Operating Control Conditions	Control 1: Exam Type					Abd		
	Control 2: PRF					Any		
	Control 3: Sample Volume					12 mm		
	Control 4: Sample Volume Position					Zone 1		

(a) This index is not required for this operating mode; value is <1.

(b) This transducer is not intended for transcranial or neonatal cephalic uses.

#No data are reported for this operating condition since the global maximum index value is not reported for the reason listed. (Reference Global Maximum Index Value line.)

— Data are not applicable for this transducer/mode.

Table 13: Transducer Model: HFL38x/13-6

Operating Mode: CPD/Color

Index Label		M.I.	TIS		TIB	TIC		
			Scan	Non-scan			Non-scan	
				$A_{\text{aprt}} \leq 1$	$A_{\text{aprt}} > 1$			
Global Maximum Index Value		1.1	1.0	—	—	(b)		
Associated Acoustic Parameter	$p_{r,3}$ (MPa)	2.556						
	W_0 (mW)		53.49	—		#		
	min of [$W_{,3}(z_1), I_{TA,3}(z_1)$] (mW)				—			
	z_1 (cm)				—			
	z_{bp} (cm)				—			
	z_{sp} (cm)	1.2				—		
	$d_{eq}(z_{sp})$ (cm)					—		
	f_c (MHz)	5.328	5.324	—	—	—	#	
	Dim of A_{aprt}	X (cm)		0.44	—	—	—	#
Y (cm)			0.4	—	—	—	#	
Other Information	PD (μsec)	0.525						
	PRF (Hz)	2597						
	$p_r@PII_{\text{max}}$ (MPa)	3.187						
	$d_{eq}@PII_{\text{max}}$ (cm)					—		
	Focal Length	FL_x (cm)		1.32	—	—		#
		FL_y (cm)		2.5	—	—		#
$I_{PA,3}@MI_{\text{max}}$ (W/cm^2)	325.5							
Operating Control Conditions	Control 1: Mode	Color	Color					
	Control 2: Exam Type	Any	Any					
	Control 3: Optimization/Depth/PRF	Low/3.3 cm/ 393	Med/ 2.7 cm/ 1938					
	Control 4: Color Box Position/Size	Any	Top/ Short					

(a) This index is not required for this operating mode; value is <1.

(b) This transducer is not intended for transcranial or neonatal cephalic uses.

#No data are reported for this operating condition since the global maximum index value is not reported for the reason listed. (Reference Global Maximum Index Value line.)

— Data are not applicable for this transducer/mode.

Table 14: Transducer Model: HFL38x/13-6

Operating Mode: PW Doppler

Index Label		M.I.	TIS			TIB	TIC	
			Scan	Non-scan		Non-scan		
				$A_{aprt} \leq 1$	$A_{aprt} > 1$			
Global Maximum Index Value		(a)	—	1.2	—	2.2	(b)	
Associated Acoustic Parameter	$p_{r,3}$ (MPa)	#	—	—	—	—	—	
	W_0 (mW)	—	—	46.55	—	46.55	#	
	min of [$W_{.3}(z_1), I_{TA,3}(z_1)$]	—	—	—	—	—	—	
	z_1 (cm)	—	—	—	—	—	—	
	z_{bp} (cm)	—	—	—	—	—	—	
	z_{sp} (cm)	#	—	—	—	1.1	—	
	$d_{eq}(z_{sp})$ (cm)	—	—	—	—	0.33	—	
	f_c (MHz)	#	—	5.33	—	5.33	#	
	Dim of A_{aprt}	X (cm)	—	—	1.04	—	1.04	#
Y (cm)		—	—	0.4	—	0.4	#	
Other Information	PD (μ sec)	#	—	—	—	—	—	
	PRF (Hz)	#	—	—	—	—	—	
	$p_r@PII_{max}$ (MPa)	#	—	—	—	—	—	
	$d_{eq}@PII_{max}$ (cm)	—	—	—	—	0.46	—	
	Focal Length	FL_x (cm)	—	—	3.72	—	—	#
		FL_y (cm)	—	—	2.5	—	—	#
$I_{PA,3}@MI_{max}$ (W/cm^2)	#	—	—	—	—	—		
Operating Control Conditions	Control 1: Exam Type		—	Vas/Ven/IMT	—	Vas/Ven/IMT	—	
	Control 2: Sample Volume		—	12 mm	—	12 mm	—	
	Control 3: PRF		—	10417	—	10417	—	
	Control 4: Sample Volume Position		—	Zone 7	—	Zone 7	—	

(a) This index is not required for this operating mode; value is <1.

(b) This transducer is not intended for transcranial or neonatal cephalic uses.

#No data are reported for this operating condition since the global maximum index value is not reported for the reason listed. (Reference Global Maximum Index Value line.)

— Data are not applicable for this transducer/mode.

Table 15: Transducer Model: ICTx/8-5

Operating Mode: PW Doppler

Index Label		M.I.	TIS			TIB	TIC	
			Scan	Non-scan		Non-scan		
				$A_{aprt} \leq 1$	$A_{aprt} > 1$			
Global Maximum Index Value		(a)	—	(a)	—	1.2	(a)	
Associated Acoustic Parameter	$P_{r,3}$ (MPa)	#						
	W_0 (mW)		—	#		16.348	#	
	min of [$W_{,3}(z_1), I_{TA,3}(z_1)$] (mW)				—			
	z_1 (cm)				—			
	z_{bp} (cm)				—			
	z_{sp} (cm)	#				1.6		
	$d_{eq}(z_{sp})$ (cm)					0.192		
	f_c (MHz)	#	—	#	—	4.36	#	
	Dim of A_{aprt}	X (cm)		—	#	—	0.6	#
Y (cm)			—	#	—	0.5	#	
Other Information	PD (μ sec)	#						
	PRF (Hz)	#						
	$p_r@PII_{max}$ (MPa)	#						
	$d_{eq}@PII_{max}$ (cm)					0.187		
	Focal Length	FL_x (cm)		—	#	—		#
		FL_y (cm)		—	#	—		#
$I_{PA,3}@MI_{max}$ (W/cm^2)	#							
Operating Control Conditions	Control 1: Exam Type					Any		
	Control 2: Sample Volume					3 mm		
	Control 3: PRF					Any		
	Control 4: Sample Volume Position					Zone 1		

(a) This index is not required for this operating mode; value is <1.

(b) This transducer is not intended for transcranial or neonatal cephalic uses.

#No data are reported for this operating condition since the global maximum index value is not reported for the reason listed. (Reference Global Maximum Index Value line.)

— Data are not applicable for this transducer/mode.

Table 16: Transducer Model L25x/13-6

Operating Mode: PW Doppler

Index Label		M.I.	TIS			TIB	TIC	
			Scan	Non-scan		Non-scan		
				A _{aprt} ≤1	A _{aprt} >1			
Global Maximum Index Value		(a)	—	(a)	—	1.6	(b)	
Associated Acoustic Parameter	p _{r,3} (MPa)	#						
	W ₀ (mW)		—	#		14.02	#	
	min of [W ₃ (z ₁), I _{TA,3} (z ₁)] (mW)				—			
	z ₁ (cm)				—			
	z _{bp} (cm)				—			
	z _{sp} (cm)	#				0.6		
	d _{eq} (z _{sp}) (cm)					0.155		
	f _c (MHz)	#	—	#	—	6.00	#	
	Dim of A _{aprt}	X (cm)		—	#	—	0.16	#
Y (cm)			—	#	—	0.3	#	
Other Information	PD (μsec)	#						
	PRF (Hz)	#						
	p _r @PII _{max} (MPa)	#						
	d _{eq} @PII _{max} (cm)					0.1549		
	Focal Length	FL _x (cm)		—	#	—		#
		FL _y (cm)		—	#	—		#
I _{PA,3} @MI _{max} (W/cm ²)	#							
Operating Control Conditions	Control 1: Exam Type					Vas/Nrv/ Ven		
	Control 2: Sample Volume					12 mm		
	Control 3: PRF					20833		
	Control 4: Sample Volume Position					Zone 0		

(a) This index is not required for this operating mode; value is <1.

(b) This transducer is not intended for transcranial or neonatal cephalic uses.

#No data are reported for this operating condition since the global maximum index value is not reported for the reason listed. (Reference Global Maximum Index Value line.)

— Data are not applicable for this transducer/mode.

Table 17: Transducer Model: L38x/10-5

Operating Mode: CPD/Color

Index Label		M.I.	TIS			TIB	TIC	
			Scan	Non-scan		Non-scan		
				$A_{aprt} \leq 1$	$A_{aprt} > 1$			
Global Maximum Index Value		1.3	1.0	—	—	—	(b)	
Associated Acoustic Parameter	$p_{r,3}$ (MPa)	2.89						
	W_0 (mW)		64.88	—		—	#	
	min of [$W_{,3}(z_1), I_{TA,3}(z_1)$] (mW)				—			
	z_1 (cm)				—			
	z_{bp} (cm)				—			
	z_{sp} (cm)	1.1				—		
	$d_{eq}(z_{sp})$ (cm)					—		
	f_c (MHz)	4.91	4.91	—	—	—	#	
	Dim of A_{aprt}	X (cm)		0.54	—	—	—	#
Y (cm)			0.4	—	—	—	#	
Other Information	PD (μ sec)	0.529						
	PRF (Hz)	9547						
	$p_r@PII_{max}$ (MPa)	3.48						
	$d_{eq}@PII_{max}$ (cm)					—		
	Focal Length	FL _x (cm)		1.5	—	—		#
		FL _y (cm)		2.5	—	—		#
$I_{PA,3}@MI_{max}$ (W/cm ²)		439.3						
Operating Control Conditions	Control 1: Mode	Color	CPD					
	Control 2: Exam Type	Any	Bre					
	Control 3: PRF	331	2137					
	Control 4: Optimization/Depth	Any/3.1	Med/3.1					
	Control 5: Color Box Position/Size	Any	Def/Def/Def					

(a) This index is not required for this operating mode; value is <1.

(b) This transducer is not intended for transcranial or neonatal cephalic uses.

#No data are reported for this operating condition since the global maximum index value is not reported for the reason listed. (Reference Global Maximum Index Value line.)

— Data are not applicable for this transducer/mode.

Table 18: Transducer Model: L38x/10-5

Operating Mode: PW Doppler

Index Label		M.I.	TIS			TIB	TIC	
			Scan	Non-scan		Non-scan		
				$A_{aprt} \leq 1$	$A_{aprt} > 1$			
Global Maximum Index Value		1.04	—	2.0	—	2.6	(b)	
Associated Acoustic Parameter	$P_{r,3}$ (MPa)	2.345						
	W_0 (mW)		—	84.94		84.94	#	
	min of $[W_{.3}(z_1), I_{TA,3}(z_1)]$ (mW)				—			
	z_1 (cm)				—			
	z_{bp} (cm)				—			
	z_{sp} (cm)	0.8				1.3		
	$d_{eq}(z_{sp})$ (cm)					0.4685		
	f_c (MHz)	5.01	—	5.05	—	5.05	#	
	Dim of A_{aprt}	X (cm)		—	1.80	—	1.80	#
Y (cm)			—	0.4	—	0.4	#	
Other Information	PD (μ sec)	1.29						
	PRF (Hz)	1008						
	$P_r@PII_{max}$ (MPa)	2.693						
	$d_{eq}@PII_{max}$ (cm)					0.2533		
	Focal Length	FL_x (cm)		—	5.54	—		#
		FL_y (cm)		—	2.5	—		#
$I_{PA,3}@MI_{max}$ (W/cm^2)	284.5							
Operating Control Conditions	Control 1: Exam Type	Any		Vas		Vas		
	Control 2: Sample Volume	1 mm		12 mm		12 mm		
	Control 3: PRF	1008		Any		Any		
	Control 4: Sample Volume Position	Zone 0 (top)		Zone 7		Zone 7		

(a) This index is not required for this operating mode; value is <1.

(b) This transducer is not intended for transcranial or neonatal cephalic uses.

#No data are reported for this operating condition since the global maximum index value is not reported for the reason listed. (Reference Global Maximum Index Value line.)

— Data are not applicable for this transducer/mode.

Table 19: Transducer Model: P21x/5-1

Operating Mode: 2D

Index Label		M.I.	TIS		TIB	TIC	
			Scan	Non-scan			Non-scan
				$A_{aprt} \leq 1$	$A_{aprt} > 1$		
Global Maximum Index Value		1.3	1.1	—	—	(b)	
Associated Acoustic Parameter	$p_{r,3}$ (MPa)	1.83					
	W_0 (mW)		122.87	—	—	#	
	min of [$W_{,3}(z_1), I_{TA,3}(z_1)$] (mW)				—		
	z_1 (cm)				—		
	z_{bp} (cm)				—		
	z_{sp} (cm)	5.1				—	
	$d_{eq}(z_{sp})$ (cm)					—	
	f_c (MHz)	1.84	1.88	—	—	—	#
	Dim of A_{aprt}	X (cm)		0.590	—	—	—
Y (cm)			1.3	—	—	—	#
Other Information	PD (μ sec)	0.963					
	PRF (Hz)	4421					
	$p_r@PII_{max}$ (MPa)	2.574					
	$d_{eq}@PII_{max}$ (cm)					—	
	Focal Length	FL _x (cm)		1.55	—	—	#
		FL _y (cm)		5.5	—	—	#
$I_{PA,3}@MI_{max}$ (W/cm ²)		209.0					
Operating Control Conditions	Control 1: Exam Type		Card	Abd/OB			
	Control 2: Optimization		Pen/Gen	Any			
	Control 3: Depth		4.7/7.6 cm	4.7			
	Control 4: THI		On	On			

(a) This index is not required for this operating mode; value is <1.

(b) This transducer is not intended for transcranial or neonatal cephalic uses.

#No data are reported for this operating condition since the global maximum index value is not reported for the reason listed. (Reference Global Maximum Index Value line.)

— Data are not applicable for this transducer/mode.

Table 20: Transducer Model: P21x/5-1

Operating Mode: M Mode

Index Label		M.I.	TIS		TIB	TIC	
			Scan	Non-scan			Non-scan
				$A_{aprt} \leq 1$	$A_{aprt} > 1$		
Global Maximum Index Value		1.5	—	(a)	—	(a)	
Associated Acoustic Parameter	$p_{r,3}$ (MPa)	2.10					
	W_0 (mW)		—	#		#	
	min of [$W_{,3}(z_1), I_{TA,3}(z_1)$]	(mW)			—		
	z_1 (cm)				—		
	z_{bp} (cm)				—		
	z_{sp} (cm)	3.645				#	
	$d_{eq}(z_{sp})$ (cm)					#	
	f_c (MHz)	1.93	—	#	—	#	#
	Dim of A_{aprt}	X (cm)		—	#	—	#
Y (cm)			—	#	—	#	#
Other Information	PD (μ sec)	0.904					
	PRF (Hz)	800					
	$p_r@PII_{max}$ (MPa)	2.679					
	$d_{eq}@PII_{max}$ (cm)					#	
	Focal Length	FL _x (cm)		—	#	—	#
		FL _y (cm)		—	#	—	#
$I_{PA,3}@MI_{max}$ (W/cm ²)	237.4						
Operating Control Conditions	Control 1: Exam Type		Abd/ OB				
	Control 2: Optimization		Gen/ Res				
	Control 3: Depth		7.5 cm				
	Control 4: THI		On				
	Control 5: MB		On				

(a) This index is not required for this operating mode; value is <1.

(b) This transducer is not intended for transcranial or neonatal cephalic uses.

#No data are reported for this operating condition since the global maximum index value is not reported for the reason listed. (Reference Global Maximum Index Value line.)

— Data are not applicable for this transducer/mode.

Table 21: Transducer Model: P21x/5-1

Operating Mode: CPD/Color

Index Label		M.I.	TIS			TIB	TIC	
			Scan	Non-scan		Non-scan		
				$A_{aprt} \leq 1$	$A_{aprt} > 1$			
Global Maximum Index Value		1.5	1.3	—	—	—	(b)	
Associated Acoustic Parameter	$p_{r,3}$ (MPa)	2.19						
	W_0 (mW)		136.91	—		—	#	
	min of [$W_{,3}(z_1), I_{TA,3}(z_1)$] (mW)				—			
	z_1 (cm)				—			
	z_{bp} (cm)				—			
	z_{sp} (cm)	4.5				—		
	$d_{eq}(z_{sp})$ (cm)					—		
	f_c (MHz)	2.15	2.16	—	—	—	#	
	Dim of A_{aprt}	X (cm)		0.918	—	—	—	#
Y (cm)			1.3	—	—	—	#	
Other Information	PD (μ sec)	1.20						
	PRF (Hz)	1063						
	$p_r@PII_{max}$ (MPa)	2.574						
	$d_{eq}@PII_{max}$ (cm)					—		
	Focal Length	FL_x (cm)		3.68	—	—		#
		FL_y (cm)		5.5	—	—		#
	$I_{PA,3}@MI_{max}$ (W/cm^2)	330.4						
Operating Control Conditions	Control 1: Mode		Color	CPD				
	Control 2: Exam Type		Abd/ OB	OB				
	Control 3: PRF/Depth		300/10	850/7.5				
	Control 4: Color Optimization		Any	Med				
	Control 5: THI		On	Off				
	Control 6: Color Box Size		Any	Short and Narrow				

(a) This index is not required for this operating mode; value is <1.

(b) This transducer is not intended for transcranial or neonatal cephalic uses.

#No data are reported for this operating condition since the global maximum index value is not reported for the reason listed. (Reference Global Maximum Index Value line.)

— Data are not applicable for this transducer/mode.

Table 22: Transducer Model: P21x/5-1

Operating Mode: PW Doppler

Index Label		M.I.	TIS		TIB	TIC		
			Scan	Non-scan			Non-scan	
				A _{aprt} ≤1	A _{aprt} >1			
Global Maximum Index Value		1.2	—	—	1.3	3.9	(b)	
Associated Acoustic Parameter	p _{r,3} (MPa)	1.844						
	W ₀ (mW)		—	—		93.28	#	
	min of [W ₃ (z ₁), I _{TA,3} (z ₁)] (mW)				120.13			
	z ₁ (cm)				3.1			
	z _{bp} (cm)				2.66			
	z _{sp} (cm)	3.718				0.6		
	d _{eq} (z _{sp}) (cm)					0.49		
	f _c (MHz)	2.16	—	—	2.22	2.23	#	
	Dim of A _{aprt}	X (cm)		—	—	1.9	0.459	#
Y (cm)			—	—	1.3	1.3	#	
Other Information	PD (μsec)	1.21						
	PRF (Hz)	1562.5						
	p _r @PII _{max} (MPa)	2.432						
	d _{eq} @PII _{max} (cm)					0.49		
	Focal Length	FL _x (cm)		—	—	13.84		#
		FL _y (cm)		—	—	5.5		#
	I _{PA,3} @MI _{max} (W/cm ²)	187.5						
Operating Control Conditions	Control 1: Exam Type	Card			Card	Any		
	Control 2: Sample Volume	1mm			3mm	14mm		
	Control 3: PRF	1563			3906	10417		
	Control 4: Sample Volume Position	Zone 1			Zone 4	Zone 0		

(a) This index is not required for this operating mode; value is <1.

(b) This transducer is not intended for transcranial or neonatal cephalic uses.

#No data are reported for this operating condition since the global maximum index value is not reported for the reason listed. (Reference Global Maximum Index Value line.)

— Data are not applicable for this transducer/mode.

Table 23: Transducer Model: P21x/5-1

Operating Mode: CW Doppler

Index Label		M.I.	TIS			TIB	TIC	
			Scan	Non-scan		Non-scan		
				$A_{aprt} \leq 1$	$A_{aprt} > 1$			
Global Maximum Index Value		(a)	—	—	1.0	3.4	(b)	
Associated Acoustic Parameter	$p_{r,3}$ (MPa)	#						
	W_0 (mW)		—	—		88.30	#	
	min of [$W_{.3}(z_1), I_{TA,3}(z_1)$] (mW)				102.54			
	z_1 (cm)				1.386			
	z_{bp} (cm)				1.71			
	z_{sp} (cm)	#				1.255		
	$d_{eq}(z_{sp})$ (cm)					0.49		
	f_c (MHz)	#	—	—	2.00	2.00	#	
	Dim of A_{aprt}	X (cm)		—	—	0.7865	0.6554	#
Y (cm)			—	—	1.3	1.3	#	
Other Information	PD (μ sec)	#						
	PRF (Hz)	#						
	$p_r@PII_{max}$ (MPa)	#						
	$d_{eq}@PII_{max}$ (cm)					0.45		
	Focal Length	FL _x (cm)		—	—	13.84		#
		FL _y (cm)		—	—	5.5		#
$I_{PA,3}@MI_{max}$ (W/cm ²)	#							
Operating Control Conditions	Control 1: Exam Type				Card	Card		
	Control 2: Zone				Zone 4	Zone 1		

(a) This index is not required for this operating mode; value is <1.

(b) This transducer is not intended for transcranial or neonatal cephalic uses.

#No data are reported for this operating condition since the global maximum index value is not reported for the reason listed. (Reference Global Maximum Index Value line.)

— Data are not applicable for this transducer/mode.

Terms used in the acoustic output tables

Table 24: Acoustic Output Terms and Definitions

Term	Definition
$I_{SPTA,3}$	Derated spatial peak, temporal average intensity in units of milliwatts/cm ² .
TI type	Applicable thermal index for the transducer, imaging mode, and exam type.
TI value	Thermal index value for the transducer, imaging mode, and exam type.
MI	Mechanical index.
$I_{pa,3}@MI_{max}$	Derated pulse average intensity at the maximum MI in units of W/cm ² .
TIS	(Soft tissue thermal index) is a thermal index related to soft tissues. TIS scan is the soft tissue thermal index in an auto-scanning mode. TIS non-scan is the soft tissue thermal index in the non-autoscanning mode.
TIB	(Bone thermal index) is a thermal index for applications in which the ultrasound beam passes through soft tissue and a focal region is in the immediate vicinity of bone. TIB non-scan is the bone thermal index in the non-autoscanning mode.
TIC	(Cranial bone thermal index) is the thermal index for applications in which the ultrasound beam passes through bone near the beam entrance into the body.
A_{aprt}	Area of the active aperture measured in cm ² .
$P_{r,3}$	Derated peak rarefactional pressure associated with the transmit pattern giving rise to the value reported under MI (Megapascals).
Wo	Ultrasonic power, except for TIS _{scan} , in which case it is the ultrasonic power passing through a one centimeter window in units of milliwatts.
$W_{,3}(z_1)$	Derated ultrasonic power at axial distance z_1 in units of milliwatts.
$I_{SPTA,3}(z_1)$	Derated spatial-peak temporal-average intensity at axial distance z_1 (milliwatts per square centimeter).
z_1	Axial distance corresponding to the location of maximum [$\min(W_{,3}(z), I_{TA,3}(z) \times 1 \text{ cm}^2)$], where $z \geq z_{bp}$ in centimeters.
z_{bp}	$1.69 \sqrt{(A_{aprt})}$ in centimeters.
z_{sp}	For MI, the axial distance at which $p_{r,3}$ is measured. For TIB, the axial distance at which TIB is a global maximum (for example, $z_{sp} = z_{b,3}$) in centimeters.

Table 24: Acoustic Output Terms and Definitions (Continued)

Term	Definition
$d_{eq}(z)$	Equivalent beam diameter as a function of axial distance z , and is equal to $\sqrt{(4/(\pi))((W_0)/(I_{TA}(z)))}$, where $I_{TA}(z)$ is the temporal-average intensity as a function of z in centimeters.
f_c	Center frequency in MHz.
Dim. of A_{aprt}	Active aperture dimensions for the azimuthal (x) and elevational (y) planes in centimeters.
PD	Pulse duration (microseconds) associated with the transmit pattern giving rise to the reported value of MI.
PRF	Pulse repetition frequency associated with the transmit pattern giving rise to the reported value of MI in Hertz.
$p_r@PII_{max}$	Peak rarefactional pressure at the point where the free-field, spatial-peak pulse intensity integral is a maximum in Megapascals.
$d_{eq}@PII_{max}$	Equivalent beam diameter at the point where the free-field, spatial-peak pulse intensity integral is a maximum in centimeters.
FL	Focal length, or azimuthal (x) and elevational (y) lengths, if different measured in centimeters.

Acoustic measurement precision and uncertainty

All table entries have been obtained at the same operating conditions that give rise to the maximum index value in the first column of the table. Measurement precision and uncertainty for power, pressure, intensity, and other quantities that are used to derive the values in the acoustic output table are shown in the table below. In accordance with Section 6.4 of the Output Display Standard, the following measurement precision and uncertainty values are determined by making repeat measurements and stating the standard deviation as a percentage.

Table 25: Acoustic Measurement Precision and Uncertainty

Quantity	Precision (% of standard deviation)	Uncertainty (95% confidence)
Pr	1.9%	±11.2%
Pr ₃	1.9%	±12.2%
Wo	3.4%	±10%
f_c	0.1%	±4.7%

Table 25: Acoustic Measurement Precision and Uncertainty (Continued)

Quantity	Precision (% of standard deviation)	Uncertainty (95% confidence)
P11	3.2%	+12.5 to -16.8%
P11.3	3.2%	+13.47 to -17.5%

Labeling symbols

The following symbols are used on the products, packaging, and containers.

Table 26: Labeling Symbols









Symbol	Definition
	Alternating Current (AC)
	Class 1 device indicating manufacturer's declaration of conformance with Annex VII of 93/42/EEC
	Class 1 device requiring verification by the Notified Body of sterilization or measurement features, or to a Class IIa, IIb, or III device requiring verification or auditing by the Notified Body to applicable Annex(es) of 93/42/EEC
	Attention, see the user guide
	Device complies with relevant Australian regulations for electronic devices.
	Batch code, date code, or lot code type of control number
	Biological risk
	Device complies with relevant Brazilian regulations for electro-medical devices.
	Canadian Standards Association. The "C" and "US" indicators next to this mark signify that the product has been evaluated to the applicable CSA and ANSI/UL Standards, for use in Canada and the US, respectively.

Table 26: Labeling Symbols (Continued)













Symbol	Definition
	Catalog number
	Collect separately from other household waste (see European Commission Directive 93/86/EEC). Refer to local regulations for disposal.
	Contents sterilized using ethylene oxide process.
	Corrugated recycle
	Dangerous voltage
	Date of manufacture
	Direct Current (DC)
	Do not get wet.
	Do not stack over 2 high.
	Do not stack over 5 high.
	Do not stack over 10 high.
	Electrostatic sensitive devices
	Device complies with relevant FCC regulations for electronic devices.

Table 26: Labeling Symbols (Continued)

















Symbol	Definition
	Fragile
GEL 	Gel sterilized by radiation.
	Hot
	Indoor use only
	Device emits a static (DC) magnetic field.
	Non-ionizing radiation
	Paper recycle
	Serial number type of control number
	Storage temperature conditions
IPX7	Submersible. Protected against the effects of temporary immersion.
IPX8	Water-Tight Equipment. Protected against the effects of extended immersion.
	Handle transducer with care.
	Follow manufacturer's instructions for disinfecting time.
	Disinfect transducer.

Table 26: Labeling Symbols (Continued)

Symbol	Definition
	Type BF patient applied part (B = body, F = floating applied part)
	Underwriter's Laboratories labeling
	Pollution Control Logo. (Applies to all parts/products listed in the China RoHS disclosure table. May not appear on the exterior of some parts/products because of space limitations.)
	China Compulsory Certificate mark ("CCC Mark"). A compulsory safety mark for compliance to Chinese national standards for many products sold in the People's Republic of China.
	Contains mercury. (Applies to the LCD and may apply to other components in the ultrasound system.)
WARNING: Connect Only Accessories and Peripherals Recommended by SonoSite	WARNING: Connect Only Accessories and Peripherals Recommended by SonoSite

Chapter 7: References

Measurement accuracy

The measurements provided by the system do not define a specific physiological or anatomical parameter. Rather, the measurements are of a physical property such as distance for evaluation by the clinician. The accuracy values require that you can place the calipers over one pixel. The values do not include acoustic anomalies of the body.

The 2D linear distance measurement results are displayed in centimeters with one place past the decimal point, if the measurement is ten or greater; two places past the decimal point, if the measurement is less than ten.

The linear distance measurement components have the accuracy and range shown in the following tables.

Table 1: 2D Measurement Accuracy and Range

2D Measure Accuracy and Range	System Tolerance ^a	Accuracy By	Test Method ^b	Range (cm)
Axial Distance	< ±2% plus 1% of full scale	Acquisition	Phantom	0-26 cm
Lateral Distance	< ±2% plus 1% of full scale	Acquisition	Phantom	0-35 cm
Diagonal Distance	< ±2% plus 1% of full scale	Acquisition	Phantom	0-44 cm
Area ^c	< ±4% plus (2% of full scale/smallest dimension) * 100 plus 0.5%	Acquisition	Phantom	0.01-720 cm ²
Circumference ^d	< ±3% plus (1.4% of full scale/smallest dimension) * 100 plus 0.5%	Acquisition	Phantom	0.01-96 cm

a.Full scale for distance implies the maximum depth of the image.

b.An RMI 413a model phantom with 0.7 dB/cm MHz attenuation was used.

c.The area accuracy is defined using the following equation:

% tolerance = ((1 + lateral error) * (1 + axial error) - 1) * 100 + 0.5%.

d.The circumference accuracy is defined as the greater of the lateral or axial accuracy and by the following equation:

$$\% \text{ tolerance} = (\sqrt{2} (\text{maximum of 2 errors}) * 100) + 0.5\%.$$

Table 2: M Mode Measurement and Calculation Accuracy and Range

M Mode Measurement Accuracy and Range	System Tolerance	Accuracy By	Test Method	Range
Distance	< +/- 2% plus 1% of full scale ^a	Acquisition	Phantom ^b	0-26 cm
Time	< +/- 2% plus 1% of full scale ^c	Acquisition	Phantom ^d	0.01-10 sec
Heart Rate	< +/- 2% plus (Full Scale ^c * Heart Rate/100) %	Acquisition	Phantom ^d	5-923 bpm

a.Full scale for distance implies the maximum depth of the image.

b.An RMI 413a model phantom with 0.7 dB/cm MHz attenuation was used.

c.Full scale for time implies the total time displayed on the scrolling graphic image.

d.SonoSite special test equipment was used.

Table 3: PW Doppler Mode Measurement and Calculation Accuracy and Range

Doppler Mode Measurement Accuracy and Range	System Tolerance	Accuracy By	Test Method^a	Range
Velocity cursor	< +/- 2% plus 1% of full scale ^b	Acquisition	Phantom	0.01 cm/sec-550 cm/sec
Frequency cursor	< +/- 2% plus 1% of full scale ^b	Acquisition	Phantom	0.01kHz-20.8 kHz
Time	< +/- 2% plus 1% of full scale ^c	Acquisition	Phantom	0.01-10 sec

a.SonoSite special test equipment was used.

b.Full scale for frequency or velocity implies the total frequency or velocity magnitude, displayed on the scrolling graphic image.

c.Full scale for time implies the total time displayed on the scrolling graphic image.

Sources of measurement errors

In general, two types of errors can be introduced into the measurement:

Acquisition Error Includes errors introduced by the ultrasound system electronics relating to signal acquisition, signal conversion, and signal processing for display. Additionally, computational and display errors are introduced by the generation of the pixel scale factor, application of that factor to the caliper positions on the screen, and the measurement display.

Algorithmic Error The error introduced by measurements, which are input to higher order calculations. This error is associated with floating-point versus integer-type math, which is subject to errors introduced by rounding versus truncating results for display of a given level of significant digit in the calculation.

Measurement publications and terminology

The following sections list the publications and terminology used for each calculation result.

Terminology and measurements comply with AIUM published standards.

Cardiac references

Acceleration (ACC) in cm/s²

Zwiebel, W.J. *Introduction to Vascular Ultrasonography*. 4th ed., W.B. Saunders Company, (2000), 52.

ACC = abs (delta velocity/delta time)

Acceleration Time (AT) in msec

Oh, J.K., J.B. Seward, A.J. Tajik. *The Echo Manual*. 2nd ed., Lippincott, Williams, and Wilkins, (1999), 219.

Aortic Valve Area (AVA) by Continuity Equation in cm²

Reynolds, Terry. *The Echocardiographer's Pocket Reference*. 2nd ed., School of Cardiac Ultrasound, Arizona Heart Institute, (2000), 393, 442.

$$A_2 = A_1 * V_1/V_2$$

where:

A_2 = Ao valve area

A_1 = LVOT area; V_1 = LVOT velocity; V_2 = Ao valve velocity

LVOT = Left Ventricular Outflow Tract

$$\text{AVA} (PV_{\text{LVOT}}/PV_{\text{AO}}) * CSA_{\text{LVOT}}$$

$$\text{AVA} (VTI_{\text{LVOT}}/VTI_{\text{AO}}) * CSA_{\text{LVOT}}$$

Body Surface Area (BSA) in m²

Grossman, W. *Cardiac Catheterization and Angiography*. Philadelphia: Lea and Febiger, (1980), 90.

$$\text{BSA} = 0.007184 * \text{Weight}^{0.425} * \text{Height}^{0.725}$$

Weight = kilograms

Height = centimeters

Cardiac Index (CI) in l/min/m²

Oh, J.K., J.B. Seward, A.J. Tajik. *The Echo Manual*. 2nd Edition, Boston: Little, Brown and Company, (1999), 59.

$$\text{CI} = \text{CO}/\text{BSA}$$

where: CO = Cardiac Output
 BSA = Body Surface Area

Cardiac Output (CO) in l/min

Oh, J.K., J.B. Seward, A.J. Tajik *The Echo Manual*. 2nd ed., Lippincott, Williams, and Wilkins, (1999), 59.

$$\text{CO} = (\text{SV} * \text{HR})/1000$$

where: CO = Cardiac Output
 SV = Stroke Volume
 HR = Heart Rate

Cross Sectional Area (CSA) in cm²

Reynolds, Terry. *The Echocardiographer's Pocket Reference*. 2nd ed., School of Cardiac Ultrasound, Arizona Heart Institute, (2000), 383.

$$\text{CSA} = 0.785 * \text{D}^2$$

where: D = diameter of the anatomy of interest

Deceleration Time in msec

Reynolds, Terry. *The Echocardiographer's Pocket Reference*. 2nd ed., School of Cardiac Ultrasound, Arizona Heart Institute, (2000), 453.

$$|\text{time a} - \text{time b}|$$

Delta Pressure: Delta Time (dP:dT) in mmHg/s

Otto, C.M. *Textbook of Clinical Echocardiography*. 2nd ed., W.B. Saunders Company, (2000), 117, 118.

32 mmHg/time interval in seconds

E:A Ratio in cm/sec

E:A = velocity E/velocity A

E/Ea Ratio

Reynolds, Terry. *The Echocardiographer's Pocket Reference*. 2nd ed., School of Cardiac Ultrasound, Arizona Heart Institute, (2000), 225.

E Velocity/Ea velocity

where: E velocity = Mitral Valve E velocity
Ea = annular E velocity, also known as: E prime

Effective Regurgitant Orifice (ERO) in mm²

Reynolds, Terry. *The Echocardiographer's Pocket Reference*. 2nd ed., School of Cardiac Ultrasound, Arizona Heart Institute, (2000), 455.

$ERO = 6.28 (r^2) * Va/MR \text{ Vel}$

where: r = radius
Va = aliasing velocity

Ejection Fraction (EF), percent

Oh, J.K., J.B. Seward, A.J. Tajik. *The Echo Manual*. 2nd ed., Lippincott, Williams, and Wilkins, (1999), 40.

$EF = ((LVEDV - LVESV)/LVEDV) * 100\%$

where: EF = Ejection Fraction
LVEDV = Left Ventricular End Diastolic Volume
LVESV = Left Ventricular End Systolic Volume

Elapsed Time (ET) in msec

ET = time between velocity cursors in milliseconds

Heart Rate (HR) in bpm

HR = 3 digit value input by user or measured on M Mode and Doppler image in one heart cycle

Interventricular Septum (IVS) Fractional Thickening, percent

Laurenceau, J. L., M.C. Malergue. *The Essentials of Echocardiography*. Le Hague: Martinus Nijhoff, (1981), 71.

$IVSFT = ((IVSS - IVSD)/IVSD) * 100\%$

where: IVSS = Interventricular Septal Thickness at Systole
IVSD = Interventricular Septal Thickness at Diastole

Isovolumic Relaxation Time (IVRT) in msec

Reynolds, Terry. *The Echocardiographer's Pocket Reference*. School of Cardiac Ultrasound, Arizona Heart Institute, (1993), 146.

$$| \text{time a} - \text{time b} |$$

Left Atrium/Aorta (LA/Ao)

Feigenbaum, H. *Echocardiography*. Philadelphia: Lea and Febiger, (1994), 206, Figure 4-49.

Left Ventricular End Volumes (Teichholz) in ml

Teichholz, L.E., T. Kreulen, M.V. Herman, et. al. "Problems in echocardiographic volume determinations: echocardiographic-angiographic correlations in the presence or absence of asynergy." *American Journal of Cardiology*, (1976), 37:7.

$$\text{LVESV} = (7.0 * \text{LVDS}^3) / (2.4 + \text{LVDS})$$

where: LVESV = Left Ventricular End Systolic Volume

LVDS = Left Ventricular Dimension at Systole

$$\text{LVEDV} = (7.0 * \text{LVDD}^3) / (2.4 + \text{LVDD})$$

where: LVEDV = Left Ventricular End Diastolic Volume

LVDD = Left Ventricular Dimension at Diastole

Left Ventricular Mass in gm

Oh, J.K., J.B. Seward, A.J. Tajik. *The Echo Manual*. 2nd Edition, Boston: Little, Brown and Company, (1999), 39.

$$\text{LV Mass} = 1.04 [(\text{LVID} + \text{PWT} + \text{IVST})^3 - \text{LVID}^3] * 0.8 + 0.6$$

where: LVID = Internal Dimension

PWT = Posterior Wall Thickness

IVST = Interventricular Septal Thickness

1.04 = Specific gravity of the myocardium

0.8 = Correction factor

Left Ventricular Volume: Biplane Method in ml

Schiller, N.B., P.M. Shah, M. Crawford, et.al. "Recommendations for Quantitation of the Left Ventricle by Two-Dimensional Echocardiography." *Journal of American Society of Echocardiography*. September-October 1989, 2:362.

$$V = \left(\frac{\pi}{4}\right) \sum_{i=1}^n a_i b_i \left(\frac{L}{n}\right)$$

where: V = Volume in ml

a = Diameter

b = Diameter

n = Number of segments (n=20)
 L = Length
 i = Segment

Left Ventricular Volume: Single Plane Method in ml

Schiller, N.B., P.M. Shah, M. Crawford, et.al. "Recommendations for Quantitation of the Left Ventricle by Two-Dimensional Echocardiography." *Journal of American Society of Echocardiography*. September-October 1989, 2:362.

$$V = \left(\frac{\pi}{4}\right) \sum_{i=1}^n a_i^2 \left(\frac{L}{n}\right)$$

where: V = Volume
 a = Diameter
 n = Number of segments (n=20)
 L = Length
 i = Segment

Left Ventricular Dimension (LVD) Fractional Shortening, percent

Oh, J.K., J.B. Seward, A.J. Tajik. *The Echo Manual*. Boston: Little, Brown and Company, (1994), 43-44.

$$\text{LVDFS} = ((\text{LVDD} - \text{LVDS})/\text{LVDD}) * 100\%$$

where: LVDD = Left Ventricle Dimension at Diastole
 LVDS = Left Ventricle Dimension at Systole

Left Ventricular Posterior Wall Fractional Thickening (LVPWFT), percent

Laurenceau, J. L., M.C. Malergue. *The Essentials of Echocardiography*. Le Hague: Martinus Nijhoff, (1981), 71.

$$\text{LVPWFT} = ((\text{LVPWS} - \text{LVPWD})/\text{LVPWD}) * 100\%$$

where: LVPWS = Left Ventricular Posterior Wall Thickness at Systole
 LVPWD = Left Ventricular Posterior Wall Thickness at Diastole

Mean Velocity (Vmean) in cm/s

Vmean = mean velocity

Mitral Valve Area (MVA) in cm²

Reynolds, Terry. *The Echocardiographer's Pocket Reference*. 2nd ed., School of Cardiac Ultrasound, Arizona Heart Institute, (2000), 391, 452.

$$\text{MVA} = 220/\text{PHT}$$

where: PHT = pressure half time

Note: 220 is an empirical derived constant and may not accurately predict mitral valve area in mitral prosthetic heart valves. The mitral valve area continuity equation may be utilized in mitral prosthetic heart valves to predict effective orifice area.

MV Flow Rate in cc/sec

Reynolds, Terry. *The Echocardiographer's Pocket Reference*. 2nd ed., School of Cardiac Ultrasound, Arizona Heart Institute, (2000), 396.

$$\text{Flow} = 6.28 (r^2) * Va$$

where: r = radius
 Va = aliasing Velocity

Pressure Gradient (PGr) in mmHG

Oh, J.K., J.B. Seward, A.J. Tajik. *The Echo Manual*. 2nd ed., Lippincott, Williams, and Wilkins, (1999), 64.

$$\text{PGr} = 4 * (\text{Velocity})^2$$

Peak E Pressure Gradient (E PG)

$$\text{E PG} = 4 * \text{PE}^2$$

Peak A Pressure Gradient (A PG)

$$\text{A PG} = 4 * \text{PA}^2$$

Peak Pressure Gradient (PGmax)

$$\text{PGmax} = 4 * \text{PV}^2$$

Mean Pressure Gradient (PGmean)

PGmean = Average of pressure gradients/Duration of flow

Pressure Half Time (PHT) in msec

Reynolds, Terry. *The Echocardiographer's Pocket Reference*. 2nd ed., School of Cardiac Ultrasound, Arizona Heart Institute, (2000), 391.

$$\text{PHT} = \text{DT} * 0.29$$

where: DT = deceleration time

Proximal Isovelocity Surface Area (PISA) in cm²

Oh, J.K., J.B. Seward, A.J. Tajik. *The Echo Manual*. 2nd ed., Boston: Little, Brown and Company, (1999), 125.

$$\text{PISA} = 2\pi r^2$$

where: $2\pi = 6.28$
 r = aliasing radius

Qp/Qs

Reynolds, Terry. *The Echocardiographer's Pocket Reference*. 2nd ed., School of Cardiac Ultrasound, Arizona Heart Institute, (2000), 400.

$Qp/Qs = SV_{Qp \text{ site}}/SV_{Qs \text{ site}}$

SV sites will vary depending upon the location of the shunt.

Regurgitant Fraction (RF) in percent

Oh, J.K., J.B. Seward, A.J. Tajik. *The Echo Manual*. Boston: Little, Brown and Company, (1999), 125.

$RF = RV / MV_{SV}$

where: RV = Regurgitant Volume
 MV SV = Mitral Stroke Volume

Regurgitant Volume (RV) in cc

Reynolds, Terry. *The Echocardiographer's Pocket Reference*. School of Cardiac Ultrasound, Arizona Heart Institute, (2000), 396, 455.

$RV = ERO * MR_{VTI}$

Right Ventricular Systolic Pressure (RVSP) in mmHg

Reynolds, Terry. *The Echocardiographer's Pocket Reference*. School of Cardiac Ultrasound, Arizona Heart Institute, (1993), 152.

$RVSP = 4 * (V_{max \ TR})^2 + RAP$

where: RAP = Right Atrial Pressure

Stroke Index (SI) in cc/m²

Mosby's Medical, Nursing, & Allied Health Dictionary, 4th ed., (1994), 1492.

$SI = SV/BSA$

where: SV = Stroke Volume
 BSA = Body Surface Area

Stroke Volume (SV) Doppler in ml

Oh, J.K., J.B. Seward, A.J. Tajik. *The Echo Manual*. 2nd ed., Lippincott, Williams, and Wilkins, (1999), 40, 59, 62.

$SV = (CSA * VTI)$

where CSA = Cross Sectional Area of the orifice (LVOT area)
 VTI = Velocity Time Integral of the aortic valve

Stroke Volume (SV) 2D and M Mode in ml

Oh, J.K., J.B. Seward, A.J. Tajik. *The Echo Manual*. 2nd ed., Boston: Little, Brown and Company, (1994), 44.

$$SV = (LVEDV - LVESV)$$

where: SV = Stroke Volume
LVEDV = End Diastolic Volume
LVESV = End Systolic Volume

Velocity Time Integral (VTI) in cm

Reynolds, Terry. *The Echocardiographer's Pocket Reference*. 2nd ed., School of Cardiac Ultrasound, Arizona Heart Institute, (2000), 383.

VTI = sum of abs (velocities [n])

where: Auto Trace – distance (cm) blood travels with each ejection period. Velocities are absolute values.

Obstetrical references

Amniotic Fluid Index (AFI)

Jeng, C. J., et al. "Amniotic Fluid Index Measurement with the Four Quadrant Technique During Pregnancy." *The Journal of Reproductive Medicine*, 35:7 (July 1990), 674-677.

Average Ultrasound Age (AUA)

The system provides an AUA derived from the component measurements from the measurement tables.

Estimated Date of Delivery (EDD) by Average Ultrasound Age (AUA)

Results are displayed as month/day/year.

$$EDD = \text{system date} + (280 \text{ days} - \text{AUA in days})$$

Estimated Date of Delivery (EDD) by Last Menstrual Period (LMP)

The date entered into the patient information for LMP must precede the current date.

Results are displayed as month/day/year.

$$EDD = \text{LMP date} + 280 \text{ days}$$

Estimated Fetal Weight (EFW)

Hadlock, F., et al. "Estimation of Fetal Weight with the Use of Head, Body, and Femur Measurements, A Prospective Study." *American Journal of Obstetrics and Gynecology*, 151:3 (February 1, 1985), 333-337.

Hansmann, M., et al. *Ultrasound Diagnosis in Obstetrics and Gynecology*. New York: Springer-Verlag, (1986), 154.

Osaka University. *Ultrasound in Obstetrics and Gynecology*. (July 20, 1990), 103-105.

Shepard M.J., V. A. Richards, R. L. Berkowitz, et al. "An Evaluation of Two Equations for Predicting Fetal Weight by Ultrasound." *American Journal of Obstetrics and Gynecology*, 142:1 (January 1, 1982), 47-54.

University of Tokyo, Shinozuka, N. FJSUM, et al. "Standard Values of Ultrasonographic Fetal Biometry." *Japanese Journal of Medical Ultrasonics*, 23:12 (1996), 880, Equation 1.

Gestational Age (GA) by Last Menstrual Period (LMP)

The gestational age derived from the LMP date entered on the patient information form.

Results are displayed in weeks and days, and is calculated as follows:

$GA(LMP) = \text{System date} - \text{LMP date}$

Gestational Age (GA) by Last Menstrual Period (LMPd) Derived from Established Due Date (Estab. DD)

Same as GA by Estab. DD.

The gestational age derived from the system derived LMP using the Established Due Date entered on the patient information form.

Results are displayed in weeks and days, and is calculated as follows:

$GA(LMPd) = \text{System Date} - \text{LMPd}$

Last Menstrual Period Derived (LMPd) by Established Due Date (Estab. DD)

Results are displayed as month/day/year.

$LMPd(\text{Estab. DD}) = \text{Estab. DD} - 280 \text{ days}$

Gestational age tables

Abdominal Circumference (AC)

Hadlock, F., et al. "Estimating Fetal Age: Computer-Assisted Analysis of Multiple Fetal Growth Parameters." *Radiology*, 152: (1984), 497-501.

Hansmann, M., et al. *Ultrasound Diagnosis in Obstetrics and Gynecology*. New York: Springer-Verlag, (1986), 431.

University of Tokyo, Shinozuka, N. FJSUM, et al. "Standard Values of Ultrasonographic Fetal Biometry." *Japanese Journal of Medical Ultrasonics*, 23:12 (1996), 885.

WARNING: The gestational age calculated by your SonoSite system does not match the age in the aforementioned reference at the 20.0 cm and 30.0 cm abdominal circumference (AC) measurements. The implemented algorithm extrapolates the gestational age from the slope of the curve of all table measurements, rather than decreasing the gestational age for a larger AC measurement indicated in the referenced table. This results in the gestational age always increasing with an increase in AC.

Anteroposterior Trunk Diameter (APTD)

University of Tokyo, Shinozuka, N. FJSUM, et al. "Standard Values of Ultrasonographic Fetal Biometry." *Japanese Journal of Medical Ultrasonics*, 23:12 (1996), 885.

Biparietal Diameter (BPD)

Chitty, L. S. and D.G. Altman. "New charts for ultrasound dating of pregnancy." *Ultrasound in Obstetrics and Gynecology* 10: (1997), 174-179, Table 3.

Hadlock, F., et al. "Estimating Fetal Age: Computer-Assisted Analysis of Multiple Fetal Growth Parameters." *Radiology*, 152: (1984), 497-501.

Hansmann, M., et al. *Ultrasound Diagnosis in Obstetrics and Gynecology*. New York: Springer-Verlag, (1986), 440.

Osaka University. *Ultrasound in Obstetrics and Gynecology*. (July 20, 1990), 98.

University of Tokyo, Shinozuka, N. FJSUM, et al. "Standard Values of Ultrasonographic Fetal Biometry." *Japanese Journal of Medical Ultrasonics*, 23:12 (1996), 885.

Crown Rump Length (CRL)

Hadlock, F., et al. "Fetal Crown-Rump Length: Re-evaluation of Relation to Menstrual Age (5-18 weeks) with High-Resolution, Real-Time Ultrasound." *Radiology*, 182: (February 1992), 501-505.

Hansmann, M., et al. *Ultrasound Diagnosis in Obstetrics and Gynecology*. New York: Springer-Verlag, (1986), 439.

Osaka University. *Ultrasound in Obstetrics and Gynecology*. (July 20, 1990), 20 and 96.

Tokyo University. "Gestational Weeks and Computation Methods." *Ultrasound Imaging Diagnostics*, 12:1 (1982-1), 24-25, Table 3.

Femur Length (FL)

Chitty, L. S. and D.G. Altman. "New charts for ultrasound dating of pregnancy." *Ultrasound in Obstetrics and Gynecology* 10: (1997), 174-179, Table 8, 186.

Hadlock, F., et al. "Estimating Fetal Age: Computer-Assisted Analysis of Multiple Fetal Growth Parameters." *Radiology*, 152: (1984), 497-501.

Hansmann, M., et al. *Ultrasound Diagnosis in Obstetrics and Gynecology*. New York: Springer-Verlag, (1986), 431.

Osaka University. *Ultrasound in Obstetrics and Gynecology*. (July 20, 1990), 101-102.

University of Tokyo, Shinozuka, N. FJSUM, et al. "Standard Values of Ultrasonographic Fetal Biometry." *Japanese Journal of Medical Ultrasonics*, 23:12 (1996), 886.

Fetal Trunk Cross-Sectional Area (FTA)

Osaka University. *Ultrasound in Obstetrics and Gynecology*. (July 20, 1990), 99-100.

Gestational Sac (GS)

Hansmann, M., et al. *Ultrasound Diagnosis in Obstetrics and Gynecology*. New York: Springer-Verlag, (1986).

Nyberg, D.A., et al. "Transvaginal Ultrasound." *Mosby Yearbook*, (1992), 76.

Gestational sac measurements provide a fetal age based on the mean of one, two, or three distance measurements; however, Nyberg's gestational age equation requires all three distance measurements for an accurate estimate.

Tokyo University. "Gestational Weeks and Computation Methods." *Ultrasound Imaging Diagnostics*, 12:1 (1982-1).

Head Circumference (HC)

Chitty, L. S. and D.G. Altman. "New charts for ultrasound dating of pregnancy." *Ultrasound in Obstetrics and Gynecology* 10: (1997), 174-191, Table 5, 182.

Hadlock, F., et al. "Estimating Fetal Age: Computer-Assisted Analysis of Multiple Fetal Growth Parameters." *Radiology*, 152: (1984), 497-501.

Hansmann, M., et al. *Ultrasound Diagnosis in Obstetrics and Gynecology*. New York: Springer-Verlag, (1986), 431.

Occipito-Frontal Diameter (OFD)

Hansmann, M., et al. *Ultrasound Diagnosis in Obstetrics and Gynecology*. New York: Springer-Verlag, (1986), 431.

Transverse Trunk Diameter (TTD)

Hansmann, M., et al. *Ultrasound Diagnosis in Obstetrics and Gynecology*. New York: Springer-Verlag, (1986), 431.

University of Tokyo, Shinozuka, N. FJSUM, et al. "Standard Values of Ultrasonographic Fetal Biometry." *Japanese Journal of Medical Ultrasonics*, 23:12 (1996), 885.

Growth analysis tables

Abdominal Circumference (AC)

Chitty, Lyn S. et al. "Charts of Fetal Size: 3. Abdominal Measurements." *British Journal of Obstetrics and Gynaecology* 101: (February 1994), 131, Appendix: AC-Derived.

Hadlock, F., et al. "Estimating Fetal Age: Computer-Assisted Analysis of Multiple Fetal Growth Parameters." *Radiology*, 152: (1984), 497-501.

Jeanty P., E. Cousaert, and F. Cantraine. "Normal Growth of the Abdominal Perimeter." *American Journal of Perinatology*, 1: (January 1984), 129-135.

(Also published in Hansmann, Hackeloer, Staudach, Wittman. *Ultrasound Diagnosis in Obstetrics and Gynecology*. Springer-Verlag, New York, (1986), 179, Table 7.13.)

Biparietal Diameter (BPD)

Chitty, Lyn S. et al. "Charts of Fetal Size: 2. Head Measurements." *British Journal of Obstetrics and Gynaecology* 101: (January 1994), 43, Appendix: BPD-Outer-Inner.

Hadlock, F., et al. "Estimating Fetal Age: Computer-Assisted Analysis of Multiple Fetal Growth Parameters." *Radiology*, 152: (1984), 497-501.

Jeanty P, E. Cousaert, and F. Cantraine. "A Longitudinal Study of Fetal Limb Growth." *American Journal of Perinatology*, 1: (January 1984), 136-144, Table 5.

(Also published in Hansmann, Hackeloer, Staudach, Wittman. *Ultrasound Diagnosis in Obstetrics and Gynecology*. Springer-Verlag, New York, (1986), 176, Table 7.8.)

Estimated Fetal Weight (EFW)

Hadlock F., et al. "In Utero Analysis of Fetal Growth: A Sonographic Weight Standard." *Radiology*, 181: (1991), 129-133.

Jeanty, Philippe, F. Cantraine, R. Romero, E. Cousaert, and J. Hobbins. "A Longitudinal Study of Fetal Weight Growth." *Journal of Ultrasound in Medicine*, 3: (July 1984), 321-328, Table 1.

(Also published in Hansmann, Hackeloer, Staudach, and Wittman. *Ultrasound Diagnosis in Obstetrics and Gynecology*. Springer-Verlag, New York, (1986), 186, Table 7.20.)

Femur Length (FL)

Chitty, Lyn S. et al. "Charts of Fetal Size: 4. Femur Length." *British Journal of Obstetrics and Gynaecology* 101: (February 1994), 135.

Hadlock, F., et al. "Estimating Fetal Age: Computer-Assisted Analysis of Multiple Fetal Growth Parameters." *Radiology*, 152: (1984), 497-501.

Jeanty P, E. Cousaert, and F. Cantraine. "A Longitudinal Study of Fetal Limb Growth." *American Journal of Perinatology*, 1: (January 1984), 136-144, Table 5.

(Also published in Hansmann, Hackeloer, Staudach, Wittman. *Ultrasound Diagnosis in Obstetrics and Gynecology*. Springer-Verlag, New York, (1986), 182, Table 7.17.)

Head Circumference (HC)

Chitty, Lyn S., et al. "Charts of Fetal Size: 2. Head Measurements." *British Journal of Obstetrics and Gynaecology* 101: (January 1994), 43, Appendix: HC-Derived.

Hadlock, F., et al. "Estimating Fetal Age: Computer-Assisted Analysis of Multiple Fetal Growth Parameters." *Radiology*, 152: (1984), 497-501.

Jeanty P, E. Cousaert, and F. Cantraine. "A longitudinal study of Fetal Head Biometry." *American J of Perinatology*, 1: (January 1984), 118-128, Table 3.

(Also published in Hansmann, Hackeloer, Staudach, Wittman. *Ultrasound Diagnosis in Obstetrics and Gynecology*. Springer-Verlag, New York, (1986), 176, Table 7.8.)

Head Circumference (HC)/Abdominal Circumference (AC)

Campbell S., Thoms Alison. "Ultrasound Measurements of the Fetal Head to Abdomen Circumference Ratio in the Assessment of Growth Retardation," *British Journal of Obstetrics and Gynaecology*, 84: (March 1977), 165-174.

Ratio calculations

FL/AC Ratio

Hadlock F.P., R. L. Deter, R. B. Harrist, E. Roecker, and S.K. Park. "A Date Independent Predictor of Intrauterine Growth Retardation: Femur Length/Abdominal Circumference Ratio," *American Journal of Roentgenology*, 141: (November 1983), 979-984.

FL/BPD Ratio

Hohler, C.W., and T.A. Quetel. "Comparison of Ultrasound Femur Length and Biparietal Diameter in Late Pregnancy," *American Journal of Obstetrics and Gynecology*, 141:7 (Dec. 1 1981), 759-762.

FL/HC Ratio

Hadlock F.P., R. B. Harrist, Y. Shah, and S. K. Park. "The Femur Length/Head Circumference Relation in Obstetric Sonography." *Journal of Ultrasound in Medicine*, 3: (October 1984), 439-442.

HC/AC Ratio

Campbell S., Thoms Alison. "Ultrasound Measurements of the Fetal Head to Abdomen Circumference Ratio in the Assessment of Growth Retardation," *British Journal of Obstetrics and Gynaecology*, 84: (March 1977), 165-174.

General references

+/x or S/D Ratio

$+/x = \text{abs}(\text{Velocity A}/\text{Velocity B})$

where A = velocity cursor +
 B = velocity cursor x

Acceleration Index (ACC)

Zwiebel, W.J. *Introduction to Vascular Ultrasonography*, 4th ed., W.B. Saunders Company, (2000), 52.

$\text{ACC} = \text{abs}(\text{delta velocity}/\text{delta time})$

Elapsed Time (ET)

ET = time between velocity cursors in milliseconds

Hip Angle/d:D Ratio

Graf, R. "Fundamentals of Sonographic Diagnosis of Infant Hip Dysplasia." *Journal of Pediatric Orthopedics*, Vol. 4, No. 6: 735-740, 1984.

Morin, C., Harcke, H., MacEwen, G. "The Infant Hip: Real-Time US Assessment of Acetabular Development." *Radiology* 177: 673-677, December 1985.

Intima Media Thickness (IMT)

Howard G, Sharrett AR, Heiss G, Evans GW, Chambless LE, Riley WA, et al. "Carotid Artery Intima-Medial Thickness Distribution in General Populations As Evaluated by B-Mode Ultrasound." ARIC Investigators. Atherosclerosis Risk in Communities. *Stroke*. (1993), 24:1297-1304.

O'Leary, Daniel H., MD and Polak, Joseph, F., MD, et al. "Use of Sonography to Evaluate Carotid Atherosclerosis in the Elderly. The Cardiovascular Health Study." *Stroke*. (September 1991), 22,1155-1163.

Redberg, Rita F., MD and Vogel, Robert A., MD, et al. "Task force #3—What is the Spectrum of Current and Emerging Techniques for the Noninvasive Measurement of Atherosclerosis?" *Journal of the American College of Cardiology*. (June 4, 2003), 41:11, 1886-1898.

Percent Area Reduction

Taylor K.J.W., P.N. Burns, P. Breslau. *Clinical Applications of Doppler Ultrasound*, Raven Press, N.Y., (1988), 130-136.

Zwiebel W.J., J.A. Zagzebski, A.B. Crummy, et al. "Correlation of peak Doppler frequency with lumen narrowing in carotid stenosis." *Stroke*, 3: (1982), 386-391.

$$\% \text{ Area Reduction} = (1 - A2(\text{cm}^2)/A1(\text{cm}^2)) * 100$$

where: A1 = original area of the vessel in square cm
 A2 = reduced area of the vessel in square cm

Percent Diameter Reduction

Handa, Nobuo et al., "Echo-Doppler Velocimeter in the Diagnosis of Hypertensive Patients: The Renal Artery Doppler Technique," *Ultrasound in Medicine and Biology*, 12:12 (1986), 945-952.

$$\% \text{ Diameter Reduction} = (1 - D2(\text{cm})/D1(\text{cm})) * 100$$

where: D1 = original diameter of the vessel in cm
 D2 = reduced diameter of the vessel in cm

Pressure Gradient (PGr) in mmHG

Oh, J.K., J.B. Seward, A.J. Tajik. *The Echo Manual*. 2nd ed., Lippincott, Williams, and Wilkins, (1999), 64.

$$4 * (\text{Velocity})^2$$

Peak E Pressure Gradient (E PG)

$$E\text{ PG} = 4 * PE^2$$

Peak A Pressure Gradient (A PG)

$$A\text{ PG} = 4 * PA^2$$

Peak Pressure Gradient (PGmax)

$$PG_{\text{max}} = 4 * PV^2$$

Mean Pressure Gradient (PGmean)

$$PG_{\text{mean}} = 4 * V_{\text{max}}^2$$

Pulsatility Index (PI)

Kurtz, A.B., W.D. Middleton. *Ultrasound-the Requisites*. Mosby Year Book, Inc., (1996), 469.

$$PI = (PSV - EDV)/V$$

where

PSV = peak systolic velocity

EDV = end diastolic velocity

V = mean flow velocity throughout the entire cardiac cycle

Resistive Index (RI)

Kurtz, A.B., W.D. Middleton. *Ultrasound-the Requisites*. Mosby Year Book, Inc., (1996), 467.

$$RI = \text{abs} ((\text{Velocity A} - \text{Velocity B})/\text{Velocity A}) \text{ in measurements}$$

where

A = velocity cursor +

B = velocity cursor x

Time Averaged Mean (TAM) in cm/s

$$TAM = \text{mean (mean Trace)}$$

Volume (Vol)

Beyer, W.H. *Standard Mathematical Tables*, 28th ed., CRC Press, Boca Raton, FL, (1987), 131.

Volume Flow (VF) in l/m

Allan, Paul L. et al. *Clinical Doppler Ultrasound*, 4th ed., Harcourt Publishers Limited. (2000), 36-38.

$$VF = CSA * TAM * .06$$

Chapter 8: Specifications

This chapter contains system and accessory specifications and standards. The specifications for recommended peripherals are in the manufacturers' instructions.

Dimensions

System	Display
Length: 11.8 in. (29.97 cm)	Length: 8.4 in. (21.34 cm)
Width: 10.8 in. (27.43 cm)	Height: 6.3 in. (16 cm)
Height: 3.1 in. (7.87 cm)	Diagonal: 10.4 in. (26.4 cm)
Weight: 8.5 lbs. (3.9 kg) with the C60x transducer and battery installed	

Supported transducers

- C11x/8-5 MHz (6 ft/1.8 m)
- C60x/5-2 MHz (5.5 ft/1.7 m)
- HFL38x/13-6 MHz (5.6 ft/1.7 m)
- ICTx/8-5 MHz (5.5 ft/1.7 m)
- L25x/13-6 MHz (7.5 ft/2.3 m)
- L38x/10-5 MHz (5.5 ft/1.7 m)
- P21x/5-1 MHz (6 ft/1.8 m)

Imaging modes

- 2D (256 gray shades)
- Color power Doppler (CPD) (256 colors)
- Color Doppler (Color) (256 colors)
- M Mode
- Pulsed wave (PW) Doppler
- Continuous wave (CW) Doppler
- Tissue Doppler Imaging (TDI)
- Tissue Harmonic Imaging (THI)

Images and clips storage

Internal storage: The number of images and clips you can save depends on imaging mode and file format.

Accessories

The following items are either included with or available for use on the ultrasound system.

- Battery
- Biopsy Guide
- Carry case
- ECG cable (6 ft/1.8 m)
- External display
- Footswitch
- Mini-Dock
- Mobile Docking System M Series (MDSm)
- Mobile Docking System Lite II (MDS Lite II)
- Needle Guide
- Power supply
- SiteLink Image Manager
- SonoCalc IMT
- System AC power cord (10 ft/3.1 m)
- Triple Transducer Connect

Peripherals

See the manufacturer's specifications for the following peripherals.

Medical grade

- Black-and-white printer
Recommended sources for printer paper: Contact Sony at 800-686-7669 or www.sony.com/professional to order supplies or to find the local distributor.
 - Color printer
 - DVD recorder
-

Non-medical grade Kensington Security Cable

Temperature and humidity limits

Note: The temperature, pressure, and humidity limits apply only to the ultrasound system, transducers, and battery.

Operating limits

System	Battery	Transducer
10–40°C (50–104°F), 15–95% R.H.	10–40°C (50–104°F), 15–95% R.H.	10–40°C (50–104°F), 15–95% R.H.
700 to 1060hPa (0.7 to 1.05 ATM)	700 to 1060hPa (0.7 to 1.05 ATM)	

Shipping and storage limits

System without Battery	Battery	Transducer
-35–65°C (-31–149°F), 15–95% R.H.	-20–60°C (-4–140°F), 15–95% R.H.*	-35–65°C (-31–149°F), 15–95% R.H.
500 to 1060hPa (0.5 to 1.05 ATM)	500 to 1060hPa (0.5 to 1.05 ATM)	

* For storage longer than 30 days, store at or below room temperature.

Electrical

Power Supply Input	100-240 VAC, 50/60 Hz, 2.0 A Max @ 100 VAC
Power Supply Output #1	15 VDC, 5.0 A Max
Power Supply Output #2	12 VDC, 2.3 A Max

Battery

The battery comprises six lithium-ion cells plus electronics, a temperature sensor, and battery contacts.

Run time is up to two hours, depending on imaging mode and display brightness.

Electromechanical safety standards

EN 60601-1:1997, European Norm, Medical Electrical Equipment–Part 1. General Requirements for Safety.

EN 60601-1-1:2001, European Norm, Medical Electrical Equipment–Part 1. General Requirements for Safety–Section 1-1. Collateral Standard. Safety Requirements for Medical Electrical Systems.

EN 60601-2-37:2001 + Amendment A1:2005, European Norm, Particular requirements for the safety of ultrasonic medical diagnostic and monitoring equipment.

CAN/CSA C22.2, No. 601.1-M90, Canadian Standards Association, Medical Electrical Equipment–Part 1. General Requirements for Safety (including CSA 601.1 Supplement 1:1994 and CSA 601.1 Amendment 2:1998).

CEI/IEC 61157:1992, International Electrotechnical Commission, Requirements for the Declaration of the Acoustic Output of Medical Diagnostic Ultrasonic Equipment.

UL 60601-1 (1st Edition), Underwriters Laboratories, Medical Electrical Equipment-Part 1: General Requirements for Safety.

EMC standards classification

EN 60601-1-2:2001, European Norm, Medical Electrical Equipment. General Requirements for Safety-Collateral Standard. Electromagnetic Compatibility. Requirements and Tests.

CISPR11:2004, International Electrotechnical Commission, International Special Committee on Radio Interference. Industrial, Scientific, and Medical (ISM) Radio-Frequency Equipment Electromagnetic Disturbance Characteristics-Limits and Methods of Measurement.

The Classification for the ultrasound system, docking system, accessories, and peripherals when configured together is: Group 1, Class A.

Airborne equipment standards

RTCA/DO-160E:2004, Radio Technical Commission for Aeronautics, Environmental Conditions and Test Procedures for Airborne Equipment, Section 21.0 Emission of Radio Frequency Energy, Category B.

DICOM standard

NEMA PS 3.15: 2000, Digital Imaging and Communications in Medicine (DICOM)-Part 15: Security Profiles.

HIPAA standard

The Health Insurance and Portability and Accountability Act, Pub.L. No. 104-191 (1996).

45 CFR 160, General Administrative Requirements.

45 CFR 164, Security and Privacy.

Glossary

Terms

For ultrasound terms not included in this glossary, refer to *Recommended Ultrasound Terminology, Second Edition*, published in 1997 by the American Institute of Ultrasound in Medicine (AIUM).

as low as reasonably achievable (ALARA)	The guiding principle of ultrasound use, which states that you should keep patient exposure to ultrasound energy as low as reasonably achievable for diagnostic results.
curved array transducer	Identified by the letter C (curved or curvilinear) and a number (60). The number corresponds to the radius of curvature of the array expressed in millimeters. The transducer elements are electrically configured to control the characteristics and direction of the acoustic beam. For example, C15, C60e.
depth	Refers to the depth of the display. A constant speed of sound of 1538.5 meters/second is assumed in the calculation of echo position in the image.
<i>in situ</i>	In the natural or original position.
LCD	liquid crystal display
linear array transducer	Identified by the letter L (linear) and a number (38). The number corresponds to the radius of width of the array expressed in millimeters. The transducer elements are electrically configured to control the characteristics and direction of the acoustic beam. For example, L38.
mechanical index (MI)	An indication of the likelihood of mechanical bioeffects occurring; the higher the MI, the greater the likelihood of mechanical bioeffects. See Chapter 6, "Safety," for a more complete description of MI.
MI/TI	See <i>mechanical index (MI)</i> and <i>thermal index (TI)</i> .
NTSC	National Television Standards Committee. A video format setting. See also <i>PAL</i> .
PAL	Phase Alternating Line. A video format setting. See also <i>NTSC</i> .
phased array	A transducer designed primarily for cardiac scanning. Forms a sector image by electronically steering the beam direction and focus.

skinline	A depth on the display that corresponds to the skin/transducer interface.
SonoHD	A subset of the 2D imaging mode in which the 2D image is enhanced by reducing speckle noise artifact at tissue margins and improving contrast resolution by reducing artifacts and improving visualization of texture patterns within the image.
SonoMB	A subset of the 2D imaging mode in which the 2D image is enhanced by looking at a target from three angles and then merging or averaging the scanned data together to improve overall image quality and, in parallel, reducing noise and artifacts.
Tissue Doppler Imaging (TDI)	A pulsed wave Doppler technique used to detect myocardial motion.
thermal index (TI)	The ratio of total acoustic power to the acoustic power required to raise tissue temperature by 1°C under defined assumptions. See Chapter 6, "Safety," for a more complete description of TI.
TIB (bone thermal index)	A thermal index for applications in which the ultrasound beam passes through soft tissue and a focal region is in the immediate vicinity of bone.
TIC (cranial bone thermal index)	A thermal index for applications in which the ultrasound beam passes through bone near the beam entrance into the body.
TIS (soft tissue thermal index)	A thermal index related to soft tissues.
Tissue Harmonic Imaging	Transmits at one frequency and receives at a higher harmonic frequency to reduce noise and clutter and improve resolution.
transducer	A device that transforms one form of energy into another form of energy. Ultrasound transducers contain piezoelectric elements, which when excited electrically, emit acoustic energy. When the acoustic energy is transmitted into the body, it travels until it encounters an interface, or change in tissue properties. At the interface, an echo is formed that returns to the transducer, where this acoustic energy is transformed into electrical energy, processed, and displayed as anatomical information.
variance	Displays a variation in Color Doppler flow imaging within a given sample. Variance is mapped to the color green and is used to detect turbulence.

Abbreviations

Abbreviations in User Interface

Abbreviation	Definition
+/x	"+" Caliper/"x" Caliper Ratio
A	"A" Wave Peak Velocity
A PG	"A" Wave Peak Pressure Gradient
A2Cd	Apical 2 Chamber diastolic
A2Cs	Apical 2 Chamber systolic
A4Cd	Apical 4 Chamber diastolic
A4Cs	Apical 4 Chamber systolic
AAo	Ascending Aorta
Abd	Abdomen
abs	Absolute value
AC	Abdominal Circumference
ACA	Anterior Cerebral Artery
ACC	Acceleration Index
ACoA	Anterior Communicating Artery
ACS	Aortic Valve Cusp Separation
AFI	Amniotic Fluid Index
AI	Aortic Insufficiency
AI PHT	Aortic Insufficiency Pressure Half Time
AL	Atlas Loop
Ann D	Annulus Diameter
ANT F	Anterior Far
ANT N	Anterior Near
Ao	Aorta
AoD	Aortic Root Diameter

Abbreviations in User Interface (Continued)

Abbreviation	Definition
Apical	Apical View
APTD	Anteroposterior Trunk Diameter
AT	Acceleration (Deceleration) Time
AUA	Average Ultrasound Age
AV	Aortic Valve
AV Area	Aortic Valve Area
AVA	Aortic Valve Area
BA	Basilar Artery
Bifur	Bifurcation
BP	Blood Pressure
BPD	Biparietal Diameter
BPM	Beats per Minute
Bre	Breast
BSA	Body Surface Area
CCA	Common Carotid Artery
CI	Cardiac Index
CO	Cardiac Output
CPD	Color Power Doppler
Crd	Cardiac
CRL	Crown Rump Length
CW	Continuous Wave Doppler
D	Diameter
D Apical	Distance Apical
DCCA	Distal Common Carotid Artery
DECA	Distal External Carotid Artery

Abbreviations in User Interface (Continued)

Abbreviation	Definition
DICA	Distal Internal Carotid Artery
Dist	Distal
dP:dT	Delta Pressure: Delta Time
E	"E" Wave Peak Velocity
E PG	"E" Wave Peak Pressure Gradient
E/e'	E velocity = Mitral Valve E velocity divided by the annular e' velocity
E:A	E:A Ratio
ECA	External Carotid Artery
ECG	Electrocardiogram
ECICA	Extracranial Internal Carotid Artery
ECVA	Extracranial Vertebral Artery
EDD	Estimated Date of Delivery
EDD by AUA	Estimated Date of Delivery by Average Ultrasound Age
EDD by LMP	Estimated Date of Delivery by Last Menstrual Period
EDV	End Diastolic Velocity
EF	Ejection Fraction
EF:SLOPE	E-F Slope
EFW	Estimated Fetal Weight
Endo	Endocardial
Epi	Epicardial
EPSS	"E" Point Septal Separation
Estab. DD	Established Due Date
ET	Elapsed Time
FH	Femoral Head
FHR	Fetal Heart Rate

Abbreviations in User Interface (Continued)

Abbreviation	Definition
FL	Femur Length
FM (Right and Left)	Foramen Magnum (same as SO)
FTA	Fetal Trunk Area
GA	Gestational Age
GA by LMP	Gestational Age by Last Menstrual Period
GA by LMPd	Gestational Age by derived Last Menstrual Period
Gate	Depth of Doppler Gate
GS	Gestational Sac
Gyn	Gynecology
HC	Head Circumference
HR	Heart Rate
ICA	Internal Carotid Artery
IMT	Intima Media Thickness
IVRT	Iso Volumic Relaxation Time
IVS	Interventricular Septum
IVSd	Interventricular Septum Diastolic
IVSFT	Interventricular Septum Fractional Shortening
IVSs	Interventricular Septum Systolic
LA	Left Atrium
LA/Ao	Left Atrium/Aorta Ratio
LAT F	Lateral Far
LAT N	Lateral Near
LMP	Last Menstrual Period
LMPd	derived Last Menstrual Period
LV	Left Ventricular

Abbreviations in User Interface (Continued)

Abbreviation	Definition
LV Area	Left Ventricular Area
LV mass	Left Ventricular mass
LV Volume	Left Ventricular Volume
LVD	Left Ventricular diastolic
LVD	Left Ventricular Dimension
LVDd	Left Ventricular Dimension Diastolic
LVDFS	Left Ventricular Dimension Fractional Shortening
LVDs	Left Ventricular Dimension Systolic
LVEDV	Left Ventricular End Diastolic Volume
LVESV	Left Ventricular End Systolic Volume
LVET	Left Ventricular Ejection Time
LVO	Left Ventricular Opacification
LVOT	Left Ventricular Outflow Tract
LVOT Area	Left Ventricular Outflow Tract Area
LVOT D	Left Ventricular Outflow Tract Diameter
LVOT VTI	Left Ventricular Outflow Tract Velocity Time Integral
LVPW	Left Ventricular Posterior Wall
LVPWd	Left Ventricular Posterior Wall Diastolic
LVPWFT	Left Ventricular Posterior Wall Fractional Thickening
LVPWs	Left Ventricular Posterior Wall Systolic
LVs	Left Ventricular systolic
MB	SonoMB
MCA	Middle Cerebral Artery
MCCA	Mid Common Carotid Artery
MECA	Mid External Carotid Artery

Abbreviations in User Interface (Continued)

Abbreviation	Definition
MI	Mechanical Index
MICA	Mid Internal Carotid Artery
Mid	Middle
MM	M Mode
MR PISA	Mitral Regurgitation Proximal Iso Velocity Surface Area
MR/VTI	Mitral Regurgitation/Velocity Time Integral
Msk	Muscle
MV	Mitral Valve
MV Area	Mitral Valve Area
MV ERO	Mitral Valve Effective Regurgitant Orifice
MV PISA Area	Mitral Valve Proximal Iso Velocity Surface Area
MV Rate	Mitral Valve Rate
MV Regurgitant Fraction	Mitral Valve Regurgitant Fraction
MV Regurgitant Volume	Mitral Valve Regurgitant Volume
MV/VTI	Mitral Valve/Velocity Time Integral
MVA	Mitral Valve Area
Neo	Neonatal
Nrv	Nerve
NTSC	National Television Standards Committee
OA	Ophthalmic Artery
OB	Obstetrical
OFD	Occipital Frontal Diameter
Orb	Orbital
PAL	Phase Alternating Line
PCAp	Posterior Cerebral Artery Peak

Abbreviations in User Interface (Continued)

Abbreviation	Definition
PCCA	Proximal Common Carotid Artery
PCoA	Posterior Communicating Artery
PECA	Proximal External Carotid Artery
PGmax	Maximum Pressure Gradient
PGmean	Mean Pressure Gradient
PGr	Pressure Gradient
PHT	Pressure Half Time
PI	Pulsatility Index
PICA	Proximal Internal Carotid Artery
PISA	Proximal Isovelocity Surface Area
Plaq	Plaque
POST F	Posterior Far
POST N	Posterior Near
PRF	Pulse Repetition Frequency
Prox	Proximal
PSV	Peak Systolic Velocity
PV	Pulmonic Valve
PW	Pulsed Wave Doppler
Qp/Qs	Pulmonary blood flow divided by systemic blood flow
RA	Right Atrial (pressure)
RI	Resistive Index
RVD	Right Ventricular Dimension
RVDd	Right Ventricular Dimension Diastolic
RVDs	Right Ventricular Dimension Systolic
RVOT D	Right Ventricular Outflow Tract Diameter

Abbreviations in User Interface (Continued)

Abbreviation	Definition
RVOT VTI	Right Ventricular Outflow Tract Velocity Time Integral
RVSP	Right Ventricular Systolic Pressure
RVW	Right Ventricular Free Wall
RVWd	Right Ventricular Free Wall Diastolic
RVWs	Right Ventricular Free Wall Systolic
S	SonoHD
S/D	Systolic/Diastolic Ratio
SI	Stroke Index
Siphon	Siphon (internal carotid artery)
SM	Submandibular
SmP	Small Parts
SO	Suboccipital
Sup	Superficial
SV	Stroke Volume
TAM	Time Average Mean
TAP	Time Average Peak
TCD	Transcranial Doppler
TDI	Tissue Doppler Imaging
THI	Tissue Harmonic Imaging
TI	Thermal Index
TICA	Terminal Internal Carotid Artery
TO	Transorbital
TRmax	Tricuspid Regurgitation (peak velocity)
TT	Transtemporal
TTD	Transverse Trunk Diameter

Abbreviations in User Interface (Continued)

Abbreviation	Definition
TV	Tricuspid Valve
UA	Ultrasound Age
Umb A	Umbilical Artery
VA	Vertebral Artery
VA _{rt}	Vertebral Artery
Vas	Vascular
Ven	Venous
VF	Volume Flow
V _{max}	Peak Velocity
V _{mean}	Mean Velocity
Vol	Volume
VTI	Velocity Time Integral

Index

Symbols

+/ x measurement 59

Numerics

2D imaging 34

2D options 35

A

A & B shortcut keys 17

abbreviations 181

abdominal, intended uses 2

AC power indicator 10

acceleration (ACC) index 59

accessories list 174

acoustic measurement precision 149

acoustic output

measurement 129

tables 131–??, 148

acquisition error 157

add new user 19

Administrator 18

age, gestational 86

airborne equipment standards 176

ALARA principle 122, 123, 179

alphanumeric keys 9

angle correction 39, 40

annotations

keys 9

place 43

predefine label groups 22

setup 22

aorta (Ao) 73

aortic valve area (AVA) 77

arrow graphic 44

ascending aorta (AAo) 73

audio 23

B

baseline 41

battery

clean 102

safety 116

setup 23

specifications 175

biological safety 117

biopsy 36

bodymarker. *See* pictographs

brightness 36

C

cables

clean and disinfect ECG 102

clean and disinfect transducer 101

connect power 6

calculations

authors 86

cardiac. *See* cardiac calculations

delete measurement 62, 63

general 61

gynecology (Gyn) 79

IMT 80

menu 12, 61

OB 83

percent area 64

percent diameter 64

percent reduction 63

perform measurement 62

performing 62

repeat measurement 62

save 62

small parts 89

specialized 68

vascular 90

view measurement 62

volume 65

volume flow 66

calipers 55

cardiac calculations

AAo 73

Ao 73

AVA 77

CI 78

CO 78

dP:dT 76

HR 78

IVRT 71

LA 73

LV volume (Simpson's Rule) 73

- LVd 72
- LVOT D 73
- LVs 72
- MV/AV area 73
- overview 68
- PHT 75
- PISA 70
- Qp/Qs 70
- RVSP 75
- setup 23
- SV 78
- TDI 79
- VTI 74
- cardiac index (CI) 78
- cardiac output (CO) 78
- cardiac references 157
- cardiac, intended uses 2
- cautions, definition vii
- cine buffer 10, 34
- clean
 - battery 102
 - ECG cable 102
 - footswitch 102
 - LCD screen 98
 - system 98
 - transducer cables 101
 - transducers 99
- clip acquisition delay 53
- clips
 - See also* images and clips
 - options 36, 49
- color Doppler (Color) imaging 37
- color power Doppler (CPD) imaging 37
- color scheme, background 30
- color suppress 38
- Color. *See* color Doppler (Color) imaging
- connectivity setup 24
- continuous wave (CW) Doppler imaging 39, 40
- controls
 - direct 123
 - indirect 124
 - receiver 124
- CPD. *See* color power Doppler (CPD) imaging
- customer assistance vii
- CW Doppler. *See* continuous wave (CW) Doppler imaging

D

- date 25

- default settings 31
- delta pressure:delta time (dP:dT) 76
- depth
 - adjust 33
 - definition 179
 - keys 9
 - marker 13
- DICOM standard 176
- dimensions, system and display 173
- disinfect
 - battery 102
 - ECG cable 102
 - system 98
 - transducer cables 101
 - transducers 99
- disinfectants, compatibility 104
- display setup 25
- distance measurements
 - 2D 57
 - M mode 58
- D-line 39
- Doppler
 - measurements 59
 - scale setup 29
- dual images 35
- duplex 29
- DVD recorder 24, 95
- Dynamic Range 30

E

- ECG
 - Monitoring 36, 52
 - options 53
- elapsed time (ET) measurement 59
- electrical
 - safety 113
 - specifications 175
- electromagnetic compatibility 118
- electromechanical safety standards 176
- EMC classification standards 176
- EMED worksheets 94
- equipment safety 116
- error message 115
- errors
 - acquisition 157
 - algorithmic 157
 - measurement 157
- estimated date of delivery (EDD) 164
- estimated fetal weight (EFW) 164

Event log 20
exam
 change type 34
 end 46
 type and transducer 42
export and import
 OB calculation tables 27
 predefined label groups 22
 user accounts 20

F

far 10
fetal heart rate (FHR) 88
flow sensitivity 38
focal zones, optimize 35
footswitch setup 17
forms 10
freeze 33

G

gain
 adjust 33
 ECG 53
 knob 10
gate size 40
gestational age
 setup 27
 tables, references 165
gestational growth, measure 87
grace period 96
grayscale 35
growth analysis
 setup 27
 tables, references 167
guidance documents, related 127
guideline 36
gynecology, intended uses 3

H

heart rate 47
heart rate (HR) 58, 78, 88
HIPAA standard 177
home position 44
humidity limits 175

I

image quality, poor 95
images and clips
 archive 52
 delete 52
 export to USB 52
 review 51
imaging modes
 list of 173
 transducer 42
import. *See* export and import
IMT. *See* Intima Media Thickness (IMT)
in situ, definition 179
infertility, intended uses 3
intended uses 2–4
intensity
 derated 129
 in situ 129
 water-value 129
interventional, intended uses 3
Intima Media Thickness (IMT)
 calculations 25, 80
 sketch 83
 trace 83
intraoperative, intended uses 3
invert
 Color 38
 spectral trace 41
iso volumic relaxation time (IVRT) 71

K

keys 9
knobs 9

L

labeling symbols 150
language 30
layout 29
LCD screen
 clean 98
 output 127
left atrium (LA) 73
left ventricular diastolic (LVd) 72
left ventricular outflow tract diameter (LVOT D) 73
left ventricular systolic (LVs) 72
left ventricular volume (LV volume) 73
license key 96
live trace 30, 41

login
Administrator 18
user 18
LVO (Left Ventricular Opacification) 35

M

M Mode imaging 36
maintenance 97
measurements
 See also calculations
 +/- Ratio, Doppler 59
 2D 56
 about 55
 Acceleration, Doppler 59
 accuracy 55, 155
 area, 2D 57
 automatic trace, Doppler 60
 circumference, 2D 57
 delete 56
 distance, 2D 57
 distance, M Mode 58
 Doppler 59
 edit 56
 Elapsed Time, Doppler 59
 errors 157
 fetal heart rate 88
 heart rate 58, 88
 M Mode 58
 manual trace 58, 59
 Pressure Gradient, Doppler 59
 publications 157
 Resistive Index, Doppler 59
 save to calculation and report 55
 terminology 157
 vascular 90
 Velocities, Doppler 59
mechanical index (MI) 127, 179
mitral valve/aortic valve (MV/AV) 73
M-line 36
mode data 12, 25
modes, keys 11

N

near 10
network 26
NTSC
 definition 179
 option 24

O

OB
 calculations 26, 83
 custom measurements setup 27
 custom tables setup 28
 graphs 94
 intended uses 3
 references 164
 tables setup 28
on-screen controls 10
optimize 35
orientation
 marker 12
 option 35
output display 127

P

PAL
 definition 179
 option 24
password 19, 20, 21
patient header 13, 25
patient information form 45
patient list 50
patient report
 about 92
 cardiac 92
 general 92
 OB 92
 save measurement to 55
 vascular 92
PC 24
pediatric, intended uses 3
percent reduction calculation 63
peripherals 174
pictographs
 PICTO key 12
 placing 45
power delay 23
power key 9
precision, acoustic measurement 149
preferences 29
presets 29
pressure half time (PHT) 75
pressure limits 175
PRF 38, 41
print 51
printer
 problem 95

- setup 24
- probe. *See* transducer
- prostate, intended uses 4
- proximal isovelocity surface area (PISA) 70
- pulsed wave (PW) Doppler imaging 39
- PW Doppler. *See* pulsed wave (PW) Doppler imaging

Q

- Qp/Qs 70

R

- recording problem 95
- references
 - cardiac 157
 - general 169
 - gestational age tables 165
 - growth analysis tables 167
 - obstetrical 164
 - ratio calculations 169
- report, patient 92
- resistive index (RI) measurement 59
- right ventricular systolic pressure (RVSP) 75

S

- safety
 - battery 116
 - biological 117
 - electrical 113
 - electromagnetic compatibility 118
 - equipment 116
- save
 - calculations 62
 - image 10
 - measurements 55
- SAVE key 30
- scale 41
- scanhead. *See* transducer
- screen layout 12
- security 18
- serial port 24
- setup pages 17
- shipping specifications 175
- shortcut keys 17
- Simpson's Rule 73
- skin line, definition 180
- sleep delay 23
- small parts calculations 89

- software license 96
- SonoHD 36, 180
- SonoMB 36, 180
- specifications 173
- spectral trace 39
- standards
 - airborne equipment 176
 - DICOM 176
 - electromechanical 176
 - EMC classification 176
 - HIPAA 177
- steering
 - CPD 38
 - Doppler 40
- storage specifications
 - equipment 175
 - images 174
- stroke volume (SV) 78
- superficial, intended uses 4
- sweep speed
 - Doppler 41
 - ECG 53
 - M Mode 37
- symbols, labeling 150
- system
 - clean and disinfect 98
 - controls 9
 - software 2
 - status 13, 25
 - wake up 6

T

- Technical Support viii
- temperature limits 175
- text 44
- text description 12
- thermal index (TI) 30, 127, 180
- THI 36
- time setup 25
- tissue Doppler imaging (TDI) 40, 79
- tissue models 130
- touchpad 10, 13
- transducer
 - cables, clean and disinfect 101
 - clean and disinfect 99
 - curved array 179
 - definition 180
 - disinfect 99
 - exam type 42

- general use 16
- imaging modes 42
- invasive or surgical use 16
- linear array 179
- preparation 16
- problems 96
- specifications 173

troubleshoot 95

U

- ultrasound terminology 179
- unfreeze text 22
- USB storage device, export to 52
- user account 20
- user guide, conventions used vii
- user setup 19
- uses, intended 2–4

V

- variance 38
- vascular
 - calculations 90
 - intended uses 4
- velocity measurement 59
- velocity time integral (VTI) 74
- volume
 - calculation 65
 - Doppler, adjust 41
- volume flow 66

W

- wall filter 38, 41
- warnings, definition vii
- worksheets, EMED 94

Z

- zoom 34





P07662-01

