

OPERATOR'S MANUAL

66260X

INCLUDING: OPERATION, INSTALLATION & MAINTENANCE
INCLUDE MANUAL: 6564X-X AIR MOTOR (97999-174), AIRLINE SAFETY INFORMATION (100400-76)
& S-633 GENERAL INFORMATION (PN 97999-624).

RELEASED: 8-26-09
REVISED: 3-17-10
(REV. G)

**6" AIR MOTOR
100:1 RATIO
0 - 10,000 PSI. RANGE**

**662605, 662606, 662608 & 662609
PUMP ASSEMBLY**



**READ THIS MANUAL CAREFULLY BEFORE INSTALLING,
OPERATING OR SERVICING THIS EQUIPMENT.**

It is the responsibility of the employer to place this information in the hands of the operator. Keep for future reference.

SERVICE KITS

- Use only genuine ARO® replacement parts to assure compatible pressure rating and longest service life.
- **65130** packing kit.
- **61355** for air motor service only.

SPECIFICATIONS

Model Series 662605, 662606, 662608 & 662609.
Type Air Operated Grease Pump
Ratio 100:1
Air Motor Diameter 6" (15.2 cm)
Stroke 4" (10.2 cm)
Air Inlet (female) 1/2-14 N.P.T.F.
Material Outlet (female) 1/2 - 14 N.P.T.F.
Dimensional Data see chart

PERFORMANCE

Air Inlet Pressure Range 0 - 100 p.s.i.g (0 - 6.9 bar)
Fluid Pressure Range 0 - 10,000 p.s.i.g (0 - 690 bar)
Maximum Delivery/ Min 2.1 lbs (0.95 kg)

OPERATING AND SAFETY PRECAUTIONS

⚠ WARNING READ THE GENERAL INFORMATION MANUAL INCLUDED FOR ADDITIONAL OPERATING AND SAFETY PRECAUTIONS AND OTHER IMPORTANT INFORMATION.

⚠ WARNING EXCESSIVE INLET PRESSURE. Can cause explosion resulting in severe injury or death. Do not exceed maximum operating pressure of 10,000 p.s.i.g (690 bar) at 100 p.s.i.g (6.9 bar) inlet air pressure. Do not run pump without using a regulator to limit air supply pressure to the pump.

⚠ WARNING EXCESSIVE MATERIAL PRESSURE. Can cause equipment failure resulting in severe injury or property damage. Do not exceed the maximum material pressure of any component in the system.

PUMP RATIO X INLET PRESSURE TO PUMP MOTOR	=	MAXIMUM PUMP FLUID PRESSURE
Pump ratio is an expression of the relationship between the pump motor area and the lower pump end area. EXAMPLE: When 100 p.s.i.g (6.9 bar) inlet pressure is supplied to the motor of a 100:1 ratio pump it will develop a maximum of 10,000 p.s.i.g (690 bar) fluid pressure (at no flow) - as the fluid control is opened, the flow rate will increase as the motor cycle rate increases to keep up with the demand.		

NOTICE Thermal expansion can occur when the fluid in the material lines is exposed to elevated temperatures. Example: Material lines located in a non-insulated roof area can warm due to sunlight. Install a pressure relief valve in the pumping system.

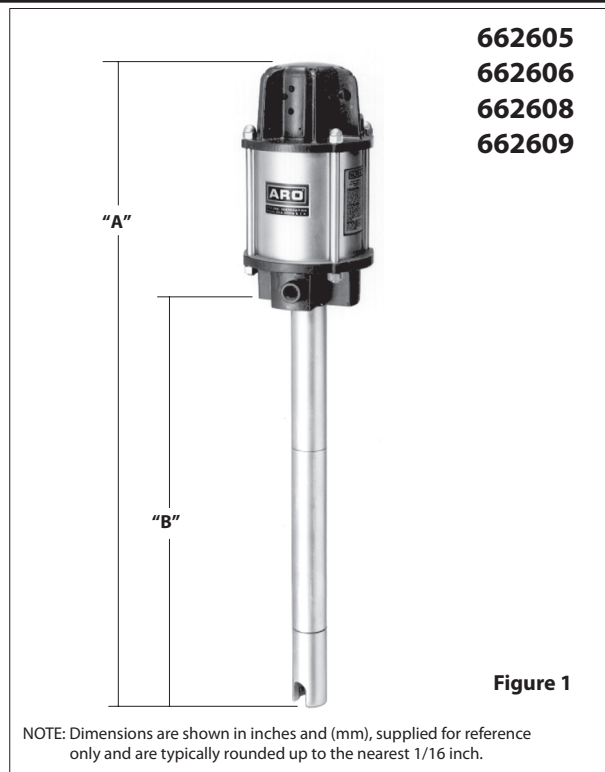

MODELS	"A" (mm)	"B" (mm)	Drum Size
662605, 662606	39-5/8" (1006)	25-7/16" (646)	120 lb.
662608, 662609	49-7/16" (1256)	35-1/4" (895)	400 lb. (55 gal.)

IMPORTANT

This is one of four documents which support the pump. Replacement copies of these forms are available upon request.

- 66260X MODEL OPERATOR'S MANUAL
- 6564X-X AIR MOTOR OPERATOR'S MANUAL
- 100400-76 AIRLINE SAFETY INFORMATION MANUAL
- S-633 GENERAL INFORMATION LUBRICATION PISTON PUMPS

ARO

IR Ingersoll Rand
Industrial Technologies

PARTS LIST / LOWER PUMP END

Item	Description (size in inches)	Qty	Part No.
1	Tube (662605 & 662606)	(1)	92625-1
	(662608 & 662609)	(1)	92625-2
2	Rod (662605 & 662606)	(1)	92629-1
	(662608 & 662609)	(1)	92629-2
3	Adapter	(1)	92621
4	Pin	(1)	92624
5	Ball Guide	(1)	92623
6	Ball	(1)	Y16-211
7	Piston and Cylinder	(1)	66714
8	Gasket	(1)	92628
9	Tube	(1)	92627
10	Primer Rod	(1)	90131
11	Washer	(1)	90136
12	Foot Valve Sleeve	(1)	4170
13	Snap Ring	(1)	Y147-77
14	Cup	(1)	90757
15	Body	(1)	90756
16	Washer	(1)	F21-56
17	Foot Valve Seat	(1)	93269-1
18	Washer	(1)	90133
19	Washer	(1)	92630
20	Elastic Stop Nut	(1)	95977302
21	Primer Tube	(1)	92626

INSTALLATION

Remove pump from packaging material and install and secure pump to cover, bung or other mounting accessory as ordered. See figure 2 for view of complete assembly.

1. Before connecting pump, first blow out material line with air.
2. After the system is hooked up, pump a small amount of material through the line. This material should be discarded. (Do this to clear any foreign material out of lines).

OPERATING INSTRUCTIONS

Be sure material hose, lines and other components are able to withstand pressure developed by pumps.

1. When a pump is installed and ready to operate: Connect air supply to air motor inlet. Regulate air pressure from p.s.i.g (2.07 bar) to 50 p.s.i.g (3.4 bar). Allow pump to cycle slowly to prime with material and bleed all air from system.

MAINTENANCE

If the pump is to be inoperative for a lengthy period of time (a few hours), disconnect air and relieve all pressure from system. Periodically flush pump with a solvent that is compatible with material being pumped.

Disassembly should be done on a clean work bench with clean cloths to keep parts clean.

If replacement parts are necessary, consult drawings containing parts for identification.

Before reassembling, lubricate parts where required. When assembling "O" rings or parts adjacent to "O" rings, care must be exercised to prevent damage to "O" rings and "O" ring groove surfaces.

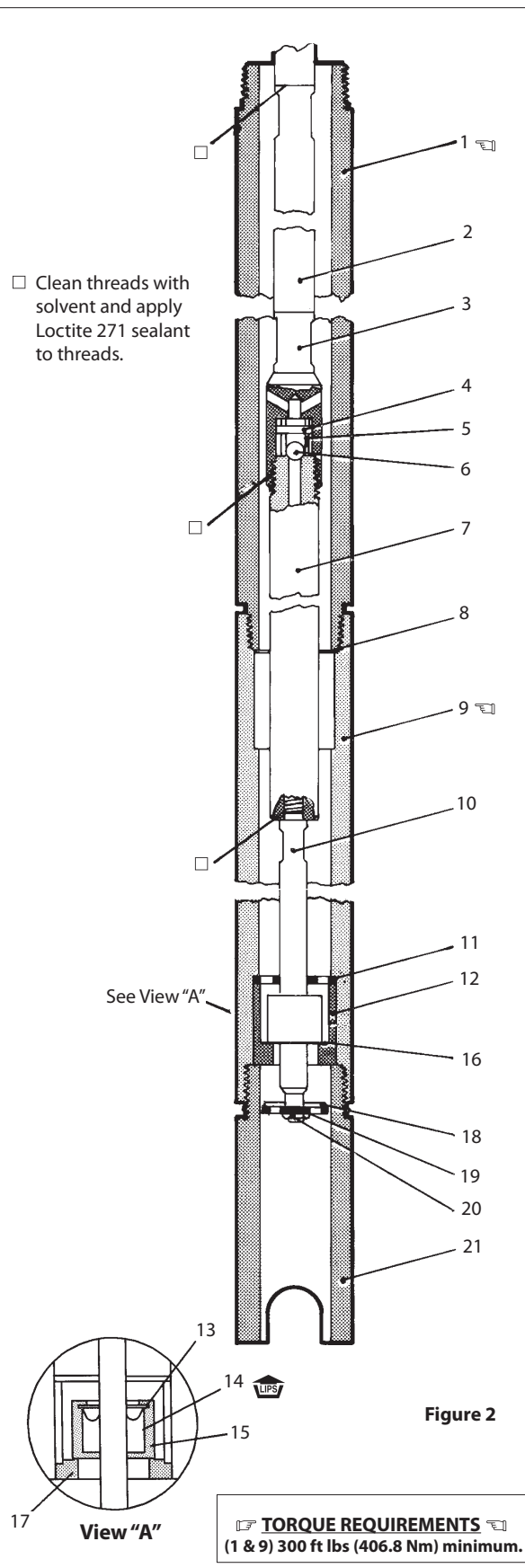

Figure 2

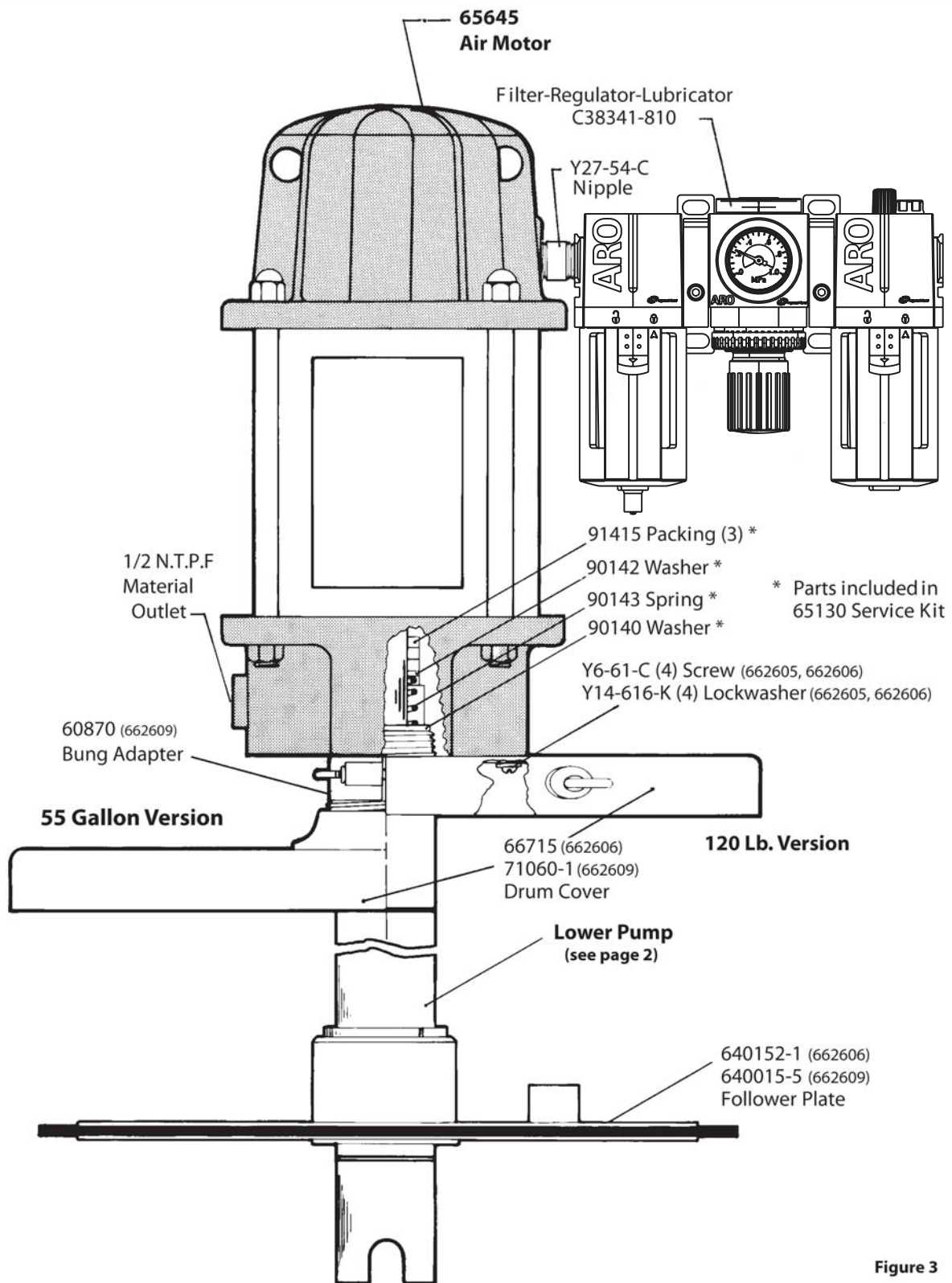

Figure 3

TROUBLE SHOOTING

No material at outlet. (Pump continuously cycles).

- Empty material supply. Disconnect the air, replenish the material supply.
- Foreign matter is holding foot valve seats open in lower pump tube assembly. Remove lower pump tube assembly and clean valve seats.

Pump operates sluggishly, tends to stick when air is applied or control is opened.

- Air motor is dirty or lacks lubrication. Clean air motor.
- Insufficient air pressure or volume of air. Check air supply.

Air bypasses through exhaust port.

- Foreign matter is holding air valve open or lacks lubrication. Consult factory for nearest Service Center.

Motor stalls.

- Foreign matter in pump, hose, control valve or spray tip obstructing material flow. Check material supply hose and control valve or tip.
- Air not getting to pump. Check air supply.