

NHP SAFETY REFERENCE GUIDE

GSR

NHP

SAFETY FUNCTION DOCUMENTS

2 Hand Control
Safety Function



Authorised
Distributor

Safety Function Documents: GSR

Two Hand Control Products: 800Z Zero Force Buttons / MSR125 Safety Relay / GSR SI Safety Relay

Safety Rating: PLd, Cat. 3 to EN ISO 13849.1 2008

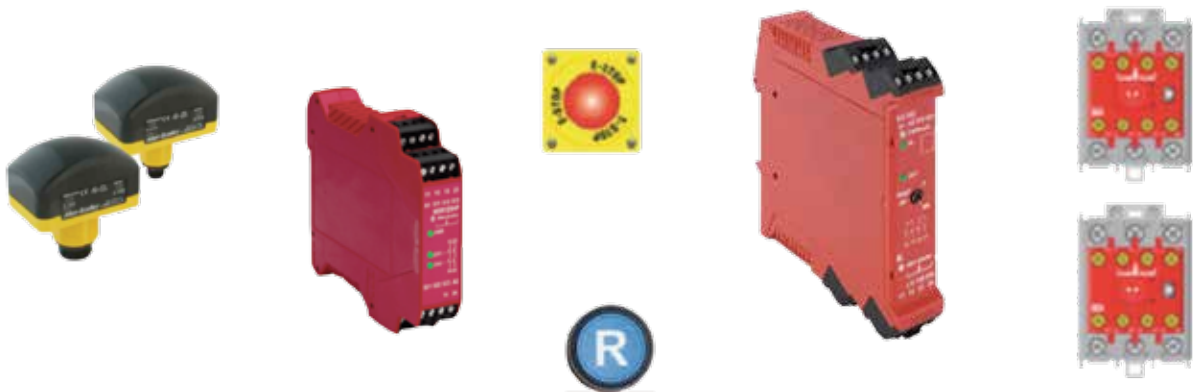

Table of Contents:

Introduction	6-3
Important User Information	6-3
Safety Function Realization	6-4
General Safety Information	6-5
Setup and Wiring	6-7
Configuration	6-8
Calculation of PFHd	6-9
Verification and Validation Plan	6-12
Additional Resources	6-15

Safety Function Documents: GSR

Two Hand Control Products: 800Z Zero Force Buttons / MSR125 Safety Relay / GSR SI Safety Relay

Safety Rating: PLd, Cat. 3 to EN ISO 13849.1 2008

Introduction

This Safety Function application note explains how to wire and configure two 800Z zero force palm buttons, an MSR 125 two hand control, an E-Stop, a GSR SI Safety Relay and two 100S safety contactors to create a two hand control safety system. When the operator places one hand on each button simultaneously (within 0.5 sec. of each other), confirming that the operator is in the proper, safe location, the two 100s contactors are energized powering the hazardous motion. Removing either or both hands will cause the system to turn off the safety contactors.

The SISTEMA calculations in this document are for the system described here. A system using different components or a different configuration would have to be calculated based on its actual components and system structure.

Important User Information

Solid state equipment has operational characteristics differing from those of electromechanical equipment. Safety Guidelines for the Application, Installation and Maintenance of Solid State Controls (publication SGI-1.1 available from your local Rockwell Automation® sales office or online at <http://www.rockwellautomation.com/literature>) describes some important differences between solid state equipment and hard-wired electromechanical devices. Because of this difference, and also because of the wide variety of uses for solid state equipment, all persons responsible for applying this equipment must satisfy themselves that each intended application of this equipment is acceptable.

In no event will Rockwell Automation, Inc. be responsible or liable for indirect or consequential damages resulting from the use or application of this equipment.

The examples and diagrams in this manual are included solely for illustrative purposes.

Because of the many variables and requirements associated with any particular installation, Rockwell Automation, Inc. cannot assume responsibility or liability for actual use based on the examples and diagrams.

No patent liability is assumed by Rockwell Automation, Inc. with respect to use of information, circuits, equipment, or software described in this manual.

Reproduction of the contents of this manual, in whole or in part, without written permission of Rockwell Automation, Inc., is prohibited.

Safety Function Documents: GSR

Two Hand Control Products: 800Z Zero Force Buttons / MSR125 Safety Relay / GSR SI Safety Relay

Safety Rating: PLd, Cat. 3 to EN ISO 13849.1 2008

Safety Function Realization: Risk Assessment

The required performance level is the result of a risk assessment and refers to the amount of the risk reduction to be carried out by the safety-related parts of the control system. Part of the risk reduction process is to determine the safety functions of the machine. For the purposes of this document the assumed performance level required (PLr) is PLd, Category 3.

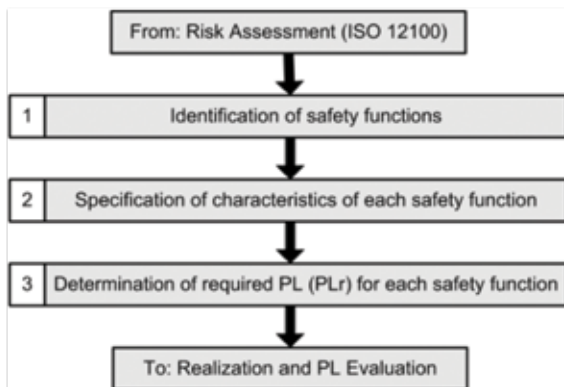

Two Hand Control Safety Function

The safety system described in this Safety Function application note contains two safety functions.

1. Two Hand Monitoring Safety Function: Power is provided to the hazard only when the operator's hands have been placed on the palm buttons simultaneously and remain on the buttons. Power is removed when one or either hand is removed from its palm button.
2. E-Stop Safety Function: The removal of power from the hazard when the safety system detects that the E-Stop has been actuated.

Safety Function Requirements

Two Hand Monitoring Safety Function: Controlled location of an operator's hands during hazardous motion by requiring the continuous actuation of two palm buttons to enable power to the motor. Simultaneity of operation of the two buttons must be within 0.5 seconds per ISO 13851. Upon releasing either or both of the two palm buttons, power to the motor will be removed. Placing both hands on the palm buttons simultaneously will restart the hazardous motion.

Faults at the two-hand palm buttons, wiring terminals or safety controller will be detected before the next safety demand. The safe distance location of the two-hand control station must be established per ISO 13855 such that the hazardous motion must be stopped before the operator can reach the hazard.

E-Stop Safety Function: Pressing the E-Stop will stop hazardous and prevent motion by removal of power to the motor. Upon resetting the E-Stop pushbutton, hazardous motion and power to the motor will not resume until a secondary action, pressing and releasing the reset button, is performed. This Emergency Stop function is complementary to any other safeguards on the machine and shall not reduce the performance of other safety related functions.

The safety functions in this example are each capable of connecting and interrupting power to motors rated up to 9A, 600VAC. The safety functions will meet the requirements for Performance Level "d", Category 3 (PLd, Cat 3), per ISO 13849-1, and SIL3 per IEC 62061, and control reliable operation per ANSI B11.19. The stop implemented by each safety function is Stop Category 0.

Safety Function Documents: GSR

Two Hand Control Products:

800Z Zero Force Buttons / MSR125 Safety Relay / GSR SI Safety Relay

Safety Rating: PLd, Cat. 3 to EN ISO 13849.1 2008

Safety Function Requirements (cont)

Throughout this manual, when necessary, we use notes to make you aware of safety considerations.

	<p>WARNING: Identifies information about practices or circumstances that can cause an explosion in a hazardous environment, which may lead to personal injury or death, property damage, or economic loss.</p>
<p>IMPORTANT</p>	<p>Identifies information that is critical for successful application and understanding of the product.</p>
	<p>ATTENTION: Identifies information about practices or circumstances that can lead to personal injury or death, property damage, or economic loss. Attentions help you identify a hazard, avoid a hazard, and recognize the consequence.</p>
	<p>SHOCK HAZARD: Labels may be on or inside the equipment, for example, a drive or motor, to alert people that dangerous voltage may be present.</p>
	<p>BURN HAZARD: Labels may be on or inside the equipment, for example, a drive or motor, to alert people that surfaces may reach dangerous temperatures.</p>

General Safety Information

Contact NHP to find out more about our safety risk assessment services.

<p>IMPORTANT</p>	<p>This application example is for advanced users and assumes that you are trained and experienced in safety system requirements.</p>
	<p>ATTENTION: A risk assessment should be performed to make sure all task and hazard combinations have been identified and addressed. The risk assessment may require additional circuitry to reduce the risk to a tolerable level. Safety circuits must take into consideration safety distance calculations which are not part of the scope of this document.</p>

Safety Function Documents: GSR

Two Hand Control Products: 800Z Zero Force Buttons / MSR125 Safety Relay / GSR SI Safety Relay

Safety Rating: PLd, Cat. 3 to EN ISO 13849.1 2008

Functional Safety Description

The purpose of the two hand monitoring safety function in this application note is to provide safe and easy running and stopping of a hazardous machine to suit the requirements of a manufacturing process. The machine is allowed to run, performing its task, while then operator is in a safe location with both the operator's hands are placed, one on each of two palm buttons. When either one or both of the operator's hands are removed from a palm button the MSR 125 responds by opening its safety contacts removing power to the hazardous motion stopping the machine to allow the operator to perform some safe task in the guarded area while the machine is stopped and maintained stopped. Once this task is completed the operator must move a distance away from the guarded area to access the two palm buttons. The operator must place their hands on the two palm buttons, simultaneously. Responding to this, the MSR 125 responds by closing its safety contacts. This starts the machine allowing it to perform its task.

The purpose of the E-Stop safety function is straightforward. When an urgent need to stop the machine arises the E-Stop pushbutton is pressed. The GSR SI monitoring the E-Stop pushbutton responds by opening its safety contacts removing power from the coils of the two 100S safety contactors. The 100s contacts open removing power from the hazardous motion.

Bill of Material

Catalog Number	Description	Quantity
800Z-GL2Q5Y	22.5 mm Type 4/4X/13 IP66 Zero-Force Momentary General Purpose Touch Button, 10-40V DC and 20-30V AC Input, Relay Output - 5 Pin QD, Yellow Guard	2
800Z-G2AH1	Plastic Mounting Kit for 22.5 mm Hole, (GP)	2
889D-F5AC-2	5 Pin Straight QD Cable, 22.5 mm Mounting Hole, 2 , Length	2
440R-D23171	MSR125 HP Relay Model, Two-Hand Control, 2 N.O. Immediate Safety Outputs, N/A Auxiliary Outputs, N/A Delayed Safety Outputs, 24V AC/DC Power Supply, Automatic/Manual Reset, Removable Terminals	1
440R-A23209	Bag of 4, 4-Pin Screw Terminal Blocks	1
800F-1YP3	800F 1-Hole Enclosure E-Stop Station, Plastic, PG, Twist-to-Release 40 mm, Non-Illuminated, 2 N.C.	1
440R-S12R2	Guardmaster® Safety Relay, 1 Dual Channel Universal Input, 1 N.C. Solid State Auxiliary Outputs	1
800FM-G611MX10	800F Push Button - Metal, Guarded, Blue, R, Metal Latch Mount, 1 N.O. Contact(s), 0 N.C. Contact(s), Standard, Standard Pack (Qty. 1)	1
100S-C09ZJ23C	MCS 100S-C Safety Contactor, 9A, 24V DC	2

Safety Function Documents: GSR

Two Hand Control Products:

800Z Zero Force Buttons / MSR125 Safety Relay / GSR SI Safety Relay

Safety Rating: PLd, Cat. 3 to EN ISO 13849.1 2008

Setup and Wiring

For detailed information on installing and wiring, refer to the product manuals listed on the Additional Resources page.

System Overview

The monitors the contacts of the two 800Z palm buttons. When the system is running and one hand, or both hands, move from a palm button the MSR 125 responds by opening its safety contacts removing 24V from the coils of both 100S contactors. The contactors open their contacts removing power from the hazardous motion. The hazardous motion coasts to a stop.

The MSR 125 is wired automatic reset. As required by standards, the MSR125 will only reset if both palm buttons are actuated by an operator's hands with 0.5 seconds of each other (simultaneity). When the standard's simultaneity requirement is met the MSR 125 closes its safety contacts provided that two auxiliary contacts of the 100S contactors K1 and K2, wired in series between Y1 and Y2 of the MSR125, are closed confirming that both 100Ss are properly de-energized. The closing safety contacts energize the coils of the 100S contactors. The hazardous motion is restarted.

The MSR 125 uses Plausibility check, e.g. use of normally open and normally closed mechanically linked contacts to monitor the 800Z palm buttons for faults.

The GSR SI monitors the E-Stop push button. The pulsed outputs of the GSR SI (terminals S11 and S21) are run separately through the two E-Stop contacts to input terminals S12 and S22 respectively. This enables the GSR SI to detect loose wire, short to 24V, short to GND, welded contact and cross channel faults.

When the E-Stop push button is pressed the pulsed output to input circuits are broken. The GSR SI responds by opening its safety contacts removing 24V from the coils of the 100S contactors. De-energized, the 100Ss open their contacts. The hazardous motion coasts to a stop.

The GSR-S is configured for monitored manual reset. 24V is connected to the reset button via two auxiliary NC contacts of the 100S contactors. The two closed NC contacts confirm that the 100S contactors are properly de-energized. Once the E-Stop button is released and the reset pushbutton is pressed for .250 to 3 seconds, then released, the GSR SI resets, closing its safety contacts. The hazardous motion is restarted.

When the reset button is pressed for less than .250 seconds or longer than 3 seconds the reset signal is ignored and the GSR SI safety contactors remain open. This is to prevent inadvertent reset and thwart tie down of the reset button.

Safety Function Documents: GSR

Two Hand Control Products: 800Z Zero Force Buttons / MSR125 Safety Relay / GSR SI Safety Relay

Safety Rating: PLd, Cat. 3 to EN ISO 13849.1 2008

Electrical Schematic

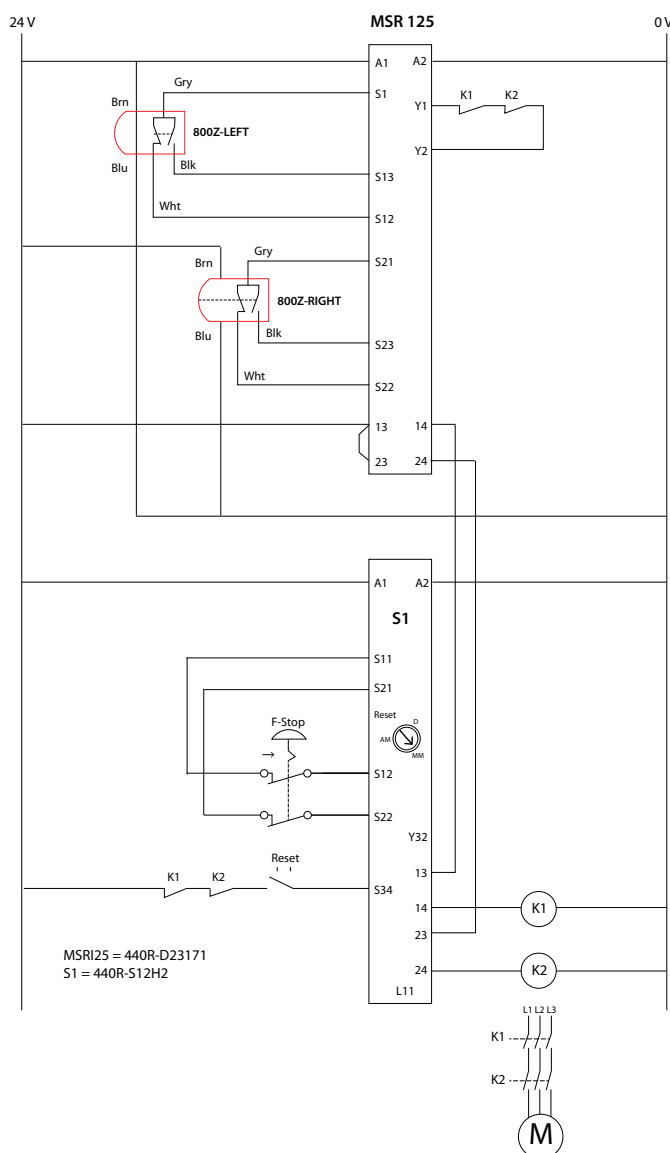

Configuration GSR SI

the following procedure sets the function of the device.

1. Start configuration to overwrite with power off turn rotary switch to position "0" and unit is powered up. After power-up test, "WR" LED will flash red.
2. Set configuration: turn rotary switch to "MM" (monitored manual) IN 1 LED blinks new setting. Note: position is set when "PWR" LED is solid green.
3. Lock in configuration by cycling unit power.
4. Configuration must be confirmed before operation. A white space on the face of the device is provided to record unit setting.

1 Enable program mode

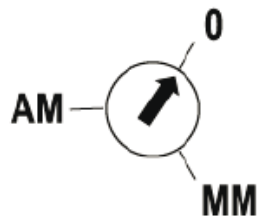

2 Set operation mode

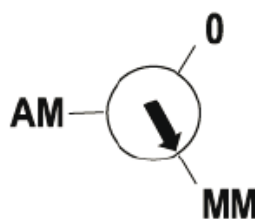

3 Cycle power to store

Safety Function Documents: GSR

Two Hand Control Products: 800Z Zero Force Buttons / MSR125 Safety Relay / GSR SI Safety Relay

Safety Rating: PLd, Cat. 3 to EN ISO 13849.1 2008

Calculation of PFHd

The Performance Level required (PLr) for each safety function in this application note project is PLd, Cat. 3. When configured correctly, the two safety functions project can achieve a safety rating of PLe, Cat.4 according to EN ISO 13849.1 2008.

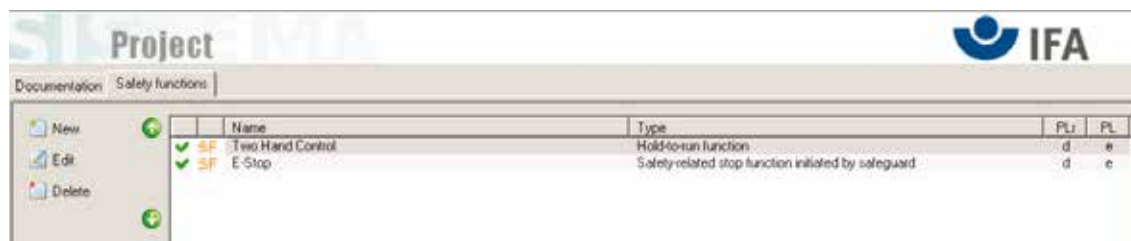

The overall Two Hand Control safety function value is shown below.

SF Two Hand Control	
PLr	d
PL	e
PFH [1/h]	5.85E-8

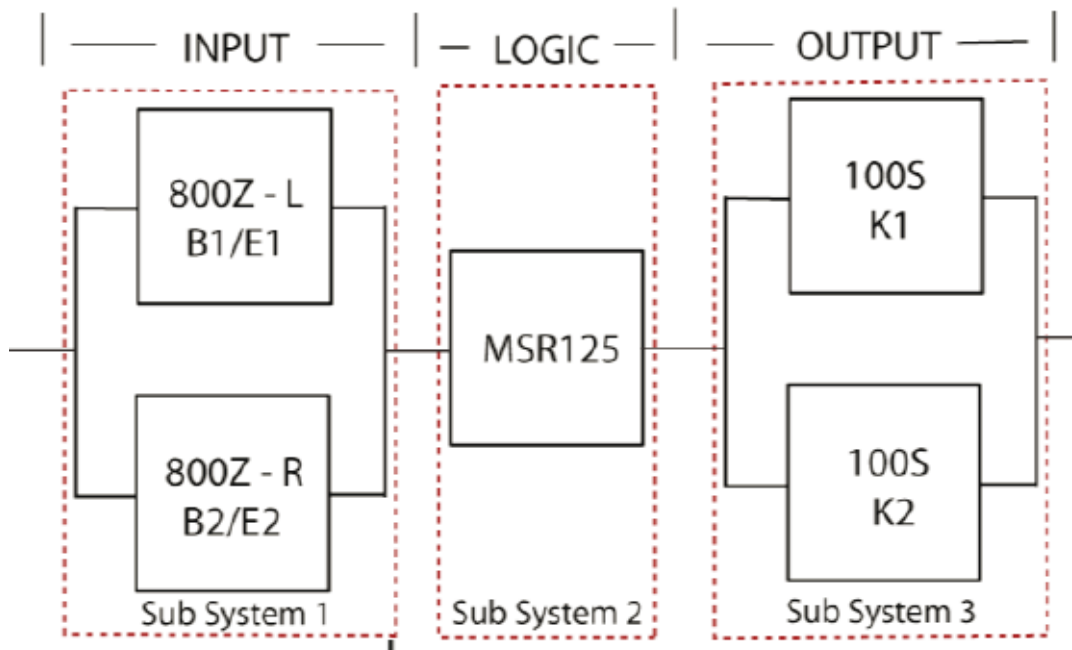

Safety Function Documents: GSR

Two Hand Control Products:

800Z Zero Force Buttons / MSR125 Safety Relay / GSR SI Safety Relay

Safety Rating: PLd, Cat. 3 to EN ISO 13849.1 2008

The functional safety ratings for the 800Z INPUT subsystem are:

SB Two Hand Buttons	
PL	e
PFH [1/h]	3.36E-8
Cat.	4
MTTFd [a]	76 (High)
DCavg [%]	99 (High)
CCF	65 (fulfilled)

The functional safety ratings for the MSR 125 LOGIC subsystem are:

SB Monitoring Safety Relay: MSR125	
PL	e
PFH [1/h]	2.45E-10
Cat.	4
MTTFd [a]	<i>not relevant</i>
DCavg [%]	<i>not relevant</i>
CCF	<i>not relevant</i>

The functional safety ratings for the 100S OUTPUT subsystem are:

SB 100S Safety Contactor	
PL	e
PFH [1/h]	2.47E-8
Cat.	4
MTTFd [a]	100 (High)
DCavg [%]	99 (High)
CCF	65 (fulfilled)

The overall E-Stop safety function value is shown below.

SF E-Stop	
PLr	d
PL	e
PFH [1/h]	5.33E-8

Safety Function Documents: GSR

Two Hand Control Products:

800Z Zero Force Buttons / MSR125 Safety Relay / GSR SI Safety Relay

Safety Rating: PLd, Cat. 3 to EN ISO 13849.1 2008

The E-Stop Safety function can be modeled as follows:

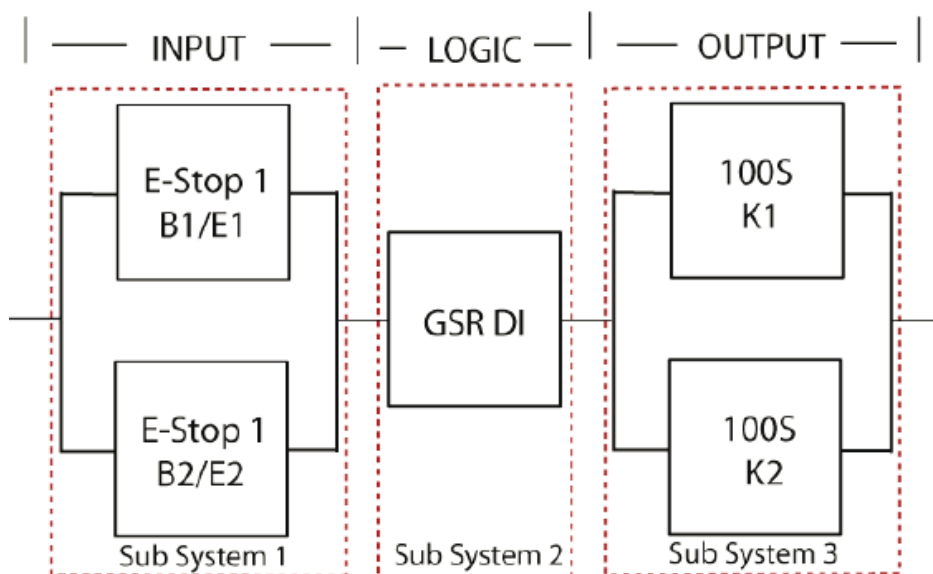

The functional safety ratings for the E-Stop INPUT subsystem are:

SB E-Stop	
PL	e
PFH [1/h]	2.47E-8
Cat.	4
MTTFd [a]	100 (High)
DCavg [%]	99 (High)
CCF	65 (fulfilled)

The functional safety ratings for the GSR SI LOGIC subsystem are:

SB Monitoring Safety Relay: GSR-SI	
PL	e
PFH [1/h]	3.98E-9
Cat.	4
MTTFd [a]	<i>not relevant</i>
DCavg [%]	<i>not relevant</i>
CCF	<i>not relevant</i>

Safety Function Documents: GSR

Two Hand Control Products:

800Z Zero Force Buttons / MSR125 Safety Relay / GSR SI Safety Relay

Safety Rating: PLd, Cat. 3 to EN ISO 13849.1 2008

The functional safety ratings for the 100S OUTPUT subsystem are:

SB Safety Contactors	
PL	e
PFH [1/h]	2.47E-8
Cat.	4
MTTFd [a]	100 (High)
DCavg [%]	99 (High)
CCF	65 (fulfilled)

Note that the 800Z palm buttons, E-Stop and Safety Contactors data includes MTTFd, DCavg, and CCF data. This is because these are electro-mechanical devices. Electro-mechanical devices functional safety evaluations include how frequently they are operated, whether they are effectively monitored for faults and properly specified and installed.

SISTEMA calculates the MTTFd using B10d data provided for the contactors along with the estimated frequency of use entered during the creation of the SISTEMA project. This application example presumes that the E-Stop is operated or tested once per day ie 365 times per year.

The DCavg (99%) for the contactors was selected from the Output Device table of EN ISO 13849-1 Annex E. "Direct Monitoring".

The DCavg (99%) for the E-Stop was selected from the Input Device table of EN ISO 13849-1 Annex E. "Cross Monitoring".

The (CCF) value is generated using the scoring process outlined in Annex F of ISO 13849-1.

The complete CCF scoring process must be done when actually implementing an application. A minimum score of 65 points must be achieved. A CCF of 65 was entered for practical purposes in each case for this application example.

Verification and Validation Plan

Verification and Validation play an important role in the avoidance of faults throughout the safety system design and development process. ISO/EN 13849-2 sets the requirements for verification and validation. It calls for a documented plan to confirm all the Safety Functional Requirements have been met.

Verification is an analysis of the resulting safety control system. The Performance Level (PL) of the safety control system is calculated to confirm it meets the Required Performance Level (PLr) specified. The SISTEMA software tool is typically utilized to perform the calculations and assist with satisfying the requirements of ISO 13849-1.

Validation is a functional test of the safety control system to demonstrate that it meets the specified requirements of the safety function. The safety control system is tested to confirm all of the safety related outputs respond appropriately to their corresponding safety related inputs.

The functional test should include normal operating conditions in addition to potential fault inject of failure modes. A checklist is typically used to document the validation of the safety control system.

Safety Function Documents: GSR

Two Hand Control Products:

800Z Zero Force Buttons / MSR125 Safety Relay / GSR SI Safety Relay

Safety Rating: PLd, Cat. 3 to EN ISO 13849.1 2008

Two Hand Control Station Safety function verification and validation checklist

GENERAL MACHINERY INFORMATION			
Machine Name / Model Number			
Machine Serial Number			
Customer Name			
Test Date			
Tester Name(s)			
Schematic Drawing Number			
Guardmaster Safety Relay Model			
Safety Wiring and Relay Configuration Verification			
Test Step	Verification	Pass/Fail	Changes/Modifications
	Visually inspect the safety relay circuit is wired as documented in the schematics.		
	Visually inspect the safety relay rotary switch settings are correct as documented.		
Normal Operation Verification - The safety relay system properly responds to all normal Start, Stop, Estop and Reset Commands			
Test Step	Verification	Pass/Fail	Changes/Modifications
	Initiate a Start Command by simultaneously pressing both palm buttons. Both contactors should energize for a normal machine run condition. Verify proper machine status indication and safety relay LED indication.		
	Initiate a Stop Command by simultaneously releasing both palm buttons. Both contactors should de-energize for a normal machine Stop condition. Verify proper machine status indication and safety relay LED indication.		
	While Stopped, only press the left palm button. The door should remain closed and locked. Both contactors should remain de-energized and open for a normal safe condition. Verify proper machine status indication and safety relay LED indication. Repeat for right palm button.		
	Initiate Reset Command. Both contactors should remain de-energized. Verify proper machine status indication and safety relay LED indication.		
Abnormal Operation Verification - The Safety Relay system properly responds to all foreseeable faults with corresponding diagnostics. Two Hand Run Station Input Tests			
Test Step	Validation	Pass/Fail	Changes/Modifications
	While Stopped, press the left palm button followed by the right 1 sec. later. Both contactors should remain de-energized and open. Verify proper machine status indication and safety relay LED indication. Repeat for sequence starting with the right palm button.		
	While Running, remove the Channel 1 wire from the E-Stop pushbutton. Both contactors should de-energize. Verify proper machine status indication and safety relay LED indication. Repeat for Channel 2.		
	While Running, short Channel 1 of the safety relay to +24VDC. Both contactors should de-energize. Verify proper machine status indication and safety relay LED indication. Repeat for Channel 2.		
	While Running, short Channel 1 of the safety relay to (-) 0VDC. Both contactors should de-energize. Verify proper machine status indication and safety relay LED indication. Repeat for Channel 2.		
	While Running, short Channels 1 & 2 of the safety relay. Both contactors should de-energize. Verify proper machine status indication and safety relay LED indication.		
GSR Logic Solver Tests			
Test Step	Validation	Pass/Fail	Changes/Modifications
	While Running, remove the single wire safety connection between two adjoining safety relays in the system. All contactors should de-energize. Verify proper machine status indication and safety relay LED indication. Repeat for all safety connections. This test is not applicable for single relay circuits.		
	While Running, turn the logic rotary switch on the safety relay. All contactors should remain de-energized. Verify proper machine status indication and safety relay LED indication. Repeat for all safety relays in the system.		
Safety Contactor Output Tests			
Test Step	Validation	Pass/Fail	Changes/Modifications
	While Running, remove the contactor feedback from the safety relay. All contactors should remain energized. Initiate a Stop Command followed by a Reset Command. The relay should not restart or reset. Verify proper machine status indication and safety relay LED indication.		

Safety Function Documents: GSR

Two Hand Control Products:

800Z Zero Force Buttons / MSR125 Safety Relay / GSR SI Safety Relay

Safety Rating: PLd, Cat. 3 to EN ISO 13849.1 2008

GSR Emergency Stop Safety Function Verification and Validation Checklist.

GENERAL MACHINERY INFORMATION			
Machine Name / Model Number			
Machine Serial Number			
Customer Name			
Test Date			
Tester Name(s)			
Schematic Drawing Number			
Guardmaster Safety Relay Model			
Safety Wiring and Relay Configuration Verification			
Test Step	Verification	Pass/Fail	Changes/Modifications
	Visually inspect the safety relay circuit is wired as documented in the schematics.		
	Visually inspect the safety relay rotary switch settings are correct as documented.		
Normal Operation Verification - The safety relay system properly responds to all normal Start, Stop, E-stop and Reset Commands			
Test Step	Verification	Pass/Fail	Changes/Modifications
	Initiate a Start Command. Both contactors should energize for a normal machine run condition. Verify proper machine status indication and safety relay LED indication.		
	Initiate a Stop Command. Both contactors should de-energize for a normal machine Stop condition. Verify proper machine status indication and safety relay LED indication.		
	While Running, press the E-Stop pushbutton. Both contactors should de-energize and open for a normal safe condition. Verify proper machine status indication and safety relay LED indication. Repeat for all E-Stop pushbuttons.		
	While Stopped, press the E-Stop pushbutton, initiate a Start Command. Both contactors should remain de-energized and open for a normal safe condition. Verify proper machine status indication and safety relay LED indication. Repeat for all E-Stop pushbuttons.		
	Initiate Reset Command. Both contactors should remain de-energized. Verify proper machine status indication and safety relay LED indication.		
Abnormal Operation Verification - The Safety Relay system properly responds to all foreseeable faults with corresponding diagnostics. E-Stop Input Tests			
Test Step	Validation	Pass/Fail	Changes/Modifications
	While Running, remove the Channel 1 wire from the safety relay. Both contactors should de-energize. Verify proper machine status indication and safety relay LED indication. Repeat for Channel 2.		
	While Running, short the Channel 1 of the safety relay to +24VDC. Both contactors should de-energize. Verify proper machine status indication and safety relay LED indication. Repeat for Channel 2.		
	While Running, short the Channel 1 of the safety relay to (-) 0VDC. Both contactors should de-energize. Verify proper machine status indication and safety relay LED indication. Repeat for Channel 2.		
	While Running, short Channels 1 & 2 of the safety relay. Both contactors should de-energize. Verify proper machine status indication and safety relay LED indication.		
GSR Logic Solver Tests			
Test Step	Validation	Pass/Fail	Changes/Modifications
	While Running, remove the single wire safety connection between two adjoining safety relays in the system. All contactors should de-energize. Verify proper machine status indication and safety relay LED indication. Repeat for all safety connections. This test is not applicable for single relay circuits.		
	While Running, turn the logic rotary switch on the safety relay. All contactors should remain de-energized. Verify proper machine status indication and safety relay LED indication. Repeat for all safety relays in the system.		
Safety Contactor Output Tests			
Test Step	Validation	Pass/Fail	Changes/Modifications
	While Running, remove the contactor feedback from the safety relay. All contactors should remain energized. Initiate a Stop Command followed by a Reset Command. The relay should not restart or reset. Verify proper machine status indication and safety relay LED indication.		

Safety Function Documents: GSR

Two Hand Control Products: 800Z Zero Force Buttons / MSR125 Safety Relay / GSR SI Safety Relay

Safety Rating: PLd, Cat. 3 to EN ISO 13849.1 2008

Additional Resources

For more information about the products used in this example refer to these resources.

Document	Pub. No.	Description
Guard Locking Switch Installation Instructions	440G-IN007	How to install, commission, operate and maintain the 440G-TZS21UPRH
Guardmaster Safety Relay Installation Instructions	10000175129	How to install, commission, operate and maintain the 440R-D22R2 Safety Relays
Guardmaster Safety Relay Troubleshooting Guide	440R-TG002	How to troubleshoot the 440RD22R2 Safety Relays
Guardmaster Expansion Relay Installation Instructions	440R-IN045	How to install, commission, operate and maintain the 440R-EM4R2D Expansion Relay
Guardmaster Expansion Relay Troubleshooting Guide	440R-TG001	How to install, commission, operate and maintain the 440R-EM4R2D Expansion Relay
Safety Products Catalog	S117-CA001A	Overview of Safety products, product specifications, and application examples
GuardShield Type 4 User Manual	440L-UM003	How to install, operate, and maintain the 440L Safety Light Curtains
Next Generation Guardmaster Safety Relays	SAFETY-WD001	Functional descriptions, guidance, and wiring for Safety Relays
Heavy Duty Guard Interlock Switch Installation Instructions	440K-IN008	How to install, configure, commission, operate, and maintain MT-GD2 Interlock Switches
Trojan T15 Interlock Switch Installation Instructions	440K-IN003	How to install, configure, commission, operate, and maintain Trojan T15 Interlock Switches
Safety Interlock Switches Brochure	EUSAFE-BR001	Overview of Interlock Switches
Guardmaster Safety Relay SI Installation Instructions	440R-IN042	How to install, configure, commission, operate, and maintain GSR SI Safety Relays
Guardmaster Safety Relays Selection Guide	440R-SG001	Overview of Guardmaster Safety Relays
RightSight Photoelectric Sensor Installation Instructions	42EF-IN003	How to install, commission, operate, and maintain 42EF Photoelectric Sensors
MSR42 Control Module User Manual	440R-UM008	How to install, commission, operate, and maintain MSR42 Systems
MSR45E Safety Relay Expansion Module User Manual	440R-UM007	How to install, commission, operate, and maintain the MSR45E Expansion Module
SensaGuard Integrated Latch Unique Coded Installation Instructions	440N-IN011	How to install, commission, operate, and maintain the SensaGuard
Touch Button and Guard Installation Instructions	800Z-IN001-MU	How to install and mount the 800Z Touch Button
Zero-Force Touch Buttons Family Brochure	800Z-BR002	Brochure that describes all 800Z Palm Buttons
MSR12T Safety Relays Installation Instructions	MINOTR-IN010	How to install, configure, commission, operate, and maintain the MSR 12T Safety Relays
Guardmaster Safety Relay Installation Instructions	440R-IN042	How to install, commission, operate and maintain the 440R-S12R2 Safety Relays

Safety Function Document

Disclaimer

The information contained in this and any related publications is intended as a guide only. Every care has been taken to ensure that the information given is accurate at time of publication.

Neither NHP nor any of the manufacturers portrayed in this and any related publications accept responsibility for any errors or omissions contained therein nor any misapplications resulting from such errors or omissions.

Risk assessments should be conducted by authorized persons. The purchaser and installer are responsible for ensuring the safety system(s) incorporating these products complies with all current regulations and applicable standards.

Products are subject to change without notice and may differ from any illustration(s) provided. All products offered for sale are subject to NHP standard Conditions of Sale, a copy of which is available on application.