

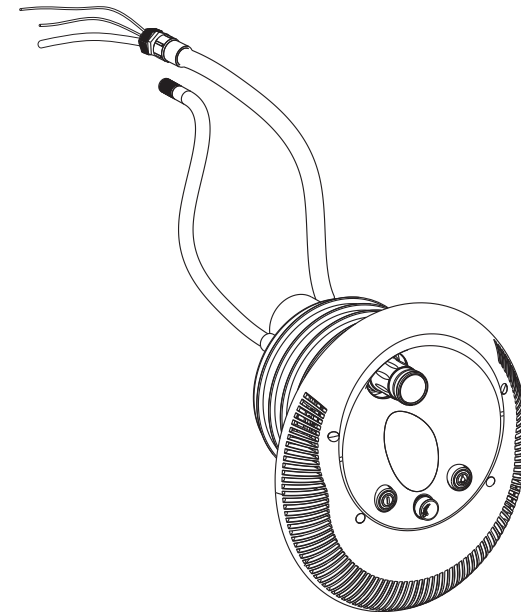

**Product Name: COUNTER CURRENT JET**

**Product Model No.:EM0055**



Please read this manual carefully before using the product  
please keep this manual for future reference

## INDEX

1. Safety precautions .....	3
2. Specifications .....	4
3. Product structure and name of components .....	4-6
4. Installation instructions .....	7-14
5. Operating instructions .....	15
6. Maintenance and warrenty .....	15
7. Control box instructions .....	16-19

## PART LIST

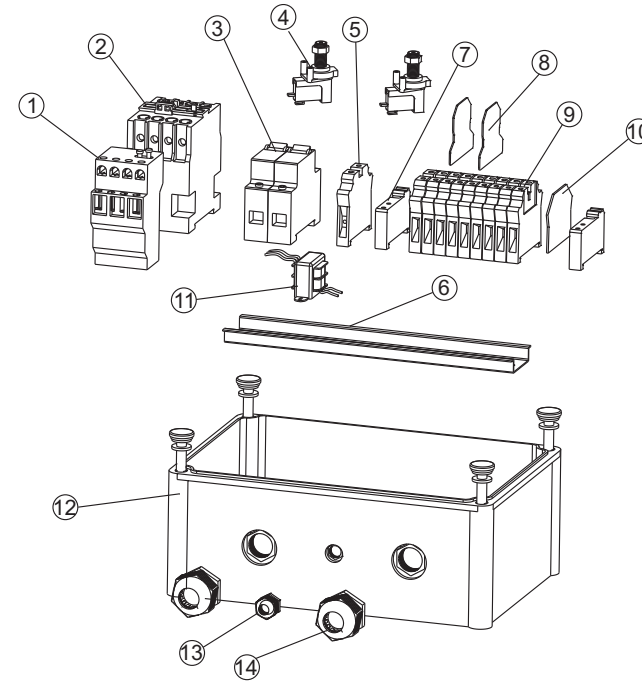

Item No.	Part No.	Product Description	QTY
1	04014099	thermal overload relay	1
2	04014100	AC contactor	1
3	04014101	breaker	2
4	04014103	pneumatic switch	2
5	04014102	earth terminal	1
6	04014019	track	1
7	04014104	terminal fixing parts	2
8	04014107	clapboard	3
9	04014108	wiring terminal	2
10	04014105	head board	2
11	04014109	transformer	1
12	04014110	control box	1
13	04014013	cable gland	1
14	04014085	cable gland	2

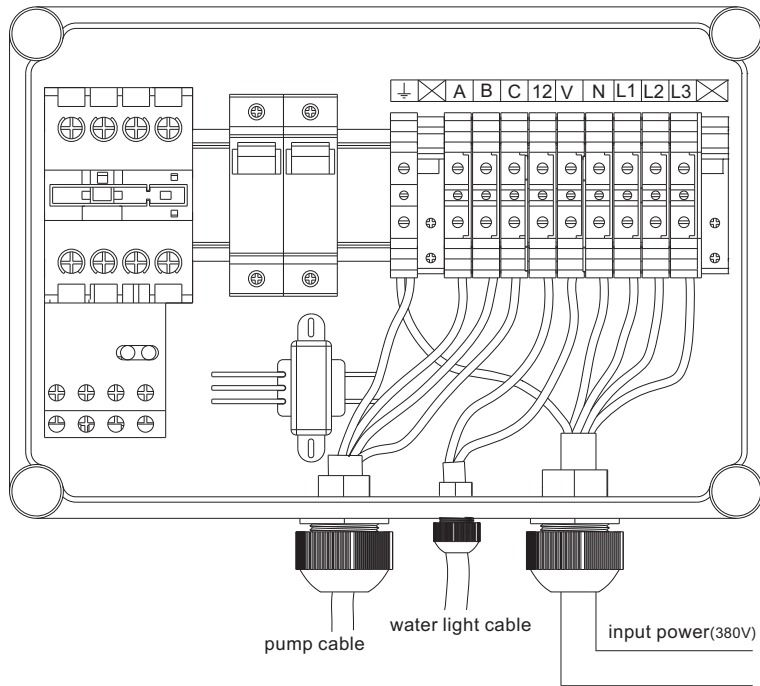

380V control box wiring diagram

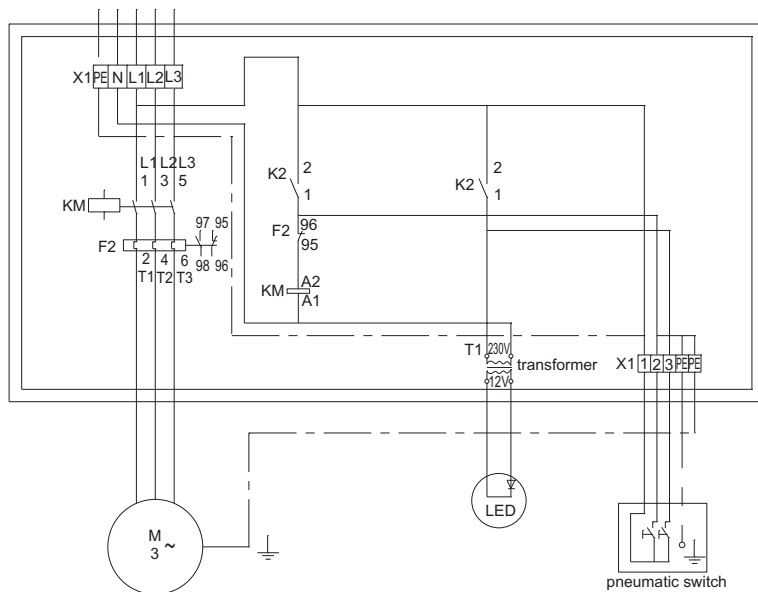

380V/50Hz counter current jet circuit diagram

## 1. safety precautions:

- 1). Important note: the basic requirements of installation, usage and maintenance process of users are included in the safety operating instructions.
- 2). Please follow safety instructions carefully. Failure to adhere to safety instructions could lead to personal injury.

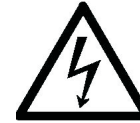

Please pay special attention to wiring of 3 phase motors to ensure shaft rotation is in the direction of arrow.

- 3). Installation must be carried out by qualified persons. Electrical work must be carried out by a qualified electrician.
- 4). Emaux Water Technology is not liable for any damages personal or property if equipment is installed by unauthorized persons or not in line with installation and safety instructions provided.
- 5). Please read instructions and operating instructions thoroughly.
- 6). Please ensure pool water is balanced at all times. Operating equipment above the maximum water temperature will lead to damages.
- 7). The safety instructions for repair and maintenance, inspection and the operation engineering must ensure that the performance of repair and maintenance, checking and installation are approved by qualified technician to work. Staff responsible for the work need read the manual thoroughly. The industrial accident prevention rules must be obeyed. All the work relating to pump only can be done when it is stopped. The procedures mentioned in the operating instructions of the pump must be obeyed. The products harmful to health carried by the pump or counter current jet must be purified.
- 8). If the box has been opened, please check all components are supplied.
- 9). counter current jet is a countercurrent facility using in any swimming pools.

## 2. Specifications

### 1 ) Pump model parameters

Model	Qmax		Hmax (m)	V/Hz	Power	
	m <sup>3</sup> /h	l/min			KW	HP
AFS40	75	1300	13	380/50	3.0	4.0
AFS55	90	1500	17.5		4.0	5.5
SR30	35	600	20	220/50	2.18	3
SR30X2	70	1200	25		4.36	6

## 3. Product description and parts breakdown

### 1 ) counter current jet parts list

Key No.	Part No.	Product Description	Qty
1	89090104	Air switch for water pump	1
2	89090105	Air adjusting	1
3	89090106	Air switch for water light	1
4	89090107	Threaded plug for lid	1
5	03011345	M5*20mm screws	4
6	89090108	Lid	1
7	88041939	LED-P10 light(Auto change colour)	1
	88041940	LED-P10 light(White colour)	1
8	89090110	Support frame	1
9	89090111	Water jet	1
10	01093016	D12mmXd8mmX40mm air adjusting hose	2
11	01093015	D5mmXd3mmX3M transparent hose	2
12	03011320	M6X20mm screws	4
13	89090112	Water jet fixed pipe	1
14	89090113	Vinyl pool fittings	1
15	89090114	Counter Current Jet body	1
16	89090115	Conduit for light cable and air hose	1
17	89090116	Cable grand	1
18	01151380	Exhaust hose	1
19	89090117	Venting plug	1

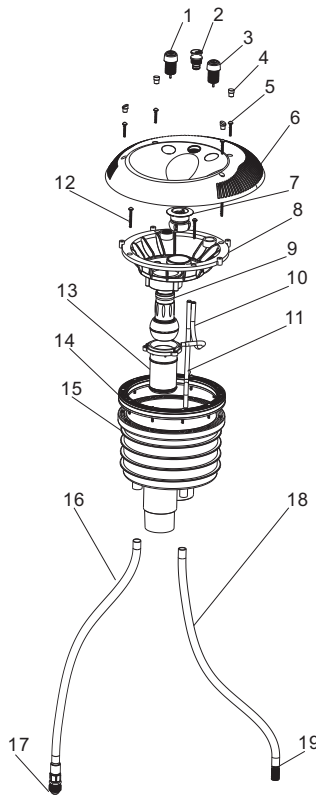

## CONTROL BOX WIRING DIAGRAM & CIRCUIT DIAGRAM

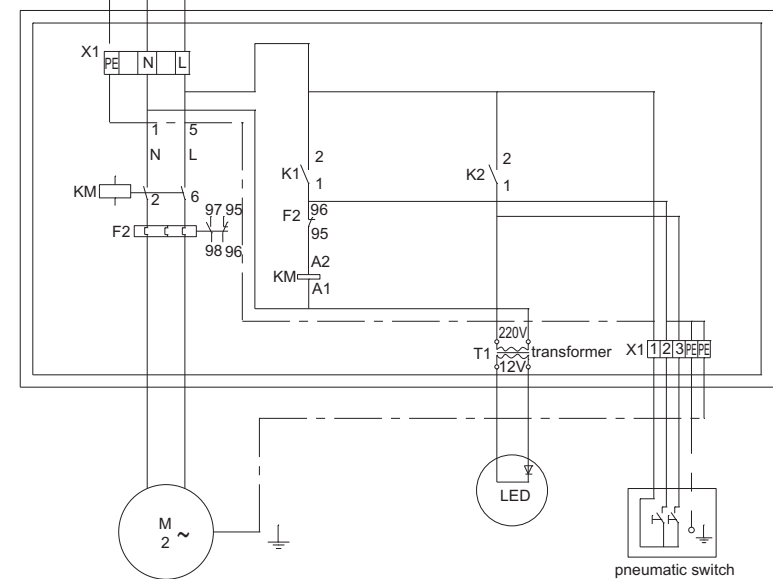
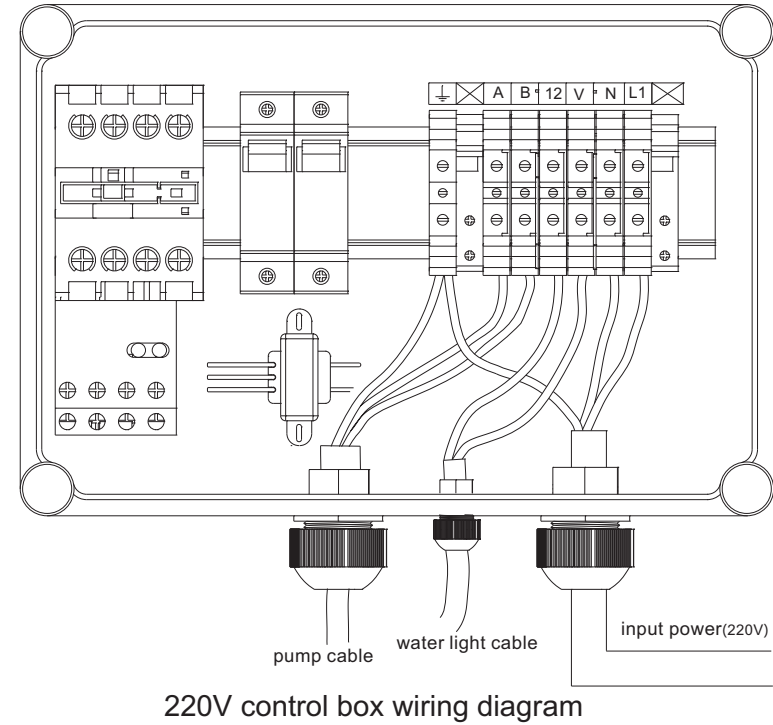

## COUNTER CURRENT JET CONTROL BOX

Model: SWJ-CB(220V/380V)

Code: 08080020/08080021

**APPLICABLE FOR BETWEEN EMAUX COUNTER CURRENT JET AND PUMP CONTROL.**

### Warning:

This electrical control box must be installed by a licensed or certified electrician or a qualified serviceman in accordance to the requirements of your government standard or local authorities. Improper installation will create electric hazards which could result in serious injury, death as well as damage to the property.



**CUT THE POWER BEFORE SERVICE AND MAINTAINANCE!**

### INSTALLATION EXPLAIN

1. The control box must be installed in a dry place.
2. After the control box is fixed . According to the wiring diagram, the pump and the water light power cord access control box.
3. Connect the two transparent air pipes to the corresponding pneumatic switches.

### SPECIFICATIONS

Input voltage	220V/380V
Water light output voltage	AC 12V
Pump output voltage	220V/380V
Water light power	1W
Pump power	4KW

## 2) AFS40/55 parts list

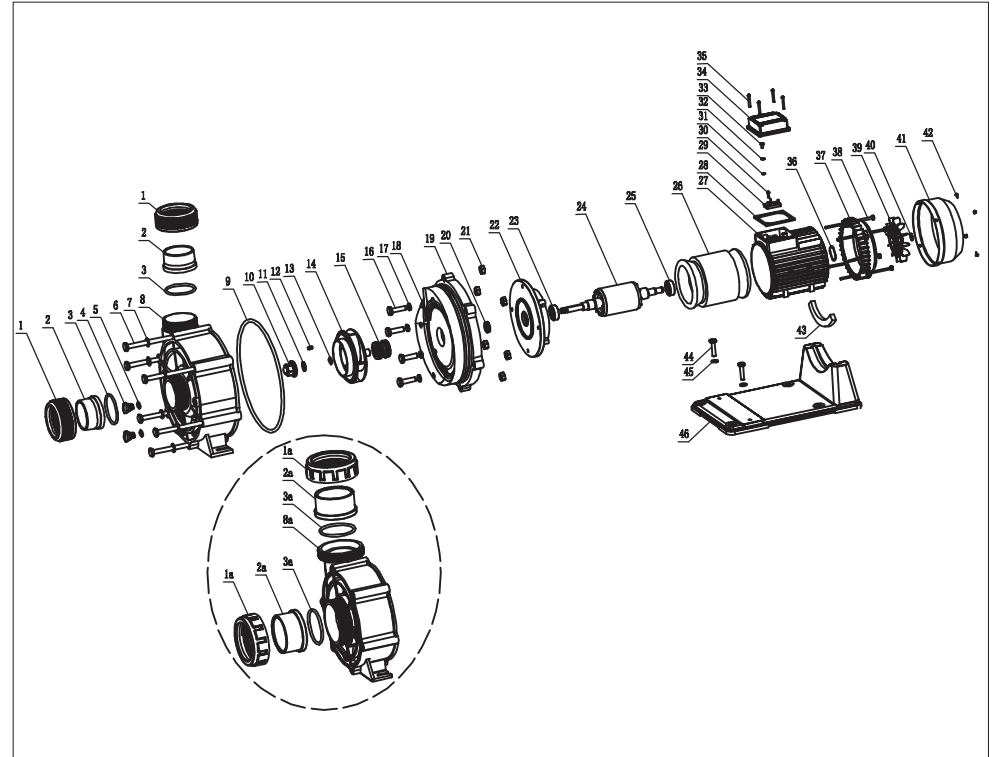

NO.	Component	Specification	Material	QTY	NO.	Component	Specification	Material	QTY
1	Tie-in Nut	G2½	ABS	2	22	Front cover		ADC12	1
1a	Tie-in Nut	3"	ABS	2	23	Bearing	6205		1
2	Tie-in	Ø60.3 Ø63	PVC	2	24	Rotor			1
2a	Tie-in	Ø75 Ø90	PVC	2	25	Bearing	6203		1
3	O-Ring	d62×4.5	NBR	2	26	Stator			1
3a	O-Ring	d93.6×5.7	NBR	2	27	Motor House		ADC12	1
4	Drainage Plug		PA66-GF	2	28	Terminal Box Pad		NBR	1
5	O-Ring	d11.2×2.4	NBR	2	29	Connection Pole		Melamine+Plating Zinc	1
6	Screw	M10×130	SUS304	6	30	Screw	M4×12	Plating Zinc	1
7	Pad		SUS304	6	31	Spring washer	Ø5	SUS304	2
8	Pump Casing	G2½	PP-GF	1	32	Pad	Ø5	SUS304	2
8a	Pump Casing	4½FBT	PP-GF	1	33	Screw	M4×12	SUS304	2
9	O-Ring	d208×6	NBR	1	34	Terminal Box		Flame Resistant ABS	1
10	Impeller Nut		PA6-GF	1	35	Screw	M4×30	SUS304	4
11	Light Spring Washer	d12	SUS304	1	36	Wave Spring Washer	D40	65Mn	1
12	Flat Key	4×12	SUS304	1	37	Back Motor Cover		ADC12	1
13	O-Ring	d25.2×2.4	NBR	1	38	Hexagon Screw	M5×190	SUS304	4
14	Impeller		PA66-GF	1	39	Fan		PP	1
15	Mechanical Seal	SB-20	Carbon/Ceramic/NBR	1	40	Shaft spring pad	d14		1
16	Screw	M8×35	SUS304	4	41	Fan Cover		ABS+PC	1
17	Pad		PA6	4	42	Belt pad screws		SUS304	4
18	O-Ring	d6×2	NBR	4	43	Rubber Strap		NBR	1
19	Pump Cover		PP-GF	1	44	Hexagon Screw	M8×16	SUS304	2
20	Shaft Washer	d20	NBR	1	45	Pad	Ø8	SUS304	2
21	Nut	M10	SUS304	6	46	Bracket		PP-GF	1

## Pump parts for SR

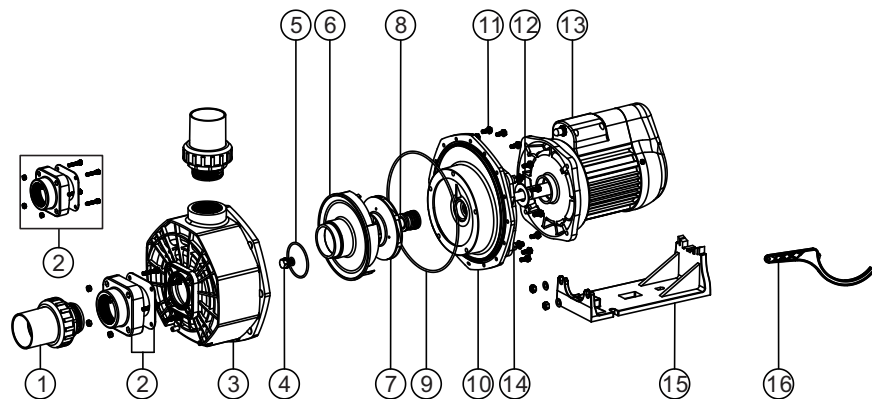

Key No.	Part No.	Product Description	Qty
1	89280306	2.0" Union	2
2	89023601	Connecting	1
3	89021308	SR Pump body	1
4	89021309	Screw for impeller with O-ring	1
5	02011108	O-Ring for diffuser	1
6	01111015	Diffuser	1
7	01311006	Impeller SR300(220V/50HZ)	1
8	04015001	3/4"Mechanical seal	1
9	02011093	O-Ring for flange	1
10	01021013	SR Pump Flange	1
11	03011080	M6×15 Hexagonal screw	16
12	02011101	Motor Slinger for	1
13	89021304	Motor SR300(220V/50HZ)	1
14	89021310	M8×20 Screw for motor with washer	4
15	01111031	Base with nut & washer for	1
16	01021021	Opening key	1

## 5. Operating Instructions

- 1).the water in the swimming pool is sucked from the side of the nozzle mask to the water pump, and then expelled through the nozzle.
- 2). the on/off switch of the water pump and the water lamp are installed on the cover of the nozzle. It can be operated only by hand press.
- 3).the direction of the water output can be adjusted by moving the nozzle up and down, left and right, while rotating the nozzle can adjust the amount of the water output.
- 4). if air is needed to be injected into the water, the adjustable valve on the mask surface can be regulated. (Note: keeping rotating counter-clockwise can twist off the valve)
- 5).since during testing three-phase alternating current is used, the correct rotating direction of the arrow shown on the fan cover of the engine must be found to indicate the correct rotating direction of the motor of the water pump.

## 6. maintenance and warrenty

- 1). clean the nozzle, the pump and the surface of the control box regularly; check the water pump and the area where plastic nozzle ring is sealed regularly. Change if needed.
- 2).keep the motor clean, to ensure ventilation position ( fan cover ) does not have any obstacles.
- 3). when uninstalling the pump, the pump switch must be closed and all power must be disconnected. The replacement must be performed by a professional officer. Please refer to the user manual for the Isolation of screw nuts of the inlet and outlet pipe connected to the pump, replacement of mechanical seals and the order of assembly installation.
- 4). when maintenance / repair in the freezing winter, it is necessary to lower the water level which is lower than that of the nozzle shell. flow out all of the water in both the inlet and outlet water pipes.
- 5).when the control box is out of order, it must be maintained by qualified electricians or qualified maintainance staff. for details please refer to the control box user manual.

No.	Specification
1	PVC PIPE 2"*70mm
2	2" PIPE ELBOW(45°)
3	PVC PIPE 2"*70mm
4	2"Union Ball Valve
5	PVC PIPE 2"*100mm
6	REDUCING PIPE 2.5"*2"
7	PVC PIPE 2.5"*105mm
8	2.5" PIPE ELBOW(45°)
9	REDUCING PIPE 2.5"*2"
10	PVC PIPE 2"*170mm
11	2"Union Ball Valve
12	PVC PIPE 2"*220mm
13	2" PIPE ELBOW(90°)
14	PVC PIPE 2"*170mm

remarks: Please take reference from the above piping sequence

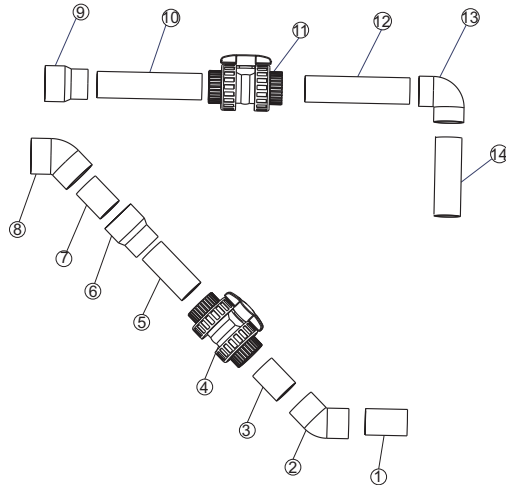

Figure15  
(only for SR30 water pump)

No.	Specification
1	2.5" PIPE TEE
2	PVC PIPE 2.5"*105mm
3	PVC PIPE 2.5"*105mm
4	2.5" PIPE ELBOW(90°)
5	2.5" PIPE ELBOW(90°)
6	PVC PIPE 2.5"*105mm
7	PVC PIPE 2.5"*105mm
8	REDUCING PIPE 2.5"*2"
9	REDUCING PIPE 2.5"*2"
10	PVC PIPE 2"*95mm
11	PVC PIPE 2"*95mm
12	2" PIPE ELBOW(90°)
13	2" PIPE ELBOW(90°)
14	PVC PIPE 2"*125mm
15	PVC PIPE 2"*125mm
16	2"Union Ball Valve
17	2"Union Ball Valve
18	PVC PIPE 2"*70mm
19	PVC PIPE 2"*70mm
20	2.5" PIPE TEE
21	PVC PIPE 2.5"*105mm
22	PVC PIPE 2.5"*105mm
23	2.5" PIPE ELBOW(90°)
24	2.5" PIPE ELBOW(90°)
25	PVC PIPE 2.5"*105mm
26	PVC PIPE 2.5"*105mm
27	REDUCING PIPE 2.5"*2"
28	REDUCING PIPE 2.5"*2"
29	PVC PIPE 2"*95mm
30	PVC PIPE 2"*95mm
31	2"Union Ball Valve
32	2"Union Ball Valve
33	PVC PIPE 2"*70mm
34	PVC PIPE 2"*70mm
35	2" PIPE ELBOW(90°)
36	2" PIPE ELBOW(90°)
37	PVC PIPE 2"*150mm
38	PVC PIPE 2"*150mm

remarks: Please take reference from the above piping sequence

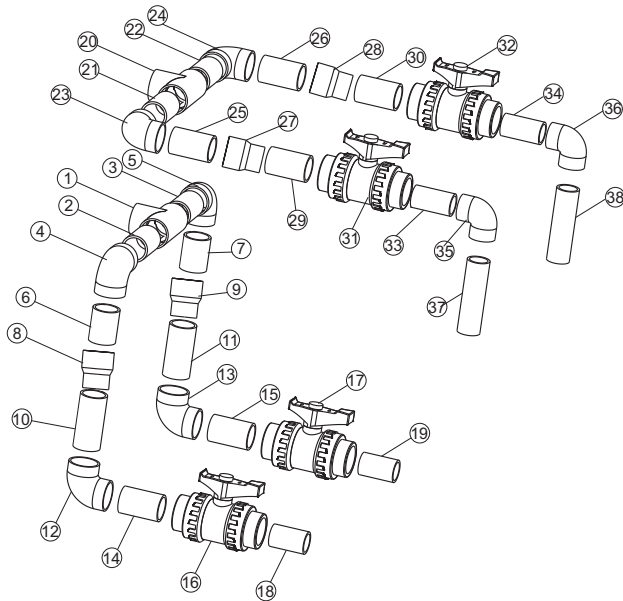

Figure16  
(only for 2XSR30 water pump)

#### 4. Installation instructions

I. the counter current jet can be used in Concrete, composite fiberglass and vinyl pools. The installation is as follow:

1) Concrete pool installation:

- a) Use 4 screws(M6\*20) to fix the counter current jet plate to the pool wall hole. ( Figure 1)
- b) Fit counter current jet body into in to concrete wall. ( Figure 2)

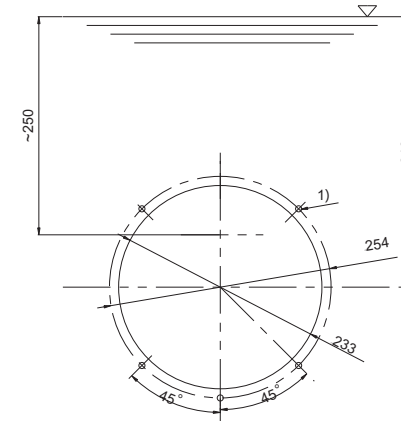

Figure 1

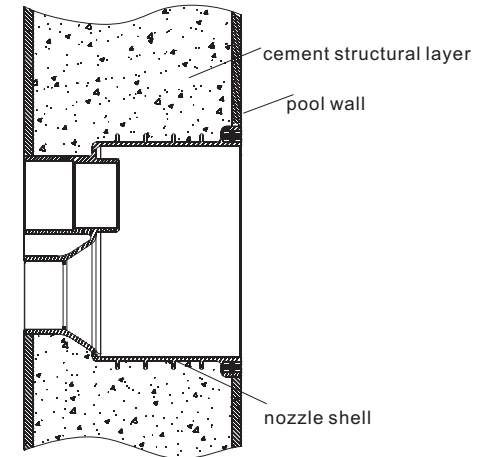

Figure 2

## 2) Composite Fibreglass pool installation:

- a) Using the template drill 14 holes into the fibreglass pool shell. ( Figure 3)
- b) Install the outer shell, plastic ring, in the correct order on the pool shell wall. ( Figure 4)
- c) Mount the counter current jet faceplate onto the fiber pool using 10 piece of M6 screws. (Hole 1 in Figure 3)

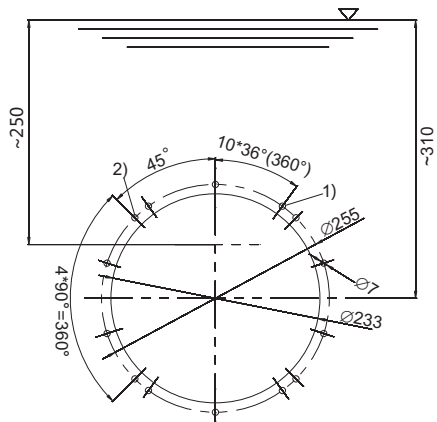

Figure 3

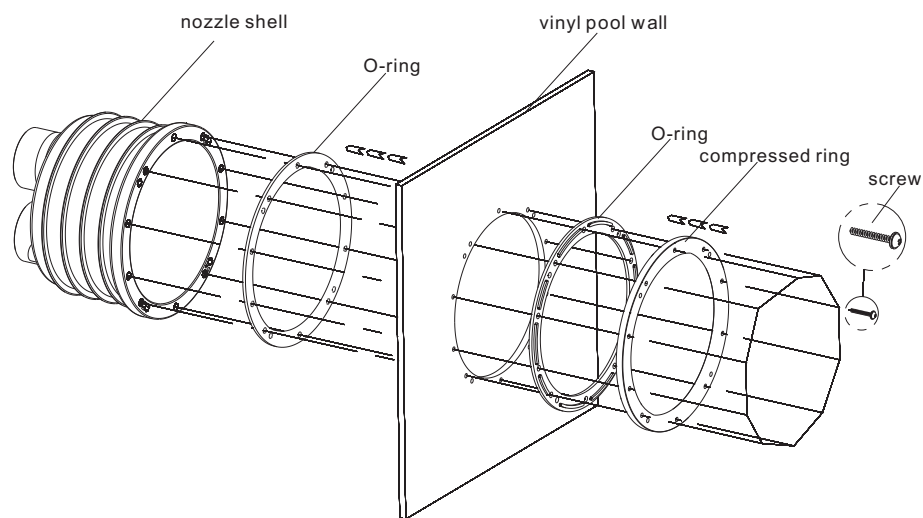

Figure 4

## III . Installation of counter current jet

- 1) please refer to figure 13 for the whole installation.
- 2) for each model of pump pipe please refer to figure 14, 15, 16.
- 3) pumps and contror box must be installed in dry areas. It is absolutely necessary to expel water at the bottom part.
- 4) in order to ensure normal operation of air switch, the distance between the swimming pool and the controller box must not be more than 3 meters.
- 5) the air pipe must be installed in the protective pipe. It can be replaced if necessary.
- 6) the installation of electric connections must be performed by a qualified electrician.

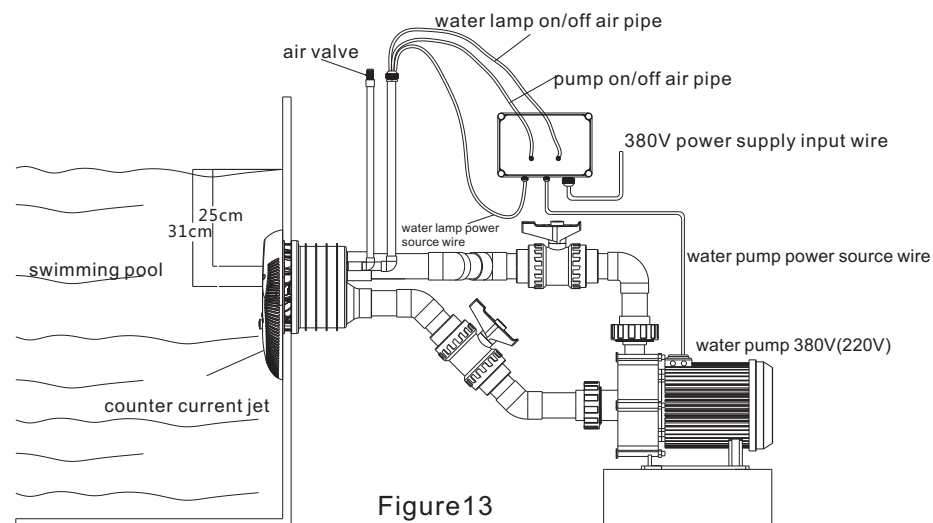

Figure13

No.	Specification
1	PVC PIPE 2.5**175mm
2	2.5" PIPE ELBOW(45°)
3	PVC PIPE 2.5**105mm
4	2.5"Union Ball Valve
5	PVC PIPE 2.5**105mm
6	2.5" PIPE ELBOW(45°)
7	2.5" PIPE ELBOW(45°)
8	PVC PIPE 2.5**120mm
9	2.5" PIPE ELBOW(45°)
10	PVC PIPE 2.5**105mm
11	2.5"Union Ball Valve
12	PVC PIPE 2.5**105mm
13	2.5" PIPE ELBOW(90°)
14	PVC PIPE 2.5**175mm

remarks: Please take reference from the above piping sequence

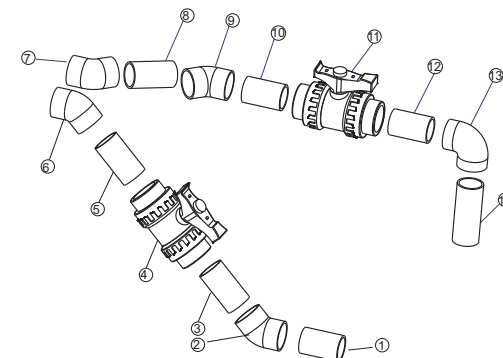

Figure14  
(only for AFS40/50 water pump)



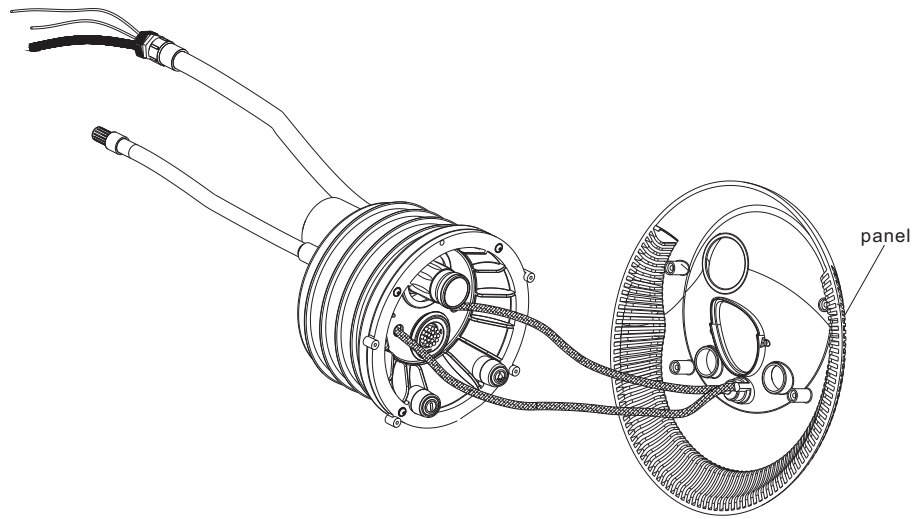

Figure 11

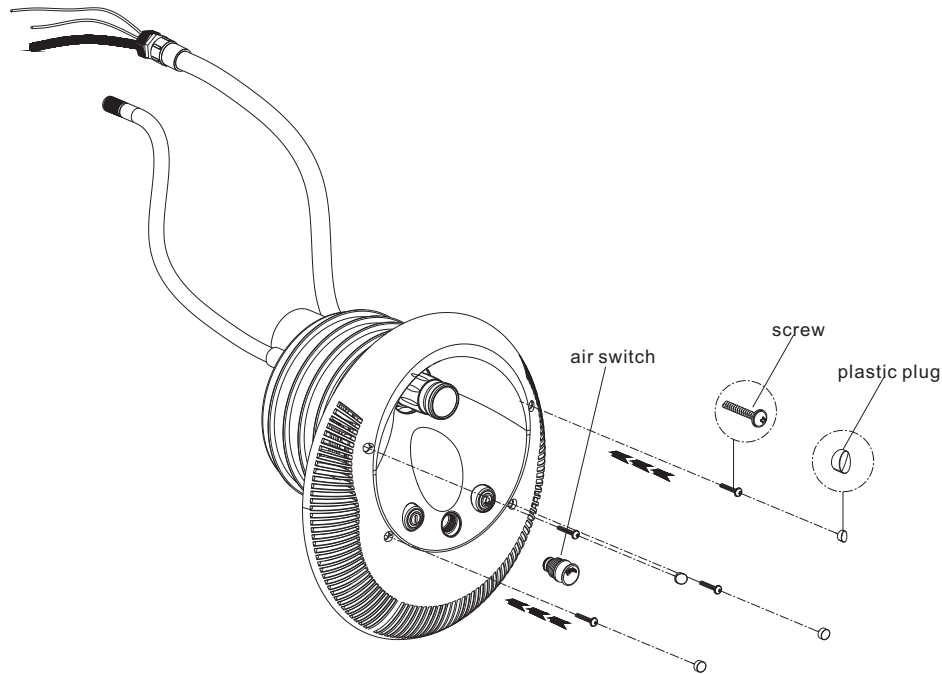

Figure 12

3 ) to install a counter current jet shell onto a vinyl pool:

- a ) for vinyl pool, according to the 16 holes on the counter current jet shell, first drill holes on the structural wall accordingly. ( Figure 5)
- b ) install the plastic ring and the outer shell with 2 M6\*20 screws ( hole 3 of Figure 5 ), and then install the plastic ring and ring for installing on the fiber pool using 10 M6\*45 screws .( Figure 6)

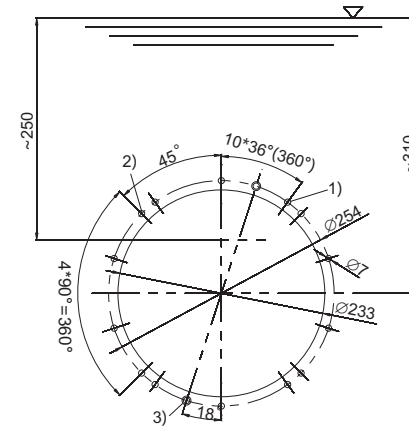

Figure 5

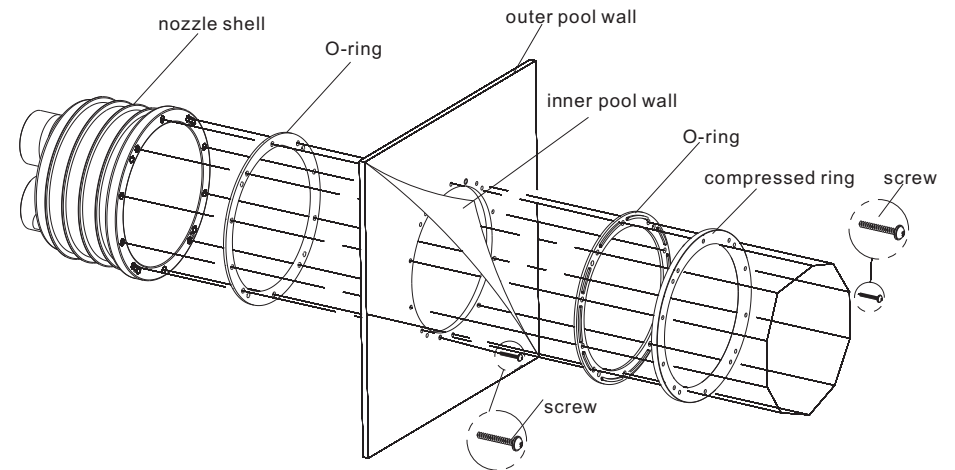

Figure 6

- 4) The structure of cement bag from inside of the pool and the outercasing installation methods of counter current jet:
- Embedded the counter current jet outer casing inside the cement wall and the surface of the outer case should be completed with the cement surface. (figure 8)
  - Opened the corresponding holes from inside of the cement bag and the holes should be completed with the fiber pool (figure 3).
  - Used 10 screws of M6X30 and fixed the rubber ring into the mounting ring. (figure 8)

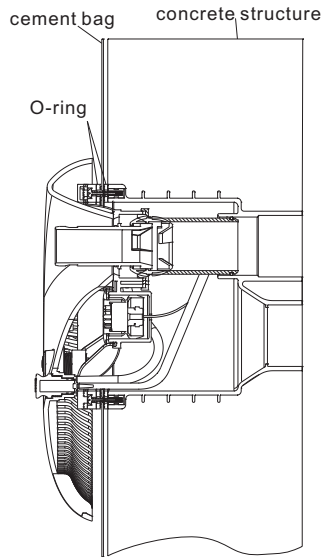

Figure 7

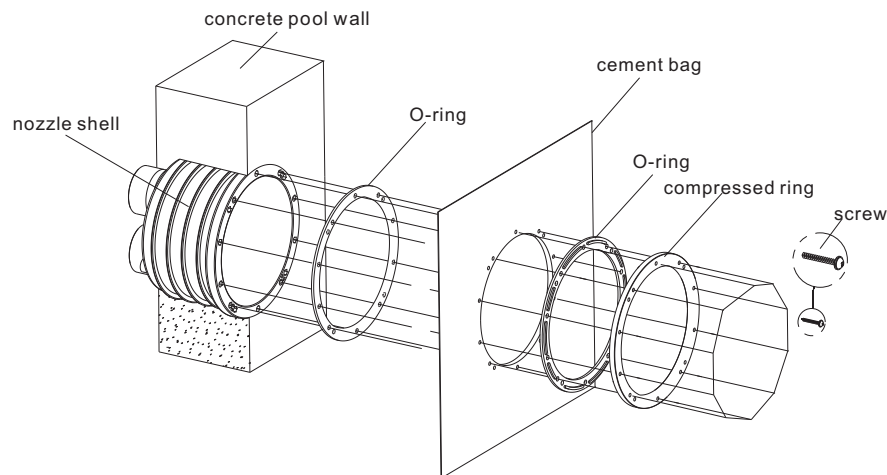

Figure 8

II. to install counter current jet outer shell

- 1) first use  $\phi 5$  transparent air tube and LED light cable respectively to pass through the connecting tube, then connect the two air pipes to the pump switch and pool light air switch respectively. ( Figure 9)
- 2) pass through the two pipes respectively from the hole of the support frame; and then use 4 M6 screws to fix the support frame onto the shell. ( Figure 10)
- 3) connect the pipes of the shell to the side of the mask of the air button. Connect the gas nozzle of the support frame to the middle of the gas nozzle (Figure 11); (Note: must not be reversed)
- 4) install the outer shell onto the support frame, fixed with 4 M5 screws, and then cork the screw hole using plastic cork. ( Figure 12)

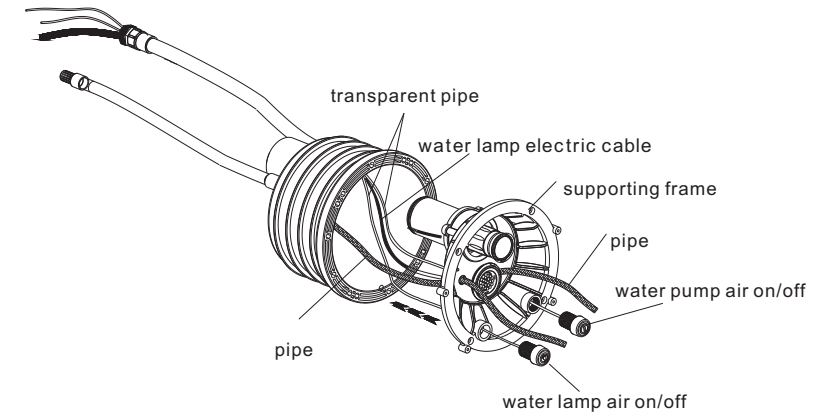

Figure 9

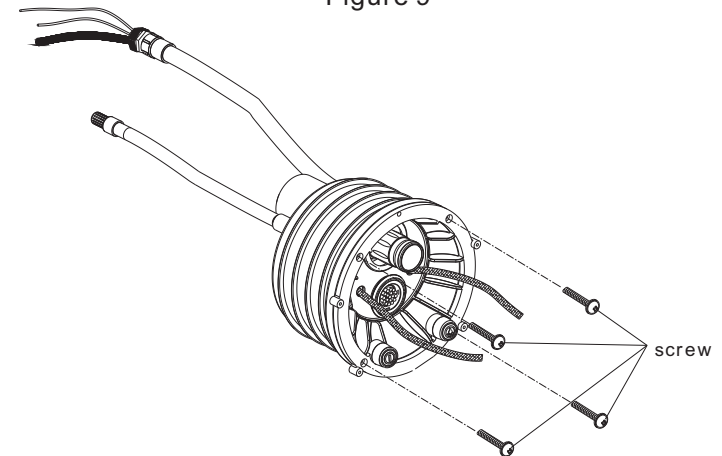

Figure 10