

USER MANUAL

MODEL 1010B Miniature, High Speed Short Range Modem with Transformer Isolation



PATTON
Electronics Co.



*An ISO-9001
Certified Company*

Part# 07M1010B-C
Doc# 039041UC
Revised 03/13/00

SALES OFFICE
(301) 975-1000
TECHNICAL SUPPORT
(301) 975-1007
<http://www.patton.com>

1.0 WARRANTY INFORMATION

Patton Electronics warrants all Model 1010B components to be free from defects, and will—at our option—repair or replace the product should it fail within one year from the first date of shipment.

This warranty is limited to defects in workmanship or materials, and does not cover customer damage, abuse or unauthorized modification. If this product fails or does not perform as warranted, your sole recourse shall be repair or replacement as described above. Under no condition shall **Patton Electronics** be liable for any damages incurred by the use of this product. These damages include, but are not limited to, the following: lost profits, lost savings, and incidental or consequential damages arising from the use of or inability to use this product. **Patton Electronics** specifically disclaims all other warranties, expressed or implied, and the installation or use of this product shall be deemed an acceptance of these terms by the user.

1.1 RADIO AND TV INTERFERENCE

The Model 1010B generates and uses radio frequency energy, and if not installed and used properly—that is, in strict accordance with the manufacturer's instructions—may cause interference to radio and television reception. The Model 1010B has been tested and found to comply with the limits for a Class A computing device in accordance with the specifications in Subpart J of Part 15 of FCC rules, which are designed to provide reasonable protection from such interference in a commercial installation. However, there is no guarantee that interference will not occur in a particular installation. If the Model 1010B does cause interference to radio or television reception, which can be determined by disconnecting the RS-232 interface, the user is encouraged to try to correct the interference by one or more of the following measures: moving the computing equipment away from the receiver, re-orienting the receiving antenna, and/or plugging the receiving equipment into a different AC outlet (such that the computing equipment and receiver are on different branches).

1.2 CE NOTICE

The CE symbol on your Patton Electronics equipment indicates that it is in compliance with the Electromagnetic Compatibility (EMC) directive and the Low Voltage Directive (LVD) of the Union European (EU). A Certificate of Compliance is available by contacting Technical Support.

1.3 SERVICE

All warranty and nonwarranty repairs must be returned freight prepaid and insured to Patton Electronics. All returns must have a Return Materials Authorization number on the outside of the shipping container. This number may be obtained from Patton Electronics Technical Services at:

telephone: **(301) 975-1007**
email: **support@patton.com**
web address: **http://www.patton.com**

NOTE: Packages received without an RMA number will not be accepted.

Patton Electronics' technical staff is also available to answer any questions that might arise concerning the installation or use of your Patton Model 1010B. Technical Service hours: **8AM to 5PM EST, Monday through Friday.**

2.0 GENERAL INFORMATION

Thank you for your purchase of this Patton Electronics product. This product has been thoroughly inspected and tested and is warranted for One Year parts and labor. If any questions arise during installation or use of the unit, contact Patton Electronics Technical Support (301) 975-1000.

2.1 FEATURES

- Transformer coupled for DC isolation between modems
- Immune to ground loops caused by ground potential differences
- Distances to 9.5 miles over 2 twisted pair (19 AWG @ 1200 bps)
- Supports data rates from 300 bps to 115.2 kbps
- Loops back all handshaking signals on the RS-232 interface
- Externally accessible DCE/DTE switch makes configuration easy
- Very thin case (.75") for closely spaced computer ports
- No AC power or batteries required—draws all necessary operating power from the RS-232 interface
- Provides surge protection of 600 Watts per wire

2.2 DESCRIPTION

The Patton Model 1010B miniature, high speed, transformer isolated short range modem lets two asynchronous RS-232 devices communicate between buildings, over two twisted pair. Supporting asynchronous data rates to 115.2 kbps, the Model 1010B derives the necessary power for operation from the data and control voltages on the RS-232 interface. DC transformer isolation on the line side gives the Model 1010B immunity to ground loops that would otherwise hamper between-building communications.

An external DCE/DTE switch lets you connect to the serial port of either a computer/terminal (DTE) or a modem (DCE) without using a crossover cable. The Model 1010B is available with three 4 wire interface options: RJ-11, RJ-45 or terminal blocks with strain relief.

3.0 CONFIGURATION

The Model 1010B also incorporates high speed avalanche diodes that intercept data line transient surges and shunt them safely to chassis ground. With surge handling capacity of 600W per wire at 1mS, the 1010B can protect itself and connected equipment from nearby lightning strikes and other surges of electromagnetic radiation.

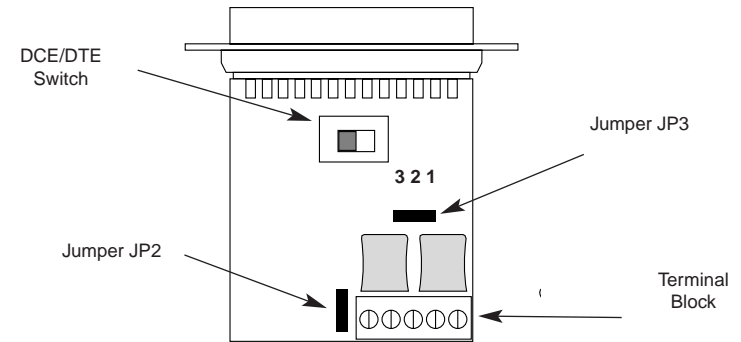

Figure 1. PC Board Showing Location of Jumpers and DTE Switch.

The Model 1010B is configured using an external DCE/DTE switch and two internal jumpers (the factory jumper settings are appropriate for most applications). This section describes the configuration switch and jumpers and shows factory defaults. Figure 1 below shows the location of the switch/jumpers on the Model 1010B's internal PC board.

3.1 SETTING THE DTE/DCE SWITCH

For your convenience, the Model 1010B has an externally accessible DCE/DTE switch (see Figure 2, below). If the device connected to the Model 1010B is a modem or multiplexer (or is wired like one), set the switch to "DTE." This setting causes the Model 1010B to behave like Data Terminal Equipment and transmit data on pin 2.

If the device connected to the Model 1010B is a PC, terminal or host computer (or is wired like one), set the switch to "DCE." This setting causes the Model 1010B to behave like Data Communications Equipment and transmit data on pin 3.

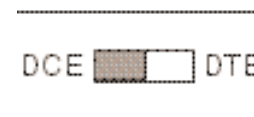

Figure 2. Model 1010B Close-up View of External DCE/DTE Switch

4.0 INSTALLATION

3.2 “NORMAL” vs. “MODEL 1010 COMPATIBLE” OPERATION

The table below shows jumper settings, including factory defaults.

Important: When using the Patton Model 1010B with an older Patton Model 1010, you must set the jumpers for Model 1010 compatible operation.

JUMPER SUMMARY TABLE #1			
Jumper	Function	“Normal”	“1010 Compatible”
JP2	Mode Select	Jumper OFF (default)	Jumper ON
JP3	Mode Select	Position 2&3 (default)	Position 1&2

Jumper JP2

Jumper JP2 is set in conjunction with jumper JP3 to place the Model 1010B in either “Normal” or “Model 1010 compatible” operating mode. For the Normal (factory default) setting, jumper JP2 should be placed on **only one** of the two pins. This is defined as “jumper OFF.” For the 1010 compatible setting, jumper JP2 should be placed on **both** of the pins. This is defined as “jumper ON.”

Jumper JP3

Jumper JP3 is set in conjunction with jumper JP2 to place the Model 1010B in either Normal or Model 1010 compatible operating mode. For the Normal (factory default) setting, jumper JP3 should be placed on **pins 2 and 3** (see Figure 3, below). For the Model 1010 compatible setting, jumper JP3 should be placed on **pins 1 and 2**. “Jumper OFF” is not a valid option.

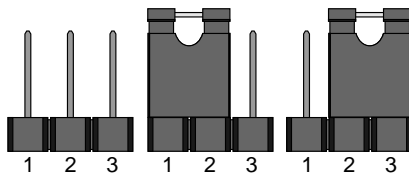

Figure 3. Jumper JP3 Orientation Showing the Two Valid Settings.

Once you have properly configured the DTE/DCE switch, you are ready to connect the Model 1010B to your system. This section tells you how to properly connect the Model 1010B to the twisted pair and RS-232 interfaces, and how to operate the Model 1010B.

4.1 CONNECTION TO THE TWISTED PAIR INTERFACE

The Model 1010B supports data-only communication between two RS-232 devices at distances to 8.5 miles and data rates to 115.2 kbps. There are two essential requirements for installing the Model 1010B:

1. These units work in **pairs**. Therefore, you must have one Model 1010B at each end of a two twisted pair interface.
2. To function properly, the Model 1010B needs two twisted pairs of metallic wire. These pairs must be **unconditioned**, dry metallic wire, between 19 and 26 AWG (the higher number gauges may limit distance somewhat). Standard dial-up telephone circuits, or leased circuits that run through signal equalization equipment, are **not acceptable**.

For your convenience, the Model 1010B is available with three different twisted pair interfaces: RJ-11 jack, RJ-45 jack and terminal blocks with strain relief.

4.1.1 TWISTED PAIR CONNECTION USING RJ-11 OR RJ-45

The RJ-11 and RJ-45 connectors on the Model 1010B's twisted pair interface are pre-wired for a standard TELCO wiring environment. The signal/pin relationships are shown below.

<u>RJ-11</u>	<u>SIGNAL</u>	<u>RJ-45</u>	<u>SIGNAL</u>
1.....	GND*	1	N/C
2.....	RCV-	2	GND*
3.....	XMT+	3	RCV-
4.....	XMT-	4	XMT+
5.....	RCV+	5	XMT-
6.....	GND	6	RCV+
		7	GND
		8	N/C

When connecting two Model 1010Bs, it is necessary to use a "cross over" cable. The diagram below shows how a cross over cable should be constructed for an environment where both Model 1010Bs use a 6-wire RJ-11 connector. Similar logic should be followed when using RJ-45 connectors or a combination of the two.

RJ-11 Cable (4-Wire)

SIGNAL	PIN#	PIN#	SIGNAL
GND†	1-----	6	GND†
RCV-	2-----	4	XMT-
XMT+	3-----	5	RCV+
XMT-	4-----	2	RCV-
RCV+	5-----	3	XMT+
GND†	6-----	1	GND†

Connection to ground is optional.

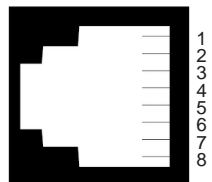
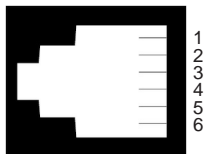

4.1.2 TWISTED PAIR CONNECTION USING TERMINAL BLOCKS

If your application requires you to connect two pairs of bare wires to the Model 1010B, you will need to open the case to access the terminal blocks. The following instructions will tell you how to open the case, connect the bare wires to the terminal blocks, and fasten the strain relief collar in place so that the wires will not pull loose.

1. Open the unit by gently inserting a screw driver between the DB-25 connector and the lip of the plastic case (see Figure 5, below). You don't have to worry about breaking the plastic, but be careful not to bend the D-sub connector.

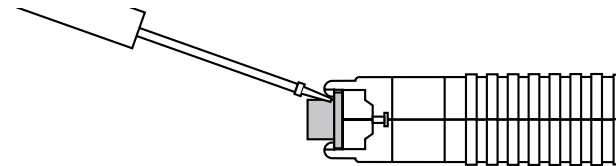

Once the unit has been opened, you will be able to see the terminal blocks located at the rear of the PC board.

2. Remove the insulation from the twisted pairs about one inch from the end.

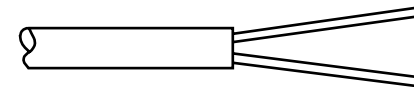

3. Remove the insulation on each of the 2 twisted pair wires about .25".

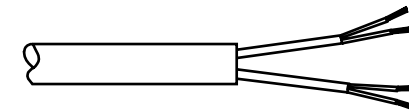

4. Connect **one pair** of wires to XMT+ and XMT- (transmit positive and negative) on the terminal block, making careful note of which color is positive, and which color is negative.
5. Connect the **other pair** of wires to RCV+ and RCV- (receive positive and negative) on the terminal block, again making careful note of which color is positive, and which color is negative.

Construct a two pair cross over cable that makes a connection between the two short range modems as shown below.

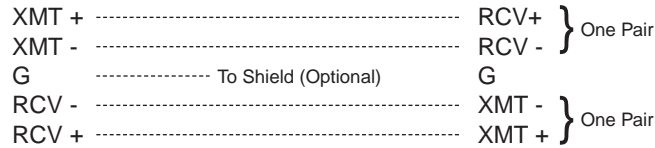

- If there is a shield around the telephone cable, it may be connected to "G" on the terminal block. To avoid ground loops, connect the shield at the computer end only. A ground wire is **not necessary** for proper operation of the Model 1010B.
- Refer to the diagram below to confirm that you have correctly assembled the device.

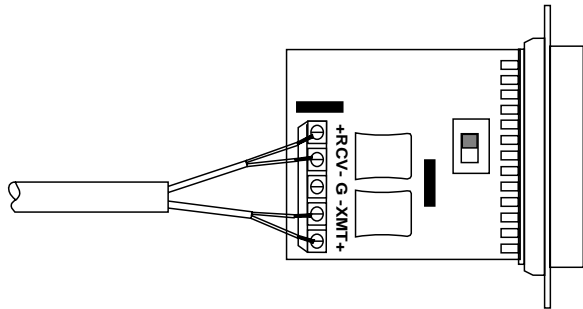

- Place the 2 halves of the strain relief assembly on either side of the telephone wire and press together very lightly. Slide the assembly so that it is about 2 inches from the terminal posts and press together firmly. If your cable diameter is too small or too large for our strain relief, please contact our technical support. We have strain relief assemblies to accommodate most cable diameters.

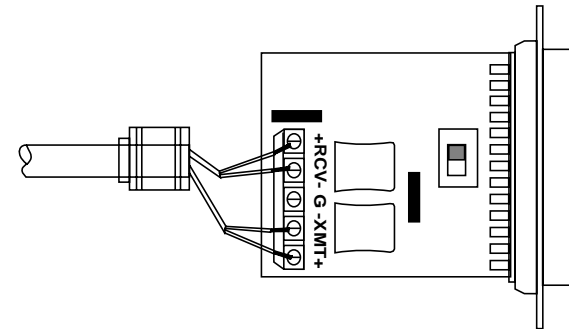

- Place the wires through the strain relief assembly. Then, insert the strain relief assembly into the slot in the bottom half of the modem case and set it into the recess in the case.

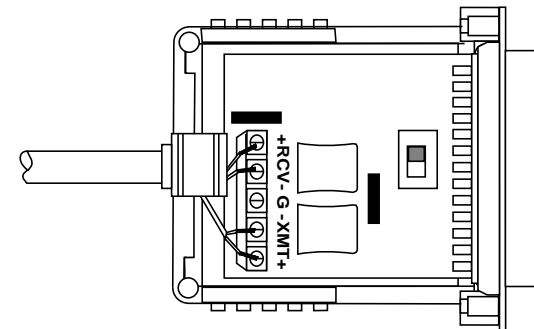

- BEND the top half of the case as necessary to place it over the strain relief assembly. Do not snap the case together yet.

11. Insert one captive screw through a saddle washer, then insert the captive screw with the washer on it through the hole in the DB-25 end of the case. Snap that side of the case closed. Repeat the process for the other side. This completes cable installation.

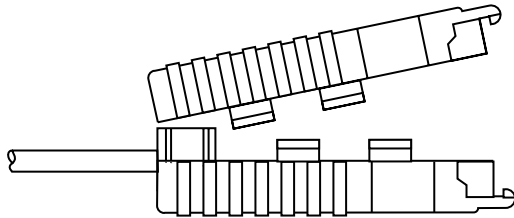

4.2 CONNECTION TO THE RS-232 INTERFACE

Once you have configured the Model 1010B for DTE or DCE and connected the twisted pair wires correctly, all that remains is to plug the 1010B directly into the DB-25 port of the RS-232 device. After doing so, remember to insert and tighten the two captive connector screws.

(Note: If you must use a cable to connect the Model 1010B to the RS-232 device, make sure it is a *straight through* cable of the shortest possible length—we recommend 6 feet or less).

4.3 OPERATING THE MODEL 1010B

Once the Model 1010B is properly installed, it should operate transparently—as if it were a standard cable connection. Operating power is derived from the RS-232 data and control signals; there is no "ON/OFF" switch. All data signals from the RS-232 interface are passed straight through. All control signals from the RS-232 interface are looped back.

NOTE: If your system requires **hardware** flow control, you will need the Patton Model 1012 Modem or Model 1060 Short Range Modem. Call Patton Technical Services at: **(301) 975-1007**; <http://www.patton.com>; or, support@patton.com.

APPENDIX A

PATTON MODEL 1010B SPECIFICATIONS

Transmission Format:	Asynchronous, full duplex
Transmission Line:	Two unconditioned twisted pair 19 - 26 AWG
Range:	See table on page 13
Interfaces:	EIA RS-232, CCITT V.24
Data Rates:	300 bps - 115.2 kbps
Isolation:	Minimum 1500V RMS using custom transformers
Surge Protection:	600W power dissipation
Dimensions:	2.66" x 2.10" x 0.73" (67.6 x 53.3 x 18.5)mm
Factory DCE/DTE Setting:	DCE (transmits from RS-232 on pin 2)
Control Signals:	DSR and DCD follow DTR from the terminal (DTE); CTS follows RTS from the terminal (DTE)
Connectors:	DB-25 male or female on RS-232 side; RJ-11, RJ-45 or terminal block with strain relief on line side
Power Supply:	None required; uses power from EIA data and control signals
Temperature Range:	0-50°C (32-122°F)
Altitude:	0-15,000 feet (0-5,000m)
Humidity:	5 to 95% noncondensing
Weight:	2 oz. (56.8 grams)

APPENDIX B

PATTON MODEL 1010B RS-232C PIN CONFIGURATIONS

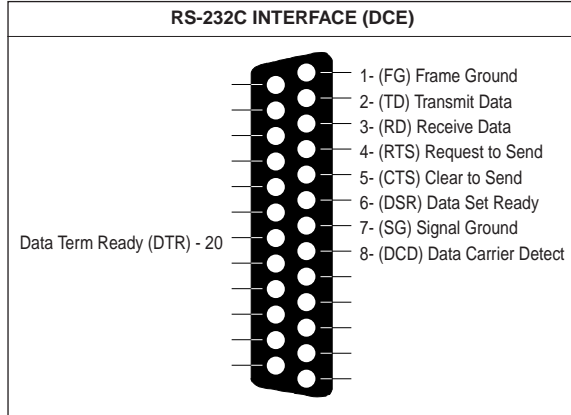

1010B Distance (miles) - Normal Mode			
Data Rate	Wire Gauge		
	19	24	26
115,200	1.7	0.9	0.6
57,600	4.2	2.3	1.6
38,400	5.2	2.8	2.0
19,200	7.3	3.6	2.5
9,600	6.9	4.1	2.9
4,800	7.3	4.3	3.0
2,400	8.0	4.7	3.3
1,200	9.5	5.6	3.6

APPENDIX C

PATTON MODEL 1010B BLOCK DIAGRAM

