

NANO-6060

NANO-ITX Board

User's Manual

Version 1.0

Copyright © Portwell, Inc., 2013. All rights reserved.
All other brand names are registered trademarks of their respective owners.

Table of Contents

How to Use This Manual

Chapter 1 System Overview	1-1
1.1 Introduction	1-1
1.2 Check List.....	1-1
1.3 Product Specification.....	1-1
1.4 System Configuration.....	1-3
1.4.1 Mechanical Drawing.....	1-4
1.5 System Architecture.....	1-5
Chapter 2 Hardware Configuration	2-1
2.1 Jumper Setting	2-1
2.2 Connector Allocation.....	2-5
Chapter 3 System Installation.....	3-1
3.1 Intel® Valleyview CPU	3-1
3.2 Main Memory	3-1
3.3 Installing the Single Board Computer.....	3-1
3.3.1 Chipset Component Driver	3-2
3.3.2 Intel® HD Graphics 4600	3-2
3.3.3 Intel LAN I210IT Gigabit Ethernet Controller	3-2
3.3.4 Realtek ALC892 HD Audio Controller	3-2
3.4 Clear CMOS Operation	3-3
3.5 WDT Function	3-4
3.6 GPIO.....	3-6
Chapter 4 BIOS Setup Information.....	4-1
4.1 Entering Setup -- Launch System Setup	4-1
4.2 Main	4-2
4.3 Advanced	4-6
4.4 Others.....	4-18
4.5 Security	4-21
4.6 Boot	4-22
4.7 Exit.....	4-23
Chapter 5 Troubleshooting	5-1
5.1 Hardware Quick Installation.....	5-1
5.2 BIOS Setting	5-2
5.3 FAQ.....	5-2
Appendix A	
Appendix B	

How to Use This Manual

The manual describes how to configure your system board to meet various operating requirements. It is divided into five chapters, with each chapter addressing a basic concept and operation of Single Host Board.

Chapter 1 : System Overview. Presents what you have in the box and give you an overview of the product specifications and basic system architecture for this series model of single host board.

Chapter 2 : Hardware Configuration. Shows the definitions and locations of Jumpers and Connectors that you can easily configure your system.

Chapter 3 : System Installation. Describes how to properly mount the CPU, main memory and Compact Flash to get a safe installation and provides a programming guide of Watch Dog Timer function.

Chapter 4 : BIOS Setup Information. Specifies the meaning of each setup parameters, how to get advanced BIOS performance and update new BIOS. In addition, POST checkpoint list will give users some guidelines of trouble-shooting.

Chapter 5 : Troubleshooting. Provides various useful tips to quickly get its running with success. As basic hardware installation has been addressed in Chapter 3, this chapter will basically focus on system integration issues, in terms of backplane setup, BIOS setting, and OS diagnostics.

The content of this manual is subject to change without prior notice. These changes will be incorporated in new editions of the document. **Portwell** may make supplement or change in the products described in this document at any time.

Updates to this manual, technical clarification, and answers to frequently asked questions will be shown on the following web site : <http://www.portwell.com.tw/>.

Chapter 1

System Overview

1.1 Introduction

Portwell Inc., a world-leading innovator in the Industrial PC (IPC) market and a member of the Intel® Communications Alliance, has launched its new NANO-ITX form factor based NANO-6060 for embedded system board (ESB) that offers lower power consumption, robust computing power and with longevity support.

The NANO-6060 is specifically designed to operate at very low power consumption and low heat, so it can be a truly fanless configuration and battery operated. Base on Intel® ATOM E3800 family SoC, the NANO-6060 supports one DDR3L SODIMM socket up to 8GB system memory and comes with two SATA II, one half size Mini-PCIe socket, multiple display by VGA, DP and 24-bit LVDS, two gigabit Ethernet, one micro SD socket and Six USB ports (two for 2.0, four for 3.0). It also built with DC 12V or ATX 12V input.

Base on leading Intel® Atom solution, NANO-6060 is a compact and low power dissipation board for Digital Signage, Digital Security Surveillance (DSS) and Medical applications...etc.

1.2 Check List

The NANO-6060 package should cover the following basic items

- ✓ One NANO-6060 NANO-ITX Main Board
- ✓ One passive Heatsink
- ✓ One Installation Resources CD-Title
- ✓ One SATA cable

If any of these items is damaged or missing, please contact your vendor and keep all packing materials for future replacement and maintain

1.3 Product Specification

- **Main Processor**
 - On board Intel® ATOM™ E3800 family SoC
- **System BIOS**
 - Phoenix uEFI BIOS
- **Main Memory**
 - One 204pin DDR3L SODIMM socket on board up to 8GB system memory

- **Power input**
 - DC 12V input on rear I/O
 - 4pin +12V power connector on board
 - (DC 12V Jack and 4pin power connector can't be used at the same time)
- **Serial Port**
 - Support one RS232/422/485 port on-board connector (adjust by bios)
- **USB Interface**
 - Support six USB (Universal Serial Bus) ports. Four are USB 3.0 (two on rear I/O and two on board header for internal devices.). Two are USB 2.0 ports.
- **SATA Interface**
 - Support two SATA II ports
- **COM port**
 - Support one on board RS232/422/485 port (select by bios)
- **SD interface**
 - Support one micro SD socket
- **Audio Interface**
 - Line-Out Audio Jack on rear I/O
 - On board pin header for Line-out, Line-in , Mic-in
- **Watch Dog Timer**
 - Support WDT function through software programming for enable/disable and interval setting
 - General system reset
- **Display**
 - Support multiple display by DP (rear I/O), VGA (on-board connector) and dual channel 24-bit LVDS
- **On-board Ethernet LAN**
 - Two Gigabit Ethernet (10/100/1000 Mbits/sec) LAN port using Intel I210IT PCI-Expressx1 interface GbE Controller
 - Support two GbE LAN on E3827 & E3845 sku, only support one GbE LAN on E3815 sku
 - Support Wake on LAN function
- **PCI Express slot**
 - Support one PCIE x1 slot
- **High Drive GPIO**
 - On-board programmable 8-bit Digital I/O interface
- **System Monitoring Feature**
 - Monitor system temperature and major power sources.
- **Outline Dimension (L x W)**
 - 120mm(4.72'') x 120mm(4.72'')

1.4 System Configuration

System Configuration	
CPU Type	Intel® Atom™ CPU E3845 1.91GHz L2 Cache 1024KB
SBC BIOS	Phoenix BIOS Portwell ,Inc NANO-6060 Test BIOS(31025T01)
EC	Version:R00.E00
Memory	WARIS DDR3L SO-DIMM 1333 1.35V/8GB (Hynix H5TC2G83EFR)
VGA Card	Onboard Intel® HD Graphics
VGA Driver	Intel® HD Graphics Version:10.18.10.3309(09/16/2013)
LAN Card	Onboard Intel® I210 Gigabit Network Connection
LAN Driver	Intel® I210 Gigabit Network Connection Version:12.7.28.0
LAN Card	Onboard Intel® I210 Gigabit Network Connection #2
LAN Driver	Intel® I210 Gigabit Network Connection #2 Version:12.7.28.0
Audio Card	Onboard Realtek ALC892 High Definition Audio
Audio Driver	Realtek ALC892 High Definition Audio Version:6.0.1.6873
Chip Driver	Intel® Bay Trail-M/D SOC Chipset Device Software Version:9.4.4.1005
Display	Intel corporation version:6.16.0.3.124(09/10/2013)
USB 3.0 Driver	Intel® USB 3.0 eXtensible Host Controller-0100 Version:6.2.9200.16656(Microsoft)
SATA HDD	Seagate ST3500411SV 500GB
CDROM	ASUS DRW-24D3ST
Power Supply	Portwell ORION-D4601 460W

- **Power Consumption test:** Run Burning Test V7.1
RUN time: 10 / 30 Minutes.

Item	Power ON	Full Loading 10Min	Full Loading 30Min
DC +12V	0.96	1.24	1.20

- **Operating Temperature**
-40°C ~ 85°C
- **Storage temperature**
-40 ~ 85 °C
- **Relative Humidity**
0% ~ 95%, non-condensing

1.4.1 Mechanical Drawing

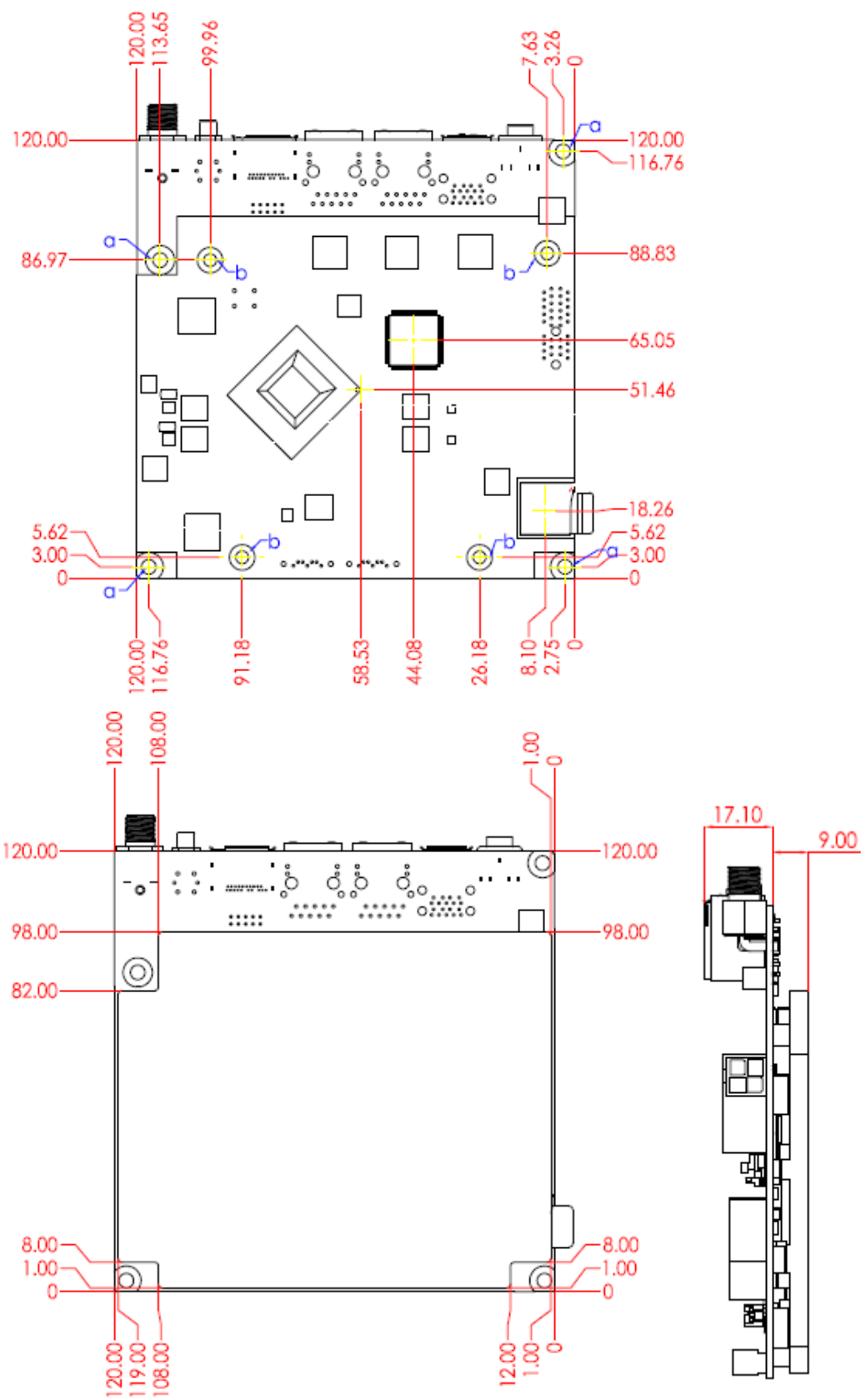

1.5 System Architecture

All of details operating relations are shown in NANO-6060 System Block Diagram.

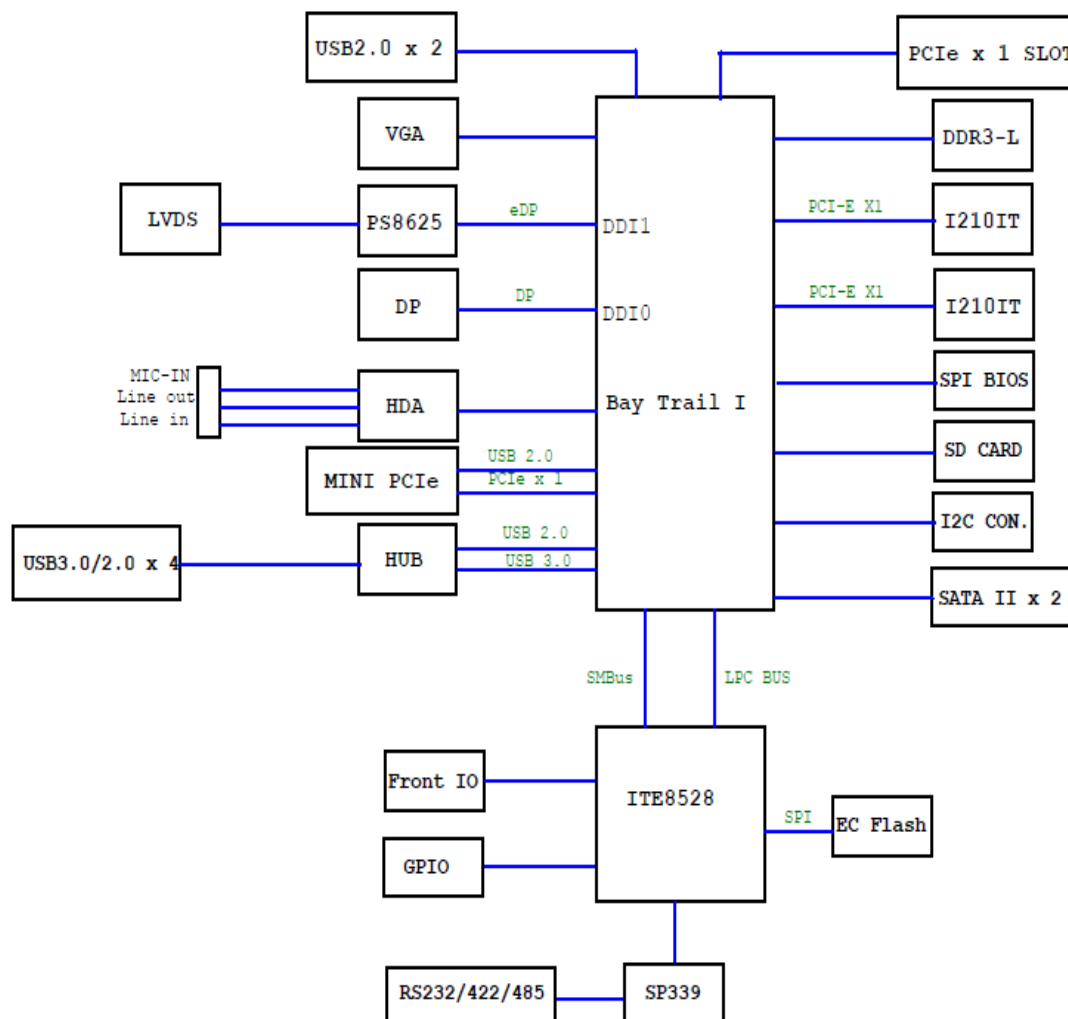

NANO-6060 System Block Diagram

Chapter 2 Hardware Configuration

This chapter gives the definitions and shows the positions of jumpers, headers and connectors. All of the configuration jumpers on NANO-6060 are in the proper position. The default settings shipped from factory are marked with an asterisk (*).

2.1 Jumper Setting

In general, jumpers on the single board computer are used to select options for certain features. Some of the jumpers are designed to be user-configurable, allowing for system enhancement. The others are for testing purpose only and should not be altered. To select any option, cover the jumper cap over (SHORT) or remove (NC) it from the jumper pins according to the following instructions. Here NC stands for "Not Connect"

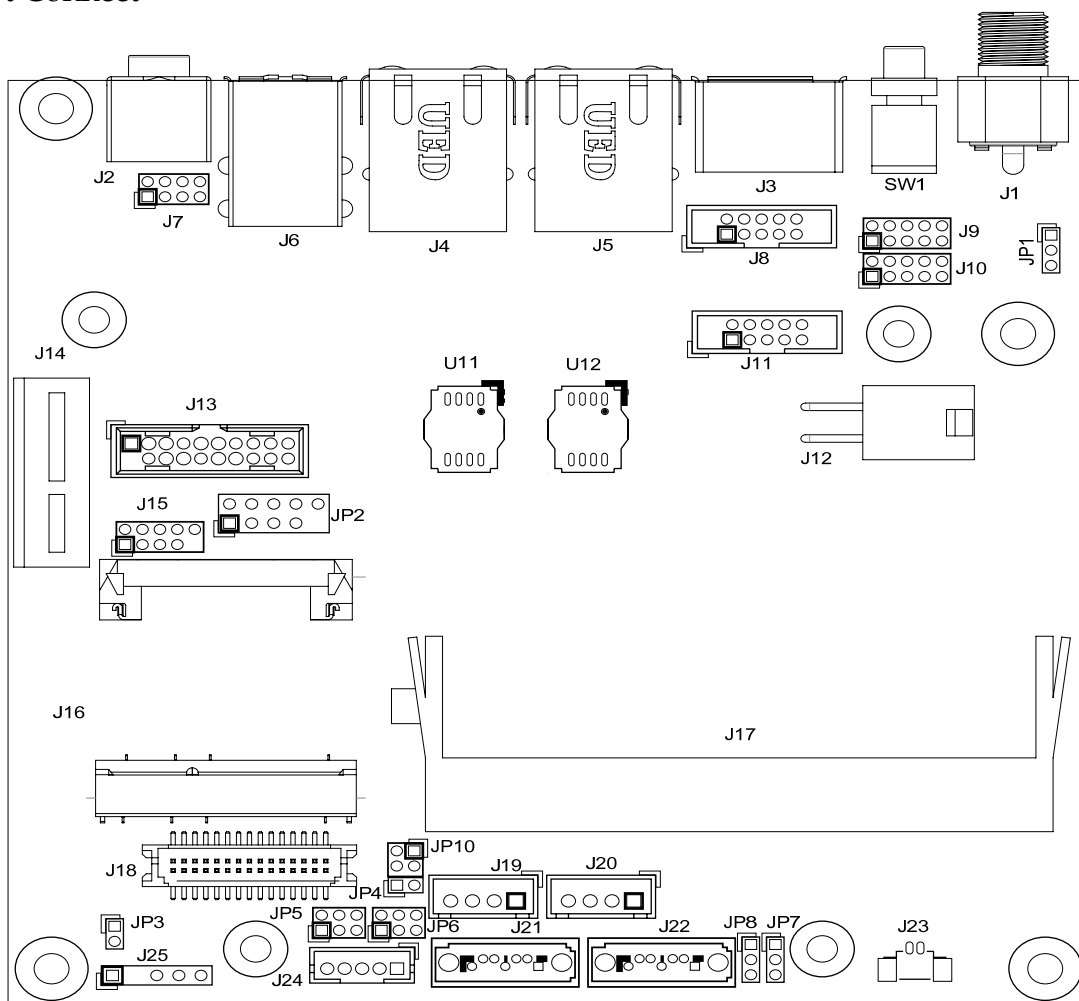
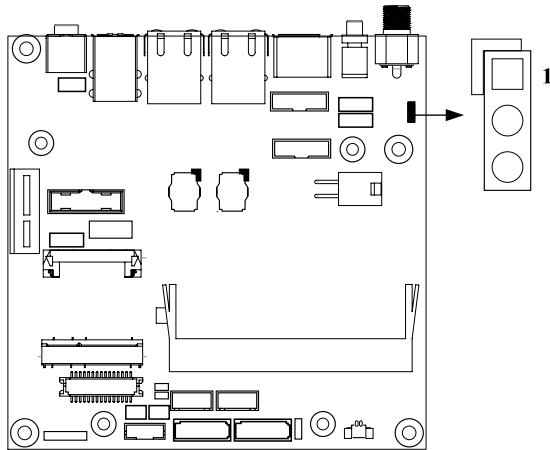

Figure 2-1 NANO-6060 Jumper and Connector Locations

JP1: GPIO4~7 Voltage Level Selection

JP1	Function
1-2 Short	5V (output)
2-3 Short	3.3V (Input) ★



JP3: LVDS Link Selection

JP3	Function
Short	Dual Link ★
Open	Single Link

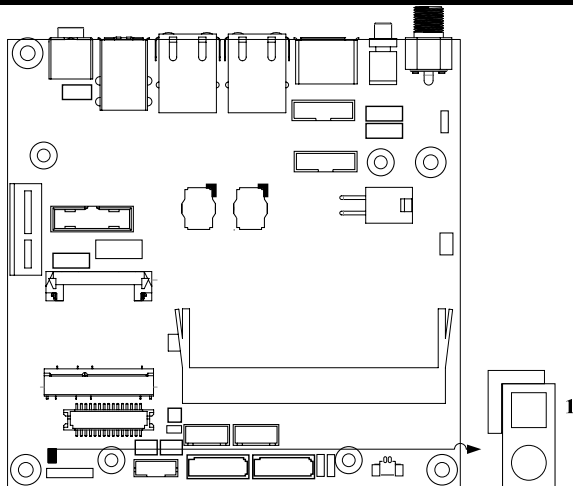

JP5 : PANEL Voltage Selection

JP5	Function
1-3 Short	VCC3 ★
3-5 Short	VCC
3-4 Short	+12V

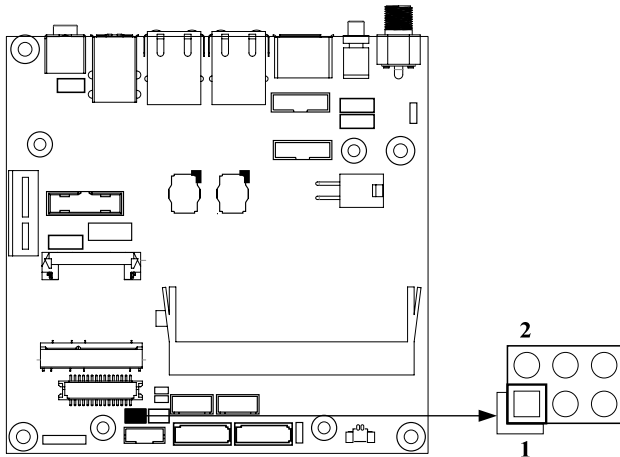

JP6: PANEL BACKLIGHT Selection

Pin No.	Signal Description
1-3, 2-4	5V, Active High ★
1-3, 4-6	12V, Active High
3-5, 2-4	5V, Active Low
3-5, 4-6	12V, Active Low

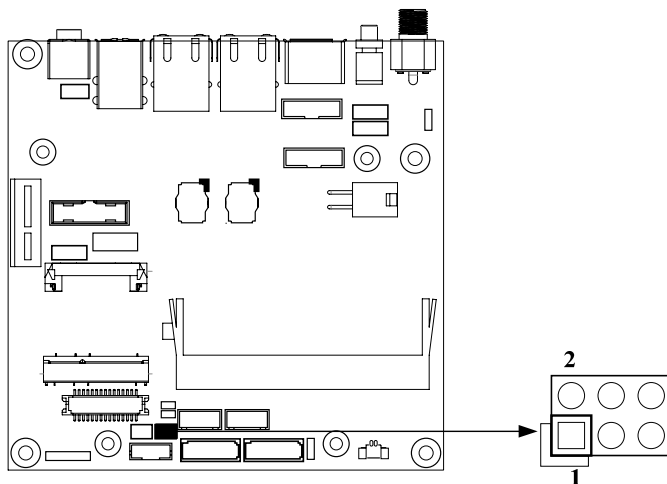

JP7/JP8 : CMOS Clear

JP7/8	Function
1-2 Short	Normal Operation ★
2-3 Short	Clear CMOS Contents

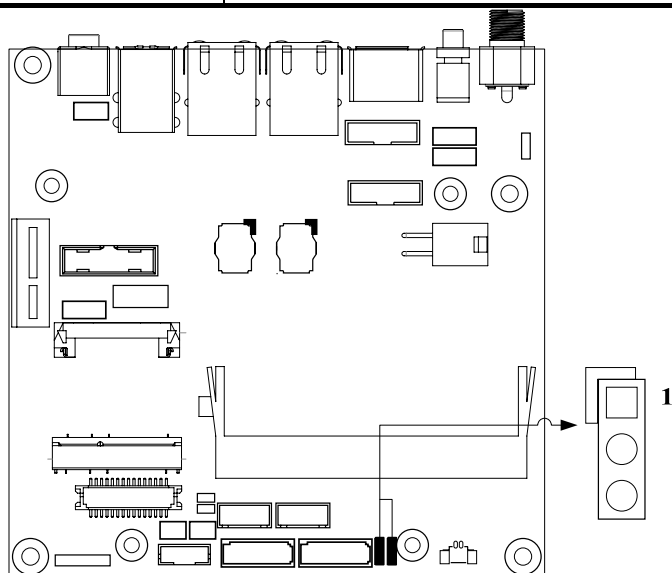

JP10 : LVDS Color Depth and Data Mapping

JP10	Function
2-4 Short	8-bit LVDS , VESA mapping ★
1-3 , 2-4 Short	8-bit LVDS , JEIDA mapping
1-3 Short	6-bit LVDS , VESA and JEIDA mapping

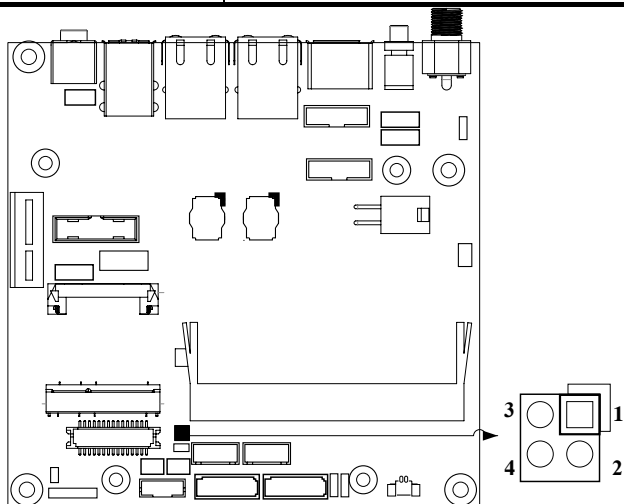

SW2 : Power on / BIOS Recovery selection

SW2	Function
1-4 OFF	ATX ★
1-4 ON	AT
2-3 OFF	Recovery Disable ★
2-3 ON	Recovery Enable

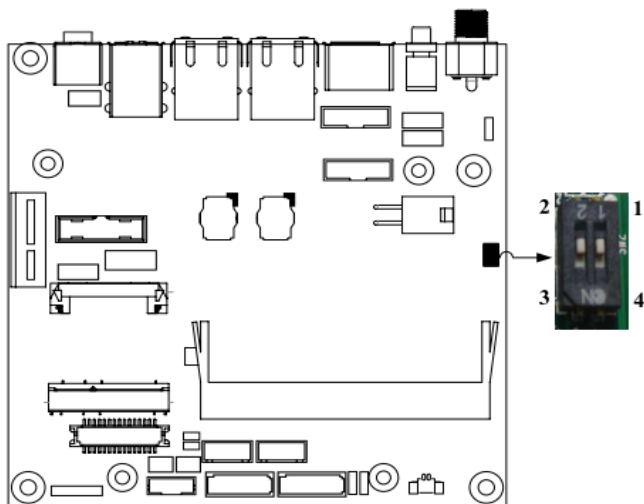
**2.2 Connector Allocation**

I/O peripheral devices and Flash disk will be connected to these interface connectors

Connector	Description	Remark
J1	DC Jack	+12V Input
J2	Audio Jack (Line_out)	
J3	DP Port	
J4/J5	RJ45 Connector	
J6	USB3 Connector	
J7	External Audio (Mic + Line_in + Line_out) Pin HDR.	4x2 pin header
J8	VGA Pin HDR.	5x2 pin header
J9	Front Panel Pin HDR	5x2 pin header
J10	General Purpose I/O Pin HDR	5x2 pin header
J11	RS232/422/485 Pin HDR	5x2 pin header
J12	ATX 4 Pin Connector	+12V Input
J13	External USB3 Connector	
J14	PCIe x 1 SLOT	
J15	External USB2 Connector	

J16	Mini PCIe Connector	
J17	DDR3 SO-DIMM Socket	
J18	LVDS Connector	
J19/J20	SATA Power Connector	
J21/J22	SATA GEN2 Connector	

J7 : External Audio Connector

PIN No.	Signal Description	PIN No.	Signal Description
1	MIC_L	2	Line_in_L
3	Ground	4	Line_in_R
5	Line_out_L	6	Ground
7	Line_out_R	8	MIC_R

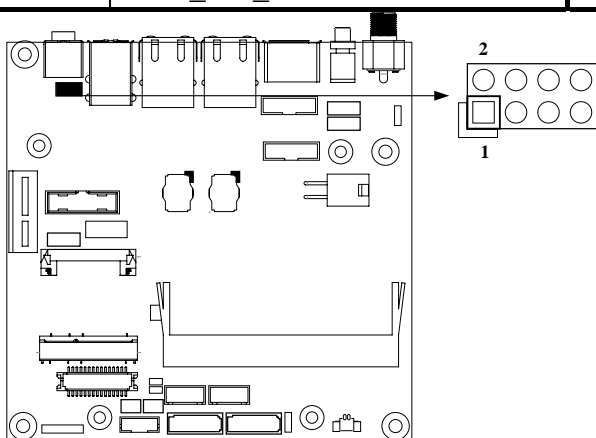

J8 : VGA Connector

PIN No.	Signal Description	PIN No.	Signal Description
1	RED	2	SCL
3	GREEN	4	GND
5	BLUE	6	SDA
7	VSYNC	8	GND
9	HSYNC	10	+5V

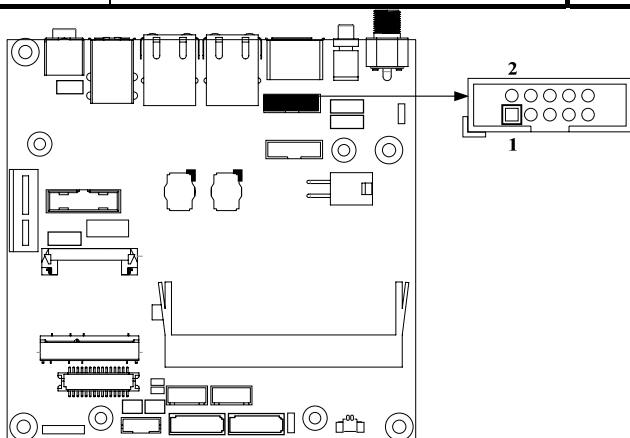

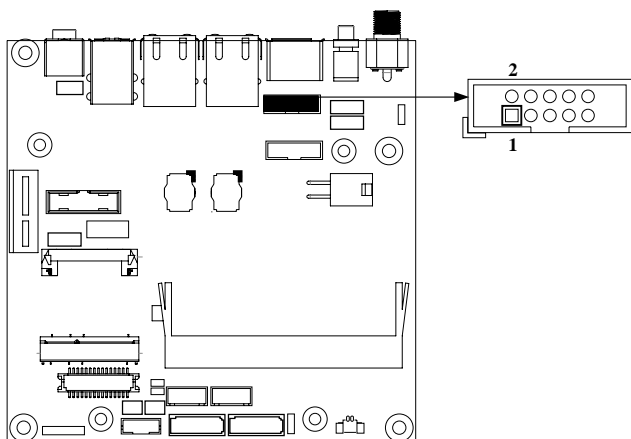

J9 : Front Panel Pin HDR(J9)

PIN No.	Signal Description	PIN No.	Signal Description
1	Ground	2	N/C
3	+5V	4	N/C
5	HDD_LED(+)	6	HDD_LED(-)
7	Reset (+)	8	Power On(-)
9	Reset (-)	10	Power On(+)

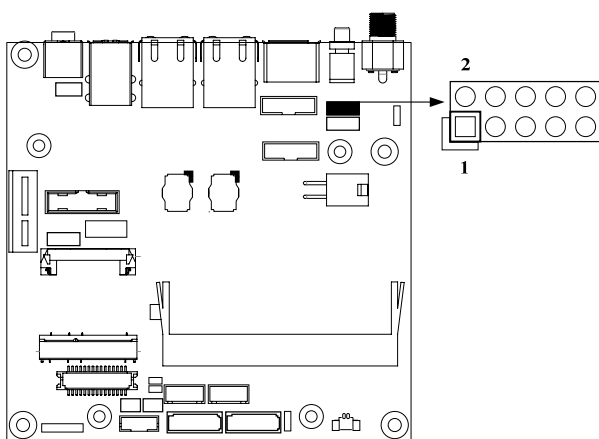

J10: General Purpose I/O Connector

PIN No.	Signal Description	PIN No.	Signal Description
1	GPIO0	2	GPIO4
3	GPIO1	4	GPIO5
5	GPIO2	6	GPIO6
7	GPIO3	8	GPIO7
9	Ground	10	+5V

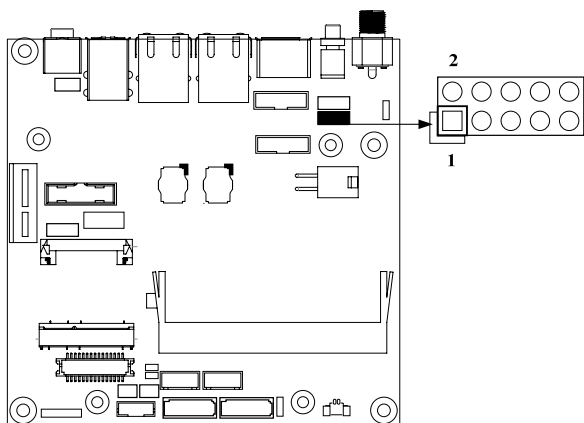

J11: RS-232/422/485 I/O Connector

PIN No.	Signal Description	PIN No.	Signal Description
1	DCD#/485D-/422T-	2	RXD#/485D+/422T+
3	TXD#/422R+	4	DTR#/422R-
5	Ground	6	DSR#
7	RTS#	8	CTS#
9	RI#	10	N/C

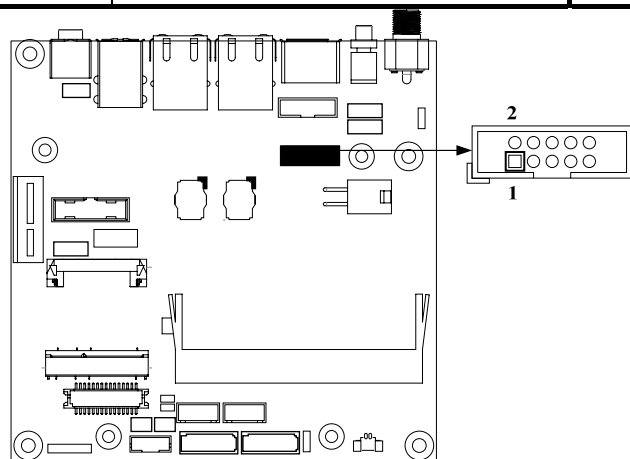

J13 : External USB3 Connector

PIN No.	Signal Description	PIN No.	Signal Description
1	5V always	11	USB2_DP_#3
2	USB3_RXM_#1	12	USB_DM_#3
3	USB3_RXP_#1	13	Ground
4	Ground	14	USB3_TXP_#3
5	USB3_TXM_#1	15	USB3_TXM_#3
6	USB3_TXP_#1	16	Ground
7	Ground	17	USB3_RXP_#3
8	USB2_DM_#1	18	USB3_RXM_#3
9	USB2_DP_#1	19	5V always
10	Ground	20	Key(no pin)

Note:

5V Dual is always available. It's supplied by either 5V VCC power source in normal operation mode or 5V standby power source in standby mode.

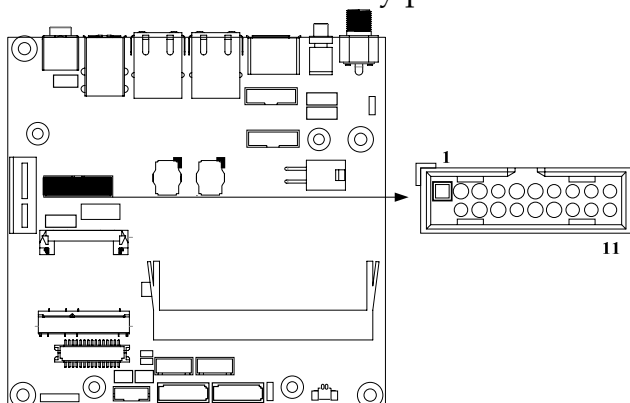

J15 : External USB Connector

PIN No.	Signal Description	PIN No.	Signal Description
1	5V always	2	5V always
3	USB-	4	USB-
5	USB+	6	USB+
7	Ground	8	Ground
9	Key(no pin)	10	N/C

Note:

5V Dual is always available. It's supplied by either 5V VCC power source in normal operation mode or 5V standby power source in standby mode.

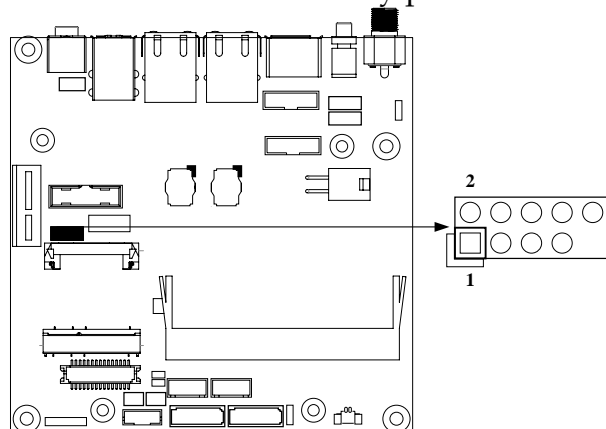

J18 : LVDS Connector

PIN No.	Signal Description	PIN No.	Signal Description
1	VDD_LVDS	2	VDD_LVDS
3	LVDSA_DATA0	4	LVDSA_DATA#0
5	LVDSA_DATA1	6	LVDSA_DATA#1
7	LVDSA_DATA2	8	LVDSA_DATA#2
9	LVDSA_DATA3	10	LVDSA_DATA#3
11	LVDSA_CLKP	12	LVDSA_CLKN
13	DDC_SCL	14	DDC_SDA
15	Ground	16	Ground
17	LVDSB_DATA0	18	LVDSB_DATA#0
19	LVDSB_DATA1	20	LVDSB_DATA#1
21	LVDSB_DATA2	22	LVDSB_DATA#2
23	LVDSB_DATA3	24	LVDSB_DATA#3
25	LVDSB_CLKP	26	LVDSB_CLKN
27	N/C	28	N/C
29	Ground	30	Ground

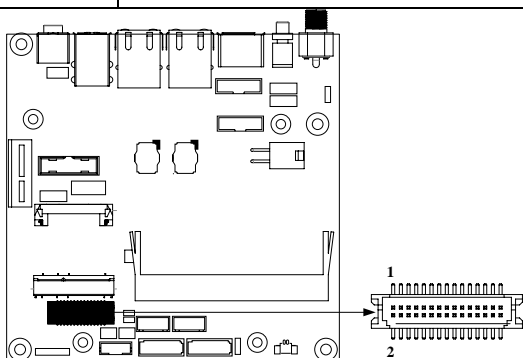

J19/J20 : SATA Power Connector

Pin No.	Signal Description
1	+12V
2	Ground
3	Ground
4	+5V

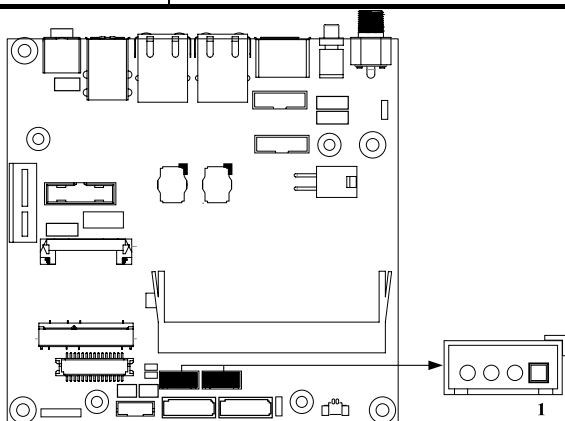

J23 : Battery Connector

Pin No.	Signal Description
1	Battery Voltage
2	Ground

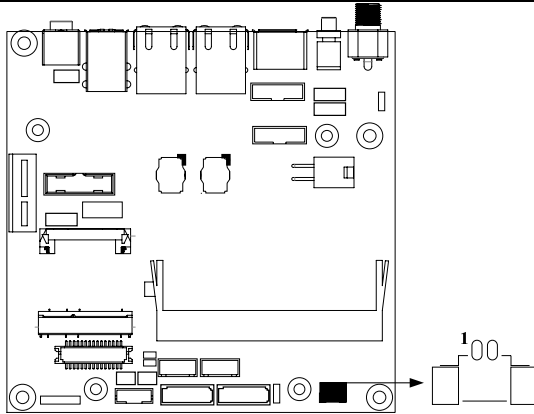

J24 : Back light Connector

Pin No.	Signal Description
1	+5V
2	BL_CTRL
3	+12V
4	Ground
5	BL_Enable

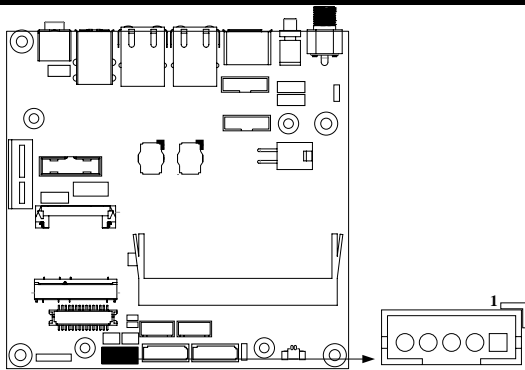

J25 : SMBUS Connector

Pin No.	Signal Description
1	SMB_CLK
2	Key(no pin)
3	Ground
4	+5V
5	SMB_DATA

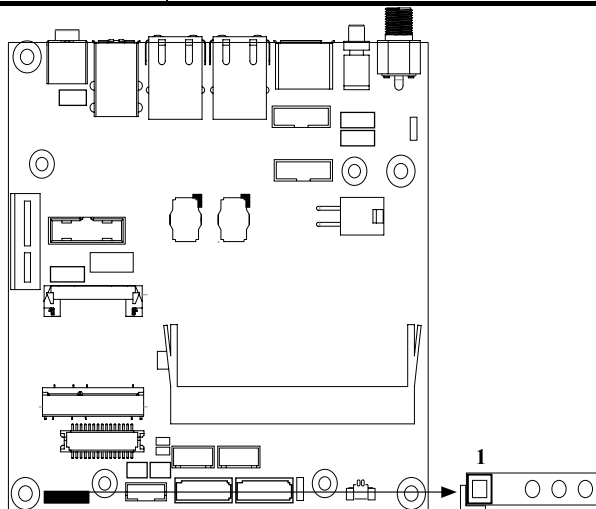

Chapter 3

System Installation

This chapter provides you with instructions to set up your system. The additional information is enclosed to help you set up onboard PCI device and handle Watch Dog Timer (WDT) and operation of GPIO in software programming.

3.1 Intel® Valleyview CPU

Intel® E3845 (4 core, 10W, 1.91GHz, 1333MT)

Intel® E3827 (2 core, 8W, 1.75GHz, 1333MT)

Intel® E3815 (1 core, 5W, 1.46GHz, 1067MT)

3.2 Main Memory

NANO-6060 provides 1 x 204-pin SO-DIMM sockets which supports DDR3L non-ECC memory. The maximum memory can be up to 8GB. Memory clock and related settings can be detected by BIOS via SPD interface.

Watch out the contact and lock integrity of memory module with socket, it will impact on the system reliability. Follow normal procedures to install memory module into memory socket. Before locking, make sure that all modules have been fully inserted into the card slots.

3.3 Installing the Single Board Computer

To install your NANO-6060 into standard chassis or proprietary environment, please perform the following:

Step 1 : Check all jumpers setting on proper position

Step 2 : Install and configure CPU and memory module on right position

Step 3 : Place NANO-6060 into the dedicated position in the system

Step 4 : Attach cables to existing peripheral devices and secure it

WARNING

Please ensure that mother board is properly inserted and fixed by mechanism.

Note:

Please refer to section 3.3.1 to 3.3.4 to install INF/Graphic/LAN/Audio drivers.

3.3.1 Chipset Component Driver

NANO-6060 uses state-of-art Intel® BayTrail-I Soc. It's a new chipset that some old operating systems might not be able to recognize. To overcome this compatibility issue, for Windows Operating Systems such as Windows 8, please install its INF before any of other Drivers are installed. You can find very easily this chipset component driver in NANO-6060 CD-title

3.3.2 Intel® HD Graphics 4600

NANO-6060 has integrated Intel® HD Graphics 4600 which supports DX-11, OpenGL-4.0. It is the most advanced design to gain an outstanding graphic performance. NANO-6060 supports VGA, DP, dual channel 24 bit LVDS. This combination makes NANO-6060 an excellent piece of multimedia hardware.

Drivers Support

Please find the Graphic driver in the NANO-6060 CD-title. The driver supports Windows 8.

3.3.3 Intel LAN I210IT Gigabit Ethernet Controller

- Dual Intel I210IT Gigabit Ethernet controller and 2x RJ45 connectors on rear I/O for E3827/ E3845 only

- Single Intel I210IT Gigabit Ethernet controller and 1xRJ45 connector on rear I/O for E3815

Drivers Support

Please find Intel I210IT LAN driver in /Ethernet directory of NANO-6060 CD-title. The driver supports Windows 8.

3.3.4 Realtek ALC892 HD Audio Controller

Please find Realtek ALC892 HD Audio driver form NANO-6060 CD-title. The driver supports Windows 8.

3.4 Clear CMOS Operation

The following table indicates how to enable/disable Clear CMOS Function hardware circuit by putting jumper in the board.

JP7/JP8 : CMOS Clear

JP7/8.	Function
1-2 Short	Normal Operation
2-3 Short	Clear CMOS Contents

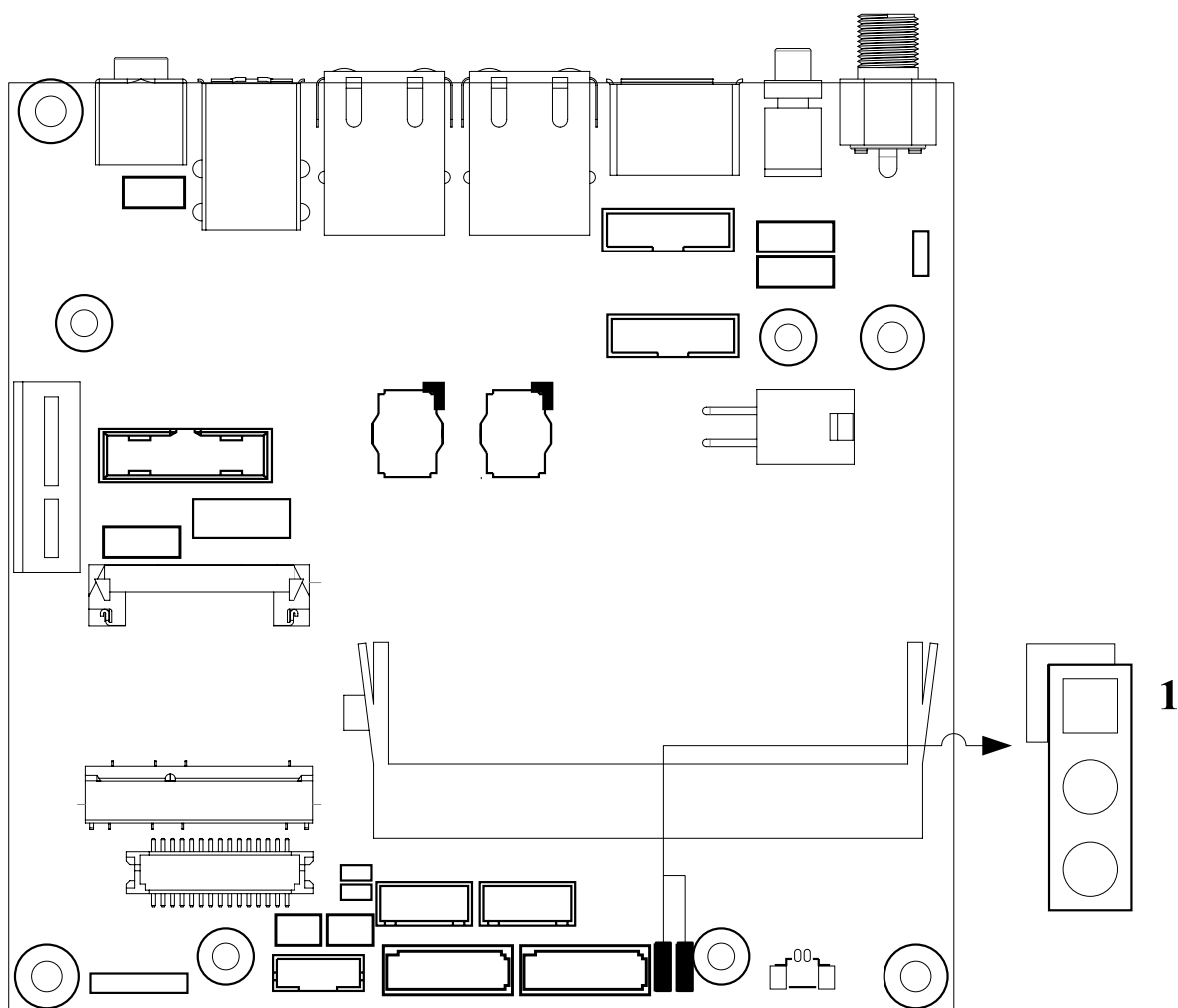

3.5 WDT Function

```
#include <stdio.h>
#include <stdlib.h>
#include <conio.h>
#include <dos.h>

#define EC_DATA          0x62
#define EC_CMD          0x66
#define EC_CMD_READ    0x80
#define EC_CMD_WRITE   0x81

#define WDT_MODE       0x06 // WDT Select mode.
#define WDT_MIN        0x07 // Minute mode counter
#define WDT_SEC        0x08 // Second mode counter

// Use port 62 and port 66 to access EC command / data.
static int IBF_Check()
{
    unsigned char IBF_status;
    do
    {
        pw_udelay (20); // delay 20 us
        outportb (EC_CMD, &IBF_status);
    } while (IBF_status & 0x02);
    return 1;
}

static int OBF_Check ()
{
    unsigned char OBF_status;
    do
    {
        pw_udelay (20); // delay 20 us
        OBF_status = inportb (EC_CMD);
    } while (!(OBF_status & 0x01));
    return 1;
}

static void Write_EC (unsigned char index, unsigned char data)
{
    IBF_Check ();
    outportb (EC_CMD, EC_CMD_WRITE);
    IBF_Check ();
    outportb (EC_DATA, index);
}
```



```
        IBF_Check ();
        outportb (EC_DATA, data);
    }

static unsigned char Read_EC (unsigned char address)
{
    unsigned char data;
    IBF_Check ();
    outportb (EC_CMD, EC_CMD_READ);
    IBF_Check ();
    outportb (EC_DATA, address);
    OBF_Check();
    data = inportb (EC_DATA);
    return data;
}

void EC_WDT_Trigger ()
{
    /* WDT Counter */
    Write_EC (WDT_SEC, 0x05);
    /* if use minute mode */
    /* Write_EC (WDT_MIN, 0x05); */

    /* 0x01 is second mode */
    /* 0x03 is minute mode */
    Write_EC (WDT_MODE, 0x01);
}

Write_EC ((b->wdt.ec.count_m_addr & 0xFF), b->wdt.ec.timeout);
Write_EC ((b->wdt.ec.cfg_addr & 0xFF), 0x03); //
WDTCFG[1:0]=11
int main ()
{
    int i;
    EC_WDT_Trigger ();
    for (i = 0; i < 5; i++)
    {
        printf ("Reset counter .....%d\n", 5 - i);
        delay (1000);
    }
    return 0;
}
```

3.6 GPIO

```
#include <stdio.h>
#include <stdlib.h>
#include <conio.h>
#include <dos.h>

#define EC_DATA          0x62
#define EC_CMD           0x66
#define EC_CMD_READ     0x80
#define EC_CMD_WRITE    0x81

#define GPIO_DIR        0x2B // GPIO Direction (Input/Output) Reg.
#define GPIO_DATA      0x2C // GPIO High/Low Reg.

// Use port 62 and port 66 to access EC command / data.
static int IBF_Check()
{
    unsigned char IBF_status;
    do
    {
        pw_udelay (20); // delay 20 us
        outportb (EC_CMD, &IBF_status);
    } while (IBF_status & 0x02);
    return 1;
}

static int OBF_Check ()
{
    unsigned char OBF_status;
    do
    {
        pw_udelay (20); // delay 20 us
        OBF_status = inportb (EC_CMD);
    } while (!(OBF_status & 0x01));
    return 1;
}

static void Write_EC (unsigned char index, unsigned char data)
{
    IBF_Check ();
    outportb (EC_CMD, EC_CMD_WRITE);
    IBF_Check ();
    outportb (EC_DATA, index);
}
```

```
    IBF_Check ();
    outportb (EC_DATA, data);
}

static unsigned char Read_EC (unsigned char address)
{
    unsigned char data;
    IBF_Check ();
    outportb (EC_CMD, EC_CMD_READ);
    IBF_Check ();
    outportb (EC_DATA, address);
    OBF_Check();
    data = inportb (EC_DATA);
    return data;
}

int main ()
{
    unsigned char d2;
    printf("\n\n");
    printf("NANO-6060 GPIO TEST Program v1.0\n");
    printf("Please short the following pins with 2.54mm-pitched jumper on
JP8\n");
    printf("PIN 1,3,5,7 is output ; PIN 2,4,6,8 is input\n");
    printf("GPIO1 ---- GPIO5\n");
    printf("GPIO2 ---- GPIO6\n");
    printf("GPIO3 ---- GPIO7\n");
    printf("GPIO4 ---- GPIO8\n");
    printf("GND   xxxx Vcc <==PWR/GND pins, DO NOT short them!\n\n");
    printf("Test Begins...\n");

    /* Set GPIO Port In/Out mode */
    /* Port 1 ~ 4 Out mode, 5 ~ 8 In mode*/
    Write_EC (GPIO_DIR, 0xF0);
    delay (5);

    /* Set Port 1 ~ 4 Low, 5 ~ 8 High */
    outportb (0x22E, 0xF0);
    Write_EC (GPIO_DATA, 0xF0);
    delay (5);

    d2 = Read_EC (GPIO_DIR);

    if ((d2 & 0x10) == 0)
        printf ("GPIO70->GPIO74 test ok !! (pull low)\n");
    else
```

```
        printf ("GPIO70->GPIO74 test fail (pull high) \n");  
    if ((d2 & 0x20) == 0)  
        printf ("GPIO71->GPIO75 test ok !! (pull low)\n");  
    else  
        printf ("GPIO71->GPIO75 test fail (pull high)\n");  
  
    if ((d2 & 0x40) == 0)  
        printf ("GPIO72->GPIO76 test ok !! (pull low)\n");  
    else  
        printf ("GPIO72->GPIO76 test fail (pull high)\n");  
  
    if ((d2 & 0x80) == 0)  
        printf ("GPIO73->GPIO77 test ok !! (pull low)\n");  
    else  
        printf ("GPIO73->GPIO77 test fail (pull high)\n");  
    return 0;  
}
```

Chapter 4

BIOS Setup Information

NANO-6060 is equipped with the Phoenix BIOS stored in Flash ROM. These BIOS has a built-in Setup program that allows users to modify the basic system configuration easily. This type of information is stored in CMOS RAM so that it is retained during power-off periods. When system is turned on, NANO-6060 communicates with peripheral devices and checks its hardware resources against the configuration information stored in the CMOS memory. If any error is detected, or the CMOS parameters need to be initially defined, the diagnostic program will prompt the user to enter the SETUP program. Some errors are significant enough to abort the start up.

4.1 Entering Setup -- Launch System Setup

Power on the computer and the system will start POST (Power On Self Test) process. When the message below appears on the screen, press <F2> key will enter BIOS setup screen.

Press <F2> to enter SETUP

If the message disappears before responding and still wish to enter Setup, please restart the system by turning it OFF and On or pressing the RESET button. It can be also restarted by pressing <Ctrl>, <Alt>, and <Delete> keys on keyboard simultaneously.

Press <F1> to Run General Help or Resume

The BIOS setup program provides a General Help screen. The menu can be easily called up from any menu by pressing <F1>. The Help screen lists all the possible keys to use and the selections for the highlighted item. Press <Esc> to exit the Help screen.

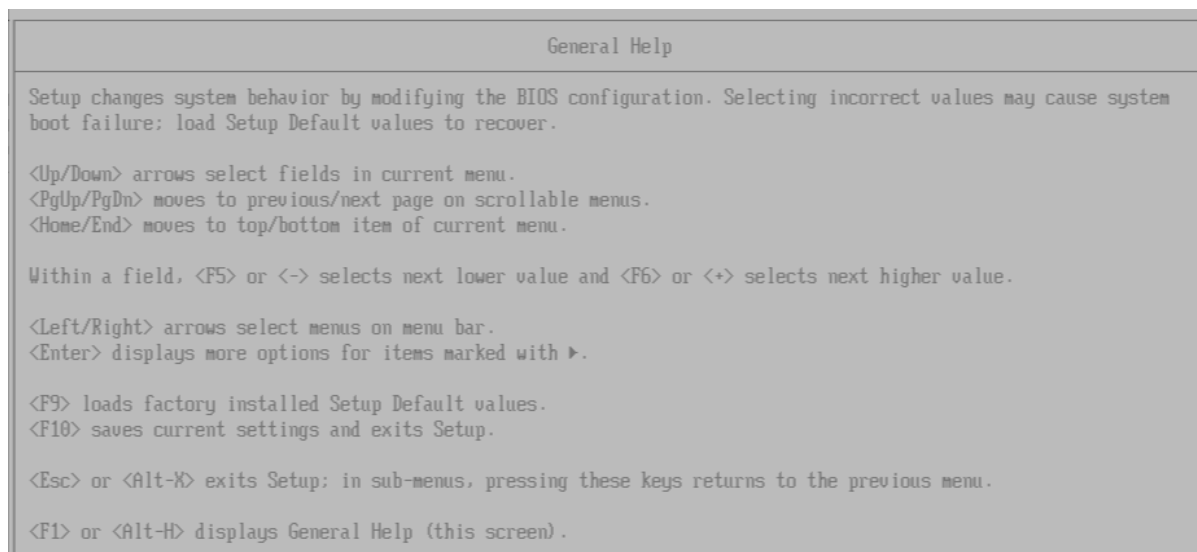

4.2 Main

Main

Use this menu for basic system configurations, such as time, date etc.

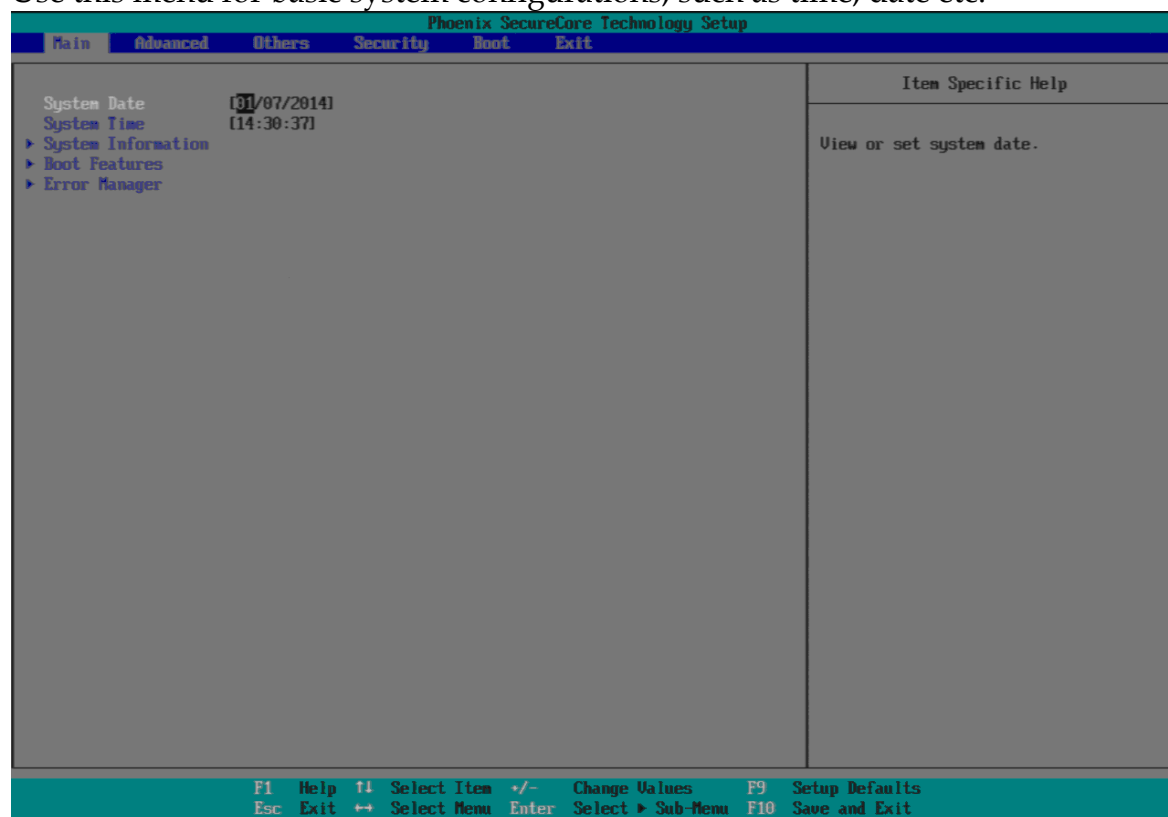

System Date

View or set system date

The date format is <Day>, <Month> <Date> <Year>. Use [+] or [-] to configure system Date.

System Time

View or set system time

The time format is <Hour> <Minute> <Second>. Use [+] or [-] to configure system Time.

System Information

Display System Information

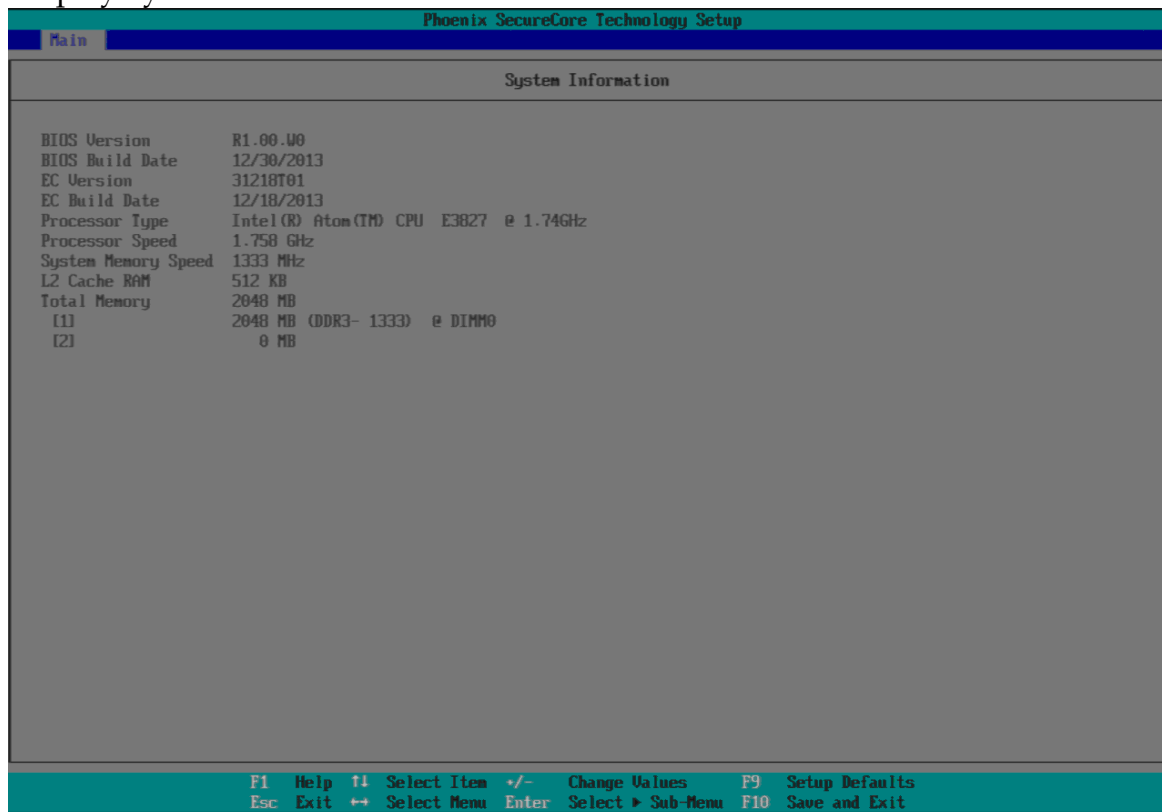

Boot Features

Select Boot features

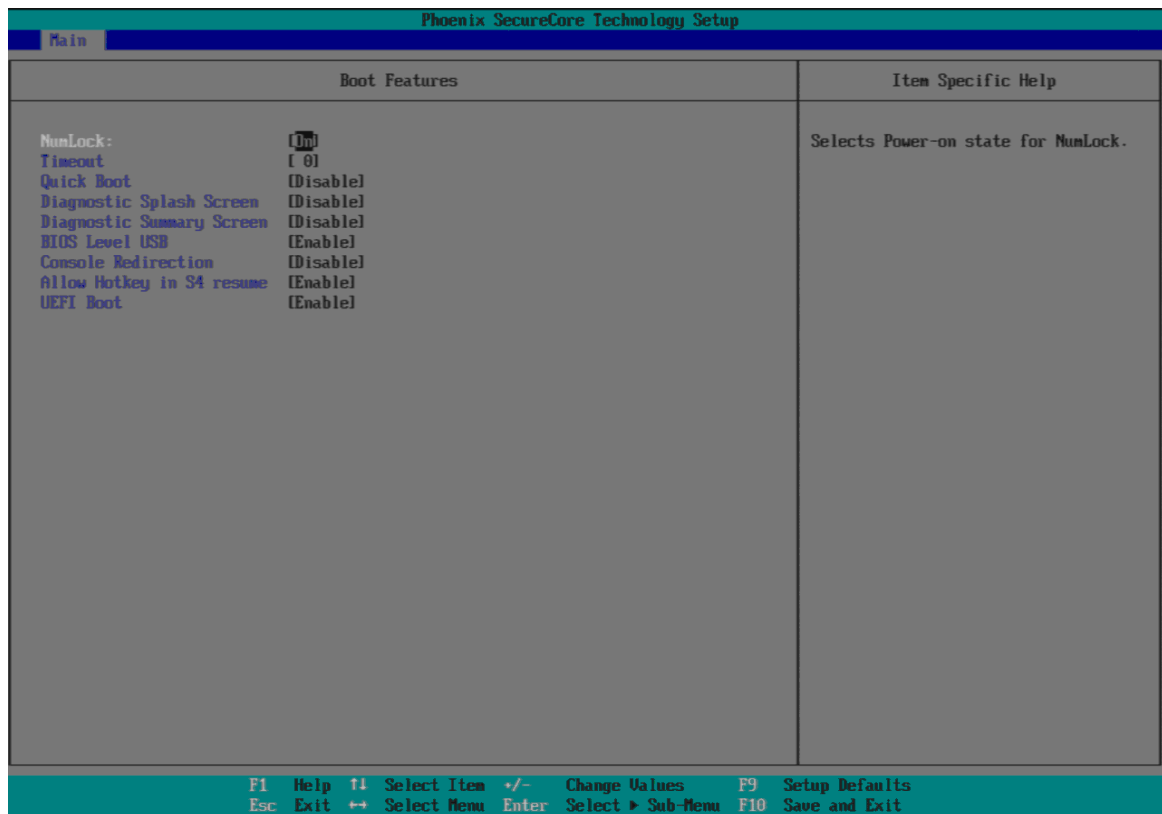

NumLock:

Selects Power-on state for NumLock

Choices: On, Off.

Timeout

Number of seconds that P.O.S.T will wait for the user input before booting

Choices: 0-99 seconds.

Quick Boot

Enable/Disable quick boot

Choices: Disable, Enable.

Diagnostic Splash Screen

If you select 'Enabled' the diagnostic splash screen always displays during boot. If you select 'Disabled' the diagnostic splash screen does not display unless you press HOTKEY during boot

Choices: Disable, Enable.

Diagnostic Summary Screen

Display the Diagnostic summary screen during boot

Choices: Disable, Enable.

BIOS Level USB

Enable/Disable all BIOS support for USB in order to reduce boot time. Note that this will prevent using a USB keyboard in setup or a USB biometric scanner such as a finger print reader to control access to setup, but does not prevent the operating system from supporting such hardware

Choices: Disable, Enable.

Console Redirection

Enable/Disable Universal Console Redirection

Choices: Disable, Enable.

Allow Hotkey in S4 Resume

Enable hotkey detection when system resuming from Hibernate state

Choices: Disable, Enable.

UEFI Boot

Enable the UEFI boot.

Choices: Disable, Enable.

Error Manager

Display Error Manager Log information.

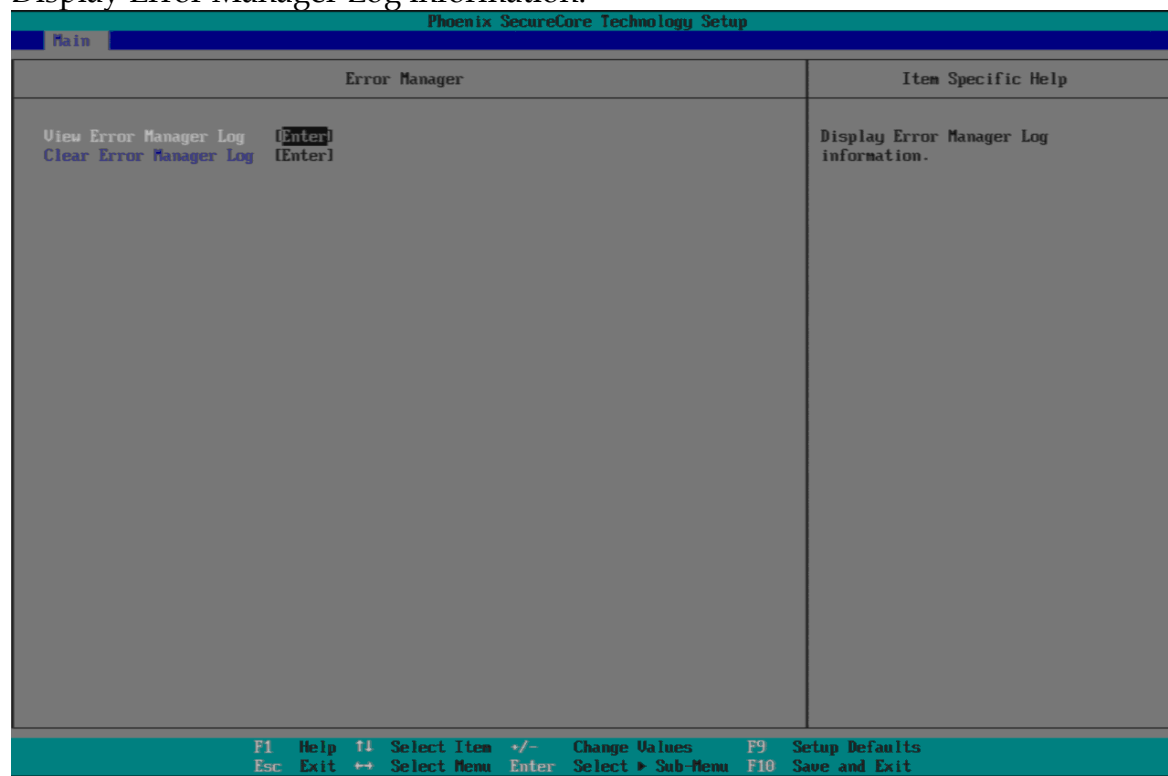

View Error Manager Log

Display Error Manager Log information

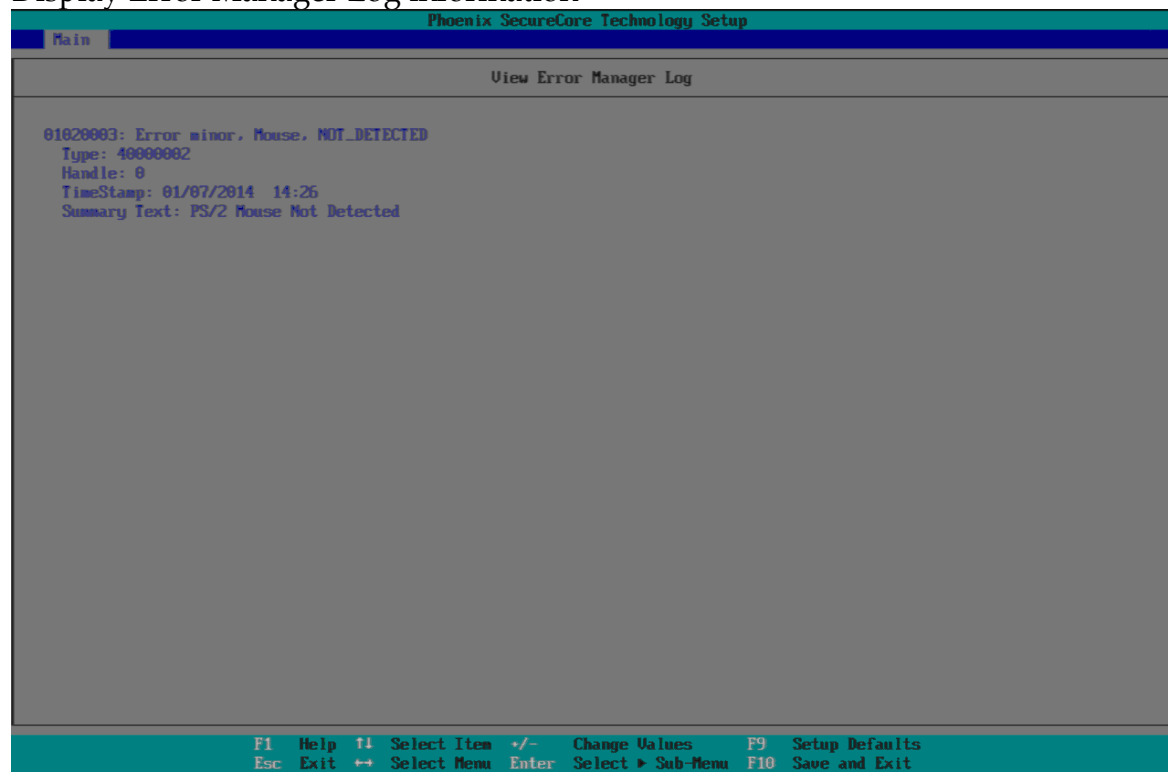

Clear Error Manager Log

Clear Error Manager Log.

4.3 Advanced

Setup Warning:

Setting items on this screen to incorrect values may cause system to malfunction!

Advanced

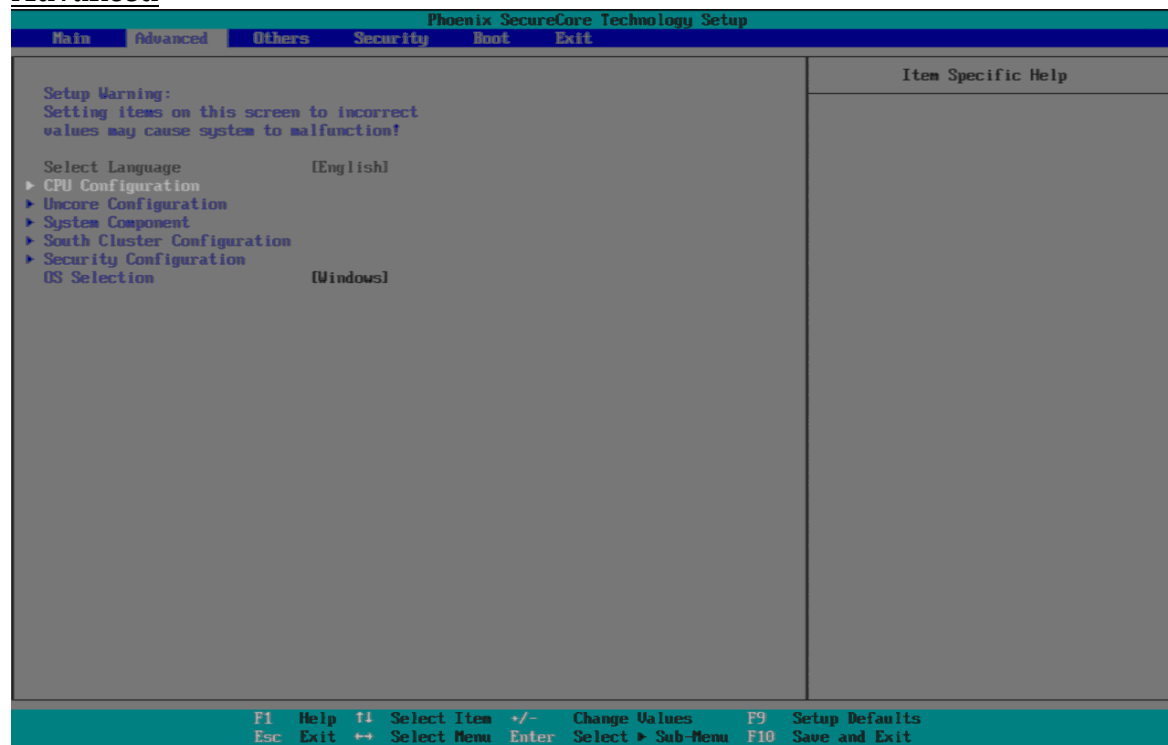

CPU Configuration

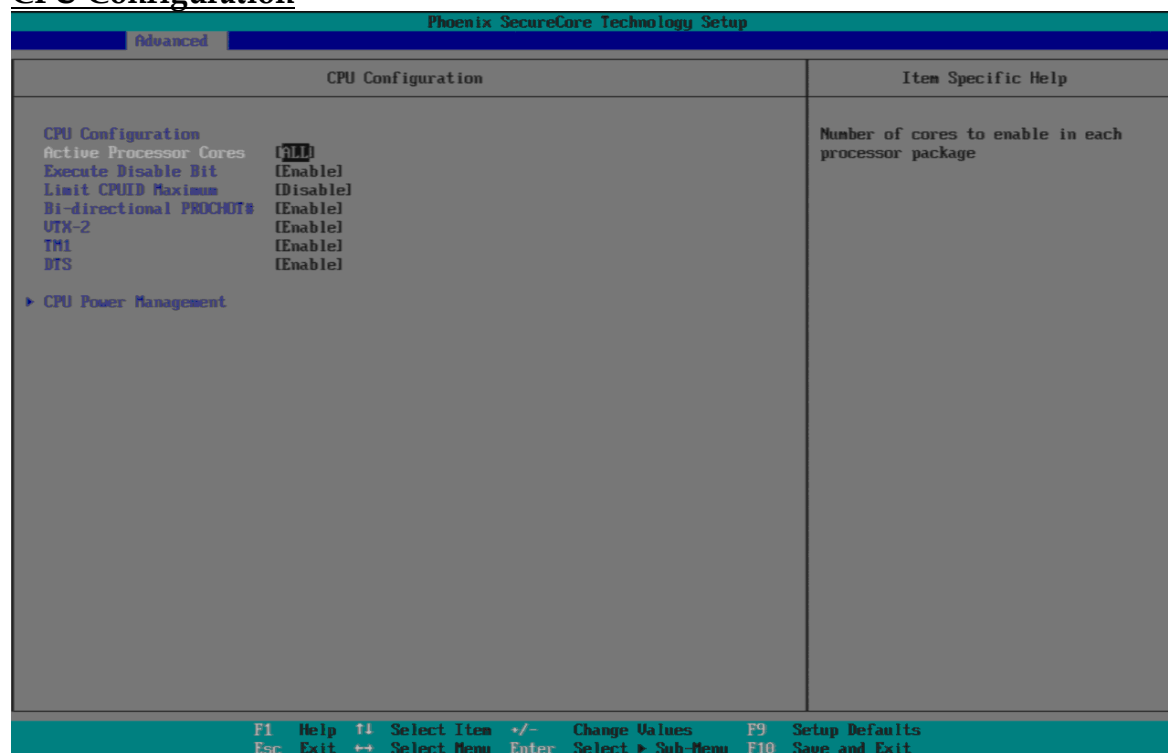

Active Processor Cores

Number of cores to enable in each processor package

Choices: All, 1.

Execute Disabled Bit

Execute Disabled Bit prevent certain classes of malicious buffer overflow attacks when combined with a supporting OS

Choices: Disable, Enable.

Limit CUID Maximum

Disabled for Windows XP

Choices: Disable, Enable.

Bi-directional PROCHOT#

When a processor thermal sensor trips (either core), the PROCHOT# will be driven
If bi-direction is enabled, external agents can drive PROCHOT# to throttle the processor

Choices: Disable, Enable.

VTX-2

To enable or disable the VTX-2 Mode support

Choices: Disable, Enable.

TM1

Enable/Disable TM1

Choices: Disable, Enable.

DTS

Enabled/Disable Digital Thermal Sensor

Choices: Disable, Enable.

CPU Power Management System Power Options

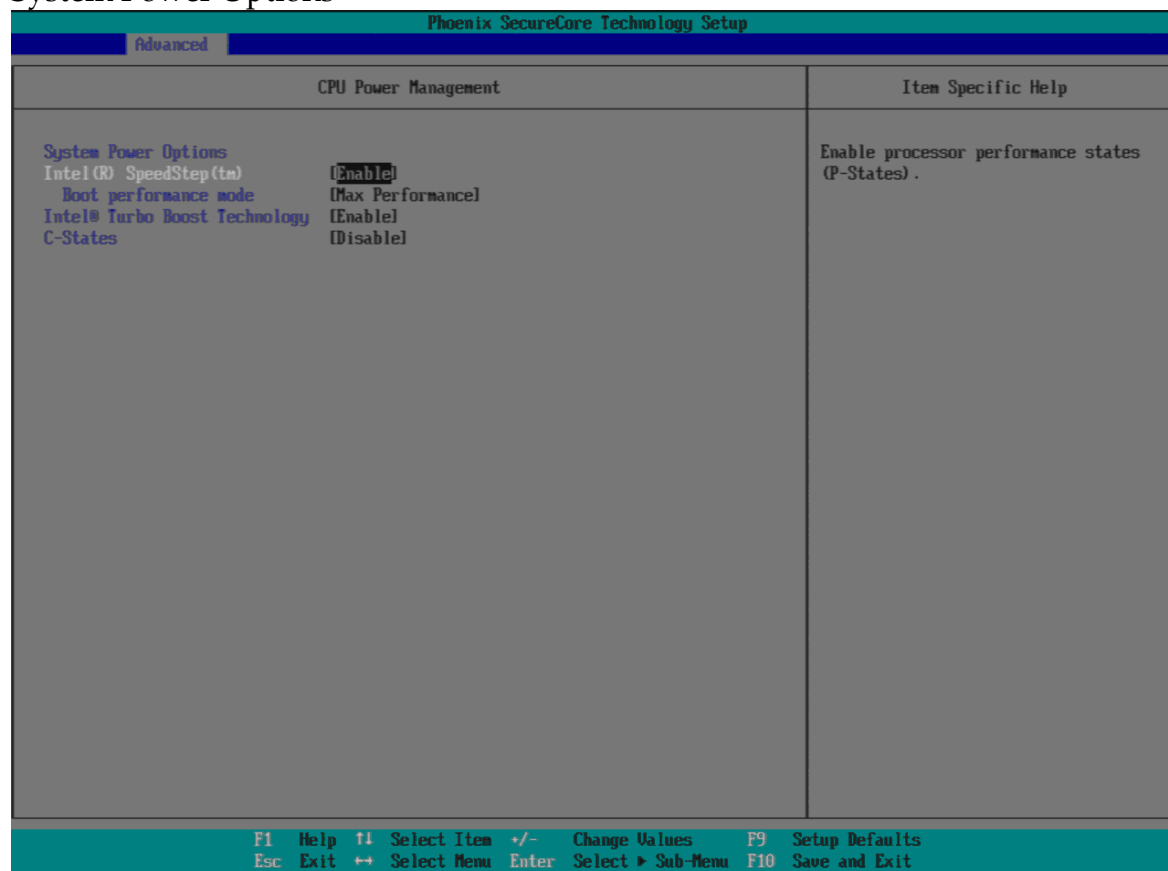

Intel® SpeedStep™

Enable processor performance status (P-Status)

Choices: Disabled, Enabled.

Boot performance mode

Select the performance state that the BIOS will set before OS handoff

Choices: Max Performance, Max Battery.

Intel® Turbo Boot Technology

Enable to automatically allow processor cores to run faster than the base operation frequency if it's operating below power, current, and temperature specification limits.

Choices: Disable, Enable.

C-States

Enable/Disable C States

Choices: Disable, Enable.

Enhanced C-States

Enable/Disable C1E, C2E and C4E. When enabled, CPU will switch to minimum speed when all cores enter C-State

Choices: Disable, Enable.

Max C State

This option controls the Max C State that the processor will support

Choices: C7, C6, C4, C1.

Uncore Configuration



GOP Configuration (Show only)

GOP Driver (Show only)

Enable GOP Driver will unload VBIOS; Disable it will load VBIOS

Choices: Enable, Disable.

IGD Configuration (Show only)

Integrated Graphic Device (Show only)

Enable: Enable Integrated Graphics Device (IGD) when selected as the Primary Video Adapter. Disable: Always disable IGD

Choices: Disable, Enable.

Primary Display (Show only)

Select which of IGD/PCI Graphics device should be Primary Display.

Choices: Auto, IGD, PCIe.

RC6 (Rander Standby) (Show only)

Check to enable render standby support

Choices: Enable, Disable.

PAVC (Show only)

Enable/Disable Protected Audio Video control.

Choices: Enable, Disable.

GTT Size (Show only)

Select the GTT Size

Choices: 1MB, 2MB.

Aperture Size (Show only)

Select the Aperture Size

Choices: 128MB, 256MB, 512MB.

DVMT Pre-Allocated (Show only)

Select DVMT 5.0 Pre-Allocated (Fixed) Graphics Memory sized used by the Internal Graphic Device

Choices: 32M, 64M, 96M, 128M, 160M, 192M, 224M, 256M, 288M, 320M, 352M, 384M,416M, 448M, 480M, 512M.

Spread Spectrum clock (Show only)

Enable clock chip Spread Spectrum feature

Choices: Disable, Enable.

IGD - LCD Control (Show only)

Force Lid States (Show only)

For test: Force to set lid status as on or off

Choices: OFF, ON.

BIA

Choices: Auto.

LCD Panel type

Choices: 640 x 480, 800 x 600, 1025 x 768, 1280 x1024, 1400 x1050, 1600 x 1200, 1360 x768, 1680 x 1050, etc.

IGD Boot Type

Select preference for Integrated Graphics Device (IGD) display interface used when system boots

Choices: Auto, VGA Port, DP, LVDS.

Panel Scaling (Show only)

Select the LCD Panel scaling option used by Internal Graphic device

Choices: Auto, Centering, Stretching.

System Component

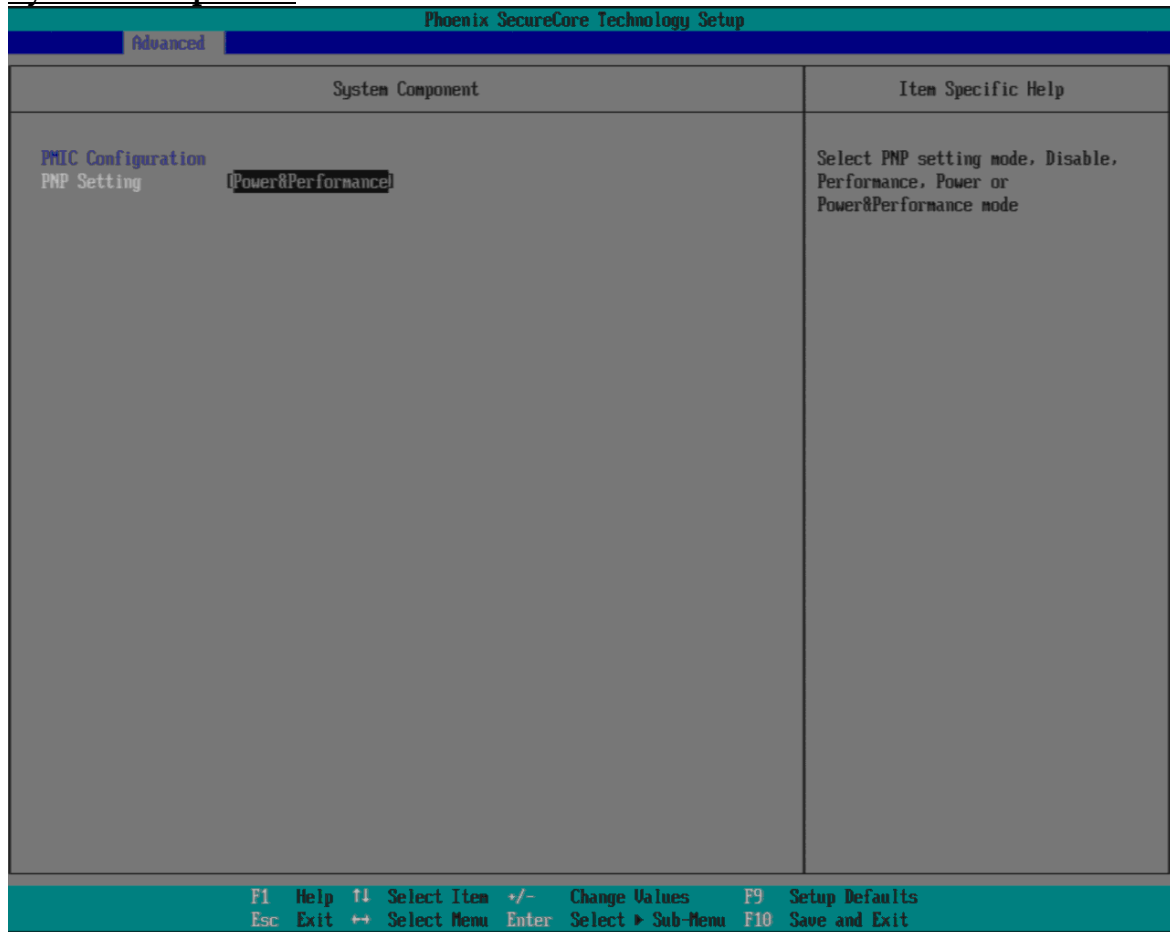

PMIC Congfiguration

PNP Setting

Select PNP setting mode, Disable, Performance, Power or Power&Performance mode.

Choices: Disable, Performance, Power, Power & Performance

South Cluster Configuration

Phoenix SecureCore Technology Setup	
Advanced	
South Cluster Configuration	Item Specific Help
<ul style="list-style-type: none"> ▶ PCI Express Configuration ▶ USB Configuration ▶ Audio Configuration ▶ SATA Drives ▶ LPSS & SCC Configuration ▶ Miscellaneous Configuration 	PCI Express Configuration Settings
F1 Help ↑↓ Select Item +/- Change Values F9 Setup Defaults Esc Exit ↔ Select Menu Enter Select ▶ Sub-Menu F10 Save and Exit	

PCI Express Configuration

PCI Express Configuration Settings

Phoenix SecureCore Technology Setup	
Advanced	
PCI Express Configuration	Item Specific Help
PCI Express Root Port 1 [Enable] PCI Express Root Port 2 [Enable] PCI Express Root Port 3 [Enable] PCI Express Root Port 4 [Enable]	Control the PCI Express Root Port.
F1 Help ↑↓ Select Item +/- Change Values F9 Setup Defaults Esc Exit ↔ Select Menu Enter Select ▶ Sub-Menu F10 Save and Exit	

PCI Express Root Port #1 - #4

Control PCI Express root port

Choices: Enable, Disable.

USB Configuration

USB Configuration settings

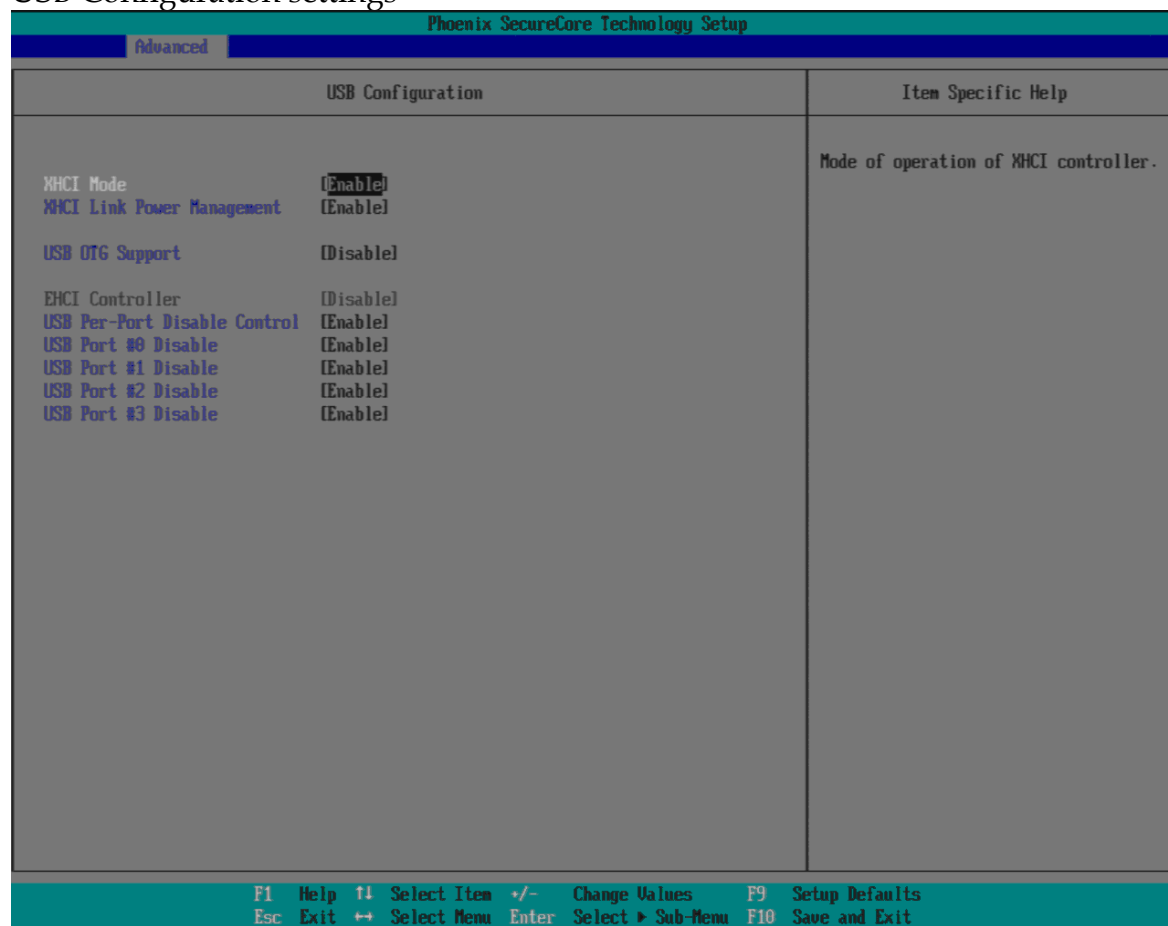

xHCI Controller

Enable/Disable xHCI Controller

Choices: Enable, Disable.

xHCI Mode

Mode of operation of xHCI controller

Choices: Smart Auto, Auto, Enable, Disable.

USB OTG Support

Enable/Disable USB OTG Support

Choices: Disable, PCI Mode, ACPI Mode.

EHCI Controller (Show only)

Control each of the USB ports (0~9) disabling

Choices: Enable, Disable.

USB Per-Port Disable Control

Control each of the USB ports (0~3) disabling

Choices: Disable, Enable.

USB Per-Port #0 ~ #3 Disable

Disable USB port

Choices: Disable, Enable.

Audio Configuration

Audio Configuration Settings

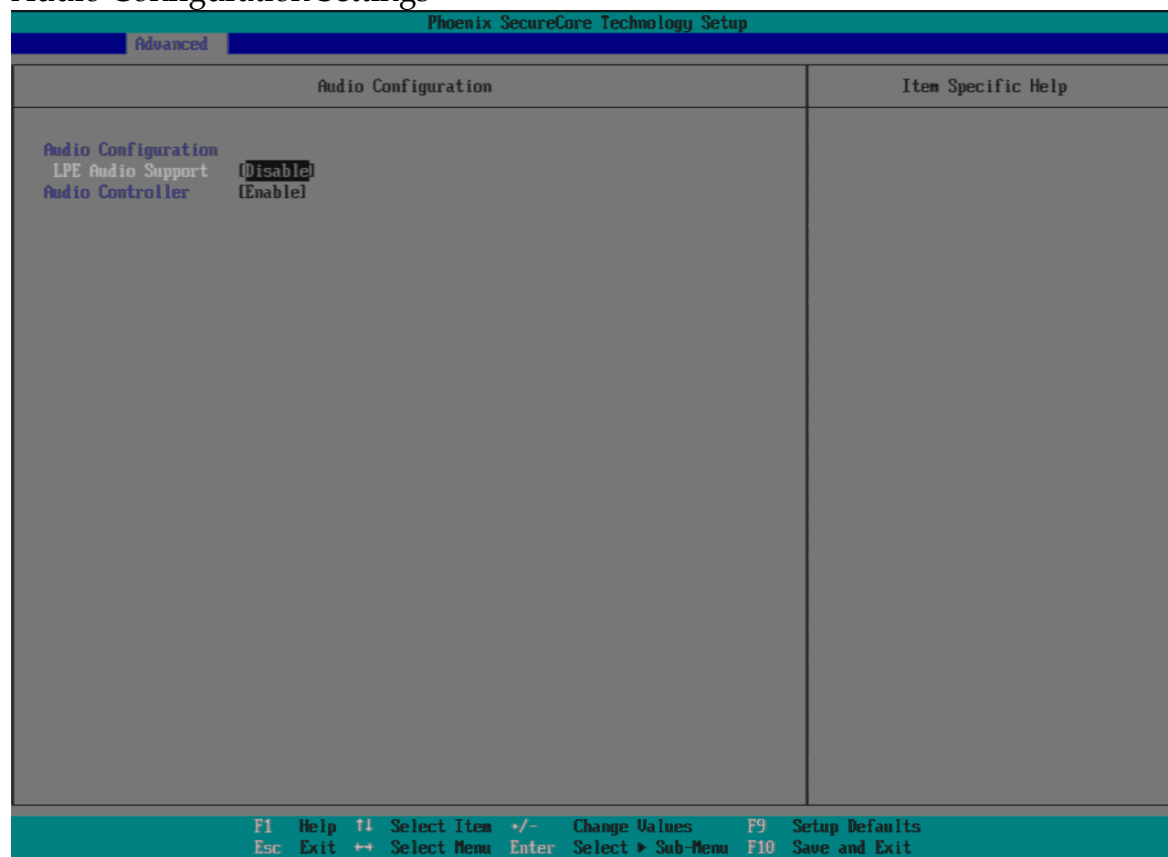

LPE Audio Support

Choices: Disable, LPE Audio PCI mode, LPE Audio ACPI mode.

Audio Controller

Control Detection of the Azalia device.

Disabled = Azalia will be unconditionally disabled.

Enabled = Azalia will be unconditionally enabled.

Choices: Disable, Enable.

SATA Drives

Press<Enter> to select the SATA Device Configuration Setup options.

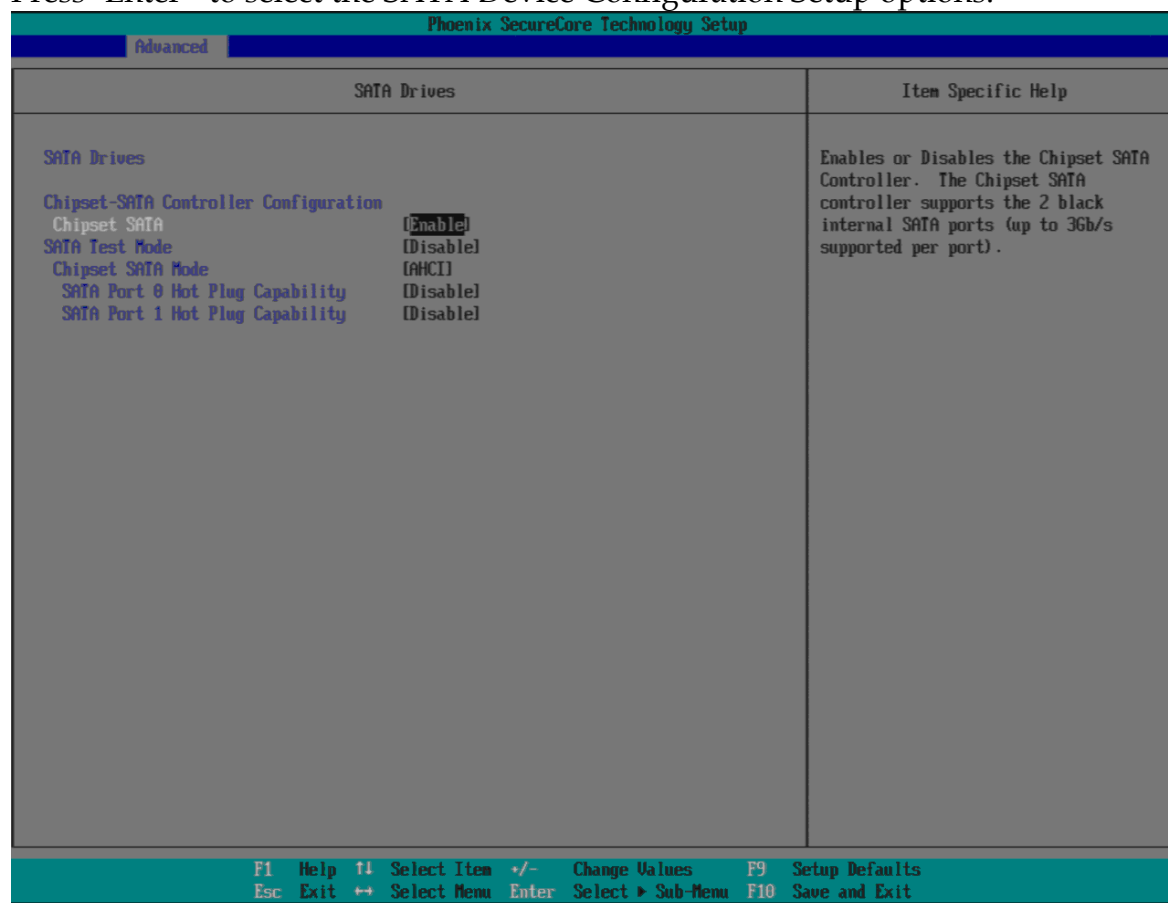

Chipset SATA

Enables or Disables the Chipset SATA Controller. The Chipset SATA controller supports the 2 black internal SATA ports (up to 3 Gb/s supported per port).

Choices: Enable, Disable.

SATA Test Mode

Test Mode Enable/Disable

Choices: Enable, Disable.

Chipset SATA Mode

IDE: Compatibility mode disables.

AHCI support: Supports advanced SATA features such as Native Command Queuing.

Warning: OS may not boot if this setting is changed after OS install.

Choices: IDE, AHCI.

Serial Port 0/1 Hot Plug Capability

If enabled, SATA port 0/1 will be reported as Hot Plug capable.

Choices: Enable, Disable.

LPSS & SCC Configuration

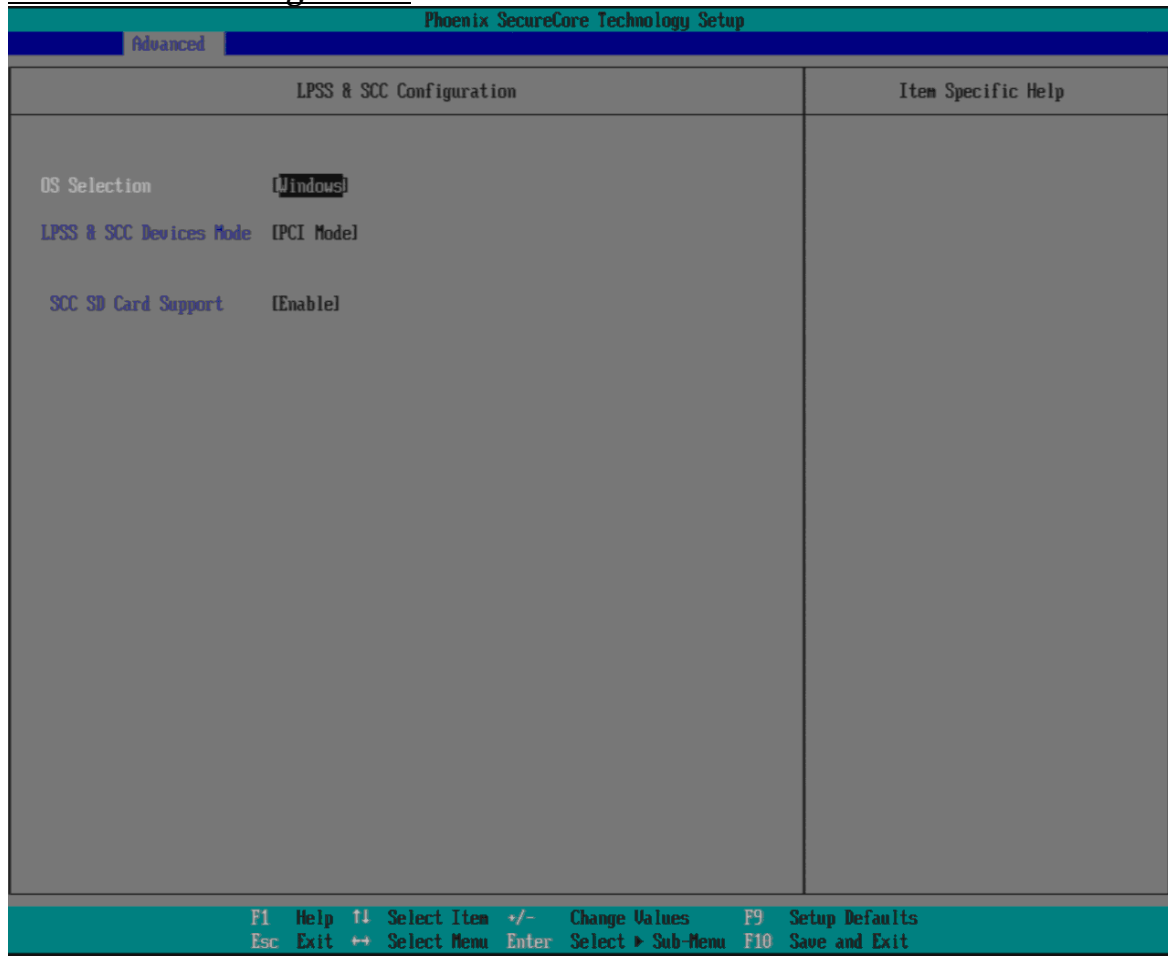

OS Selection

Choices: Windows, Android.

LPSS & SCC Devices Mode

Choices: ACPI Mode, PCI Mode.

SCC SD Card Support

Choices: Disable, Enable.

Miscellaneous Configuration

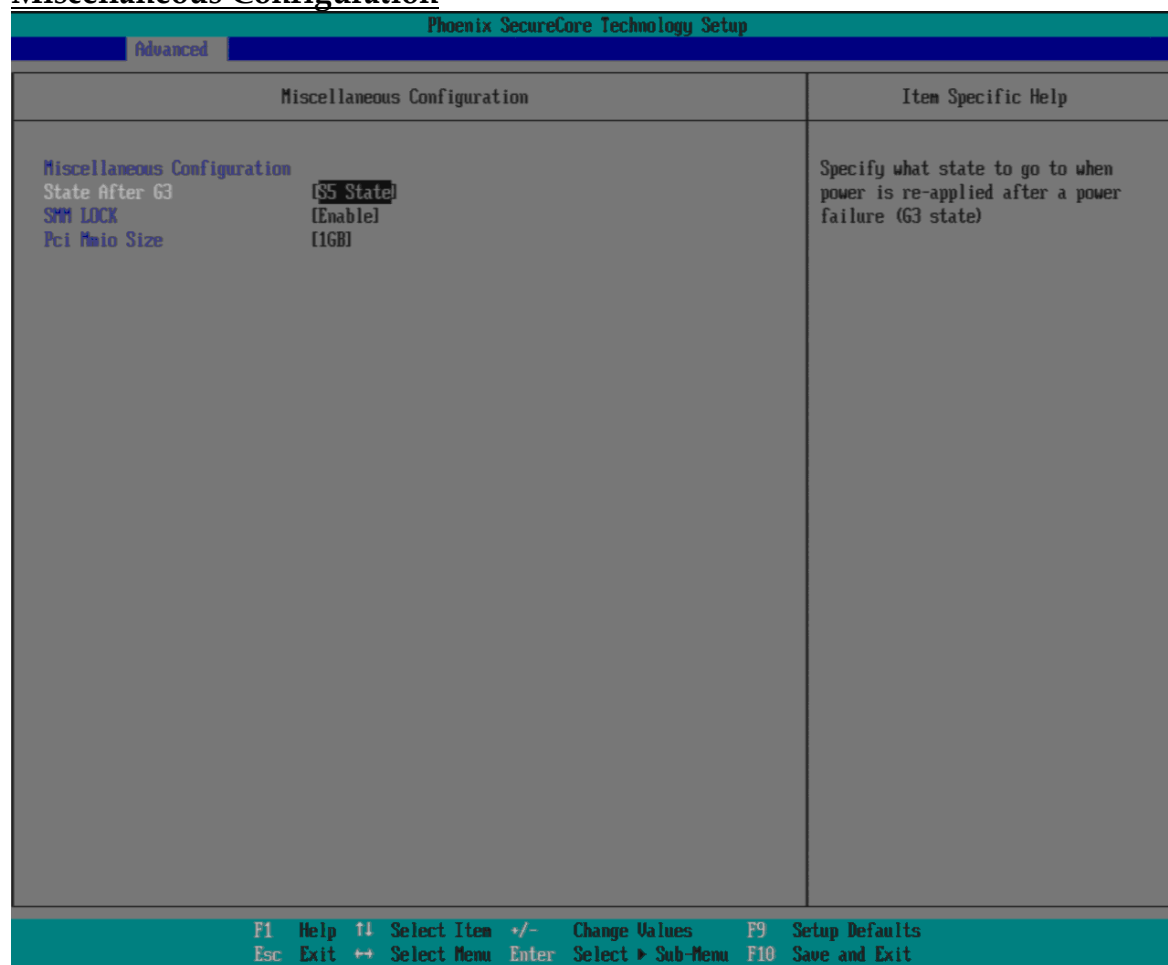

State After G3

Specify what state to go to when power is re-applied after a power failure (G3 state)
 Choices: S0 State, S5 State.

SMM LOCK

Enable/Disable SMM Lock feature. It will lock the SMRAM and unable load SMM driver any more.
 Choices: Disable, Enable.

Pci Mmio Size

Pci Mmio Size.
 Choices: 2 GB, 1.5 GB, 1.25 GB, 1GB.

4.4 Others

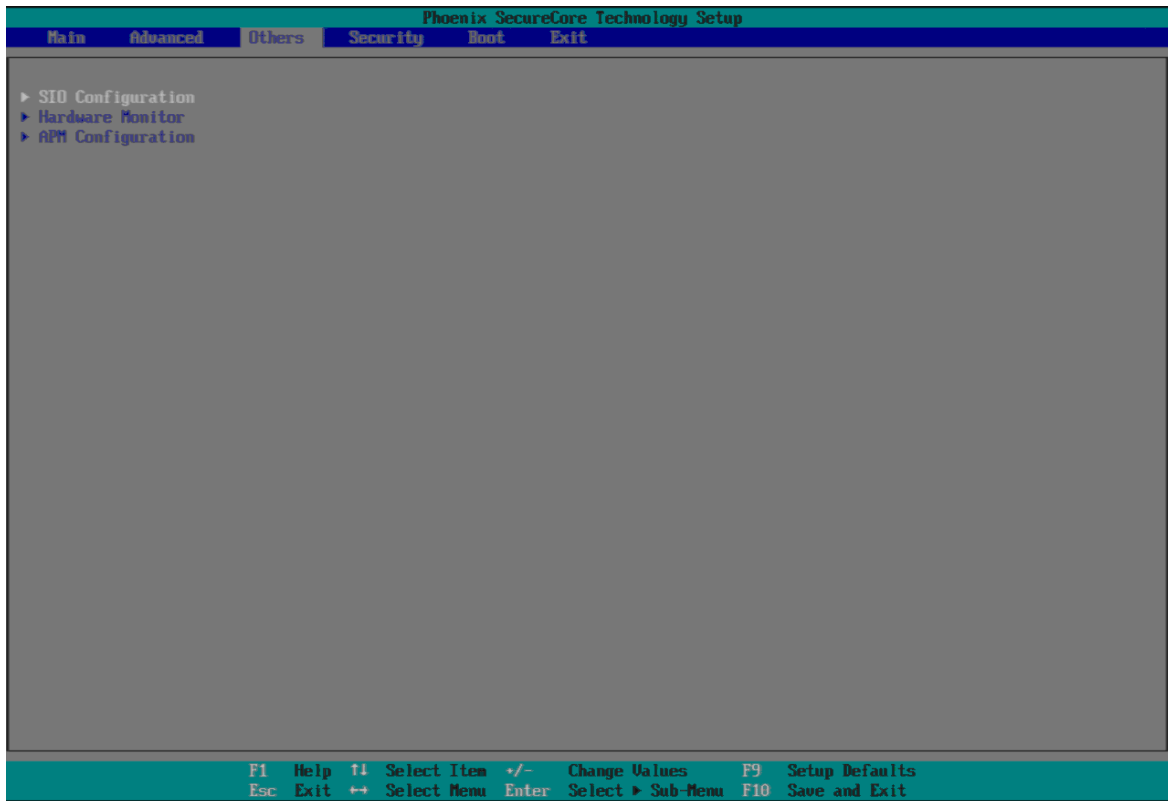

SIO Configuration

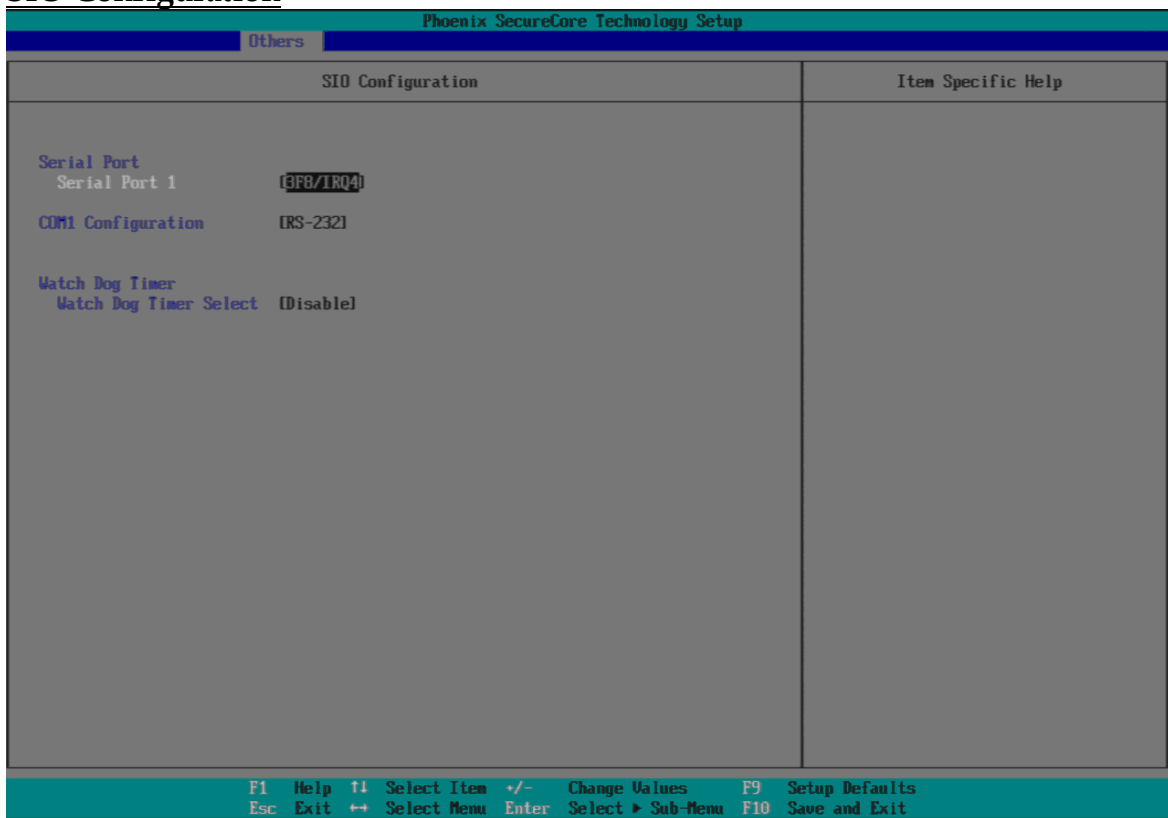

Serial Port 1

Choices: Disable 3F8/IRQ4.

COM1 Configuration

Select COM1 Configuration.

Choices: RS-232, RS-422, RS-285.

Watch Dog Timer Select

Choices: Disable, 15 secs, 30 secs, 1 min, 2 mins, 3 mins.

Hardware Monitor

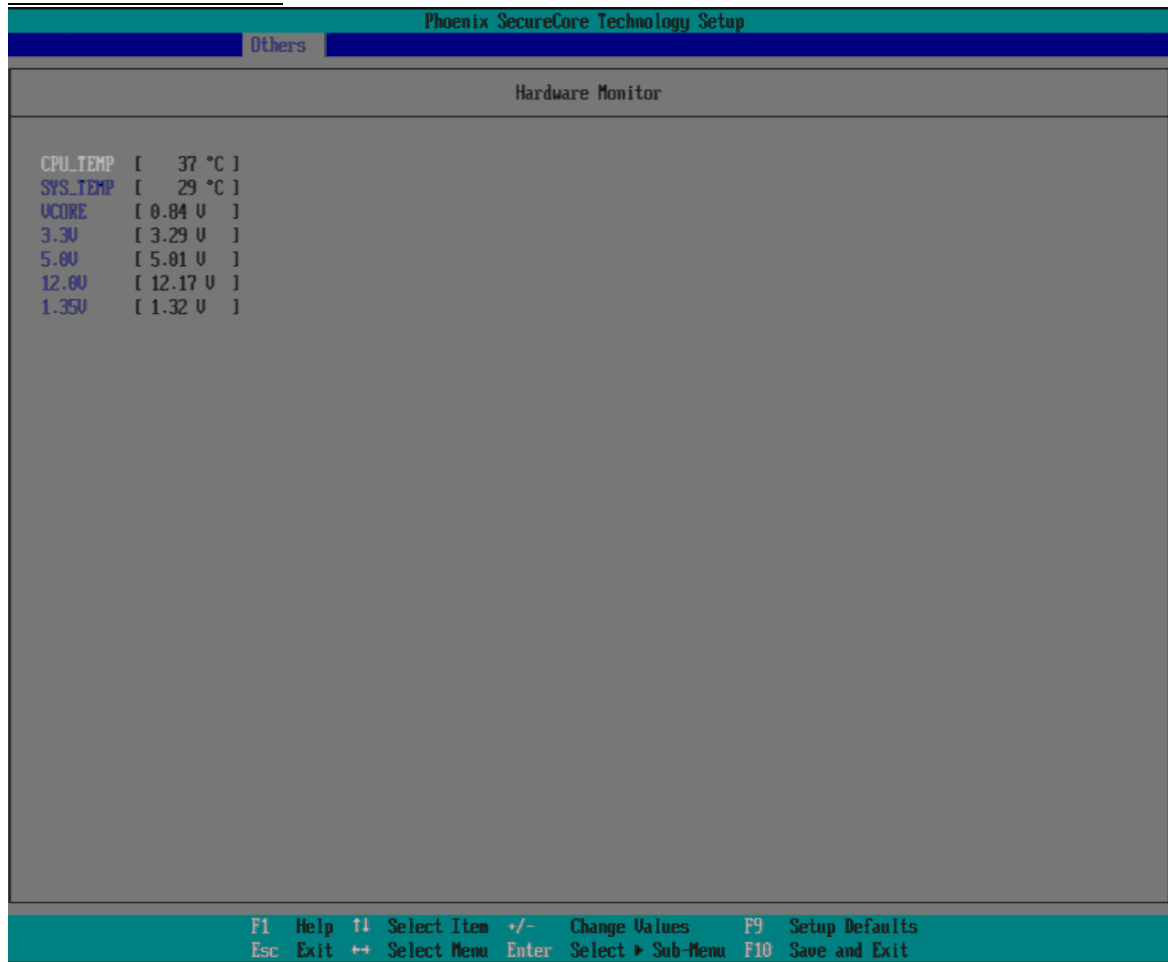

APM Configuration

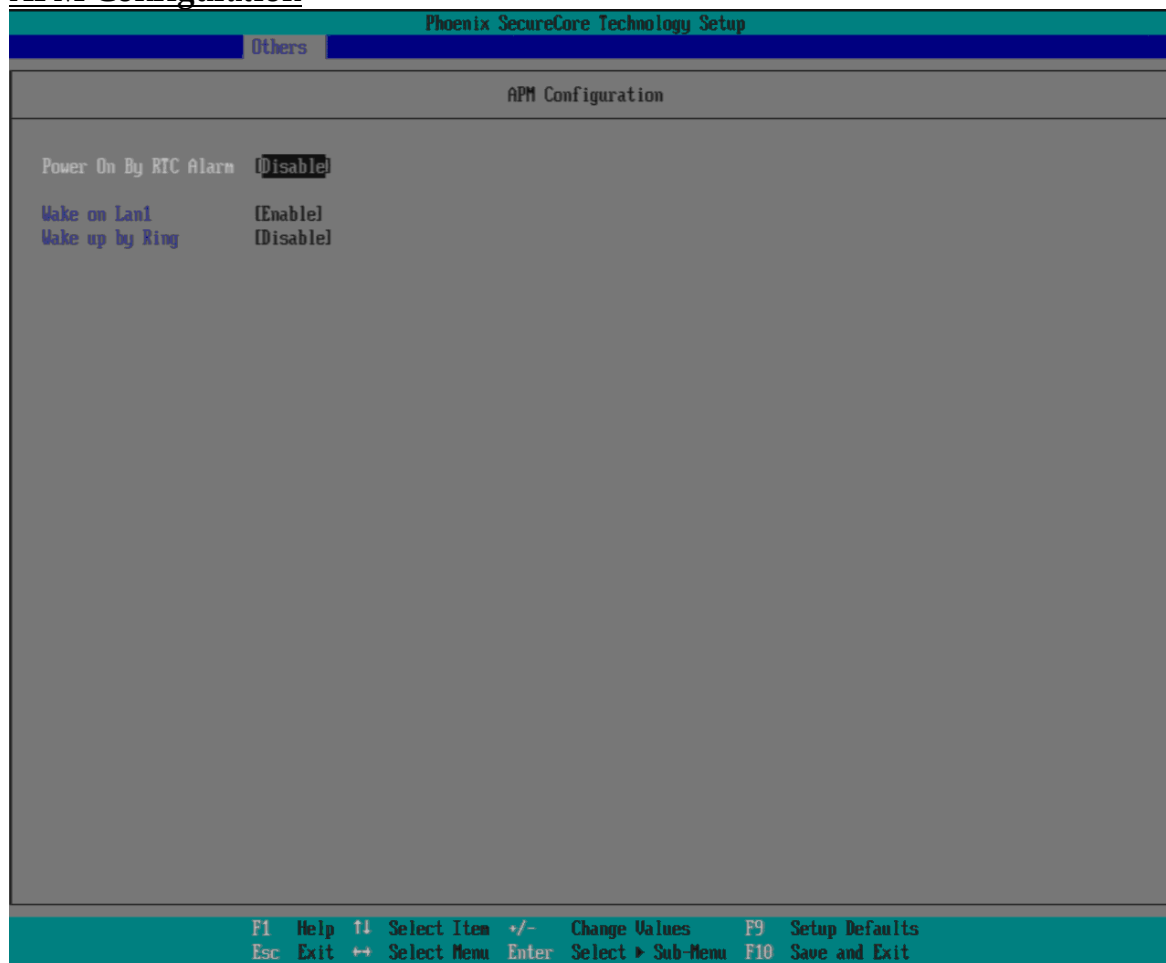

Power On By RTC Alarm

Choices: Disable, Enable.

Wake on LAN1

Choices: Disable, Enable.

Wake up by Ring

Choices: Disable, Enable.

4.5 Security

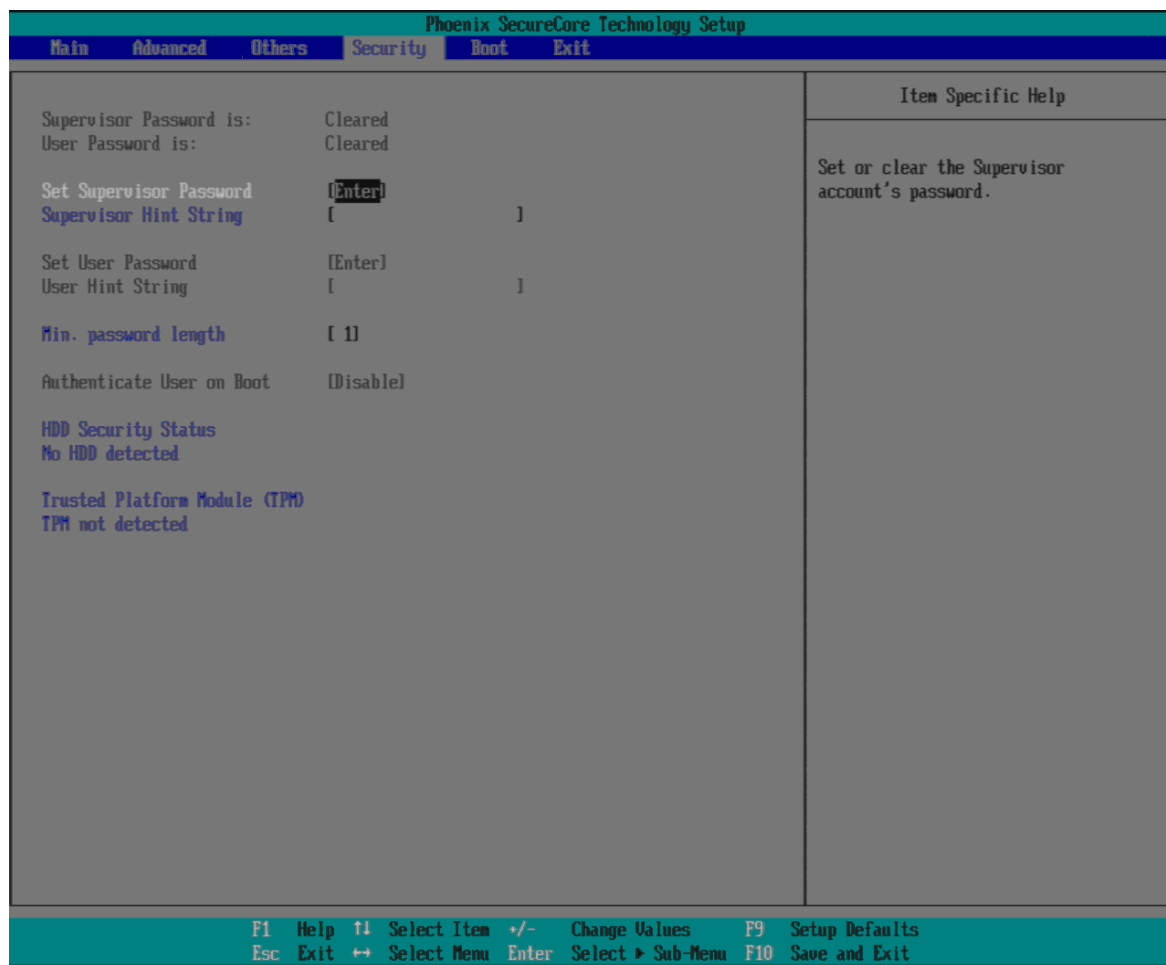

Set Supervisor Password

Set or clear the Supervisor account's password.

Supervisor Hint String

Press Enter to type Supervisor Hint String.

Set User Password (Show only)

Set or clear the User account' password.

Supervisor Hint String (Show only)

Press Enter to type User Hint String.

Min. password length

Set the minimum number of characters for password (1-20).

4.6 Boot

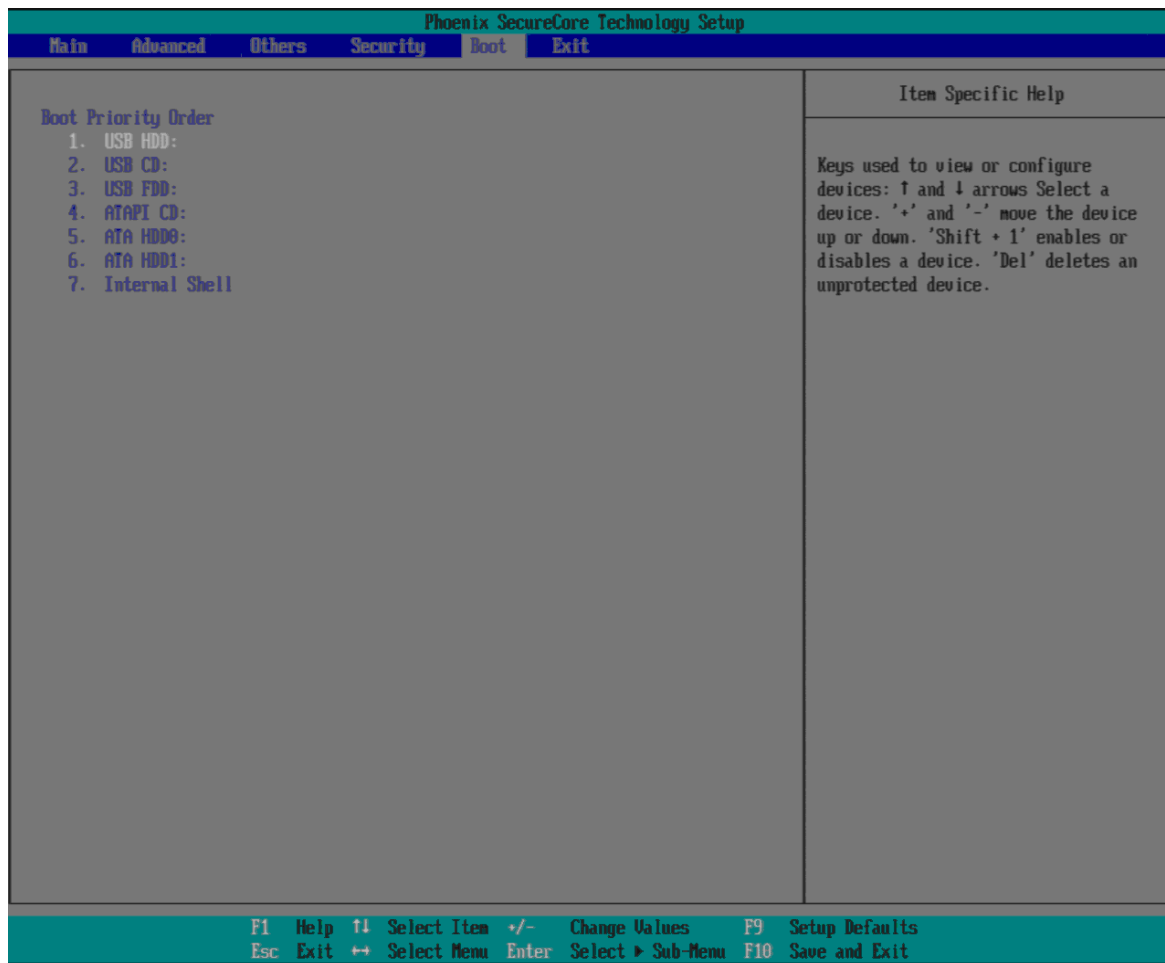

Boot Priority Order

Keys used to view or configure devices: ↑ and ↓ arrows Select a device. '+' and '-' move the device up or down. 'Shift + 1' enabled or disables a device. 'Del' deletes an unprotected device.

4.7 Exit

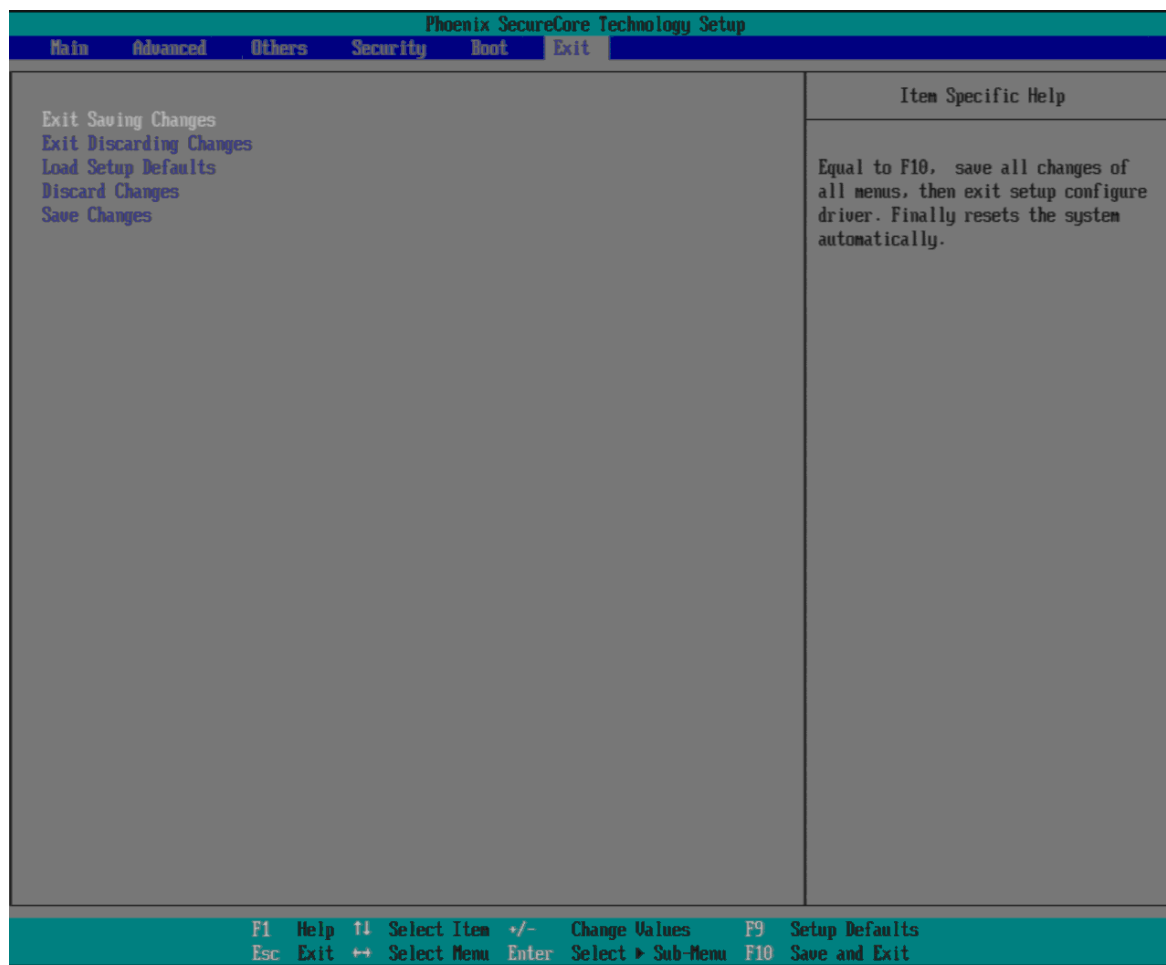

Exit Saving Changes

Equal to F10, save all changes of all menus, then exit setup configure driver. Finally resets the system automatically.

Exit Discarding Changes

Equal to ESC, never save changes, then exit setup configure driver.

Load Setup Defaults

Equal to F9. Load standard default values.

Discard Changes

Load the original value of this boot time. Not the default Setup value.

Save Changes

Save all changes of all menus, but do not reset system.

Chapter 5 Troubleshooting

This chapter provides a few useful tips to quickly get NANO-6060 running with success. As basic hardware installation has been addressed in Chapter 2, this chapter will primarily focus on system integration issues, in terms of BIOS setting, and OS diagnostics.

5.1 Hardware Quick Installation

ATX Power Setting

Unlike other Single board computer, NANO-6060 supports ATX 12V 4 Pin or Power adaptor only. Therefore, there is no other setting that really needs to be set up. However, there is ATX 4 Pin Connector - J12 & DC Jack - J1 on the NANO-6060 board.

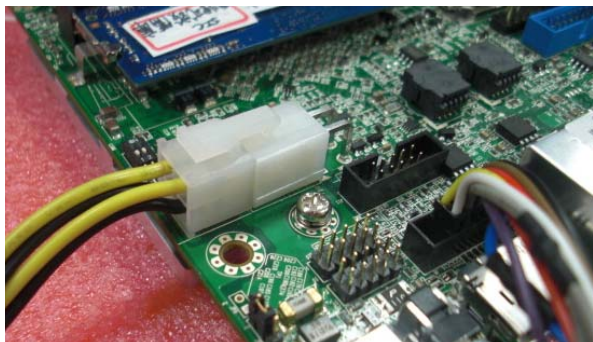

ATX 4 Pin Connector – J12

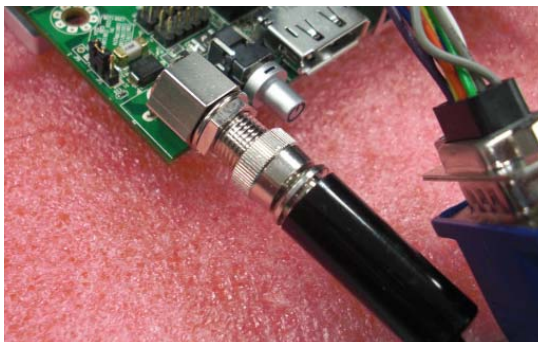

DC Jack – J1

Serial ATA

Unlike IDE bus, each Serial ATA channel can only connect to one SATA hard disk at a time; The installation of Serial ATA is simpler and easier than IDE, because SATA hard disk doesn't require setting up Master and Slave, which can reduce mistake of hardware installation.

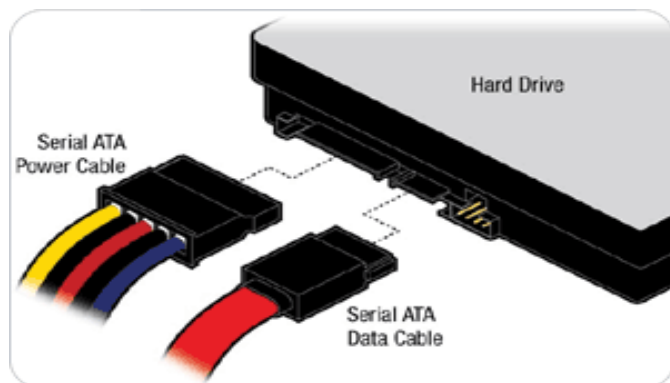

The NANO-6060 can support two SATA interface (SATAII, 3.0 Gb/s) with IDE or AHCI mode. It has two J21 & J22 SATA ports on the board.

5.2 BIOS Setting

It is assumed that users have correctly adopted modules and connected all the devices cables required before turning on ATX power. 204-pin DDR3 Memory, keyboard, mouse, SATA hard disk, VGA connector, power cable of the device, ATX accessories are good examples that deserve attention. With no assurance of properly and correctly accommodating these modules and devices, it is very possible to encounter system failures that result in malfunction of any device.

To make sure that you have a successful start with NANO-6060, it is recommended, when going with the boot-up sequence, to hit “F2” key and enter the BIOS setup menu to tune up a stable BIOS configuration so that you can wake up your system far well.

Loading the default optimal setting

When prompted with the main setup menu, please scroll down to “Load Setup Defaults”, press “Enter” and select “Yes” to load in default optimal BIOS setup. This will force your BIOS setting back to the initial factory configuration. It is recommended to do this so you can be sure the system is running with the BIOS setting that Portwell has highly endorsed. As a matter of fact, users can load the default BIOS setting any time when system appears to be unstable in boot up sequence.

5.3 FAQ

Information & Support

Question: I forget my password of system BIOS, what am I supposed to do?

Answer:

You can switch off your power supply then find the JP7/8 to set it from 1-2 short to 2-3 short and wait 5 seconds to clean your password then set it back to 1-2 short to switch on your power supply.

JP7/JP8 : CMOS Clear

JP7/8	Function
1-2 Short	Normal Operation ★
2-3 Short	Clear CMOS Contents

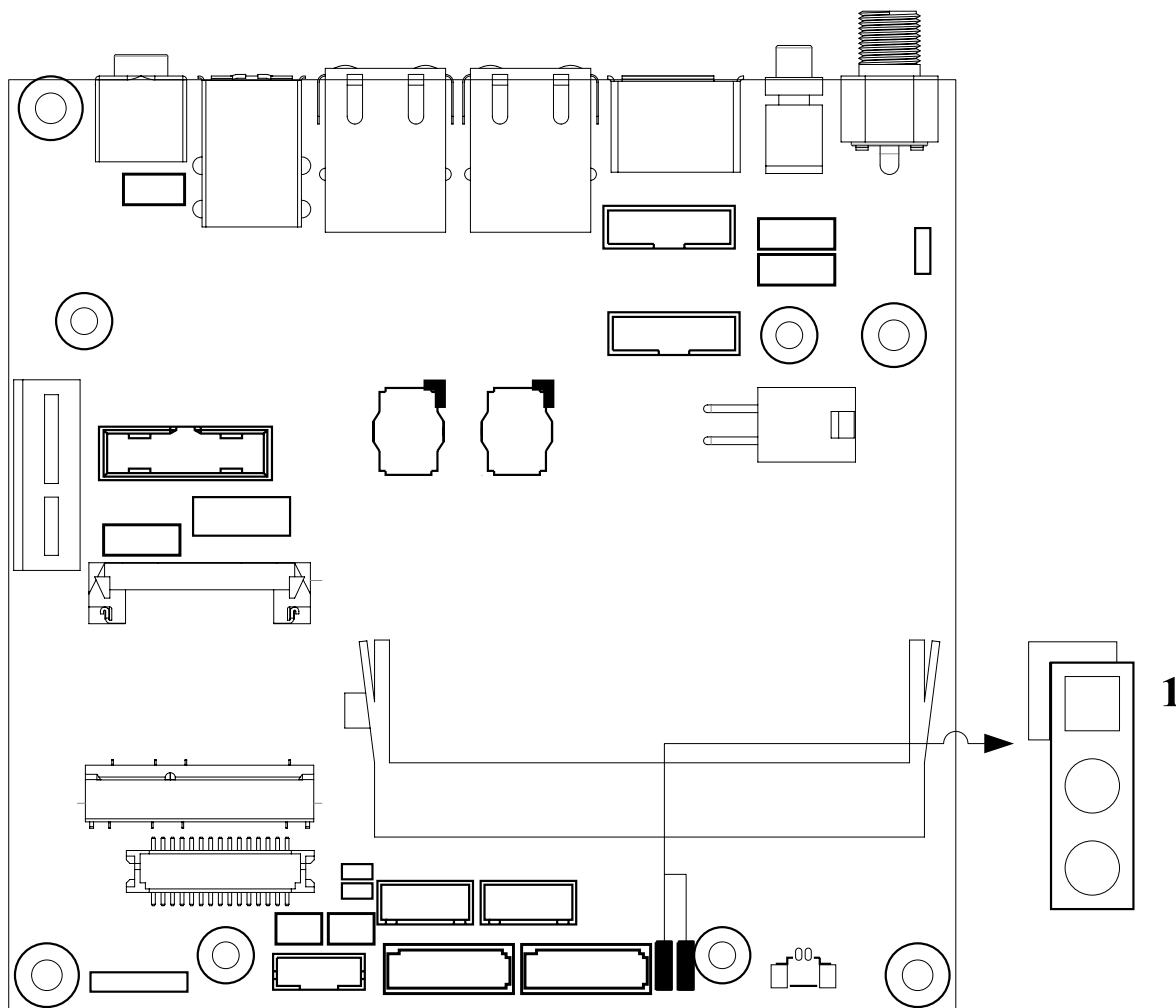

Question: How to update the BIOS file of the NANO-6060?

Answer:

- 1 Please visit web site of the Portwell Download Center as below hyperlink
http://www.portwell.com.tw/support/download_center.php
 Then you must register an account first.
<http://www.portwell.com.tw/member/newmember.php> (The E-Mail box should be an existing Company email address that you check regularly.)
- 2 Input your User name and password to log in the download center.
- 3 Select the "Search download" to input the keyword "NANO-6060".
- 4 Find the "BIOS " page to download the ROM file and flash utility.
- 5 Execute the zip file to root of the bootable USB pen drive. You can get the "Shell Flash 32.efi", "temp.bin", "Update.nsh" three files.
- 6 Insert your USB pen drive in USB port of the NANO-6060 board and power-on.

- 7 Boot to EFI-Shell mode then input the “fs0:” command to switch to the root of the USB pen drive.

```

FI Shell version 2.31 [4660.22136]
urrent running mode 1.1.2
evice mapping table
fs0      :Removable HardDisk - Alias hd22a0c0b blk0
          Acpi (PNP0A03.0) /Pci (1410) /Usb (0.0) /Usb (2.0) /Unit (0) /HD (Part1.Sig019F1C9D)
fs1      :Removable BlockDevice - Alias f22a0c0 blk1
          Acpi (PNP0A03.0) /Pci (1410) /Usb (0.0) /Usb (2.0) /Unit (1)
blk0     :Removable HardDisk - Alias hd22a0c0b fs0
          Acpi (PNP0A03.0) /Pci (1410) /Usb (0.0) /Usb (2.0) /Unit (0) /HD (Part1.Sig019F1C9D)
blk1     :Removable BlockDevice - Alias f22a0c0 fs1
          Acpi (PNP0A03.0) /Pci (1410) /Usb (0.0) /Usb (2.0) /Unit (1)
blk2     :Removable BlockDevice - Alias (null)
          Acpi (PNP0A03.0) /Pci (1410) /Usb (0.0) /Usb (2.0) /Unit (0)

ress ESC in 3 seconds to skip startup.nsh, any other key to continue.
hell> fs0:_
    
```

- 8 Type the “update” command to start flash BIOS processes

```

FI Shell version 2.31 [4660.22136]
urrent running mode 1.1.2
evice mapping table
fs0      :Removable HardDisk - Alias hd22a0c0b blk0
          Acpi (PNP0A03.0) /Pci (1410) /Usb (0.0) /Usb (2.0) /Unit (0) /HD (Part1.Sig019F1C9D)
fs1      :Removable BlockDevice - Alias f22a0c0 blk1
          Acpi (PNP0A03.0) /Pci (1410) /Usb (0.0) /Usb (2.0) /Unit (1)
blk0     :Removable HardDisk - Alias hd22a0c0b fs0
          Acpi (PNP0A03.0) /Pci (1410) /Usb (0.0) /Usb (2.0) /Unit (0) /HD (Part1.Sig019F1C9D)
blk1     :Removable BlockDevice - Alias f22a0c0 fs1
          Acpi (PNP0A03.0) /Pci (1410) /Usb (0.0) /Usb (2.0) /Unit (1)
blk2     :Removable BlockDevice - Alias (null)
          Acpi (PNP0A03.0) /Pci (1410) /Usb (0.0) /Usb (2.0) /Unit (0)

ress ESC in 3 seconds to skip startup.nsh, any other key to continue.
hell> fs0:
s0:\> update_
    
```

- 9 When it finished all update processes, it will reboot in 5 seconds automatically

```

s0:\> cd update_32

s0:\update_32> update
update> fpt -y -f temp.bin

intel (R) Flash Programming Tool. Version: 1.1.0.1073
Copyright (c) 2007 - 2013, Intel Corporation. All rights reserved.

Platform: Bay Trail
piLoadDevicesFile (fparts.txt) ...
Reading HSFSTS register... Flash Descriptor: Valid

--- Flash Devices Found ---
MK25U6435F   ID:0xC22537   Size: 8192KB (65536Kb)

DR Region does not exist.

Reading Flash [0x7F5C40] 8151KB of 8192KB - 100% complete.
Erasing Flash Block [0x003000] - 100% complete.
Programming Flash [0x003000] 4KB of 4KB - 100% complete.
Erasing Flash Block [0x005000] - 100% complete.
Programming Flash [0x005000] 4KB of 4KB - 100% complete.
Erasing Flash Block [0x00A000] - 100% complete.
Programming Flash [0x00A000] 8KB of 8KB - 100% complete.
Erasing Flash Block [0x654000] - 100% complete.
Programming Flash [0x651E80] 1671KB of 1680KB - 100% complete.
Erasing Flash Block [0x72C000] - 100% complete.
Programming Flash [0x72C000] 4KB of 4KB - 100% complete.
Erasing Flash Block [0x732000] - 100% complete.
Programming Flash [0x731FC0] 19KB of 20KB - 100% complete.
Erasing Flash Block [0x741000] - 100% complete.
Programming Flash [0x740F40] 39KB of 40KB - 100% complete.
Erasing Flash Block [0x743000] - 100% complete.
Programming Flash [0x743000] 4KB of 4KB - 100% complete.
Erasing Flash Block [0x75A000] - 100% complete.
Programming Flash [0x75A000] 4KB of 4KB - 100% complete.
Erasing Flash Block [0x776000] - 100% complete.
Programming Flash [0x776000] 4KB of 4KB - 100% complete.
Erasing Flash Block [0x778000] - 100% complete.
Programming Flash [0x778000] 4KB of 4KB - 100% complete.
Erasing Flash Block [0x780000] - 100% complete.
Programming Flash [0x780000] 4KB of 4KB - 100% complete.
Erasing Flash Block [0x7E9000] - 100% complete.
Programming Flash [0x7E9000] 4KB of 4KB - 100% complete.
Erasing Flash Block [0x7EC000] - 100% complete.
Programming Flash [0x7EC000] 8KB of 8KB - 100% complete.
Erasing Flash Block [0x7EF000] - 100% complete.
Programming Flash [0x7EF000] 8KB of 8KB - 100% complete.
Verifying Flash [0x7F5C40] 8151KB of 8192KB - 100% complete.
ESULI: The data is identical.

PT Operation Passed

s0:\update_32> _
    
```



10 Please press the “F2” key to BIOS setup menu to select “Load Setup Defaults” and then select “Exit Saving Changes” option to finish all BIOS flash processes

Question: How to install USB 3.0 Windows 7 driver of the NANO-6060?

Answer:

Because of the NANO-6060 is Bay Trail platform, USB 3.0 driver need to use the other method to install USB 3.0 driver on windows 7, but windows 8 OS doesn't.

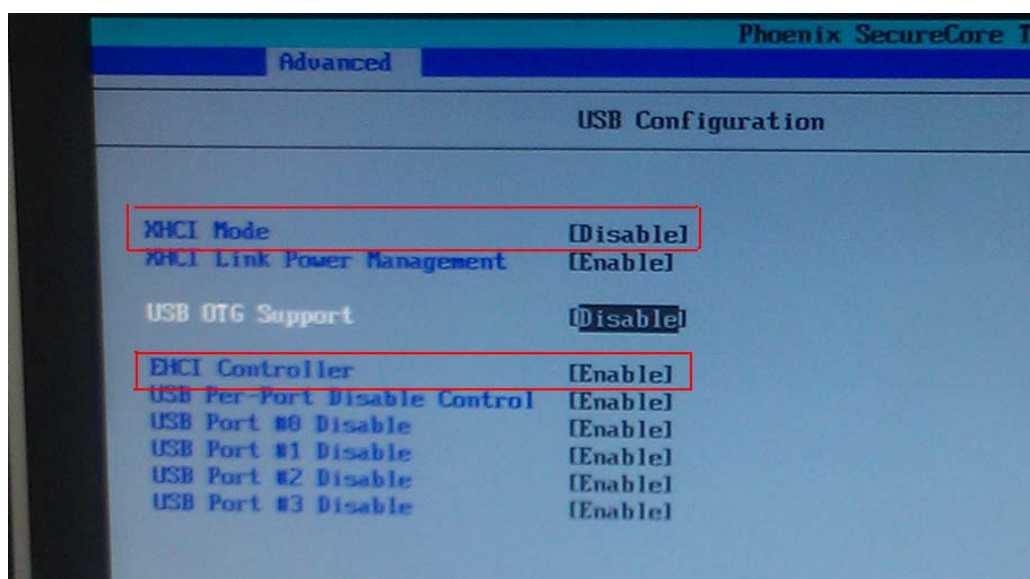
Step1. You must disable the XHCI mode and enable the EHCI Controller from BIOS setup menu then install windows



Step2. After complete the Windows 7 installation then adjust the BIOS setting of XHCI mode to [Smart Auto] and keep EHCI Controller as [Enable].

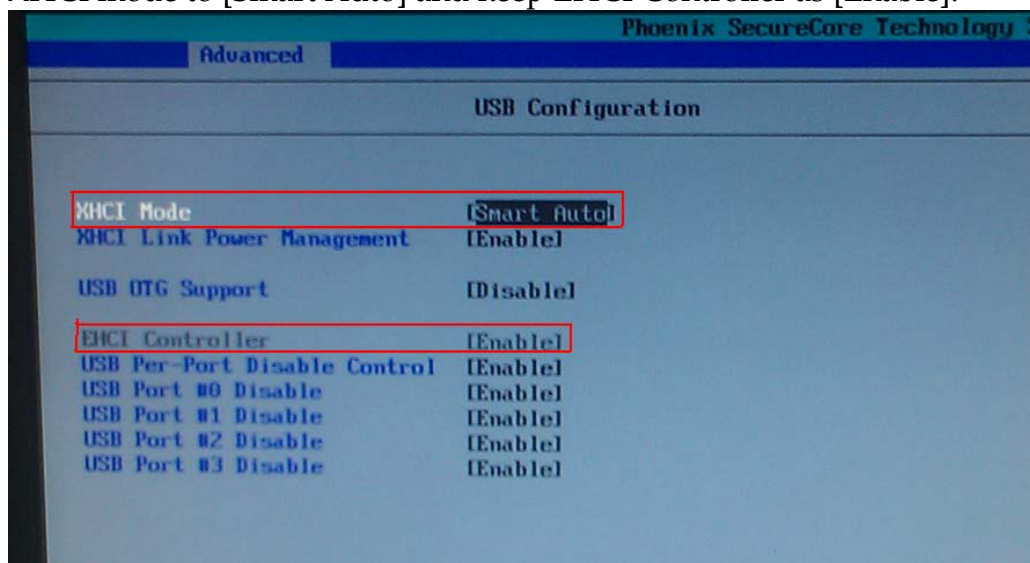

Step3. Boot to the windows 7 then install the USB 3.0 driver.

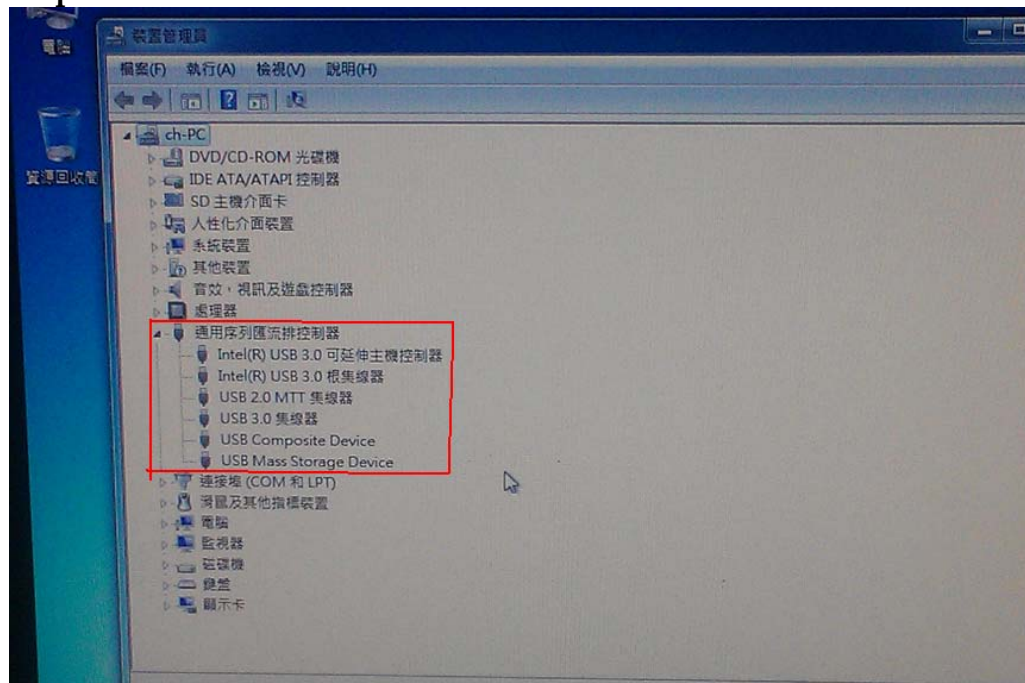

Step4. You need to adjust the BIOS setting of XHCI mode to [Enable] and EHCI Controller to [Disable], and finally then boot to OS.

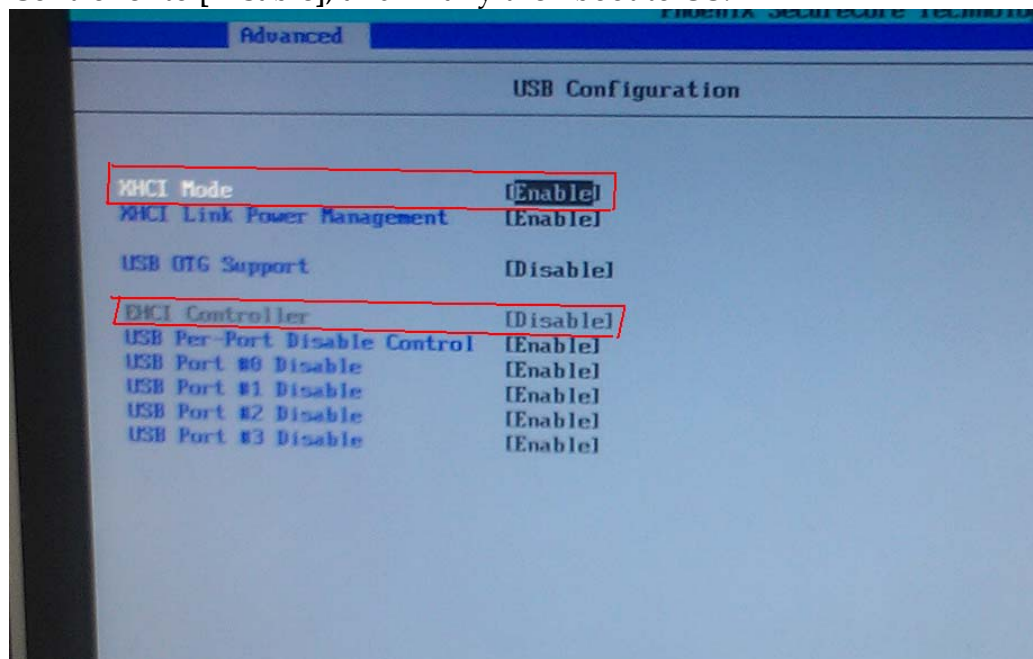

Following the above 4 steps, USB 3.0 can work well on Windows 7 OS.

Note:

Please visit our Download Center to get the Catalog, User manual, BIOS, and driver files.

http://www.portwell.com.tw/support/download_center.php

If you have other additional technical information or request which is not covered in

this manual, please fill in the technical request form as below hyperlink.
http://www.portwell.com.tw/support/problem_report.php

We will do our best to provide a suggestion or solution for you.

Thank you.