

# OPERATOR'S MANUAL

# 5696-1

INCLUDING: SPECIFICATIONS, SERVICE KITS, PLACING INTO SERVICE, TROUBLESHOOTING  
INCLUDE MANUALS: 569X Basic Pump (pn 97999-1036), 636077-X "Z" Swivel (pn 97999-42), 636103 Control Handle  
(pn 97999-115), S-633 GENERAL INFORMATION (pn 97999-625)

RELEASED: 2-4-03  
REVISED:  
(REV. A)

## 5696-1 GREASE PUMP SYSTEM

### SPECIFICATIONS

Model Series	5696-1
Type	Air Operated Grease Pump, Portable 35 lb. Bucket System
Ratio	50:1
Air Motor Diameter	3" (7.62 cm)
Stroke (Double acting)	3" (7.62 cm)
Air Inlet (female)	1/4 - 18 N.P.T.F.
Material Outlet (female)	3/8 - 18 N.P.T.F.
Pump Construction	Carbon Steel
Dimensional Data	29" (737 mm)
Weight	30.7 lbs (12 kgs)

### PERFORMANCE

Air Inlet Pressure Range	0 - 150 p.s.i. (0 - 10.3 bar)
Fluid Pressure Range	0 - 7500 p.s.i. (0 - 517 bar)
Displacement In <sup>3</sup> Per Cycle	0.875
Volume / Cycle	0.48 oz. (14.33 ml)
Cycles Per Lb.	30
Maximum Delivery / Minute	7.5 lbs (3.4 kg)
Noise Level @ 100 p.s.i.	85 db(A)

### SERVICE KITS

- **637386 Pump Rebuild Kit.** Includes the necessary soft parts for normal service of the entire pump.
- Use only genuine IR® replacement parts to assure compatible pressure rating and longest service life.

### GENERAL DESCRIPTION

5696-1 Portable Grease Pump System. Includes the 50:1 grease pump, handle, follower plate and drum cover plus material hose and gun.

### IMPORTANT

This is one of five documents which support the pump system. Replacement copies of these forms are available upon request.

- 5696-1 Model Operator's Manual (pn 97999-1037)
- 569X Model Operator's Manual (pn 97999-1036)
- 636077-X "Z" Swivel (pn 97999-42)
- 636103 Control Handle (pn 97999-115)
- S-633 General Information Lubrication Piston Pumps (pn 97999-625)

### OPERATING AND SAFETY PRECAUTIONS

**⚠ WARNING** READ THE GENERAL INFORMATION MANUAL INCLUDED FOR OPERATING AND SAFETY PRECAUTIONS AND OTHER IMPORTANT INFORMATION.

### PUMP DATA

#### MODEL 5696-1

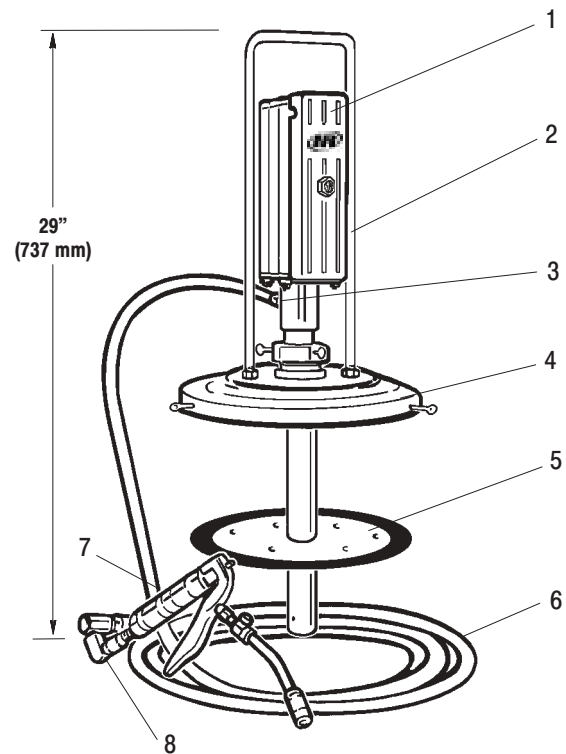

Figure 1

### MAJOR COMPONENTS

Item	Description (size in inches)	(Qty)	Part No.
1	Basic 50:1 Grease Pump	(1)	5696
2	Handle	(1)	94334
3	Adapter (1/8 - 27 x 3/8 - 18 N.P.T.F.)	(1)	76493
4	Cover & Hardware	(1)	94420
5	Follower Plate	(1)	640095-2-B
6	10' Material Hose	(1)	624201-10
7	Grease Gun	(1)	636103
8	Z - Swivel	(1)	636077



---

---

## PLACING INTO SERVICE

---

**⚠ WARNING** **EXCESSIVE INLET PRESSURE.** Can cause explosion resulting in severe injury or death. Do not exceed maximum operating pressure of 7500 p.s.i. (517.2 bar) at 150 p.s.i. (10.3 bar) inlet air pressure. Do not run pump without using a regulator to limit air supply pressure to the pump.

$$\text{PUMP RATIO} \times \text{INLET PRESSURE TO PUMP MOTOR} = \text{MAXIMUM PUMP FLUID PRESSURE}$$

Pump ratio is an expression of the relationship between the pump motor area and the lower pump end area. EXAMPLE: When 150 p.s.i. (10.3 bar) inlet pressure is supplied to the motor of a 50:1 ratio pump it will develop a maximum of 7500 p.s.i. (517.2 bar) fluid pressure (at no flow) – as the fluid control is opened, the flow rate will increase as the motor cycle rate increases to keep up with the demand.

**⚠ WARNING** **EXCESSIVE MATERIAL PRESSURE.** Can cause equipment failure resulting in severe injury or property damage. Do not exceed the maximum material pressure handling capability of any component in the system.

**Thermal expansion hazard.** This can occur when the fluid in the material line is exposed to elevated temperatures. Example: Material line located in a non-insulated roof area can warm due to sunlight. Install a pressure relief valve in the pumping system if this condition could exist.

### AIR AND LUBRICATION REQUIREMENTS

Filtered air will help extend the life of the pump, allowing the pump to operate more efficiently and yield longer service life to moving parts and mechanisms.

- Use an air line filter to provide good quality clean and dry air, install it up stream from the air regulator.
- Use an air regulator on the air supply to control the pump cycle rate, install the regulator as close as possible to the pump.
- In most installations lubrication is not required. If the pump needs to have lubrication, install an air line lubricator between the pump and the air regulator and supply it with a good grade of non-detergent oil or other lubricant compatible with Nitrile seals. Set at a rate not to exceed one drop per minute.

---

## INSTALLATION

---

Assemble components included in the package as shown in figure 1. NOTE: In rigid plumbing applications, use flexible material and air supply hoses when attaching the pump to prevent damage by vibration.

1. Thread the pump bung adapter into the pump cover, insert the pump into the bung and then secure with the thumb screws provided.
2. Install the handle and secure with the four nuts provided with the cover.
3. Install the outlet adapter, material hose, swivel and gun.
4. Lay the follower on top of a full bucket of grease, feed the lower pump end into the follower and secure the cover with the thumb screws.
5. Attach the coupler to the air supply hose and the connector to the pump air inlet adapter.
6. Connect the material hose to the pump outlet. Tighten all fittings. Use caution not to damage threads.

---

## OPERATION

---

### START-UP

1. Turn the air regulator to “0” pressure setting. Connect the air hose.
2. Prime the pump by **cycling slowly**, raising the pressure to 20 - 30 p.s.i. (1.4 - 2.1 bar). Cycle the pump until the test grease and any trapped air has been purged from the system.
3. Close the dispensing device. Allow the pump to build line pressure and stall. Check for any leaks and re-torque fittings if needed. Adjust air pressure upward as required for the application.

**NOTICE:** If the pump does not prime soon after initial start-up, establish what the problem is to prevent unnecessary damage to the pump plunger.

### SHUTDOWN

- Disconnect the air supply from the pump if it is to be inactive for a few hours. Open the dispensing device to relieve line pressure.

---

## SERVICE

---

Refer to the basic pump manual for service instructions which also covers disassembly and reassembly for installation of the rebuild kit.

---

## TROUBLE SHOOTING

---

**If the pump does not cycle or will not deliver material.**

- Be certain to check for non-pump problems including kinked, restrictive or plugged inlet / outlet hose or dispensing device. Depressurize the pump system and clean out any obstructions in the inlet / outlet material lines.
- Check all seals, including track gaskets.

