



SAMSUNG

Touchscreen monitor User Manual

S24C770

The color and the appearance may differ depending on the product, and the specifications are subject to change without prior notice to improve the performance.

BN46-00341A-03

Table of contents

Before Using the Product

Copyright	4
Securing the Installation Space	5
Precautions for storage	5
Safety Precautions	5
Symbols	5
Cleaning	6
Electricity and Safety	6
Installation	7
Operation	9
Correct posture to use the product	12
Tilting the product	12

Preparations

Checking the Contents	13
Removing the Packaging	13
Checking the Components	14
Parts	15
Front Buttons	15
Reverse Side	16
Adjusting the Product Tilt	17
Anti-theft Lock	18

Using MagicTune Touch

About MagicTune Touch	19
Requirements	19
Installing/Uninstalling MagicTune Touch (Windows)	20
Installation	20
Uninstallation	20
Installing MagicTune Touch (Mac)	20
Installation	20

Using a touchscreen monitor

Touchscreen monitor	21
Requirements	21
Read below before using the product	21
Connecting the touchscreen monitor	22
Connecting to a PC	22
Connecting to a laptop or tablet PC	22
Configuring the touchscreen monitor settings	23
Accessing the calibration menu	23
Calibration	25
Configuring the touchscreen monitor settings from a Mac	27
Installing Touch Base	27
Controlling the screen	28
Basic touch functions	28

Notes	29
-------	----

Connecting and Using a Source Device

Before Connecting	30
Pre-connection Checkpoints	30
Connection Using an HDMI Cable	31
Connecting to a PC	31
Connecting to a Video Device	31
Connection Using an HDMI-DVI Cable	32
Connecting to a PC	32
Connecting to a Video Device	32
Connecting to an Audio System	33
Connecting the Power	33
Changing the Resolution	34
Changing the Resolution on Windows 7	34
Changing the Resolution on Windows 8	34

OSD menu

Exiting from the menu	35
Adjusting the brightness	35
Changing the screen size	36
In PC mode	36

Table of contents

In AV mode	36
Configuring the HDMI black level	37
Enabling/disabling the off timer	37
Enabling PC or AV mode	38
Adjusting the volume	38

Troubleshooting Guide

Requirements Before Contacting Samsung Customer Service Center	39
Testing the Product	39
Checking the Resolution and Frequency	39
Check the followings.	40
Q & A	43

Specifications

General	44
PowerSaver	46
Preset Timing Modes	47

Appendix

Contact SAMSUNG WORLD WIDE	49
Responsibility for the Pay Service(Cost to Customers)	57
Not a product defect	57
A Product damage caused by customer's fault	57
Others	57
Correct Disposal	58
Correct Disposal of This Product (Waste Electrical & Electronic Equipment)	58
Correct disposal of batteries in this product	58
License	59
Terminology	60

Chapter 01

Before Using the Product

Copyright

The contents of this manual are subject to change without notice to improve quality.

© 2013 Samsung Electronics

Samsung Electronics owns the copyright for this manual.

Use or reproduction of this manual in parts or entirety without the authorization of Samsung Electronics is prohibited.

Microsoft, Windows are registered trademarks of Microsoft Corporation.

VESA, DPM and DDC are registered trademarks of the Video Electronics Standards Association.

Ownership of all other trademarks is attributed to their due owner.

- An administration fee may be charged if either
 - (a) an engineer is called out at your request and there is no defect in the product (i.e. where you have failed to read this user manual).
 - (b) you bring the unit to a repair center and there is no defect in the product (i.e. where you have failed to read this user manual).
- The amount of such administration charge will be advised to you before any work or home visit is carried out.

Securing the Installation Space

Ensure some space around the product for ventilation. An internal temperature rise may cause fire and damage the product. Be sure to allow the amount of space as shown below or greater when installing the product.

— The exterior may differ depending on the product.

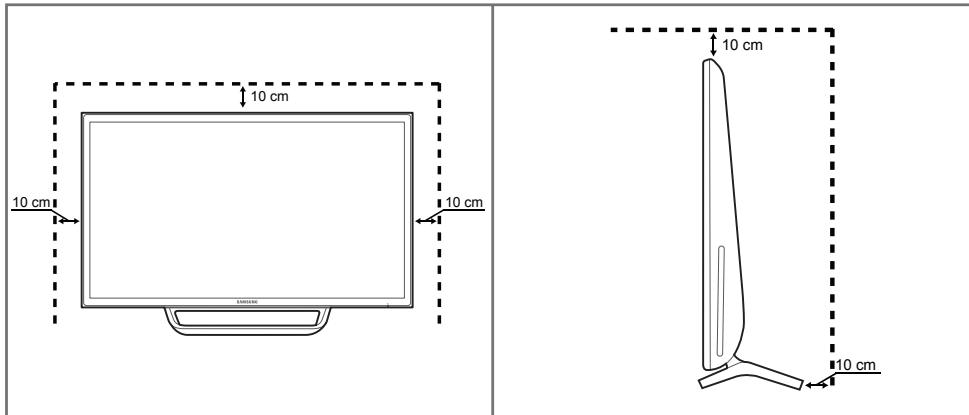

Precautions for storage

High-glossy models can develop white stains on the surface if an ultrasonic wave humidifier is used nearby.

— Contact your nearest Samsung Customer Service Center if you want to clean the inside of the product (Service fee will be charged.)

Safety Precautions

Caution

RISK OF ELECTRIC SHOCK DO NOT OPEN

Caution : TO REDUCE THE RISK OF ELECTRIC SHOCK, DO NOT REMOVE COVER. (OR BACK)

THERE ARE NO USER SERVICEABLE PARTS INSIDE.

REFER ALL SERVICING TO QUALIFIED PERSONNEL.



This symbol indicates that high voltage is present inside.

It is dangerous to make any kind of contact with any internal part of this product.



This symbol alerts you that important literature concerning operation and maintenance has been included with this product.

Symbols

Warning

A serious or fatal injury may result if instructions are not followed.

Caution

Personal injury or damage to properties may result if instructions are not followed.



Activities marked by this symbol are prohibited.



Instructions marked by this symbol must be followed.

Cleaning

- Exercise care when cleaning as the panel and exterior of advanced LCDs are easily scratched.
- Take the following steps when cleaning.
- The following images are for reference only. Real-life situations may differ from what is shown in the images.

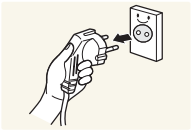

1 Power off the product and computer.

2 Disconnect the power cord from the product.

- Hold the power cable by the plug and do not touch the cable with wet hands. Otherwise, an electric shock may result.

3 To clean the product screen, spray LCD cleaning solution onto a soft cloth. Wipe stains using the cloth.

- Cleaning solution or a cloth that contains abrasives may damage the touch screen.

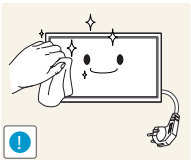

- Do not spray cleaning solution directly onto the touch screen. The cleaning solution may soak into the touch screen.

4 Wet a soft and dry cloth in water and wring thoroughly to clean the exterior of the product.

5 Connect the power cord to the product when cleaning is finished.

6 Power on the product and computer.

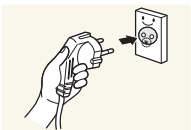
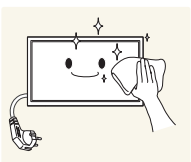

Electricity and Safety

- The following images are for reference only. Real-life situations may differ from what is shown in the images.

Warning

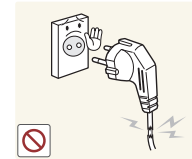

- Do not use a damaged power cord or plug, or a loose power socket.
- An electric shock or fire may result.

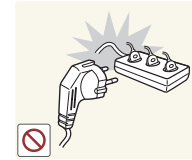

- Do not use multiple products with a single power socket.
- Overheated power sockets may cause a fire.



- Do not touch the power plug with wet hands. Otherwise, an electric shock may result.

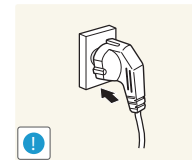

- Insert the power plug all the way in so it is not loose.
- An unsecure connection may cause a fire.

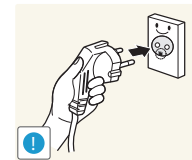

- Connect the power plug to a grounded power socket (type 1 insulated devices only).
- An electric shock or injury may result.

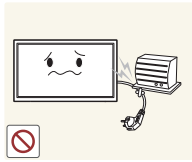

Do not bend or pull the power cord with force. Be careful not to leave the power cord under a heavy object.

- Damage to the cord may result in a fire or electric shock.



Do not place the power cord or product near heat sources.

- A fire or electric shock may result.

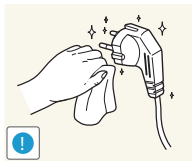

Clean any dust around the pins of the power plug or the power socket with a dry cloth.

- A fire may result.

Caution

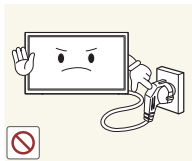

Do not disconnect the power cord while the product is being used.

- The product may become damaged by an electric shock.

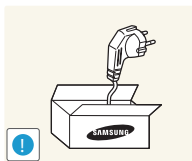

Only use the power cord provided with your product by Samsung. Do not use the power cord with other products.

- A fire or electric shock may result.

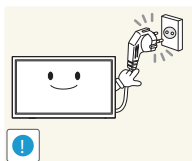

Keep the power socket where the power cord is connected unobstructed.

- The power cord must be disconnected to cut off power to the product when an issue occurs.

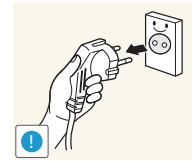

Hold the plug when disconnecting the power cord from the power socket.

- An electric shock or fire may result.

Installation

Warning



DO NOT PLACE CANDLES, INSECT REPELLANTS OR CIGARETTES ON TOP OF THE PRODUCT. DO NOT INSTALL THE PRODUCT NEAR HEAT SOURCES.

- A fire may result.

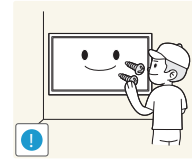

Have a technician install the wall-mount hanger.

- Installation by an unqualified person can result in an injury.
- Only use approved cabinets.



Do not install the product in poorly ventilated spaces such as a bookcase or closet.

- An increased internal temperature may cause a fire.

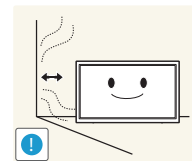

Install the product at least 10cm away from the wall to allow ventilation.

- An increased internal temperature may cause a fire.

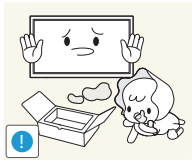

Keep the plastic packaging out of the reach of children.

- Children may suffocate.



Do not install the product on an unstable or vibrating surface (insecure shelf, sloped surface, etc.)

- The product may fall and become damaged and/or cause an injury.
- Using the product in an area with excess vibration may damage the product or cause a fire.

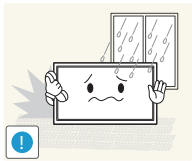

Do not install the product in a vehicle or a place exposed to dust, moisture (water drips, etc.), oil, or smoke.

- A fire or electric shock may result.

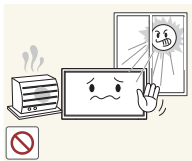

Do not expose the product to direct sunlight, heat, or a hot object such as a stove.

- The product lifespan may be reduced or a fire may result.



Do not install the product within the reach of young children.

- The product may fall and injure children.
- As the front is heavy, install the product on a flat and stable surface.



Edible oil, such as soybean oil, can damage or deform the product. Do not install the product in a kitchen or near a kitchen counter.

Caution

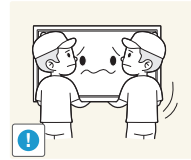

Do not drop the product while moving.

- Product failure or personal injury may result.

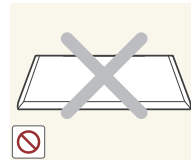

Do not set down the product on its front.

- The screen may become damaged.

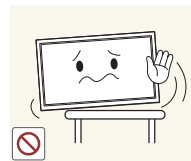

When installing the product on a cabinet or shelf, make sure that the bottom edge of the front of the product is not protruding.

- The product may fall and become damaged and/or cause an injury.
- Install the product only on cabinets or shelves of the right size.

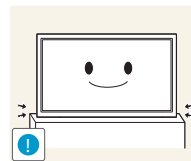

Set down the product gently.

- Product failure or personal injury may result.



Installing the product in an unusual place (a place exposed to a lot of fine particles, chemical substances or extreme temperatures, or an airport or train station where the product should operate continuously for an extended period of time) may seriously affect its performance.

- Be sure to consult Samsung Customer Service Center if you want to install the product at such a place.

Operation

Warning



There is a high voltage inside the product. Never disassemble, repair or modify the product yourself.

- A fire or electric shock may result.
- Contact Samsung Customer Service Center for repairs.

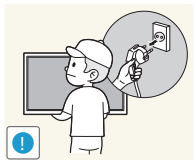

Before moving the product, turn off the power switch and disconnect the power cable and all other connected cables.

- Damage to the cord may result in a fire or electric shock.

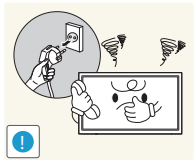

If the product generates abnormal sounds, a burning smell or smoke, disconnect the power cord immediately and contact Samsung Customer Service Center.

- An electric shock or fire may result.



Do not let children hang from the product or climb on top of it.

- Children may become injured or seriously harmed.

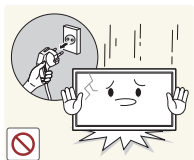

If the product is dropped or the outer case is damaged, turn off the power switch and disconnect the power cord. Then contact Samsung Customer Service Center.

- Continued use can result in a fire or electric shock.

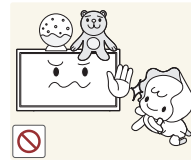

Do not leave heavy objects or items that children like (toys, sweets, etc.) on top of the product.

- The product or heavy objects may fall as children try to reach for the toys or sweets resulting in a serious injury.

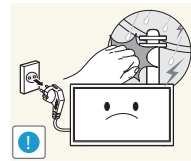

During a lightning or thunderstorm, power off the product and remove the power cable.

- A fire or electric shock may result.

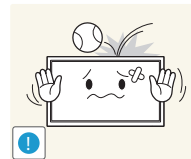

Do not drop objects on the product or apply impact.

- A fire or electric shock may result.

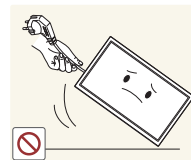

Do not move the product by pulling the power cord or any cable.

- Product failure, an electric shock or fire may result from a damaged cable.

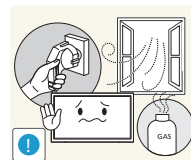

If a gas leakage is found, do not touch the product or power plug. Also, ventilate the area immediately.

- Sparks can cause an explosion or fire.

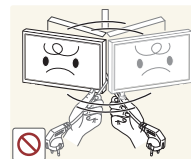

Do not lift or move the product by pulling the power cord or any cable.

- Product failure, an electric shock or fire may result from a damaged cable.

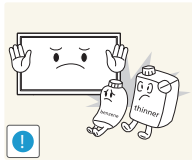

Do not use or keep combustible spray or an inflammable substance near the product.

- An explosion or fire may result.

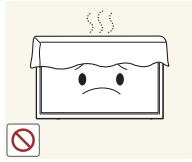

Ensure the vents are not blocked by tablecloths or curtains.

- An increased internal temperature may cause a fire.

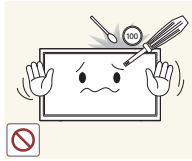

Do not insert metallic objects (chopsticks, coins, hairpins, etc) or objects that burn easily (paper, matches, etc) into the product (via the vent or input/output ports, etc).

- Be sure to power off the product and disconnect the power cord when water or other foreign substances have entered the product. Then contact Samsung Customer Service Center.
- Product failure, an electric shock or fire may result.

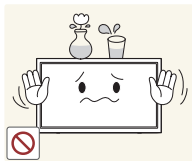

Do not place objects containing liquid (vases, pots, bottles, etc) or metallic objects on top of the product.

- Be sure to power off the product and disconnect the power cord when water or other foreign substances have entered the product. Then contact Samsung Customer Service Center.
- Product failure, an electric shock or fire may result.

Caution

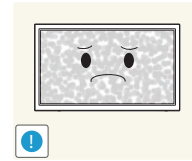

Leaving the screen fixed on a stationary image for an extended period of time may cause afterimage burn-in or defective pixels.

- Activate power-saving mode or a moving-picture screen saver if you will not be using the product for an extended period of time.

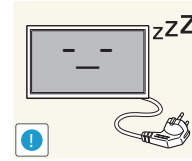

Disconnect the power cord from the power socket if you do not plan on using the product for an extended period of time (vacation, etc).

- Dust accumulation combined with heat can cause a fire, electric shock or electric leakage.

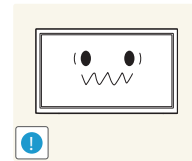

Use the product at the recommended resolution and frequency.

- Your eyesight may deteriorate.

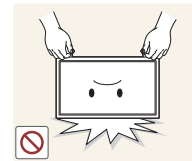

Do not hold the product upside-down or move it by holding the stand.

- The product may fall and become damaged or cause an injury.

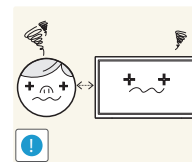

Looking at the screen too close for an extended period of time can deteriorate your eyesight.



Do not use humidifiers or stoves around the product.

- A fire or electric shock may result.

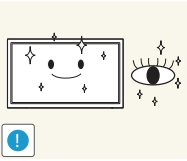

Rest your eyes for more than 5 minutes for every 1 hour of product use.

- Eye fatigue will be relieved.



Do not touch the screen when the product has been turned on for an extended period of time as it will become hot.

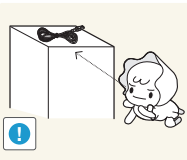

Store small accessories out of the reach of children.

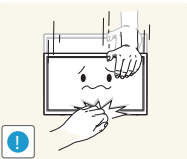

Exercise caution when adjusting the product angle or stand height.

- Your hand or finger may get stuck and injured.
- Tilting the product at an excessive angle may cause the product to fall and an injury may result.



Do not place heavy objects on the product.

- Product failure or personal injury may result.



When using headphones or earphones, do not turn the volume too high.

- Having the sound too loud may damage your hearing.

Correct posture to use the product



Use the product in the correct posture as follows:

- Straighten your back.
- Allow a distance of 45 to 50cm between your eye and the screen, and look slightly downward at the screen. Keep your eyes directly in front of the screen.
- Adjust the angle so light does not reflect on the screen.
- Keep your forearms perpendicular to your upper arms and level with the back of your hands.
- Keep your elbows at about a right angle.
- Adjust the height of the product so you can keep your knees bent at 90 degrees or more, your heels attached to the floor, and your arms lower than your heart.

Tilting the product

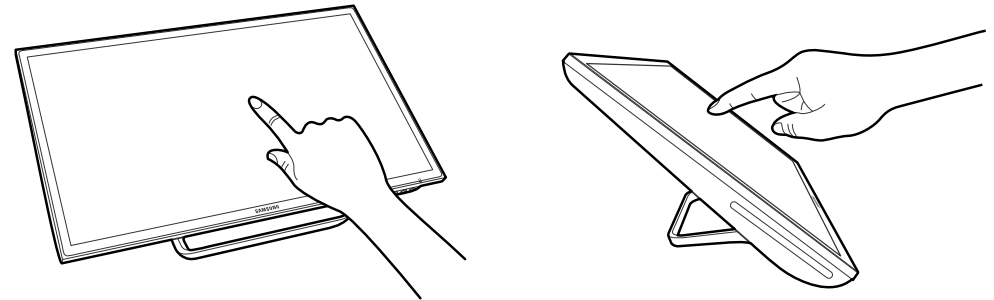

The product can be tilted according to the user's preference. At some angles, light may reflect due to an external light source. It is recommended to use the product upright to minimize reflection. The touched location may not be accurate and is dependent on the user's eye level.

- An accurate touch position can be obtained if your eye is level with the touched location on the screen.

Chapter 02

Preparations

Checking the Contents

Removing the Packaging

— The following images are for reference only. Real-life situations may differ from what is shown in the images.

- 1 Open the packaging box. Be careful not to damage the product when you open the packaging with a sharp instrument.

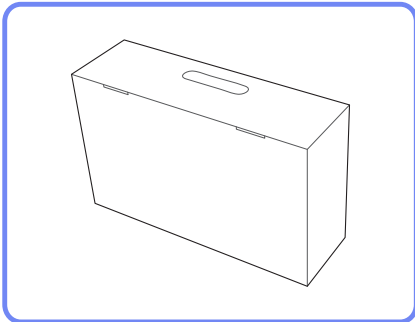

- 2 Remove the styrofoam from the product.

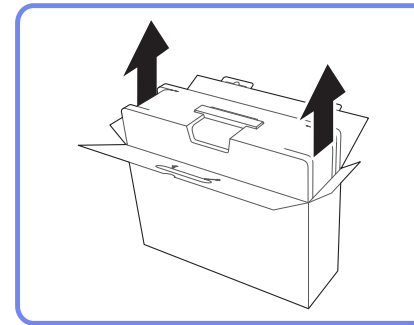

- 3 Check the components and remove the styrofoam and plastic bag.

— This image is for reference only.

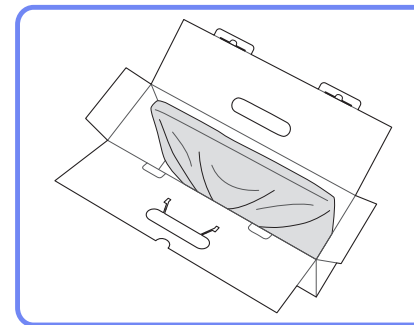

- 4 Store the box in a dry area so that it can be used when moving the product in the future.

Checking the Components

- Contact the vendor where you purchased the product if any components are missing.
- The appearance of the components and items sold separately may differ from the image shown.
- Components may vary depending on the country.

Components

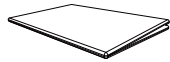

Quick setup guide



Warranty card
(Not available in some locations)

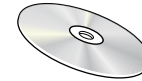

User manual



Power cord ([P.33](#))

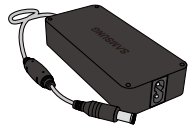

DC power adapter

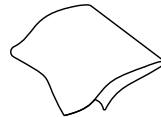

Cleaning cloth

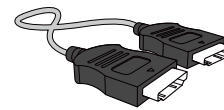

HDMI cable ([P.31](#))

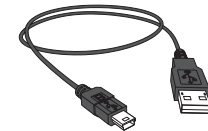

USB (PC) cable ([P.22](#))

Items sold separately

- The following items can be purchased at your nearest retailer.

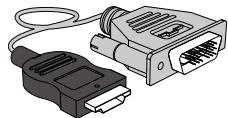

HDMI-DVI cable ([P.32](#))

Parts

Front Buttons

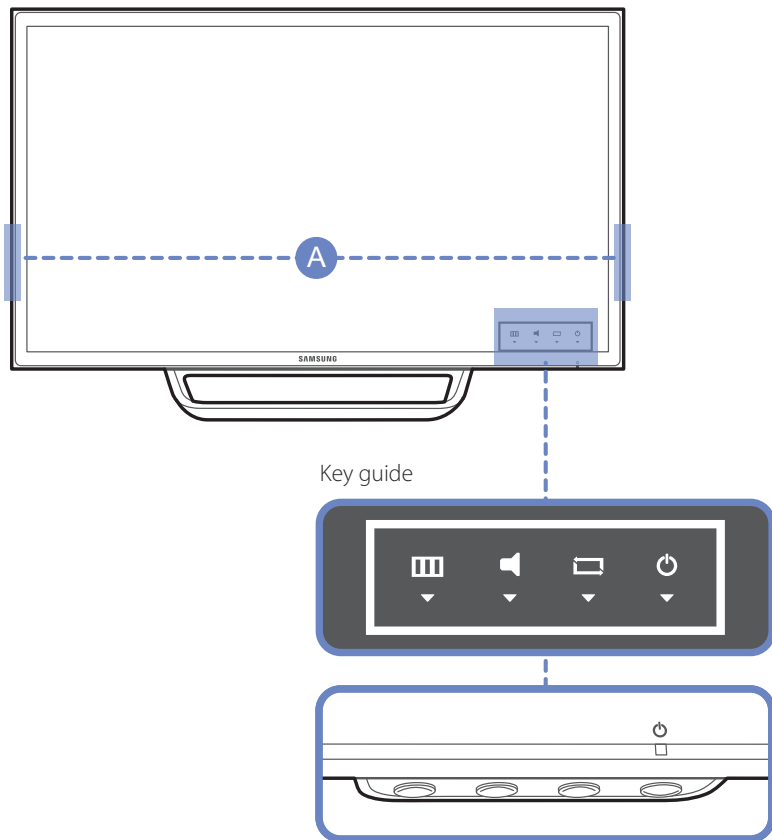

- The color and shape of parts may differ from what is shown. Specifications are subject to change without notice to improve quality.
- Press one of the four buttons, other than the power button, found at the bottom right front of the product. The key guide will appear.

Icons

Description



Display the OSD menu page.



Display the volume control menu page.



Change the input source (**HDMI 1** or **HDMI 2**).



Turn the power on or off.

The power indicator will be lit when the product is operating normally.

— For details on the power-saving function, refer to "Power-saving Function ([page 46](#))" in the product specifications.

— To reduce power consumption, it is best to remove the power cable when not using the product for an extended period of time.

A Speaker



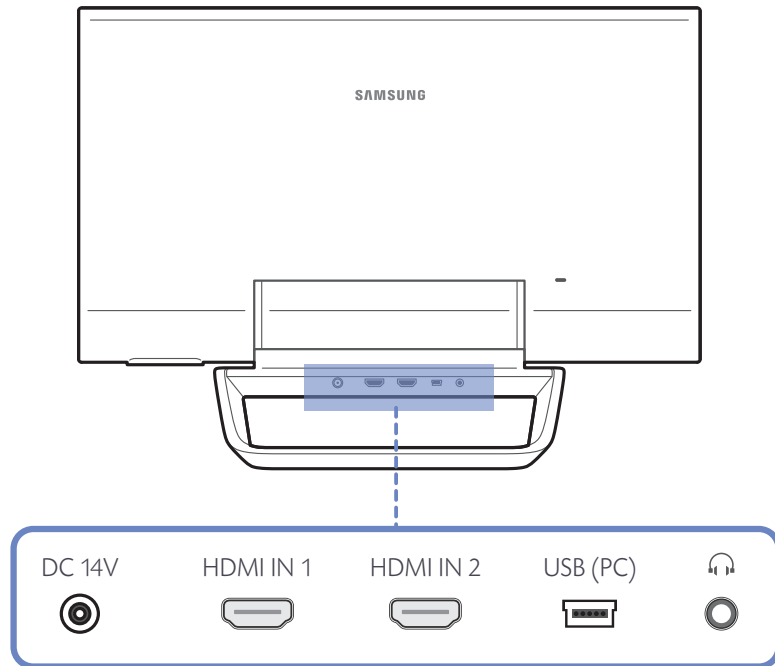

Connect a source device to the product using an HDMI cable to enable sound.

— Speakers are located on both sides of the product.

Reverse Side



— The color and shape of parts may differ from what is shown. Specifications are subject to change without notice to improve quality.

Port	Description
DC 14V 	Connect to a DC power adapter.
HDMI IN 1 HDMI IN 2 	Connect to a source device using an HDMI or HDMI-DVI cable.
USB (PC) 	To use the touch function of the product, connect the USB (PC) port on the product to a USB port on a PC using the USB (PC) cable provided with the product. — Only a PC can be connected to the port.
 	Connects to the audio of a source device.

Adjusting the Product Tilt

The color and shape of parts may differ from what is shown. Specifications are subject to change without notice to improve quality.

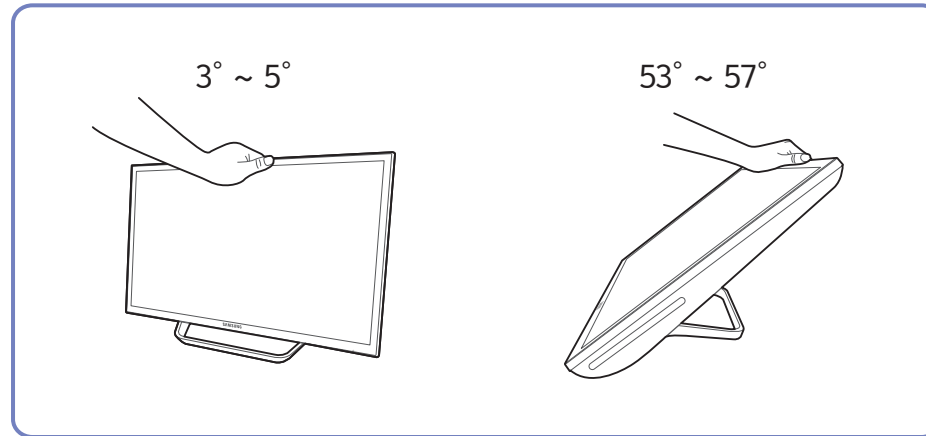

- You can adjust the product tilt.
- Grasp the top center of the product with your hand, then push or pull the product to tilt.

Anti-theft Lock

- An anti-theft lock allows you to use the product securely even in public places.
- The locking device shape and locking method depend on the manufacturer. Refer to the user guide provided with your anti-theft locking device for details.

To lock an anti-theft locking device:

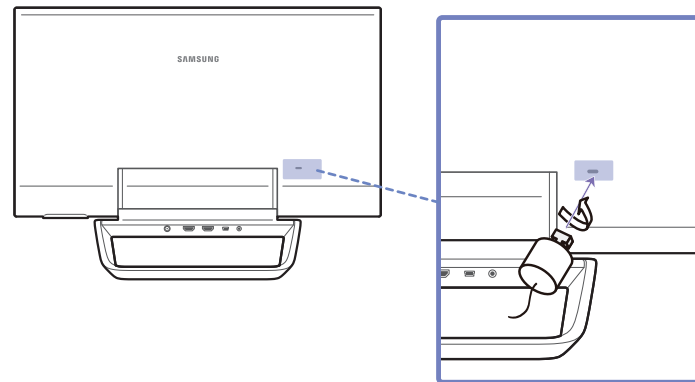

- 1 Fix the cable of your anti-theft locking device to a heavy object such as a desk.
- 2 Put one end of the cable through the loop on the other end.
- 3 Insert the locking device into the anti-theft lock slot at the back of the product.
- 4 Lock the locking device.
 - An anti-theft locking device can be purchased separately.
 - Refer to the user guide provided with your anti-theft locking device for details.
 - Anti-theft locking devices can be purchased at electronics retailers or online.

Chapter 03

Using MagicTune Touch

MagicTune Touch is designed to control monitors. The program allows you to conveniently control a monitor to adjust the screen brightness or color from a computer, without the need to use buttons on the monitor.

About MagicTune Touch

MagicTune Touch is designed to control monitors. The program allows you to conveniently control a monitor to adjust the screen brightness or color from a computer, without the need to use buttons on the monitor.

If the screen is controlled using **MagicTune Touch** when multiple monitors are connected, only the picture quality of the monitor that displays the **MagicTune Touch** screen is adjusted. To adjust the picture quality of another monitor, move the **MagicTune Touch** screen to the desired monitor and adjust the screen settings.

— The OSD menu provided on the product is not available while **MagicTune Touch** is running.

— Refer to the **MagicTune Touch** program user manual for further details.

Requirements

The following conditions are required to use **MagicTune Touch**.

- Windows 7 or Windows 8 (32-bit/64-bit)
- OS X 10.6 or OS X 10.7
- Samsung monitor

Installing/Uninstalling MagicTune Touch (Windows)

Installation

- 1 Run the **MagicTune Touch** installer program in the install CD.
 - If a software install popup does not appear on the main screen, go to **CD-ROM** → **AutoPlay** → **Manual** → **MagicTuneTouch** and run the **MagicTuneTouch** executable file.
- 2 Select an install language. Next, install the program, following the onscreen instructions.
- 3 When installation is complete, the **MagicTune Touch**  icon is created on the desktop and taskbar.
 - Press the F5 key (Refresh) if the execution icon does not appear.

Uninstallation

- 1 Go to **Settings** → **Control Panel** on the Start menu and double-click **Add or Remove Programs**.
- 2 Select **MagicTune Touch** from the list and click **Change/Remove**.

Installing MagicTune Touch (Mac)

Installation

- 1 Run **Index_for_Mac.html** from the install CD.
- 2 Select **MagicTune Touch**.
 - If a software install popup does not appear on the main screen, go to **CD-ROM** → **AutoPlay** → **Manual_mac** → **MagicTuneTouch**.
- 3 A folder containing the install program will appear.
- 4 Select **MagicTuneTouch.dmg**, and run the install program.
- 5 Select an install language. Next, install the program, following the onscreen instructions.

Chapter 04

Using a touchscreen monitor

Control a PC by tapping the screen instead of using an input device such as a keyboard or mouse.

Touchscreen monitor

Control a PC by tapping the screen instead of using an input device such as a keyboard or mouse. The touch screen functions by detecting a minute electric current that runs through your body (capacitive). Make sure to use the surface of your finger tip when tapping the screen.

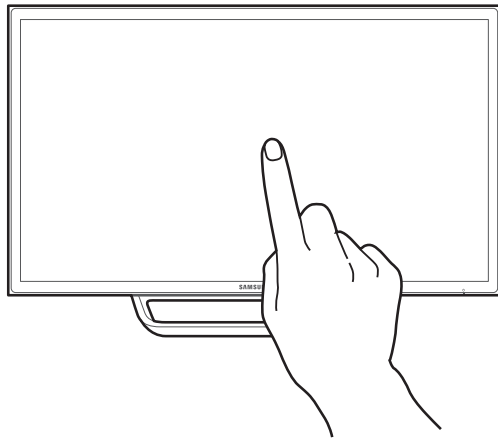

Requirements

The following conditions are required to use a touchscreen monitor.

- Windows 7 or Windows 8 (32-bit/64-bit)
 - This touchscreen monitor is optimized for Windows 8 Metro UI.
- OS X 10.6 or OS X 10.7
- Samsung monitor

Read below before using the product

- Take extra care to ensure an electrical substance does not contact the screen. The screen may not function properly if there is static.
- Do not press hard on the touch screen with your finger tip. Do not use a sharp object when tapping the screen. The screen may break or get damaged.
- Do not tap the screen while wearing a glove, with a dirty finger, or using something sharp such as your fingernail or a ballpoint pen. The screen may not function properly.
- Take extra care to ensure the screen does not contact moisture. The touch sensor may not function properly.
- Displaying a still image on the screen for an extended period of time may cause after images (screen degradation) or stains. Switch off the screen when not in use.
- Up to 10 multiple touch points are supported.

Connecting the touchscreen monitor

Connecting to a PC

1 Connect a PC to the product using an HDMI or HDMI-DVI cable.

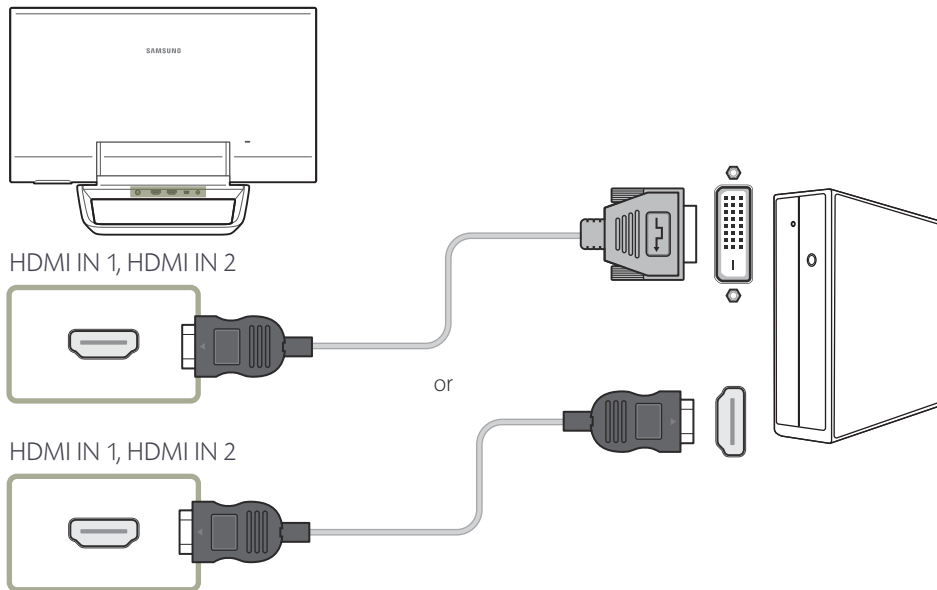

2 Connect the DC power adapter to the product and power outlet.

Connecting to a laptop or tablet PC

Connect a laptop or tablet PC to the product using the same method as when connecting a PC.

- When the monitor touch screen does not function after a touchscreen laptop or tablet PC is connected
 - First connect the HDMI cable according to the connection method. Next, connect the USB (PC) cable.
 - If the touch screen still does not function after all connections are established, disconnect and then connect the USB (PC) cable again.

3 After the power supply is connected, the product automatically detects and switches to the connected input source.

— If the screen appears blank, turn the product off and then on again.

4 Connect the **USB (PC)** port on the product to a USB port on the PC using the USB (PC) cable.

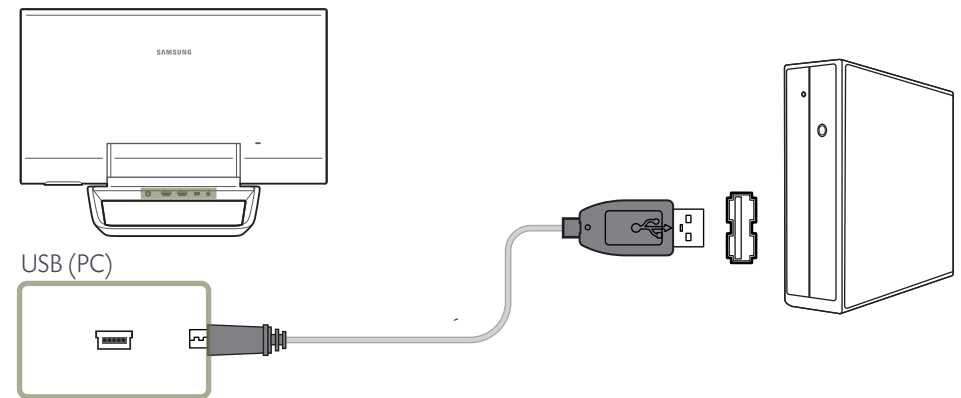

Configuring the touchscreen monitor settings

To properly use the touch function of the product in Windows, go to **Tablet PC Settings** and calibrate the product.

— First connect the touchscreen monitor before configuring the following settings.

Accessing the calibration menu

Go to **Tablet PC Settings** using the appropriate method according to the system configuration as shown below.

Accessing via Tablet PC Settings in Windows 7

Go to **Control Panel** → **Tablet PC Settings**. (Calibrate the product by referring to "Calibration" on [page 25](#).)

— If **Tablet PC Settings** is not found in the **Control Panel**, search for **Tablet PC Settings** from **Search Control Panel**.

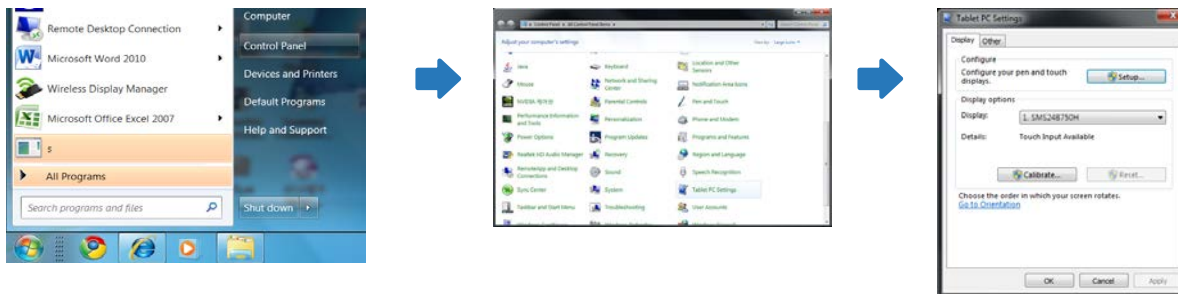

Accessing via Tablet PC Settings in Windows 8

Go to **Settings** → **Control Panel** → **Tablet PC Settings**. (Calibrate the product by referring to "Calibration" on [page 25](#).)

— If **Tablet PC Settings** is not found in the **Control Panel**, search for **Tablet PC Settings** from **Search Control Panel**.

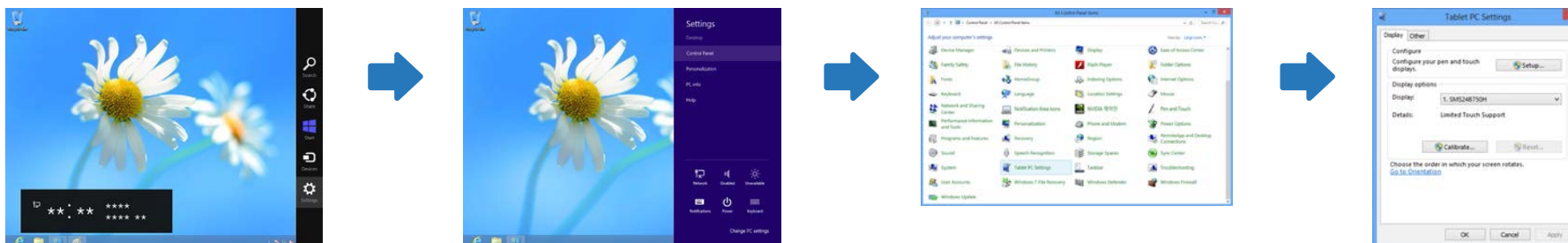

Accessing the calibration menu from MagicTune Touch

The following method is applicable for Windows 8. The same method applies to both Windows 7 and Windows 8.

- 1 Run **MagicTune Touch**.
- 2 Select **Touch Calibration** from the **Options** tab. Select **Start**.

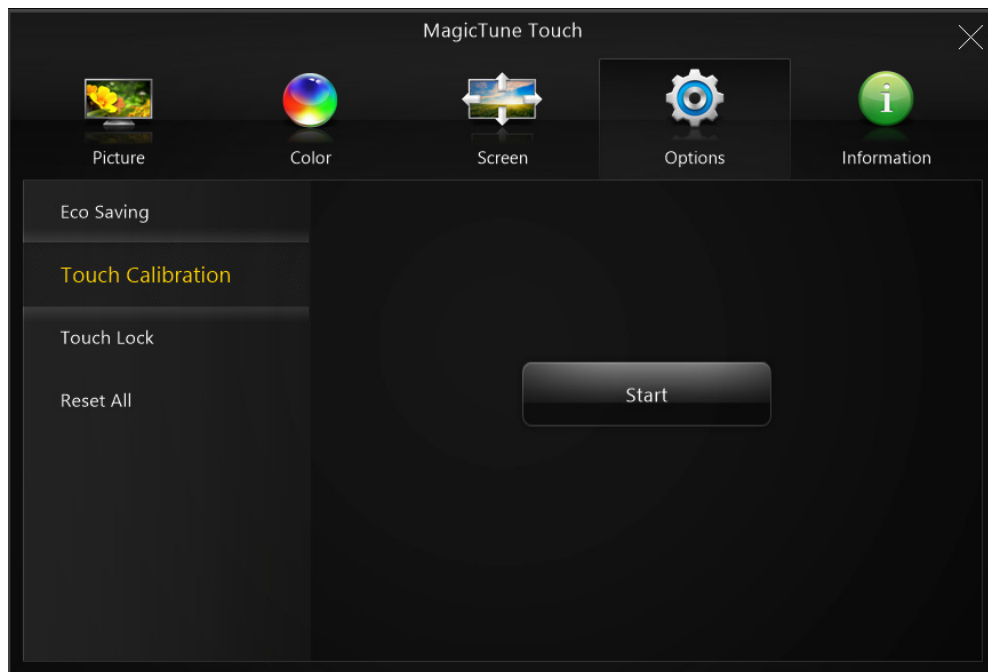

- 3 The following page appears.
(Calibrate the product by referring to "Calibration" on [page 25](#).)

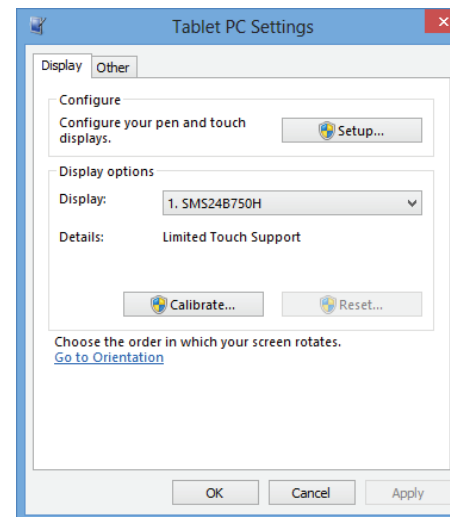

Calibration

- Instructions below are for Windows 8. The same method applies to both Windows 7 and Windows 8.
- After changing the screen size or PC/AV mode using the OSD menu, the monitor may need to be calibrated again.
- In the occurrence of an error during calibration, go to **Tablet PC Settings** → the **Display** tab. Tap **Reset**, and calibrate again.

1 In the **Display** tab, select **Setup** under **Configure**.

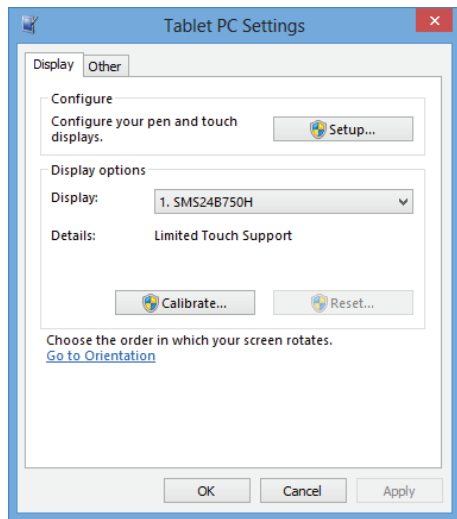

2 Tap the page displayed on the product with your finger.

- In dual monitor mode: If the following page does not appear on the product, press the Enter key to display the page.

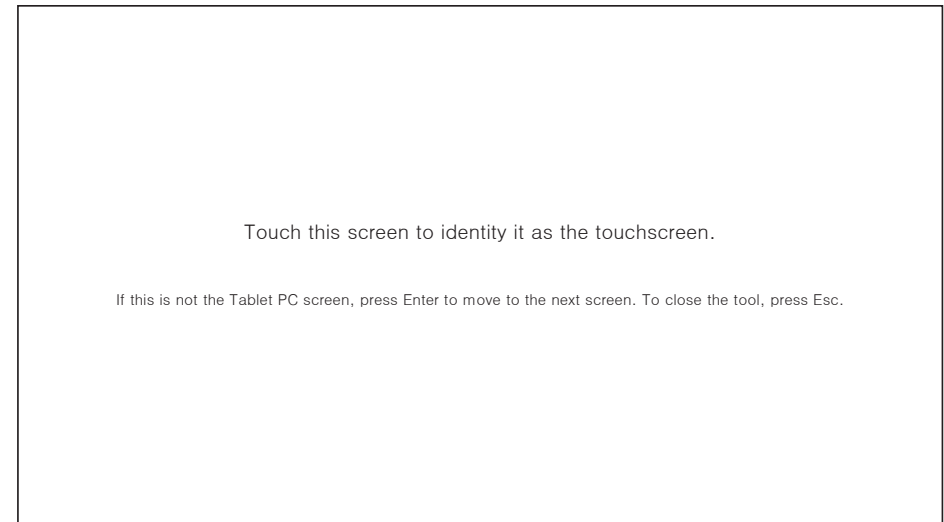

- 3 Select the product from **Display** under **Display options**. Next, select **Calibrate**.

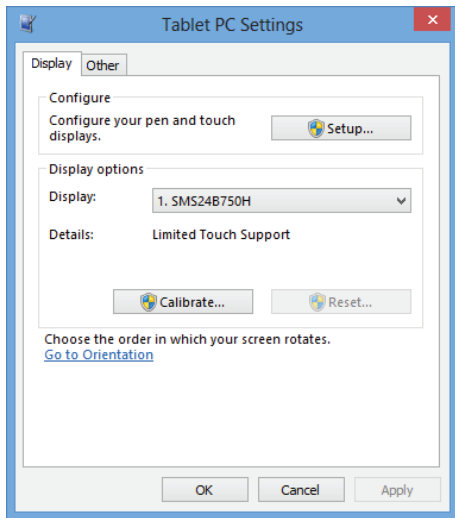

- 4 Perform calibration following the onscreen instructions displayed as shown in the image.

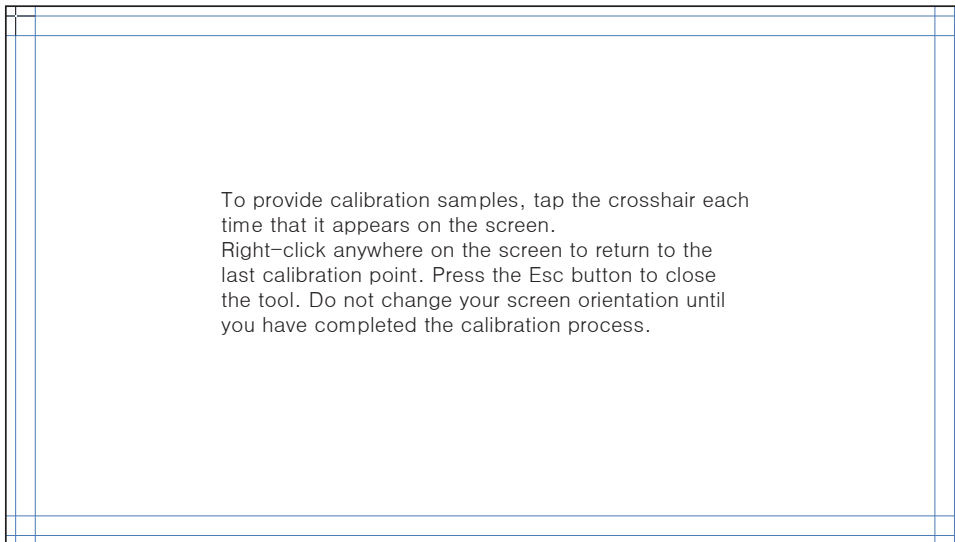

- 5 After calibration is complete, the message **Do you want to save the calibration data?** appears. Select **Yes** to save changes.

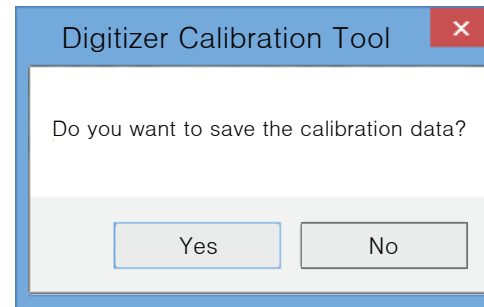

- 6 The touchscreen monitor has been calibrated successfully.

— Selecting **Reset** will remove the calibration data.

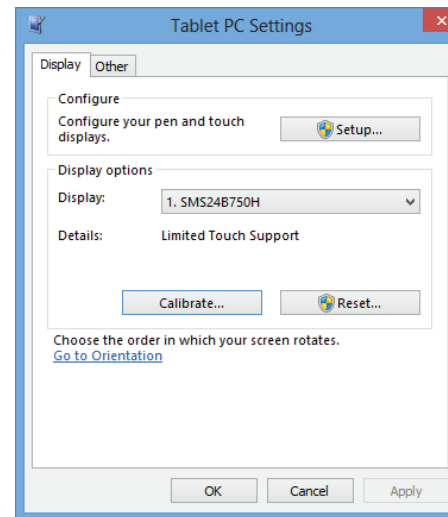

Configuring the touchscreen monitor settings from a Mac

To use the touch function of the product from a Mac computer, make sure to install the corresponding program as instructed below.

— The program can be found in the provided CD. For information about the latest program or technical support, go to the Samsung Electronics website (www.samsung.com).

Installing Touch Base

This program is required to use the basic touch function and zoom in/out gestures of the product.

1 Run **Index_for_Mac.html** from the install CD.

2 Select **Touch Base**.

— If a software install popup does not appear on the main screen, go to **CD-ROM** → **AutoPlay** → **Manual_mac** → **Touch Base**.

3 A folder containing the install program will appear.

4 Select **updd.dmg**, and run the install program.

5 Install the program following the on-screen instructions.

Controlling the screen

Basic touch functions

The control method is the same as when using a mouse

Tap

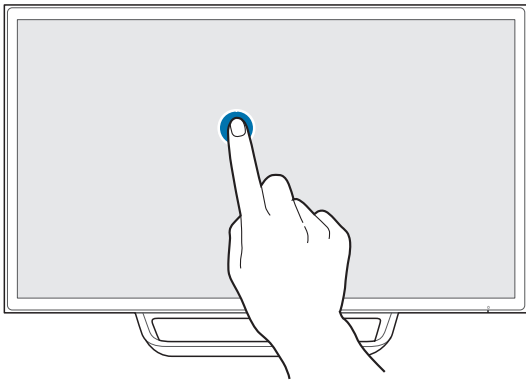

To select a function or menu item, tap the selection lightly on the screen. This is similar to clicking with a mouse.

Drag

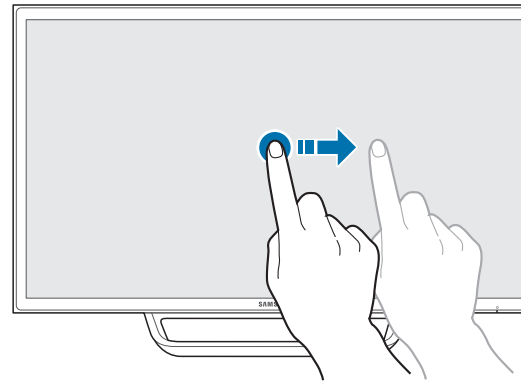

To move when viewing a webpage, map or gallery, drag in the desired direction. This is similar to dragging with a mouse.

Double tap

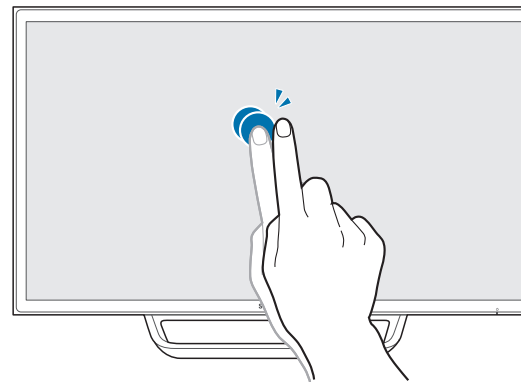

To run a selected program, double tap the selection. This is similar to double-clicking with a mouse.

Flick

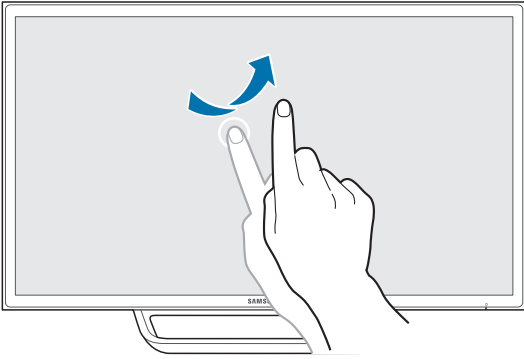

To move to the previous or next page when viewing a webpage or gallery, flick with your finger as shown in the image.

Zoom in/out

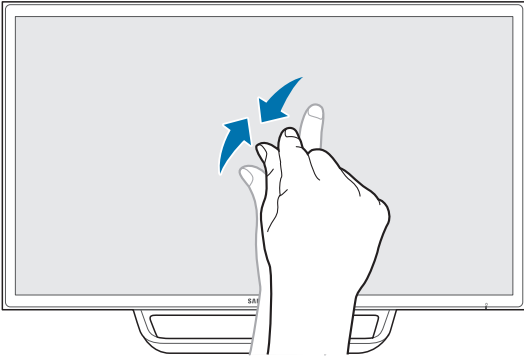

To zoom in or out when viewing a webpage, map or gallery, pinch with your fingers as shown in the image.

Notes

- To increase the touch input accuracy, enlarge the font or icons.
- A mouse can be useful when a more precise selection or input is required.

Chapter 05

Connecting and Using a Source Device

Before Connecting

Check the following before you connect this product with other devices.

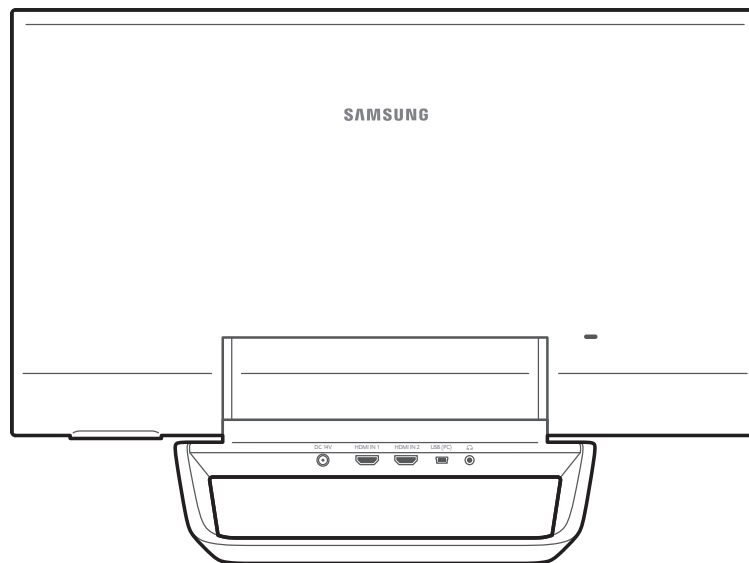

Pre-connection Checkpoints

- Before connecting a source device, read the user manual provided with it.
The number and locations of ports on source devices may differ from device to device.
- Do not connect the power cable until all connections are completed.
Connecting the power cable during connection may damage the product.

Connection Using an HDMI Cable

There are several methods available to connect a source device to the product.

Select the appropriate method according to the environment where you are using the product.

— Connecting parts may differ in different products.

Connecting to a PC

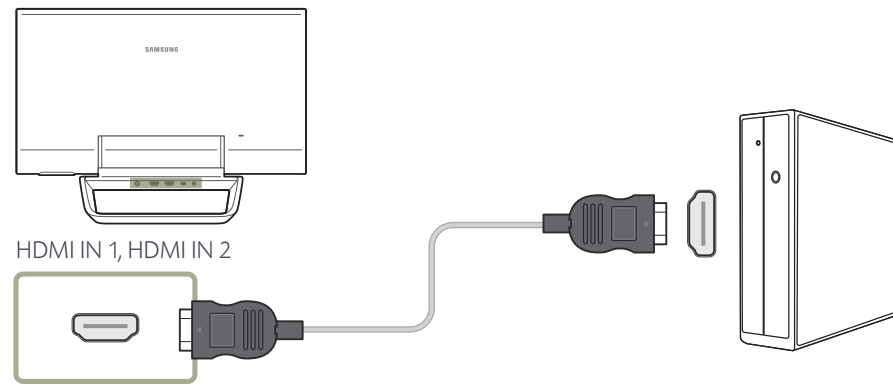

Connecting to a Video Device

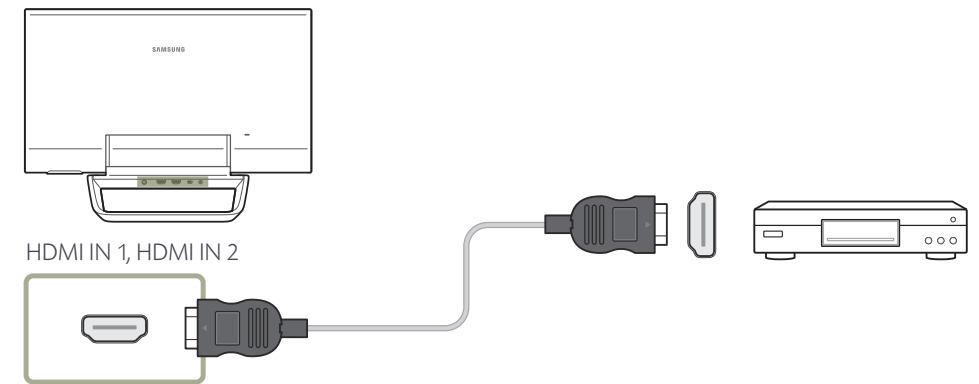

Connection Using an HDMI-DVI Cable

There are several methods available to connect a source device to the product.

Select the appropriate method according to the environment where you are using the product.

— Connecting parts may differ in different products.

— If the HDMI-DVI cable does not support both video and audio, an audio output device is required to enable sound.

Connecting to a PC

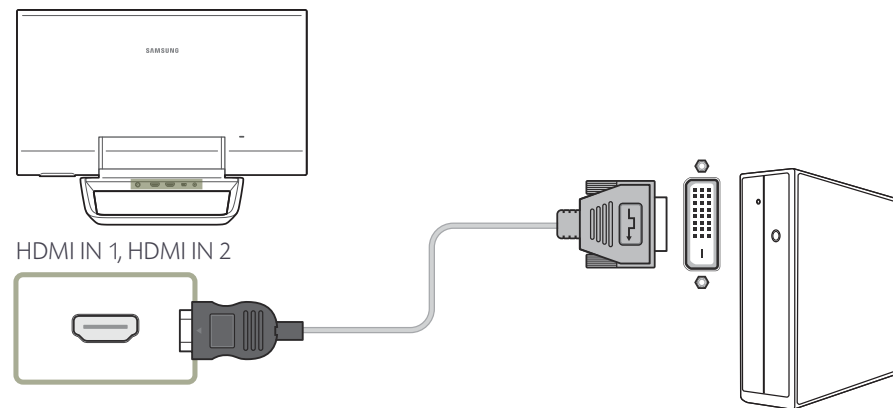

Connecting to a Video Device

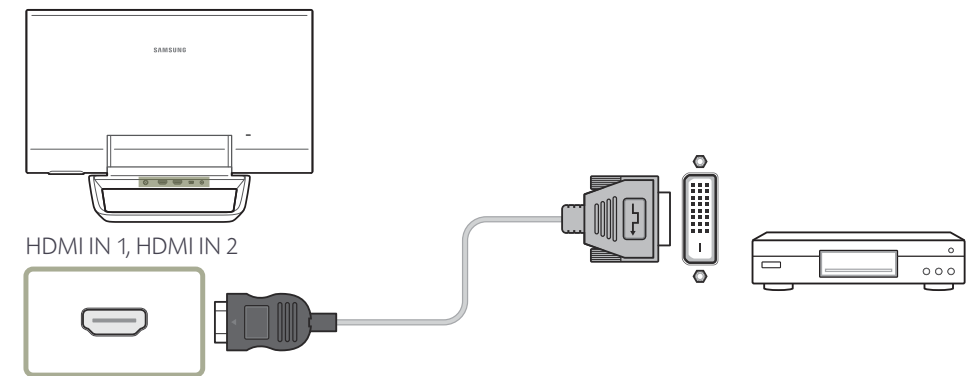

Connecting to an Audio System

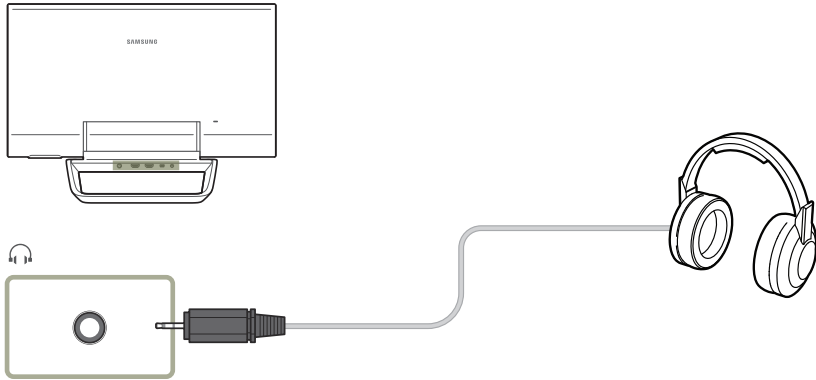

Connecting the Power

Connect the power cable to the DC power adapter. Next, connect the adapter to the product.

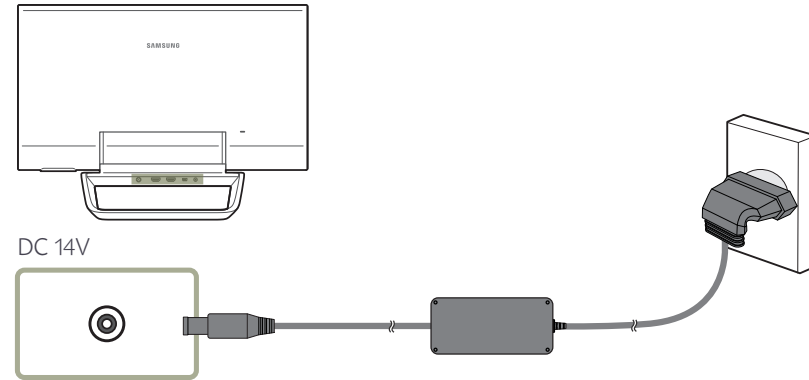

Changing the Resolution

- Adjust the resolution and refresh rate in Control Panel on your PC to obtain optimum picture quality.
- The picture quality of TFT-LCDs may degrade if the optimum resolution is not selected.

Changing the Resolution on Windows 7

Go to **Control Panel** → **Display** → **Screen Resolution**, and change the resolution.

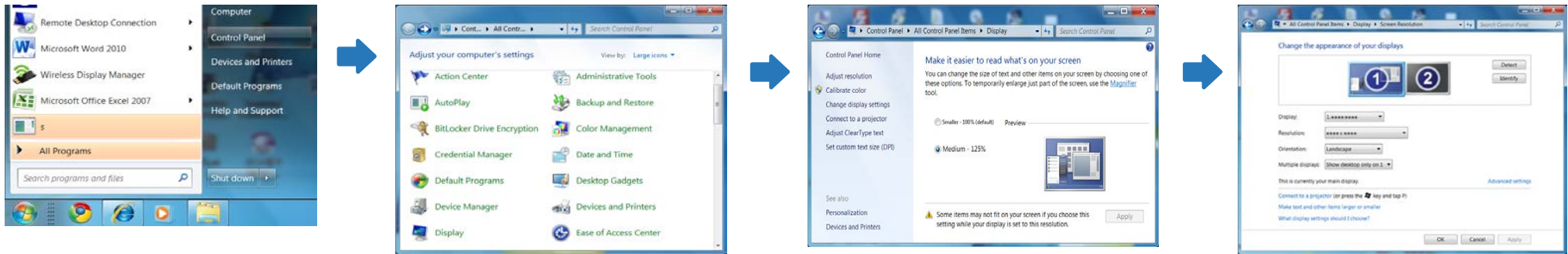

Changing the Resolution on Windows 8

Go to **Settings** → **Control Panel** → **Display** → **Screen Resolution**, and change the resolution.

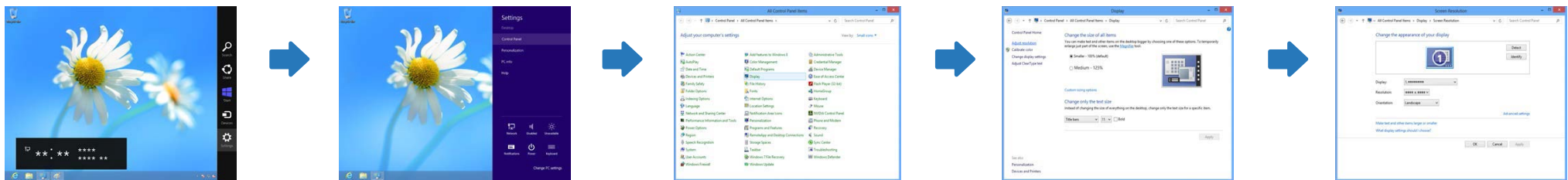

Chapter 06

OSD menu



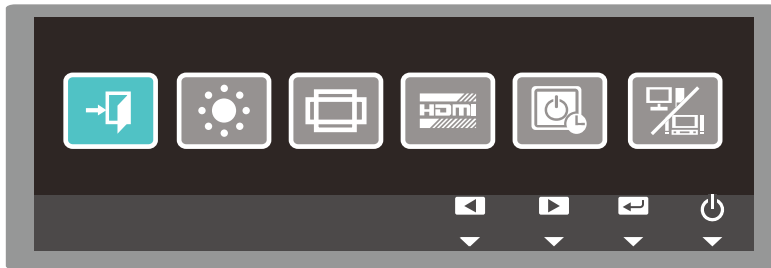

The OSD menu is not available while **MagicTune Touch** is running.

Exiting from the menu



Exit from the OSD menu as follows.

— Press one of the four buttons, other than the power button, found at the bottom right front of the product. The key guide will appear.

- 1 Tap the  button from the key guide.
- 2 Go to  using the   buttons, and tap .
- 3 The OSD menu is closed.



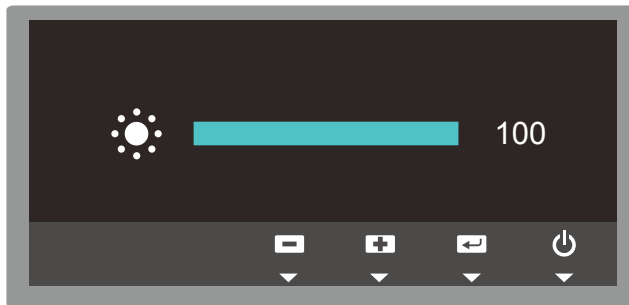





Adjusting the brightness



Brighten or darken the screen as follows (range: 0-100).

A higher value increases the screen brightness.

— Press one of the four buttons, other than the power button, found at the bottom right front of the product. The key guide will appear.

- 1 Tap the  button from the key guide.
- 2 Go to  using the   buttons, and tap .
- 3 Adjust the value using the   buttons, and tap .
- 4 Changes are applied and the OSD menu is closed.

Changing the screen size

- After changing the screen size, the monitor may need to be calibrated again.
- To calibrate the monitor again, refer to "Calibration" on [page 25](#).

In PC mode

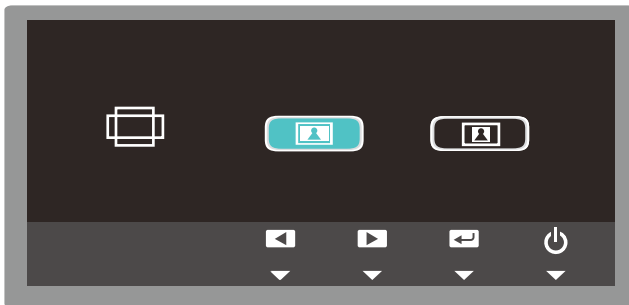

In AV mode















Change the screen size as follows.

Displayed options can vary between PC mode and AV mode.

See [page 38](#) for details on how to enable PC or AV mode.

- Press one of the four buttons, other than the power button, found at the bottom right front of the product. The key guide will appear.

- 1 Tap the  button from the key guide.
- 2 Go to  using the   buttons, and tap .
- 3 Go to the desired option using the   buttons, and tap .

 - In PC mode
 - : Stretch the picture to full screen regardless of the aspect ratio of the input source.
 - : Display the picture according to the aspect ratio of the input source.
 - In AV mode
 - : This mode is suitable to view the 4:3 aspect ratio picture of video content or standard broadcasts.
 - : This mode is suitable to view the 16:9 aspect ratio picture of DVD content or widescreen broadcasts.
 - : This mode displays input without truncating the original picture.

- 4 Changes are applied and the OSD menu is closed.

Configuring the HDMI black level



- This menu is available only when a source device is connected via HDMI.
- This menu may not be compatible with some source devices.



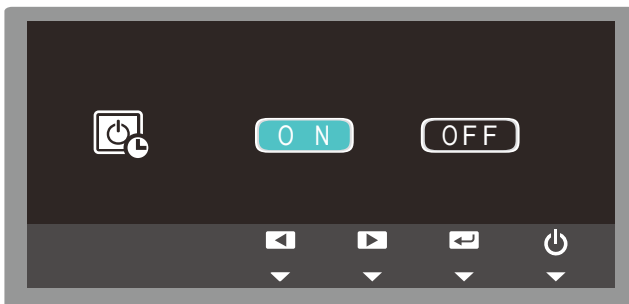



Enabling/disabling the off timer



- Once the off timer is enabled, the product automatically turns off after 4 hours. The setting for 4 hours cannot be changed.

If a DVD player or set-top box is connected to the product via an HDMI cable, the contrast and color may degrade and the screen may darken. If this is the case, improve the picture quality by adjusting the HDMI black level.

— Press one of the four buttons, other than the power button, found at the bottom right front of the product. The key guide will appear.

- 1 Tap the  button from the key guide.
- 2 Go to  using the   buttons, and tap .
- 3 Go to the desired option using the   buttons, and tap .



: Set the brightness of the darkest parts of the screen to be normal.







: Set the brightness of the darkest parts of the screen to be darker than Normal mode.

- 4 Changes are applied and the OSD menu is closed.

Set the product to turn off automatically if required as follows.

— Press one of the four buttons, other than the power button, found at the bottom right front of the product. The key guide will appear.

- 1 Tap the  button from the key guide.
- 2 Go to  using the   buttons, and tap .
- 3 Go to the desired option using the   buttons, and tap .

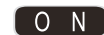

: Activate the off timer so that the product powers off automatically.



: Deactivate the off timer so that the product does not power off automatically.

- 4 Changes are applied and the OSD menu is closed.

Enabling PC or AV mode





- After changing the PC/AV mode, the monitor may need to be calibrated again.
- To calibrate the monitor again, refer to "Calibration" on [page 25](#).

Adjusting the volume



Enable PC or AV mode according to the source device connected to the product.

— Press one of the four buttons, other than the power button, found at the bottom right front of the product. The key guide will appear.

- 1 Tap the  button from the key guide.
- 2 Go to  using the   buttons, and tap .
- 3 Go to the desired option using the   buttons, and tap .





 : Enable PC mode. This mode is suitable for a PC.

 : Enable AV mode to enlarge the image size displayed on the product. This mode is suitable when viewing movies.

- 4 Changes are applied and the OSD menu is closed.

Adjust the volume as follows.

— Press one of the four buttons, other than the power button, found at the bottom right front of the product. The key guide will appear.

- 1 Tap the  button from the key guide.
- 2 Tap .
- 3 Adjust the volume using the   buttons, and tap .
- 4 Changes are applied and the OSD menu is closed.

Chapter 07

Troubleshooting Guide

Requirements Before Contacting Samsung Customer Service Center

Before calling Samsung Customer Service Center, test your product as follows. If the problem persists, contact Samsung Customer Service Center.

Testing the Product

Check if your product is operating normally by using the product test function. If the screen remains blank while the power LED blinks even when the product is correctly connected to a PC, perform product testing.

- 1 Power off both the PC and product.
- 2 Disconnect all the cables from the product.
- 3 Power on the product.
- 4 The following message indicates that the product is functioning properly.



If the screen remains blank, check the PC system, video controller and cable.

Checking the Resolution and Frequency

In a mode that exceeds the supported resolution (refer to supported resolutions), the following message will appear briefly.

— The displayed resolution may vary depending on the product or PC system settings.

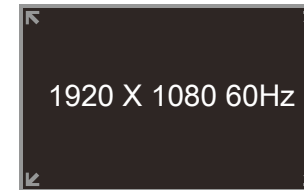

Check the followings.

Installation issue (PC mode)

The screen keeps switching on and off.

Check the cable connection between the product and PC, and ensure the connection is secure.

Blank spaces are found on all four sides of the screen when an HDMI or HDMI-DVI cable is connected to the product and PC.

The blank spaces found on the screen have nothing to do with the product.

Blank spaces on the screen are caused by the PC or graphics card. To resolve the problem, adjust the screen size in the HDMI or DVI settings for the graphics card.

If the graphics card settings menu does not have an option to adjust the screen size, update the graphics card driver to the latest version.

(Please contact the graphics card or computer manufacturer for further details about how to adjust the screen settings.)

Screen issue

The power LED is off. The screen will not switch on.

Make sure that the power cord is connected.

The following message appears on the screen.



Check that the product is connected correctly with a cable

Check that the device connected to the product is powered on.

The following message appears on the screen.

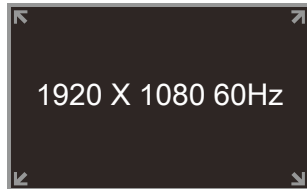

This message is displayed when a signal from the graphics card exceeds the product's maximum resolution and frequency.

Refer to the Standard Signal Mode Table([page 47](#)) and set the maximum resolution and frequency according to the product specifications.

Screen issue

The screen is not clear. The screen is blurry.

Check the cable connection to the product.

Remove any accessories (video extension cable, etc) and try again.

Set the resolution and frequency to the recommended level.

The screen appears unstable and shaky.

Check that the resolution and frequency of the PC and graphics card are set within a range compatible with the product. Then, change the screen settings if required by referring to the Additional Information on the product menu and the Standard Signal Mode Table([page 47](#)).

There are shadows or ghost images left on the screen.

The screen is too bright. The screen is too dark.

Adjust the **Brightness** and **Contrast** settings from **MagicTune Touch**.

Screen color is inconsistent.

Adjust the **Color Control** settings from **MagicTune Touch**.

White does not really look white.

Adjust the **Color Control** settings from **MagicTune Touch**.

There is no image on the screen and the power LED blinks every 0.5 to 1 second.

The product is in power-saving mode.

Press any key on the keyboard or move the mouse to return to the previous screen.

Sound issue

There is no sound.

Check the connection of the audio cable or adjust the volume.

Check the volume.

The volume is too low.

Adjust the volume.

If the volume is still low after turning it up to the maximum level, adjust the volume on your PC sound card or software program.

Source device issue

A beeping sound is heard when my PC is booting.

If a beeping sound is heard when your PC is booting, have your PC serviced.

Touch function issues

The touch function does not work.

Make sure not to use an object other than your finger when tapping the screen.

Make sure the screen or your finger is not wet.

Make sure you are not wearing a glove and your finger is not dirty.

The touch point does not match.

If a touch point is inaccurate, perform the touch calibration again.

— To calibrate the monitor again, refer to "Calibration" on [page 25](#).

The touch function is not working properly in a program.

If a Windows or Mac program not provided with Samsung monitors or a program installed on your PC is not working properly, contact the original software vendor.

A program is not working properly.

Q & A

Question

Answer

Refer to the user manual for your PC or graphics card for further instructions on adjustment.

What is the minimum touch area?

Ensure the touch area is at least 8mm in diameter when tapping with your finger.

How can I change the frequency?

Set the frequency on your graphics card.

- Windows 7: Go to **Control Panel** → **Appearance and Personalization** → **Display** → **Adjust resolution** → **Advanced Settings** → **Monitor** and adjust the frequency in **Monitor Settings**.
- Windows 8: Go to **Settings** → **Control Panel** → **Appearance and Personalization** → **Display** → **Adjust resolution** → **Advanced Settings** → **Monitor** and adjust the frequency in **Monitor Settings**.

How can I change the resolution?

- Windows 7: Go to **Control Panel** → **Appearance and Personalization** → **Display** → **Adjust Resolution** and adjust the resolution.
- Windows 8: Go to **Settings** → **Control Panel** → **Appearance and Personalization** → **Display** → **Adjust Resolution** and adjust the resolution.

How do I set powersaving mode?

- Windows 7: Set power-saving mode in **Control Panel** → **Appearance and Personalization** → **Personalize** → **Screen Saver Settings** or BIOS SETUP on the PC.
 - Windows 8: Set power-saving mode in **Settings** → **Control Panel** → **Appearance and Personalization** → **Personalize** → **Screen Saver Settings** or BIOS SETUP on the PC.
-

Chapter 08

Specifications

1 Size

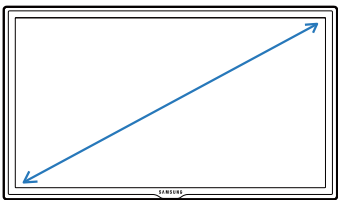

2 Display area

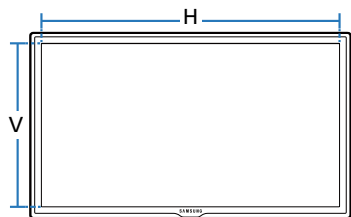

3 Dimensions (W x H x D)

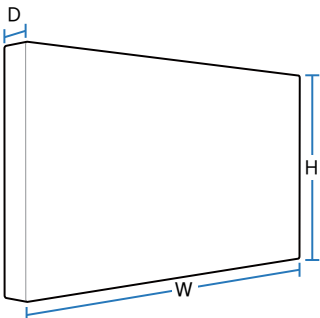

General

Model Name

S24C770

Panel	Size	24 Class (24 inches / 60.96 cm)
	Display area	531.36 mm (H) x 298.89 mm (V) / 20.9 inches (H) x 11.8 inches (V)
	Pixel Pitch	276.75(per one triad) mm (H) x 276.75 mm (V) / 10.9 inches(per one triad) (H) x 10.9 inches (V)
Dimensions (W x H x D)		562 x 374 x 192 mm / 22.1 x 14.7 x 7.6 inches
Weight		5.5 kg / 12.1 lb
Multi Touch Point		10 points
Operating system (OS)		Windows 7 or higher including Windows 8 Mac (version 10.6 or higher)
Display Color		16.7 M
View Angle (H / V)		178°
Sound Output (W)		3W x 2

Model Name**S24C770****Synchronization****Horizontal Frequency**

30 ~ 81 kHz

Vertical Frequency

56 ~ 75 Hz

Resolution**Optimum resolution**

1920 x 1080 @ 60 Hz

Maximum resolution

1920 x 1080 @ 60 Hz

Maximum Pixel Clock

148.5 MHz

Power Supply

This product uses 100 to 240V. Refer to the label at the back of the product as the standard voltage can vary in different countries.

Signal connectorsHDMI IN 1, HDMI IN 2, USB (PC),  (Audio Out)**Environmental conditions****Operating**

Temperature: 50°F ~ 104°F (10°C ~ 40°C)

Humidity: 10 % ~ 80 %, non-condensing

Storage

Temperature: -4°F ~ 113°F (-20°C ~ 45°C)

Humidity: 5 % ~ 95 %, non-condensing

— Due to the nature of the manufacturing of this product, approximately 1 pixel per million (1 ppm) may appear brighter or darker on the panel. This does not affect product performance.

— This device is a Class B digital apparatus.

(USA only)

Dispose unwanted electronics through an approved recycler.

To find the nearest recycling location, go to our website:

www.samsung.com/recyclingdirect or call, (877) 278 - 0799

PowerSaver

The power-saving function of this product reduces power consumption by switching off the screen and changing the color of the power LED if the product is not used for a specified period of time. The power is not turned off in power-saving mode. To switch the screen back on, press any key on the keyboard or move the mouse. Power-savign mode only functions when the product is connected to a PC with a power-saving function.

PowerSaver	Normal Operation	Power saving mode	Power off (Power button)
Power Indicator	On	Blinking	Amber
Power Consumption	32 W	0.3 W	0.3 W

— The displayed power consumption level can vary in different operating conditions or when settings are changed.

— SOG(Sync On Green) is not supported.

— To reduce the power consumption to 0, turn off the switch at the back or disconnect the power cord. Disconnect the power cable if you will not be using the product for an extended period of time (during vacation, etc.).

Preset Timing Modes

- This product can be set to only one resolution for each screen size to obtain the optimum picture quality due to the nature of the panel. Using a resolution other than the specified resolution may degrade the picture quality. To avoid this, it is recommended that you select the optimum resolution specified for your product.

The screen will automatically be adjusted if a signal that belongs to the following standard signal modes is transmitted from your PC. If the signal transmitted from the PC does not belong to the standard signal modes, the screen may be blank with the power LED on. In such a case, change the settings according to the following table by referring to the graphics card user manual.

Resolution	Horizontal Frequency (kHz)	Vertical Frequency (Hz)	Pixel Clock (MHz)	Sync Polarity (H/V)
VESA, 640 x 480	31.469	59.940	25.175	-/-
IBM, 720 x 400	31.469	70.087	28.322	-/+
MAC, 640 x 480	35.000	66.667	30.240	-/-
MAC, 832 x 624	49.726	74.551	57.284	-/-
MAC, 1152 x 870	68.681	75.062	100.000	-/-
VESA, 640 x 480	37.861	72.809	31.500	-/-
VESA, 640 x 480	37.500	75.000	31.500	-/-
VESA, 800 x 600	35.156	56.250	36.000	+/+
VESA, 800 x 600	37.879	60.317	40.000	+/+
VESA, 800 x 600	48.077	72.188	50.000	+/+
VESA, 800 x 600	46.875	75.000	49.500	+/+
VESA, 1024 x 768	48.363	60.004	65.000	-/-
VESA, 1024 x 768	56.476	70.069	75.000	-/-
VESA, 1024 x 768	60.023	75.029	78.750	+/+
VESA, 1152 x 864	67.500	75.000	108.000	+/+

– Horizontal Frequency

The time to scan one line connecting the right edge to the left edge of the screen horizontally is called the Horizontal Cycle and the inverse number of the Horizontal Cycle is called the Horizontal Frequency.

Unit: kHz

– Vertical Frequency

Like a fluorescent lamp, the screen has to repeat the same image many times per second to display an image to the user. The frequency of this repetition is called the Vertical Frequency or Refresh Rate.

Unit: Hz

Resolution	Horizontal Frequency (kHz)	Vertical Frequency (Hz)	Pixel Clock (MHz)	Sync Polarity (H/V)
VESA, 1280 x 720	45.000	60.000	74.250	+/+
VESA, 1280 x 800	49.702	59.810	83.500	-/+
VESA, 1280 x 1024	63.981	60.020	108.000	+/+
VESA, 1280 x 1024	79.976	75.025	135.000	+/+
VESA, 1440 x 900	55.935	59.887	106.500	-/+
VESA, 1600 x 900	60.000	60.000	108.000	+/+
VESA, 1680 x 1050	65.290	59.954	146.250	-/+
VESA, 1920 x 1080	67.500	60.000	148.500	+/+

Chapter 09

Appendix

Contact SAMSUNG WORLD WIDE

— If you have any questions or comments relating to Samsung products, please contact the SAMSUNG customer care center.

NORTH AMERICA

U.S.A	1-800-SAMSUNG (726-7864)	http://www.samsung.com
CANADA	1-800-SAMSUNG (726-7864)	http://www.samsung.com/ca (English) http://www.samsung.com/ca_fr (French)
MEXICO	01-800-SAMSUNG (726-7864)	http://www.samsung.com

LATIN AMERICA

ARGENTINE	0800-333-3733	http://www.samsung.com
BOLIVIA	800-10-7260	http://www.samsung.com
BRAZIL	0800-124-421 4004-0000	http://www.samsung.com
CHILE	800-SAMSUNG (726-7864) From mobile 02-482 82 00	http://www.samsung.com
COLOMBIA	01-8000112112	http://www.samsung.com

LATIN AMERICA

COSTA RICA	0-800-507-7267	http://www.samsung.com/latin (Spanish) http://www.samsung.com/latin_en (English)
DOMINICA	1-800-751-2676	http://www.samsung.com/latin (Spanish) http://www.samsung.com/latin_en (English)
ECUADOR	1-800-10-7267	http://www.samsung.com/latin (Spanish) http://www.samsung.com/latin_en (English)
EL SALVADOR	800-6225	http://www.samsung.com/latin (Spanish) http://www.samsung.com/latin_en (English)
GUATEMALA	1-800-299-0013	http://www.samsung.com/latin (Spanish) http://www.samsung.com/latin_en (English)
HONDURAS	800-27919267	http://www.samsung.com/latin (Spanish) http://www.samsung.com/latin_en (English)
JAMAICA	1-800-234-7267	http://www.samsung.com
NICARAGUA	00-1800-5077267	http://www.samsung.com/latin (Spanish) http://www.samsung.com/latin_en (English)
PANAMA	800-7267	http://www.samsung.com/latin (Spanish) http://www.samsung.com/latin_en (English)
PERU	0-800-777-08	http://www.samsung.com
PUERTO RICO	1-800-682-3180	http://www.samsung.com
TRINIDAD & TOBAGO	1-800-SAMSUNG (726-7864)	http://www.samsung.com
VENEZUELA	0-800-100-5303	http://www.samsung.com

EUROPE

AUSTRIA	0810 - SAMSUNG (7267864, € 0.07/min)	http://www.samsung.com
BELGIUM	02-201-24-18	http://www.samsung.com/be (Dutch) http://www.samsung.com/be_fr (French)
BOSNIA	05 133 1999	http://www.samsung.com
BULGARIA	07001 33 11, normal tariff	http://www.samsung.com
CROATIA	062 SAMSUNG (062 726 7864)	http://www.samsung.com
CYPRUS	8009 4000 only from landline (+30) 210 6897691 from mobile and land line	http://www.samsung.com
CZECH	800 - SAMSUNG (800-726786)	http://www.samsung.com
	Samsung Electronics Czech and Slovak, s.r.o., Oasis Florenc, Sokolovská 394/17, 180 00, Praha 8	
DENMARK	70 70 19 70	http://www.samsung.com
EIRE	0818 717100	http://www.samsung.com
ESTONIA	800-7267	http://www.samsung.com
FINLAND	09 85635050	http://www.samsung.com
FRANCE	01 48 63 00 00	http://www.samsung.com
GERMANY	0180 5 SAMSUNG bzw. 0180 5 7267864* (*0,14 €/Min. aus dem dt. Festnetz, aus dem Mobilfunk max. 0,42 €/Min.)	http://www.samsung.com
GREECE	80111-SAMSUNG (80111 726 7864) only from land line (+30) 210 6897691 from mobile and land line	http://www.samsung.com
HUNGARY	06-80-SAMSUNG (726-7864)	http://www.samsung.com

EUROPE

ITALIA	800-SAMSUNG (726-7864)	http://www.samsung.com
LATVIA	8000-7267	http://www.samsung.com
LITHUANIA	8-800-77777	http://www.samsung.com
LUXEMBURG	261 03 710	http://www.samsung.com
MONTENEGRO	020 405 888	http://www.samsung.com
NETHERLANDS	0900-SAMSUNG (0900-7267864) (€ 0,10/Min)	http://www.samsung.com
NORWAY	815 56480	http://www.samsung.com
POLAND	0 801-1SAMSUNG (172-678) +48 22 607-93-33	http://www.samsung.com
PORTUGAL	808 20-SAMSUNG (808 20 7267)	http://www.samsung.com
ROMANIA	08008 SAMSUNG (08008 726 7864) TOLL FREE No.	http://www.samsung.com
SERBIA	0700 SAMSUNG (0700 726 7864)	http://www.samsung.com
SLOVAKIA	0800 - SAMSUNG (0800-726 786)	http://www.samsung.com
SPAIN	902 - 1 - SAMSUNG (902 172 678)	http://www.samsung.com
SWEDEN	0771 726 7864 (SAMSUNG)	http://www.samsung.com
SWITZERLAND	0848 - SAMSUNG (7267864, CHF 0.08/min)	http://www.samsung.com/ch (German) http://www.samsung.com/ch_fr (French)
U.K	0330 SAMSUNG (7267864)	http://www.samsung.com

CIS

ARMENIA	0-800-05-555	http://www.samsung.com
AZERBAIJAN	088-55-55-555	http://www.samsung.com
BELARUS	810-800-500-55-500	http://www.samsung.com
GEORGIA	0-800-555-555	http://www.samsung.com
KAZAKHSTAN	8-10-800-500-55-500 (GSM: 7799)	http://www.samsung.com
KYRGYZSTAN	00-800-500-55-500	http://www.samsung.com
MOLDOVA	0-800-614-40	http://www.samsung.com
MONGOLIA	+7-800-555-55-55	http://www.samsung.com
RUSSIA	8-800-555-55-55	http://www.samsung.com
TADJIKISTAN	8-10-800-500-55-500	http://www.samsung.com
UKRAINE	0-800-502-000	http://www.samsung.com/ua (Ukrainian) http://www.samsung.com/ua_ru (Russian)
UZBEKISTAN	8-10-800-500-55-500	http://www.samsung.com

ASIA PACIFIC

AUSTRALIA	1300 362 603	http://www.samsung.com
CHINA	400-810-5858	http://www.samsung.com
HONG KONG	(852) 3698-4698	http://www.samsung.com/hk (Chinese) http://www.samsung.com/hk_en (English)

ASIA PACIFIC

INDIA	1800 1100 11 3030 8282 1800 3000 8282 1800 266 8282	http://www.samsung.com
INDONESIA	0800-112-8888 021-5699-7777	http://www.samsung.com
JAPAN	0120-327-527	http://www.samsung.com
MALAYSIA	1800-88-9999	http://www.samsung.com
NEW ZEALAND	0800 SAMSUNG (0800 726 786)	http://www.samsung.com
PHILIPPINES	1-800-10-SAMSUNG (726-7864) for PLDT 1-800-3-SAMSUNG (726-7864) for Digitel 1-800-8-SAMSUNG (726-7864) for Globe 02-5805777	http://www.samsung.com
SINGAPORE	1800-SAMSUNG (726-7864)	http://www.samsung.com
TAIWAN	0800-329-999 0266-026-066	http://www.samsung.com
THAILAND	1800-29-3232 02-689-3232	http://www.samsung.com
VIETNAM	1 800 588 889	http://www.samsung.com

MIDDLE EAST

BAHRAIN	8000-4726	http://www.samsung.com/ae (English) http://www.samsung.com/ae_ar (Arabic)
EGYPT	08000-726786	http://www.samsung.com
IRAN	021-8255	http://www.samsung.com
JORDAN	800-22273 065777444	http://www.samsung.com
KUWAIT	183-2255	http://www.samsung.com/ae (English) http://www.samsung.com/ae_ar (Arabic)
MOROCCO	080 100 2255	http://www.samsung.com
OMAN	800-SAMSUNG (726-7864)	http://www.samsung.com/ae (English) http://www.samsung.com/ae_ar (Arabic)
SAUDI ARABIA	9200-21230	http://www.samsung.com/ae (English) http://www.samsung.com/ae_ar (Arabic)
TURKEY	444 77 11	http://www.samsung.com
U.A.E	800-SAMSUNG (726-7864)	http://www.samsung.com

AFRICA

ANGOLA	91-726-7864	http://www.samsung.com
BOTSWANA	0800-726-000	http://www.samsung.com
CAMEROON	7095- 0077	http://www.samsung.com
COTE D'IVOIRE	8000 0077	http://www.samsung.com

AFRICA

GHANA	0800-10077 0302-200077	http://www.samsung.com
KENYA	0800 545 545	http://www.samsung.com
NAMIBIA	8197267864	http://www.samsung.com
NIGERIA	0800-726-7864	http://www.samsung.com
SENEGAL	800-00-0077	http://www.samsung.com
SOUTH AFRICA	0860-SAMSUNG (726-7864)	http://www.samsung.com
TANZANIA	0685 88 99 00	http://www.samsung.com
UGANDA	0800 300 300	http://www.samsung.com
ZAMBIA	211350370	http://www.samsung.com

Responsibility for the Pay Service(Cost to Customers)

— When the service is requested, in spite of in warranty, we may charge you for a visit from a service technician in the following cases.

Not a product defect

Cleaning of the product, Adjustment, Explanation, Re-installation and etc.

- If a service technician gives instructions on how to use product or simply adjusts options without disassembling product.
- If a defect is caused by external environmental factors (Internet, Antenna, Wired Signal, etc.)
- If a product is reinstalled or devices are connected additionally after installing the purchased product for the first time.
- If a product is reinstalled to move to a different spot or to move to a different house.
- If customer requests instructions on how to use because of another company's product.
- If customer requests instructions on how to use the network or another company's program.
- If customer requests software installation and setup for the product.
- If a service technician removes/cleans dusts or foreign materials inside of the product.
- If customer requests an installation additionally after purchasing a product through home-shopping or online.

A Product damage caused by customer's fault

Product damage caused by customer's mishandling or wrong repair

If a product damage is caused by;

- External impact or drop.
- Use of supplies or separately sold product unspecified by Samsung.
- Repair from a person besides an engineer of outsourcing service company or partner of Samsung Electronics Co., Ltd.
- Remodeling or repairing the product by customer.
- Using it with incorrect voltage or non-authorized electrical connections.
- Not following the "cautions" in User Manual.

Others

- If product fails by natural disaster. (lightning, fire, earthquake, flood damage, etc)
- If consumable components are all used up. (Battery, Toner, Fluorescent lights, Head, Vibrator, Lamp, Filter, Ribbon, etc.)

— If customer requests a service in case the product has no defect, service fee may be charged. So please read User Manual first.

Correct Disposal

Correct Disposal of This Product (Waste Electrical & Electronic Equipment)



(Applicable in countries with separate collection systems)

This marking on the product, accessories or literature indicates that the product and its electronic accessories (e.g. charger, headset, USB cable) should not be disposed of with other household waste at the end of their working life. To prevent possible harm to the environment or human health from uncontrolled waste disposal, please separate these items from other types of waste and recycle them responsibly to promote the sustainable reuse of material resources.

Household users should contact either the retailer where they purchased this product, or their local government office, for details of where and how they can take these items for environmentally safe recycling.

Business users should contact their supplier and check the terms and conditions of the purchase contract. This product and its electronic accessories should not be mixed with other commercial wastes for disposal.

Correct disposal of batteries in this product



(Applicable in countries with separate collection systems)

This marking on the battery, manual or packaging indicates that the batteries in this product should not be disposed of with other household waste at the end of their working life. Where marked, the chemical symbols Hg, Cd or Pb indicate that the battery contains mercury, cadmium or lead above the reference levels in EC Directive 2006/66. If batteries are not properly disposed of, these substances can cause harm to human health or the environment.

To protect natural resources and to promote material reuse, please separate batteries from other types of waste and recycle them through your local, free battery return system.

License



The terms HDMI and HDMI High-Definition Multimedia Interface, and the HDMI Logo are trademarks or registered trademarks of HDMI Licensing LLC in the United States and other countries.

Open Source Licence Notice

In the case of using open source software, Open Source Licences are available on the product menu. Open Source Licence Notice is written only English.

Terminology

480i / 480p / 720p / 1080i /

1080p_____ Each of the scanning rates above refers to the number of effective scanning lines that decides the screen resolution. The scanning rate may be indicated in i (interlaced) or p (progressive), depending on the scanning method.

- Scanning

Scanning refers to a process of sending pixels that form an image progressively. A larger number of pixels will deliver a clearer and more vivid picture.

- Progressive

In progressive scan mode, all lines of pixels are scanned one by one (progressively) on the screen.

- Interlaced

In interlaced scan mode, every other line of pixels is scanned from top to bottom first and then the remaining lines of pixels (that were not scanned) are scanned.

Non-interlace Mode and Interlace Mode_____

Non-interlace mode (progressive scan) displays a horizontal line from the top to the bottom of a screen progressively. Interlace mode displays the odd number lines first and the even number lines next. Non-interlace mode is mainly used in monitors as it produces screen clarity and interlace mode is mainly used in TVs.

Dot Pitch_____

The product and screen consist of red, green and blue dots. A shorter distance between the dots produces a higher resolution. Dot pitch refers to the distance between the shortest distance between dots of the same color. Dot pitch is measured in millimeters.

Vertical Frequency_____ The product displays a single image many times per second (like a fluorescent light that flickers) to display an image for a viewer to see. The rate of a single image being displayed repeatedly per second is called vertical frequency or refresh rate. Vertical frequency is measured in Hz. E.g. 60Hz refers to a single image being displayed 60 times in one second.

Horizontal Frequency_____ The time required to scan a single line from the left to the right side of the screen is called a horizontal cycle. The reciprocal number of a horizontal cycle is called horizontal frequency. Horizontal frequency is measured in kHz.

Source_____ Input source refers to a video source device connected to the product such as a camcorder or video or DVD player.

Plug & Play_____ Plug & Play is a function that allows the automatic exchange of information between a monitor and PC to produce an optimum display environment. The product uses VESA DDC (international standard) to execute Plug & Play.

Resolution_____ Resolution is the number of horizontal dots (pixels) and vertical dots (pixels) that form a screen. It represents the level of display detail. A higher resolution enables more data to be displayed on the screen and is useful to perform multiple tasks simultaneously.

E.g. A resolution of 1920 X 1080 consists of 1,920 horizontal pixels (horizontal resolution) and 1,080 vertical pixels (vertical resolution).

DVD (Digital Versatile Disc)_____ DVD refers to a CD-sized mass storage disk where you can save multimedia (audio, video or game) applications using MPEG-2 video compression technology.

HDMI (High Definition Multimedia Interface)_____ It is an interface that can be connected to a digital audio source as well as a high-definition video source by using a single cable without compression.