

Migrating from dc voltage dividers to modern reference multimeters

Introduction

Until the late 1980's electrical calibration systems used to compare primary and secondary voltages and resistance standards consisted of several different components. Systems like the Fluke 7105A and the Datron 4900 were the backbone of the majority of electrical calibration laboratories the world over. These systems were specifically combined to provide a traceable source, according to a set of measurement parameters. For example, the Fluke 7105A system comprised the following instruments:

- Fluke 720A Kelvin Varley Divider
- Fluke 750A Reference Divider
- Fluke 335A DC Voltage Standard
- Fluke 721A Lead Compensator
- 845AR High Impedance Null Detectors

Similarly, a comparable system from Datron (later acquired by Fluke in January 2000) was also available. Much like the Fluke 7105A, the Datron 4900 system included:

- 4901 Calibration Bridge/Lead Compensator
- 4902 DC Voltage Divider
- 4903 DC Calibration Unit
- 4904 Standard Cell Buffer

However, as new innovative technology and techniques were introduced, both the 7105A and 4900 calibration systems were soon replaced. So what caused their extinction?

Application Note

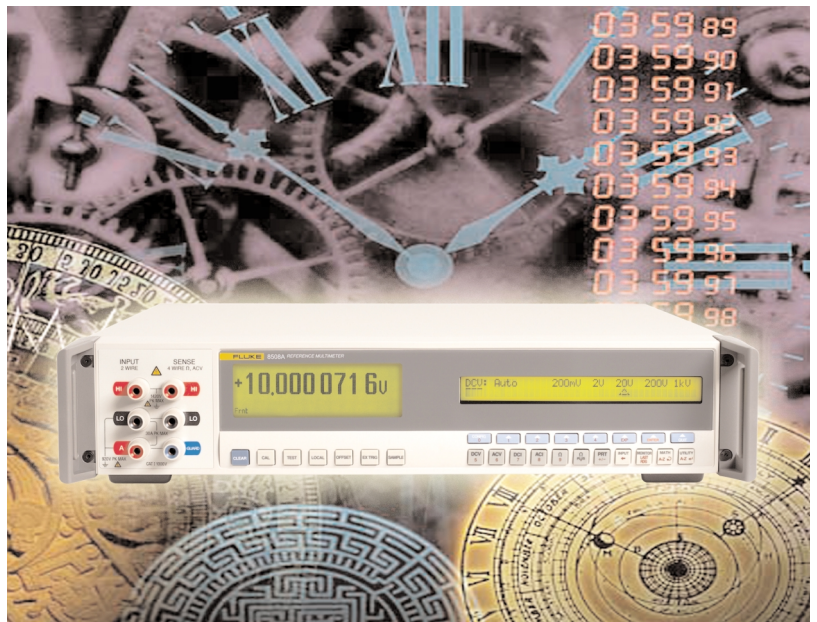

Fig. 1 Fluke 7105A calibration system



Fig. 2 Datron 4900 calibration system

Evolution caused these more mature calibration systems to begin the road to obsolescence

There have been several contributing factors to the demise of the old 7105A and 4900 calibration systems. First, the development of artifact calibration has not only consolidated the system into a single device, but has also fully automated the process. Second, the design of modern calibrators incorporates pulse width modulation (PWM) techniques to maintain a 'right by design philosophy' that provides extremely repeatable source linearity. Furthermore, zener reference technology improved, and, when incorporated within calibration equipment, subsequently improved stability reducing uncertainties. Finally, high resolution DMMs like the Wavetek 1281 then managed to combine these features into a highly accurate electrical measurement instrument.

More recently, the introduction of the Fluke 8508A Reference Multimeter has taken all of these philosophies a step further to improve accuracy, linearity and stability, and has combined them into a functionally versatile, easy to use solution. This has enabled metrologists to perform highly accurate and automated measurement tasks within a single instrument, replacing the need for Kelvin-Varley dividers, null detectors, resistance bridges and even PRT (Platinum Resistance Thermometer) calibrators. This ultimately means faster calibrations, reduced support costs, greater throughput and minimal manual operations.

Calibrators evolve with pulse width modulation (PWM)

Pulse width modulation topology can be found in a variety of applications, including various telecommunications applications, power generation and signal processing. Because of its exceptional linearity benefits, most calibrators today now include this technique in their own internal ratio divider. Such a circuit is typically made up from a two stage switching FET design with synchronous control clock. This circuit passes the dc reference voltage through the switching FET array and then filters their summed outputs to provide an average output voltage that is determined by the resulting waveform's duty cycle. (see figures 3 and 4).

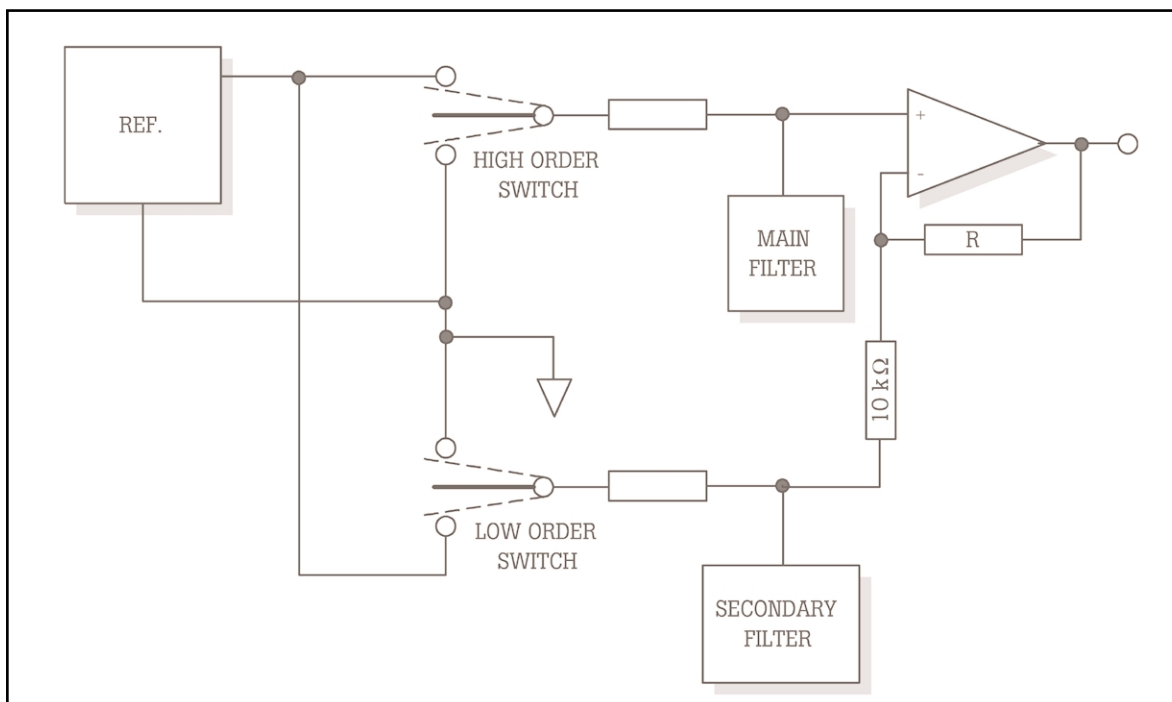

Fig. 3 Two stage PWM circuit

The output is then passed through a multi-stage, low pass filter network, capable of eliminating all ripple and noise content, and thus providing a highly stable and linear output voltage. The output voltage can be expressed using the formula: $V_o = V_{IN} \times X/n$

The ratio divider criterion in a calibrator is consequently set by the frequency of the control clock driving the two FETs.

As with any ratio divider, the PWM technique operates on the basis of 'dimensionless' ratio. That is, there are no absolute quantities involved that are subject to change over time offering very repeatable linearity dependent only upon an extremely reliable digital clocking waveform. To further maintain high confidence, linearity is subsequently verified during artifact calibration. This approach compares the same two fixed voltages, V_1 and V_2 , on different ranges. Figure 5 illustrates this comparison. If the PWM is perfectly linear, then $N_4/N_3 = N_2/N_1$.

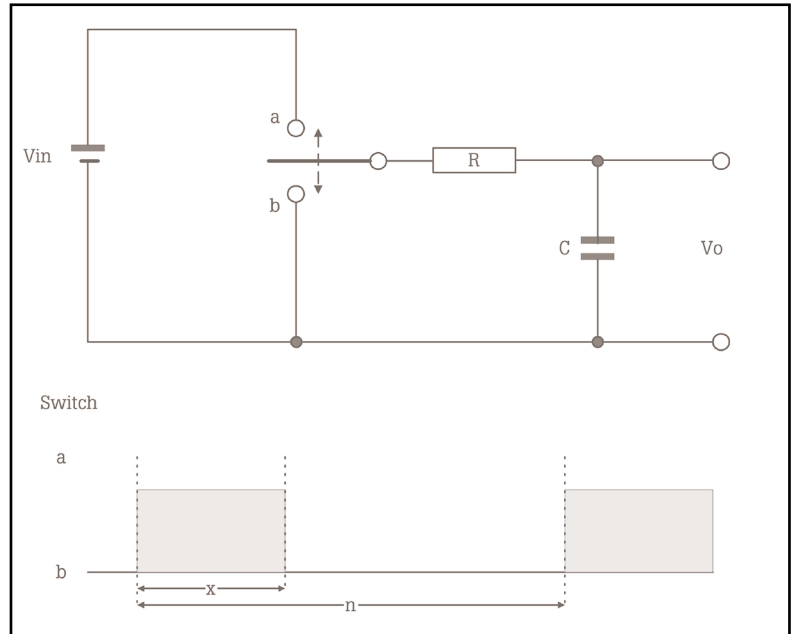

Fig. 4 A representation of the output voltage prior to filtering

The development of artifact calibration

Artifact calibration is a process where calibrators automatically perform internal ratiometric comparisons and store the correction data relative to a few precise external artifact standards.

Traditionally these comparisons were performed using an assortment of ratio measuring equipment to achieve this. However, over the last twenty years, instruments with artifact calibration capability have all but eliminated many of these labor-intensive measurement tasks. Many traditional manual operations to establish voltage, resistance or current ratios can now be accomplished automatically within the instrument, consequently providing consistent and efficient calibrations, as well as significantly reducing the costs previously associated with higher labor intensity and a larger equipment inventory.

Fundamentally, an instrument with artifact calibration capabilities will first transfer and then reference to a set of external artifact voltage and resistance standards. Having been transferred, this internal voltage reference can then be configured to appear as if it had been applied to an internal array of comparable instruments like a Kelvin-Varley divider, a null detector or even a decade divider, though in practice this is not really the case.

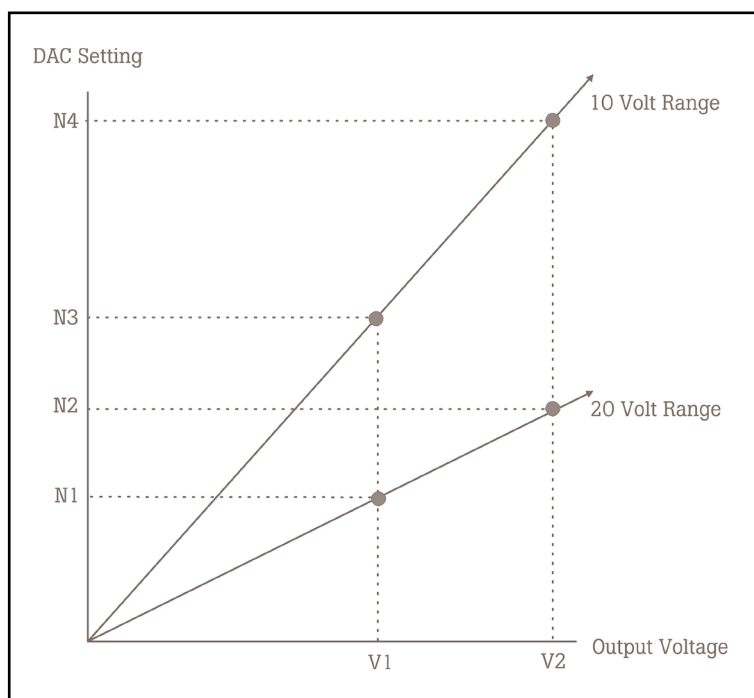

Fig. 5 Converter linearity verification

Technology advances have shrunk the null detector onto a miniature hybrid integrated circuit, the ratio system is now a single PWM printed circuit board, and improved lower cost thin film resistor networks have replaced bulky wire-wound resistor ratios. This kind of advance in technology now means that designers can produce highly comprehensive instruments with artifact calibration capability. So now, having eliminated these extra external devices and mimicked the same capability from within the instrument, we can now transfer the accuracy of the artifact to the various ranges of the instrument with minimal uncertainty, with greater accuracy and stability, and with complete traceability.

The dawning of the high resolution DMMs

As discussed earlier, artifact calibration is a particularly efficient and easy method of carrying out a multitude of calibrations. However, while being an acceptable method of calibration, it does come at a price. Therefore, artifact technology is normally found on calibrators at the premium end of the range.

While lower performance, less accurate calibrators forego artifact design, adopting more traditional direct function-to-function, range-to-range verification.

Even with artifact calibration, it has been generally recommended by all manufacturers to fully verify each range using external methods at least twice in its first year, and then subsequently every two years. It is this reason that many laboratories would, and in some cases still do, resort to more traditional calibration systems, like the Fluke 7105A or Datron 4900, to accomplish this.

Today, most laboratories with a large installed base of calibrators carry out the process of their verifications using high resolution digital multimeters like the Fluke 8508A Reference multimeter. These meters can be used to perform all of the functions previously associated with the older calibration systems with little or no degradation of uncertainties. Another real benefit with using these meters comes from the considerable reduction with inter-connection leads and the immense time saved to re-configure the setup for a different measurement.

Add to this the ability to fully automate the calibration process, and the reference multimeter becomes very easy to justify over most of the traditional systems.

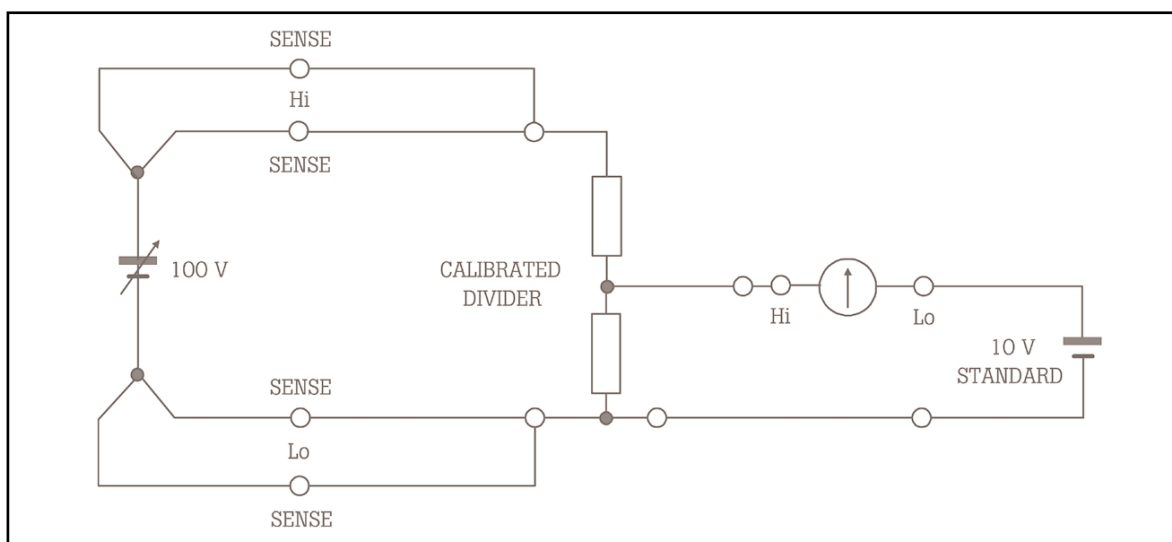

Fig. 6 An example of a Fluke 7105A or datron 4900 voltage calibration system

Calibrating the calibrator before the days of long-scale DMMs

The advantages of using a single high resolution DMM over the traditional multi-instrument calibration systems are probably best demonstrated by firstly describing how a typical calibration would have been carried out. Figure 6 illustrates the source calibrator (UUT), an external divider, null detector and a 10 V dc reference in a conventional voltage calibration setup.

Here the 100 V dc source (UUT) is being verified against a 10 V reference, using a ratio divider of 10:1. In reality the ratio divider would have several 'taps' calibrated to a set of definitive ratios i.e. 100:1, 10:1, 1:1 V and 0.1:1 V. Before any verification of voltage could take place, the individual ratios would have first been calibrated separately so that the given ratios exactly represented the source instrument's output voltage at each voltage step. The possibility of drift with time, due to the temperature

coefficient of the ratio resistors, meant that this process would have required a skilled metrologist who knew how to perform this operation both competently and promptly. Having calibrated the divider, the UUT calibrator could now be connected as described in figure 6. With a null detector between the ratio divider and 10 V dc reference, the source calibrator would now be adjusted until the null detector indicator displayed zero. (Any residual error would contribute to the expanded uncertainty.)

From this brief description, you can probably begin to comprehend how complex this particular measurement process is. In addition, the lack of any kind of remote capability, the time consuming makeup of the procedure and, above all, the overall cost of the system, only serves to further compound the situation. Nonetheless, advances in technology, coupled with the need to make the methodology simpler, faster, cheaper and more efficient, help set a new precedent within the industry.

Early precision high resolution DMMs like the Fluke 8505/8506 consolidated the methods used by all of the test devices illustrated in figure 6 into a single instrument, so eliminating most interconnecting lead errors, greatly reducing the overall cost of the calibration system, but moreover, allowing full automation of virtually all measurement tasks. This in turn liberated the senior metrologist from this task and allowed him/her to concentrate on other important laboratory responsibilities.

Reference multimeter with reference standard accuracy and stability

High resolution precision DMMs have been available for almost thirteen years, but since their launch in the late 1980s the products have remained comparable in both performance and application. Since Fluke's acquisition of precision instrument manufacturer Wavetek-Datron in 2000, design teams in the US and UK have worked together and pooled their expertise to produce the best in precision and long-scale DMM design - The Fluke 8508A Reference Multimeter. The 8508A has taken many of the leading Fluke and Wavetek-Datron patented multimeter designs and then improved them further, using the latest state of the art technology and new electronic measurement design techniques.

For the example given in Figure 6, the Fluke 8508A eliminates every instrument other than the 10 V reference. In essence, the function of both the ratio divider network and null detector has now been replicated into the 8508A.

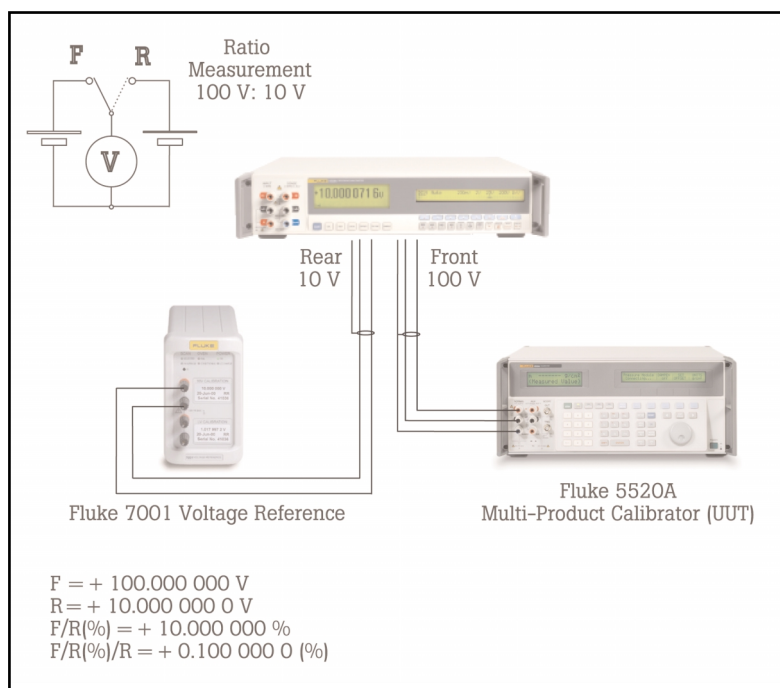

Fig. 7 An example of the reference multimeter being used to accurately verify the output of the artifact calibrator to a known voltage reference

Furthermore, all inter-connecting leads that existed between these two instruments have also been eradicated, removing the probability of lead errors and consequently the need to compensate for these errors. Having connected the 10 V reference to the Fluke 8508A's second input channel (rear input), the 100 V dc from the UUT being standardized can then be applied to the 8508A's front input channel. This is typically done as shown in figure 7. The 8508A Reference Multimeter has two input channels that can be automatically switched to perform a ratio measurement. The 10 V reference would be connected to the 8508A's rear input (channel B), with the UUT's 100 V dc voltage connected to the 8508A's front input (channel A). In Ratio mode, the 8508A displays the ratio of the inputs in the form F-R (front minus rear), or F/R (front as a percentage of the rear), or (F-R)/R (the difference as a percentage of the rear). In the example given, the F/R (i.e. the front as a percentage of the rear) mode would be used. In this mode, with the 10 V dc reference connected to the rear channel and 100 V connected to the front channel, the display would show +10.000 000 %. This is the ratio of the unknown 100 V to the known 10 V reference. Note that the reference multimeter is measuring the whole voltage for each channel and is configured to a single dc voltage range (200 V). Consequently, the only significant error contributions to this measurement are the uncertainty of the 10 V reference standard, the noise and differential linearity of the reference multimeter and the noise of the UUT 100 V standard.

Typical noise of the reference multimeter is less than 50 nV pk/pk (7½ Normal & 8½ Fast ADC modes) with the differential linearity in 8½ digit mode being better than 0.1 ppm of range over a value ranging from 10 V to 1 V (halve the typical linearity spec for values spanning the entire DMM scale from 0 to 19.99999 V). Note: the above procedure assumes that the 10 V dc reference standard being used is calibrated and has an assigned value. The assigned value is keyed into the 8508A math memory subsequently correcting any residual gain error on the multimeters 20 V range.

Typical procedure sequence:

- 1) Select DCV 20 V range
- 2) Connect low thermal cables to the 8508A front and rear terminals (8508A-LEAD).
- 3) Short the Front A and Rear B inputs at the cable ends of the 8508A and perform zero range function.
- 4) Remove shorts and connect calibrator to 8508A front input.
- 5) Connect 10 V reference standard (e.g. Fluke 732B) to 8508A rear input.
- 6) Configure 8508A, rear input, rolling average, 16 samples, 8.5 digits, and record reference reading after initiating a two-minute delay.
- 7) Select math mode, deselect rolling average, enter the reference standard value (as recorded in step 6) into the 8508A "m" variable.
- 8) Select scan, F/R and allow two minutes for stabilization.
- 9) Select Math *m.
- 10) The 8508A will now perform the ratio reading, multiply it by the traceable reference standard value and display the UUT normalized value on the front display.
- 11) It is recommended that after approximately 10 averaged readings have been recorded, refer back to step #4 to regain a new reference point.

The uncertainty associated with this measurement is similar to that which might be obtained by a skilled metrologist with a newly calibrated voltage divider and a null detector. In addition, the reference multimeter can make this measurement for prolonged periods, as its linearity does not change significantly over time.

Uncertainty components.

- 1) DMM short term stability when measuring 100 V.
- 2) DMM short term stability when measuring 10 V.
- 3) DMM linearity.

The 8508A specifications detail the uncertainty for the DMM as: 10 V measured on the 200 V range to eliminate range switching using 20 minute transfer specification = 0.4 ppm of Reading + 0.1 ppm of range RSS above result with 100 V measured on the 200 V range using similar transfer specification and the total measurement uncertainty is approximately 2.5 ppm of Ratio.

The 0.4 ppm of reading accounts for noise and 0.1 ppm of range accounts for a conservative linearity specification. Therefore as two individual measurements are being performed during ratio mode the transfer specification for each measurement is RSS'd together yield a measurement uncertainty of 2.5 ppm of Ratio reading. Some additional uncertainty maybe considered for the source.

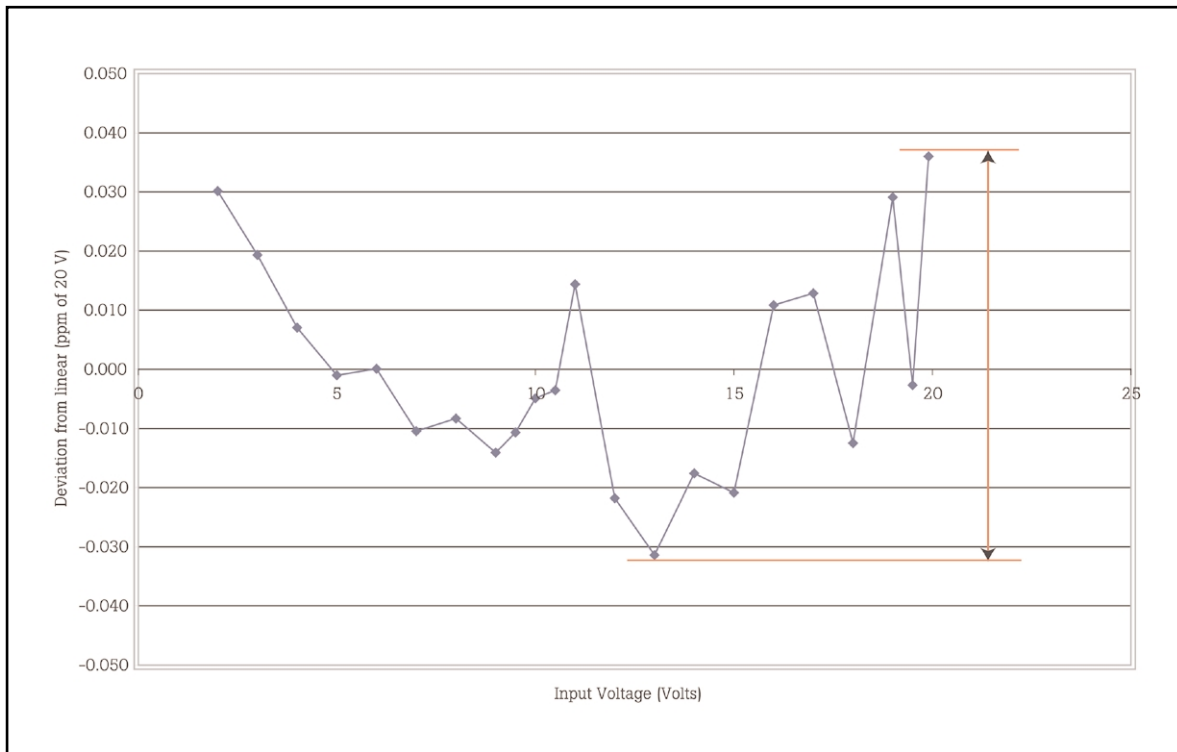

Fig. 8 A typical example of type testing linearity on the Fluke 8508A

A conservative linearity specification is assigned to multimeters during development as part of type testing. The specification supports a worst case linearity measurement which is often at the two extremes of a range. In practice this spec is often very conservative, an example would be to compare a known (traceable) 10 V with unknown 10 V standard on a fixed range - what is the linearity spec? In this example there is negligible contribution to linearity as each measurement is being made at the same point in a given range. Linearity measurements could be performed on every multimeter to yield better specs. However, who should determine how many points are measured to gain confidence? This exercise is time consuming and requires extremely low measurement uncertainty often only achievable using JJ Array standards.

Figure 8 shows an example of type testing linearity on the 8508A multimeter. The graph indicates deviation in ppm of range at various points on the multimeters +20 V range. A published spec of 0.2 ppm of range is assigned, yet type testing results in better than ± 0.035 ppm of range as indicated by the two extremes of deviation from the ideal linearity.

Summary

In summary, a comparison of measurement uncertainty between divider system and 8508A will often favor the traditional divider systems. However the improvements in measurement uncertainty will be at a cost!

Uncertainty may be compromised using modern instrumentation, but further consideration must be given to the intended application and how it may have changed.

Precision calibrators once required divider type measurement uncertainty now implement artifact calibration. Where linearity verification is involved divider technology is now internal to the calibrator design. This is not true of all calibrators where linearity measurement using multimeter performance remains adequate for lower priced, less accurate calibrators.

Ordering information

Model

8508A
8508A/01

8.5 digit Reference Multimeter, Certificate of Calibration and User Manual
8.5 digit Reference Multimeter with front & rear input binding posts, Certificate of Calibration and User Manual

Accessories

NVLAP	NVLAP Accredited Calibration
UKAS	UKAS Accredited Calibration
8508A-SPRT	Standard Platinum Resistance Thermometer
8508A-PRT	100 Ω PRT
8508A-LEAD	Comprehensive Measurement Lead Kit
Y8508	Rack Mount Kit
Y8508S	Rack Mount Kit Slides
8508-7000K	Calibration Kit

Other precision instruments in the range

5720A Multifunction Calibrator



The lowest uncertainties of any multifunction calibrator

525A Temperature/Pressure Calibrator



Superior accuracy and functionality in an economical benchtop package

9500B Oscilloscope Calibrator



High accuracy calibration of analog and digital-storage oscilloscopes up to 3.2 and 6 GHz

Fluke 8508A Reference Multimeter



Reference standard accuracy and stability, in one functionally versatile, easy to use solution

Fluke. *Keeping your world up and running.*

Fluke Corporation
PO Box 9090, Everett, WA USA 98206

Fluke Europe B.V.
PO Box 1186, 5602 BD
Eindhoven, The Netherlands

For more information call:
In the U.S.A. (800) 443-5853 or
Fax (425) 446-5116

In Europe/M-East/Africa (31 40) 2 675 200 or
Fax (31 40) 2 675 222
Canada (800)-36-FLUKE or
Fax (905) 890-6866

From other countries +1 (425) 446-5500 or
Fax +1 (425) 446-5116

Web access: <http://www.fluke.com/>

©2003 Fluke Corporation. All rights reserved.
Trademarks are the property of their respective owners.
Printed in UK 10/2003 2114953 D-ENG-N Rev A, DS271