

## Viscount<sup>®</sup> II Pump

307160R

*1500 psi (10.3 MPa, 103 bar) Maximum Hydraulic Input Pressure*

*1000 psi (7 MPa, 69 bar) Maximum Pump Outlet Pressure*

### **Model 210313, Series D**

With Severe-Duty Displacement Pump\*

\* Severe-Duty displacement pumps have an abrasion and corrosion-resistant displacement rod and cylinder. Refer to the Technical Data section of the separate pump manual for “Wetted Parts” information.



**Read warnings and instructions.**

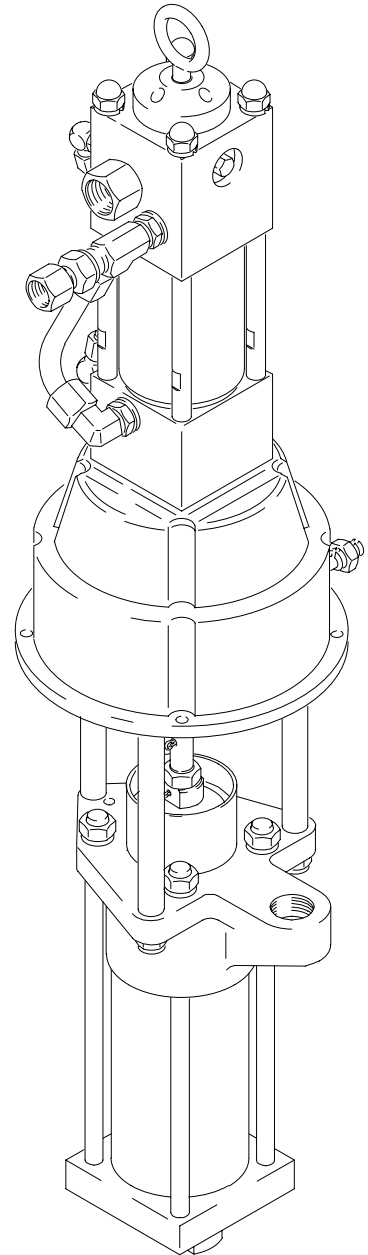

PROVEN QUALITY. LEADING TECHNOLOGY.

# Table of Contents

Warnings .....	2	Dimensions .....	14
Installation .....	5	Mounting holes .....	14
Operation .....	8	Performance Charts .....	15
Maintenance .....	10	Technical Data .....	15
Troubleshooting .....	11	Graco Standard Warranty .....	16
Service .....	12	Graco Information .....	16
Parts .....	13		

## Symbols

### Warning Symbol



This symbol alerts you to the possibility of serious injury or death if you do not follow the instructions.

### Caution Symbol



This symbol alerts you to the possibility of damage to or destruction of equipment if you do not follow the instructions.

## ! WARNING



### EQUIPMENT MISUSE HAZARD

Equipment misuse can cause the equipment to rupture or malfunction and result in serious injury.

- This equipment is for professional use only.
- Read all instruction manuals, tags, and labels before operating the equipment.
- Use the equipment only for its intended purpose. If you are not sure, call your Graco distributor.
- Do not alter or modify this equipment.
- Check equipment daily. Repair or replace worn or damaged parts immediately.
- Do not exceed the maximum working pressure stated on the equipment or in the **Technical Data** for your equipment. Do not exceed the maximum working pressure of the lowest rated component in your system.
- Use fluids and solvents which are compatible with the equipment wetted parts. Refer to the **Technical Data** section of all equipment manuals. Read the fluid and solvent manufacturer's warnings.
- Handle hoses carefully. Do not pull on hoses to move equipment.
- Route hoses away from traffic areas, sharp edges, moving parts, and hot surfaces. Do not expose Graco hoses to temperatures above 66°C (150°F) or below -40°C (-40°F).
- Wear hearing protection when operating this equipment.
- Do not move or lift pressurized equipment.
- Comply with all applicable local, state, and national fire, electrical, and safety regulations.

# WARNING

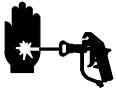

## INJECTION HAZARD

Spray from the gun/valve, leaks or ruptured components can inject fluid into your body and cause extremely serious injury, including the need for amputation. Fluid splashed in the eyes or on the skin can also cause serious injury.

- Fluid injected into the skin might look like just a cut, but it is a serious injury. Get immediate medical attention.
- Do not point the gun/valve at anyone or at any part of the body.
- Do not put your hand or fingers over the spray tip/valve nozzle.
- Do not stop or deflect leaks with your hand, body, glove or rag.
- Do not “blow back” fluid; this is not an air spray system.
- Always have the tip guard and the trigger guard on the gun/valve when spraying/dispensing.
- Be sure the gun/valve trigger safety operates before spraying/dispensing.
- Lock the gun/valve trigger safety when you stop spraying/dispensing.
- Follow the **Pressure Relief Procedure** on page 8 if the spray tip clogs and before cleaning, checking or servicing the equipment.
- Tighten all fluid connections before operating the equipment.
- Check the hoses, tubes, and couplings daily. Replace worn, damaged, or loose parts immediately. Permanently coupled hoses cannot be repaired; replace the entire hose.



## MOVING PARTS HAZARD

Moving parts can pinch or amputate your fingers.

- Keep clear of all moving parts when starting or operating the pump.
- Before checking or servicing the equipment, follow the **Pressure Relief Procedure** on page 8 to prevent the equipment from starting unexpectedly.

# WARNING



## FIRE AND EXPLOSION HAZARD

Improper grounding, poor ventilation, open flames or sparks can cause a hazardous condition and result in a fire or explosion and serious injury.



- Ground the equipment and the object being sprayed. Refer to **Grounding** on page 5.
- If there is any static sparking or you feel an electric shock while using this equipment, **stop spraying/dispersing immediately**. Do not use the equipment until you identify and correct the problem.
- Provide fresh air ventilation to avoid the buildup of flammable fumes from solvents or the fluid being sprayed/dispensed.
- Keep the spray/dispense area free of debris, including solvent, rags, and gasoline.
- Before operating this equipment, electrically disconnect all equipment in the spray/dispense area.
- Before operating this equipment, extinguish all open flames or pilot lights in the spray/dispense area.
- Do not smoke in the spray/dispense area.
- Do not turn on or off any light switch in the spray/dispense area while spraying/dispersing or while operating if fumes are present.
- Do not operate a gasoline engine in the spray/dispense area.



## TOXIC FLUID HAZARD

Hazardous fluid or toxic fumes can cause serious injury or death if splashed in the eyes or on the skin, inhaled, or swallowed.

- Know the specific hazards of the fluid you are using.
- Store hazardous fluid in an approved container. Dispose of hazardous fluid according to all local, state and national guidelines.
- Always wear protective eyewear, gloves, clothing and respirator as recommended by the fluid and solvent manufacturer.

# Installation

## General Information

**NOTE:** Reference numbers and letters in parentheses in the text refer to the callouts in the figures and the parts drawing.

**NOTE:** Always use Genuine Graco Parts and Accessories, available from your Graco distributor.

## Grounding

**⚠ WARNING**

**FIRE AND EXPLOSION HAZARD**  
Before operating the pump, ground the system as explained below. Also read the section **FIRE OR EXPLOSION HAZARD** on page 4.



- **Pump:** Use a ground wire and clamp as shown in Fig. 1. Loosen the grounding lug locknut (W) and washer (X). Insert one end of a 12 ga (1.5 mm<sup>2</sup>) minimum ground wire (Y) into the slot in lug (Z) and tighten the locknut securely. Connect the other end of the wire to a true earth ground. Order part number 237569 Grounding Clamp and Wire.
- **Fluid and hydraulic hoses:** Use only grounded hoses with a maximum of 500 ft (150 m) combined hose length to ensure grounding continuity.
- **Hydraulic Power Supply:** Follow the manufacturer's recommendations.

- **Spray gun:** Ground through connection to a properly grounded fluid hose and sprayer.
- **Object being sprayed:** Follow the local code.
- **Fluid supply container:** Follow the local code.
- **Solvent pails used when flushing:** Follow the local code. Use only metal pails, which are conductive, placed on a grounded surface. Do not place the pail on a nonconductive surface, such as paper or cardboard, which interrupts the grounding continuity.
- **To maintain grounding continuity when flushing or relieving pressure,** hold a metal part of the spray gun firmly to the side of a grounded *metal* pail, then trigger the gun.

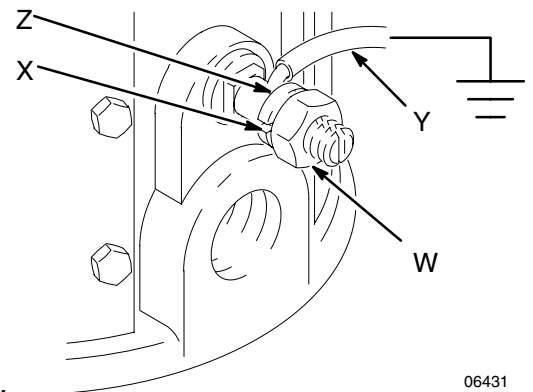

Fig. 1

06431

# Installation

Mount the pump to suit the type of installation planned. Pump dimensions and mounting hole layout are shown on page 14.

## CAUTION

The hydraulic supply system must be kept clean at all times to avoid damage to the motor and hydraulic power supply. Blow out all hydraulic lines with air and flush thoroughly with compatible solvent before connecting the lines to the motor.

Always plug the hydraulic inlets, outlets, and lines when disconnecting them for any reason, to avoid introducing dirt and other contaminants into the system.

## Filters

Be sure that your hydraulic power supply is equipped with a suction filter to the hydraulic pump and a system return line filter of 10 micron size.

Carefully follow the manufacturer's recommendations on reservoir and filter cleaning, and periodic changes of hydraulic fluid. Use only Graco-approved hydraulic oil.

## Hydraulic Lines

Connect a 3/4 in. minimum ID hydraulic supply line (L) to the 3.4 npt inlet of the hydraulic motor. See the Typical Installation on page 7. Connect a 1 in. minimum ID return line (D) to the 1" npt return port on the hydraulic motor.

On the hydraulic supply side (C), install the following accessories shown in Fig. 2, using adapters as necessary.

- **A shutoff valve (E)** isolates the pump for service.
- **A fluid pressure gauge (F)** to monitor hydraulic oil pressure to the motor and to avoid overpressurizing the motor or displacement pump, and **a pressure- and temperature-compensated flow control valve (G)** to prevent the motor from running too fast and possibly damaging itself.

- **A pressure reducing valve (H), with a drain line (K)** running directly to the hydraulic return line (D).
- **An accumulator (J)** to reduce the hammering effect caused by the motor reversing direction.
- **A shutoff valve (E)** isolates the pump for service.

## CAUTION

Do not exceed 10 gpm (37.8 liter/minute) volume to avoid pump stalling.

## Drip Pan

The hydraulic motor is equipped with a drip pan to collect any leakage that might occur. connect a 1/4 in. ID drain hose (Q) to the barbed hose fitting on the drip pan.

## Drain Valve

Install a high pressure fluid drain valve (B) near the pump fluid outlet to relieve fluid pressure in the displacement pump and hose during shutdown.

## WARNING

The fluid drain valve (B) is required in your system to help reduce the risk of serious bodily injury, including fluid injection and splashing in the eyes or on the skin if you are adjusting or repairing any part of the system. Triggering the gun to relieve pressure may not be sufficient.

## Fluid Supply Lines

Connect a grounded fluid supply line to the 1–1/2" npt fluid outlet on the displacement pump. Attach a fluid supply line to the 2" npt pump fluid intake.

If you are pumping through a long hose, or if the fluid being pumped is compressible, giving an accumulator effect, install a check valve at the pump outlet. Be sure that the check valve selected is capable of handling the flow and pressure developed in your system.

# Installation

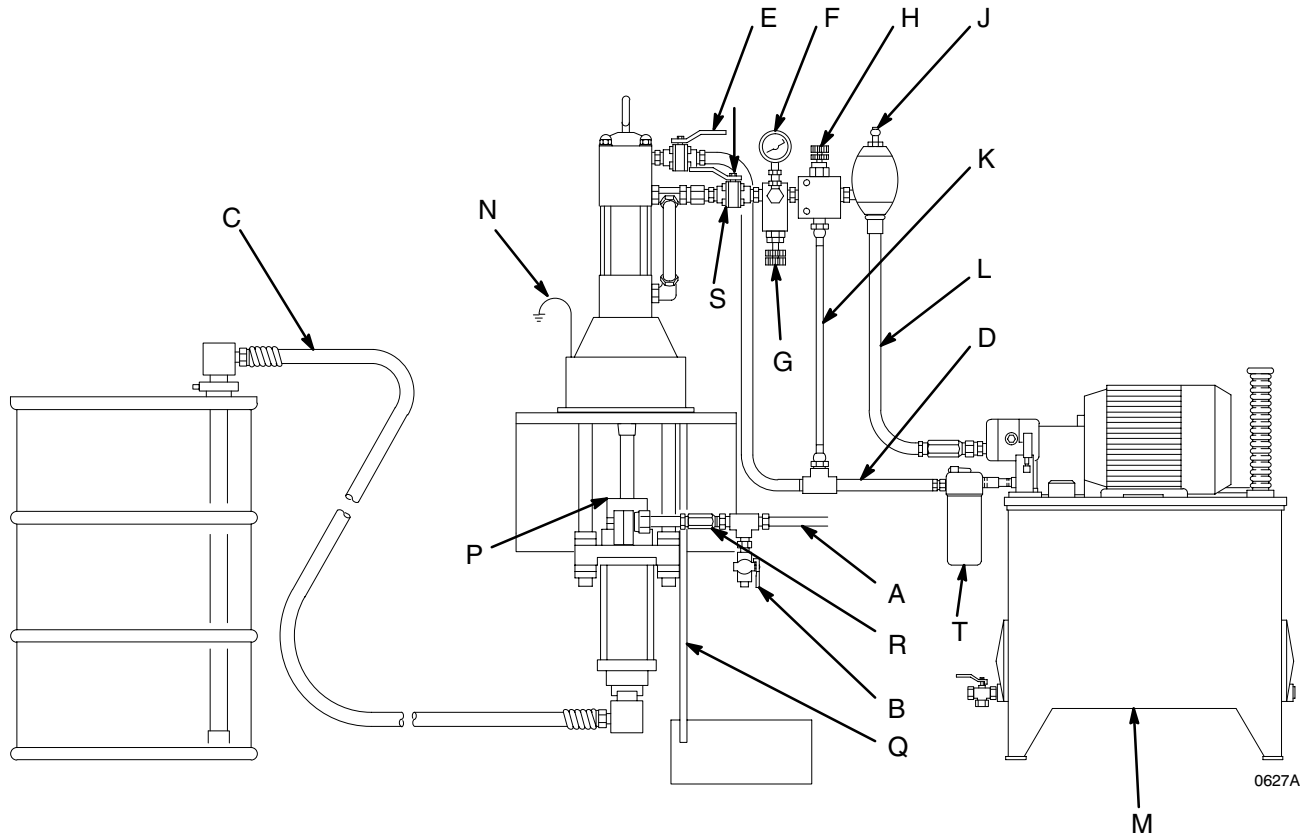

**KEY**

- |   |  |
|---|--|
| <b>A</b> Fluid Hose to Gun              | <b>K</b> Drain Line (from pressure reducing valve) |
| <b>B</b> Fluid Drain Valve              | <b>L</b> Hydraulic Supply Line                     |
| <b>C</b> Suction Hose                   | <b>M</b> Hydraulic Power Supply                    |
| <b>D</b> Hydraulic Return Line          | <b>N</b> Ground Wire                               |
| <b>E</b> Hydraulic Return Shutoff Valve | <b>P</b> Wet-Cup                                   |
| <b>F</b> Pressure Gauge                 | <b>Q</b> Drain Line (from motor drip pan)          |
| <b>G</b> Flow Control Valve             | <b>R</b> Check Valve                               |
| <b>H</b> Pressure Reducing Valve        | <b>S</b> Hydraulic Supply Shutoff Valve            |
| <b>J</b> Accumulator                    | <b>T</b> Return Line Filter                        |

**Fig. 2**

# Operation

## Pressure Relief Procedure

### **WARNING**



#### **INJECTION HAZARD**

Fluid under high pressure can be injected through the skin and cause serious injury. To reduce the risk of an injury from injection, splashing fluid, or moving parts, follow the **Pressure Relief Procedure** whenever you

- Are instructed to relieve the pressure
- Stop spraying/dispensing
- Check or service any of the system equipment
- Install or clean the spray tips/nozzles

1. Engage the safety latch.
2. Shut off the power supply to the hydraulic motor.
3. Disengage the gun safety latch.
4. Hold a metal part of the gun firmly to the side of a grounded metal pail. Trigger to relieve pressure.
5. Open the fluid drain valve (required in your system) having a container ready to catch the drainage. Leave the drain valve open until you are ready to spray again.

*If you suspect that the spray tip or hose is completely clogged, or that pressure has not been fully relieved after following the steps above, **very slowly** loosen the tip guard retaining nut or hose end coupling and relieve pressure gradually, then loosen completely, then clear the tip or hose.*

### **CAUTION**

When shutting down the hydraulic system, always shut off the hydraulic supply line shutoff valve (S) first, and then the return line shutoff valve (E). This is to prevent overpressurizing the motor or its seals. When starting the hydraulic system, open the return line shutoff valve first.

## Flushing the Pump

Flush the pump before using it for the first time to remove the lightweight oil which is left in the pump after factory testing to protect it from corrosion. Be sure the solvent used is compatible with the fluid to be sprayed, and with the wetted parts of the pump. Refer to the Technical Data in the separate displacement pump manual for the wetted parts. Flush until clean solvent comes from the gun. In a circulating system, flush long enough to clean the entire system.



# Operation

## WARNING

### COMPONENT RUPTURE HAZARD



To reduce the risk of overpressurizing your system, which could cause component rupture and serious injury, *never exceed the specified Maximum Hydraulic Input Pressure to the pump* (see the **Technical Data** on page 15).

To prevent overpressurizing the hydraulic motor or its seals, always shut off the supply line valve (S) *first*, then shut off the return line valve (E).

## Starting and Adjusting the Pump

## WARNING

To reduce the risk of serious injury whenever you are instructed to relieve pressure, always follow the **Pressure Relief Procedure** on page 8.

**NOTE:** If the pump is not immersed in fluid, fill the wet-cup (P) 1/3 full with Graco Throat Seal Liquid (TSL) or a compatible solvent, to prevent fluid from drying on the displacement rod and damaging the pump packings. Refer to the Typical Installation on page 7. Check the tightness of the packing nut/wet-cup weekly. Before adjusting, **relieve the pressure**. The nut should be tight enough to prevent leakage, but no tighter.

Check the hydraulic fluid level, and add fluid as necessary to the fill lines, before each use. Turn on the hydraulic power supply. Open the return line shutoff valve (E). Slowly open the hydraulic supply shutoff valve (S). Run the pump slowly until all air is pushed out of the lines and fluid is flowing smoothly. Close the spray gun; the pump will stall. Use the lowest pressure possible to get the desired results. Higher pressures will cause premature tip and pump wear.

**NOTE:** In a direct supply system, the pump starts and stops automatically when the spray gun is opened and closed. In a circulating system, the pump runs continuously, speeding up or slowing down as the spray gun is opened or closed, until the hydraulic power supply is turned off.

## CAUTION

Never allow the hydraulic oil temperature to exceed 130° F (54° C). The pump seals will wear faster and leaking may occur at higher temperatures.

## WARNING

To reduce the risk of overpressurizing the system, always follow these precautions:

Never exceed 1500 psi (10.3 MPa, 103 bar), or 10 gpm (37.8 liter/min) hydraulic input to the motor.

Never exceed 1000 psi (7 MPa, 69 bar) maximum pump outlet pressure.

## Check Valve Adjustment

The fluid piston and intake valve are factory set for high-volume pumping of heavy, spray-viscosity fluids. To adjust the check valves, refer to the operation section in the separate displacement pump manual.

# Maintenance

Carefully monitor your fluid supply. If your pump is running too fast, or accelerates quickly, it is probably out of fluid. Shut off the hydraulic power supply immediately to prevent damage to the pump. If the fluid supply is empty, and air has entered the fluid lines, be sure to prime the pump again before regular operation.

Flush the pump frequently enough to prevent the fluid from drying or settling in the pump and hoses to prevent costly damage. Use a compatible solvent. Refer to the Technical Data in the separate displacement pump manual for a list of the wetted parts.

If you are pumping water-base fluid, first flush with water and then with a compatible solvent.

## Corrosion Protection

### **WARNING**

To reduce the risk of serious injury whenever you are instructed to relieve pressure, always follow the **Pressure Relief Procedure** on page 8.

### **CAUTION**

To help prevent corrosion of the pump, never leave the pump filled with water or water-base fluids, or air during non-use. After flushing, flush the pump again with a compatible solvent, such as mineral spirits, **relieve the pressure**, and leave a coating of solvent in the pump and hoses..

## Shutdown

### **WARNING**

To reduce the risk of serious injury whenever you are instructed to relieve pressure, always follow the **Pressure Relief Procedure** on page 8.

Always stop the pump with the displacement rod in the down position. This prevents fluid from drying on the displacement rod and damaging the packings when the pump is restarted. **Relieve the pressure** whenever you shut off the pump.

# Troubleshooting

## WARNING

To reduce the risk of serious injury whenever you are instructed to relieve pressure, always follow the **Pressure Relief Procedure** on page 8.

Before servicing this equipment, always make sure to **relieve the pressure**.

**NOTE:** Check all possible problems and solutions before disassembling the pump.

Problem	Cause	Solution
Pump fails to operate	Restricted lines or inadequate hydraulic supply	Clear lines. Increase hydraulic supply.
	Insufficient hydraulic pressure; closed or clogged valves, etc.	Open; clean.
	Exhausted fluid supply	Refill and reprime, or flush.*
	Clogged fluid line, valves, etc.	Clear.**
	Damaged hydraulic motor	Service the motor. See manual 307158
	Dried fluid seizure of displacement rod.	Clean. See Displacement pump manual 308043. Also, keep TSL in the pump wet-cup and stop the pump at the bottom of its stroke during non-use.
Pump operates, but the fluid output is low on both strokes	Restricted lines, or inadequate hydraulic supply	Clear lines. Increase hydraulic supply.
	Insufficient hydraulic pressure; closed or clogged valves, etc.	Open; clean.
	Exhausted fluid supply	Refill and reprime or flush.*
	Clogged fluid line, valves, etc.	Clear.**
	Piston check valve needs adjustment	Adjust. See manual 308043.
	Packing nut too tight	Loosen.
	Loose packing nut or worn throat packings.	Tighten packing nut or replace packings as needed, See manual 308043.
Pump operates, but the output is low on the downstroke	The intake valve is stuck open or worn.	Clear; service. See manual 308043.
Pump operates, but the output is low on the upstroke	The piston valve is stuck open, or the packings are worn	Clear; service. See manual 308043.
Pump is operating erratically, or speeds up suddenly	Exhausted fluid supply	Refill and reprime or flush.*
	The intake valve is stuck open or worn	Check; replace parts as needed. See manual 308043.
	The piston valve is stuck open or the packings are worn.	Check; replace parts as needed. See manual 308043.
	Excessive hydraulic fluid supply volume	Lower volume.
	Air entrained in fluid	Purge all air; change fluid.

\* Stop the pump immediately if it is running too fast; check the fluid supply. If empty, refill and reprime the pump being sure to eliminate all air from the system, or flush the pump and store it with an oil-based solvent, such as mineral spirits, to prevent corrosion.

\*\* **Relieve the pressure**, and then disconnect the fluid line. If the pump starts when the hydraulic power is re-stored, line, etc. is clogged.

# Service

**NOTE:** To service the displacement pump, refer to manual 308043, supplied.

**NOTE:** To service the hydraulic motor, refer to manual 308158, supplied.

 Torque to 40–50 ft-lb (54–68 N•m)

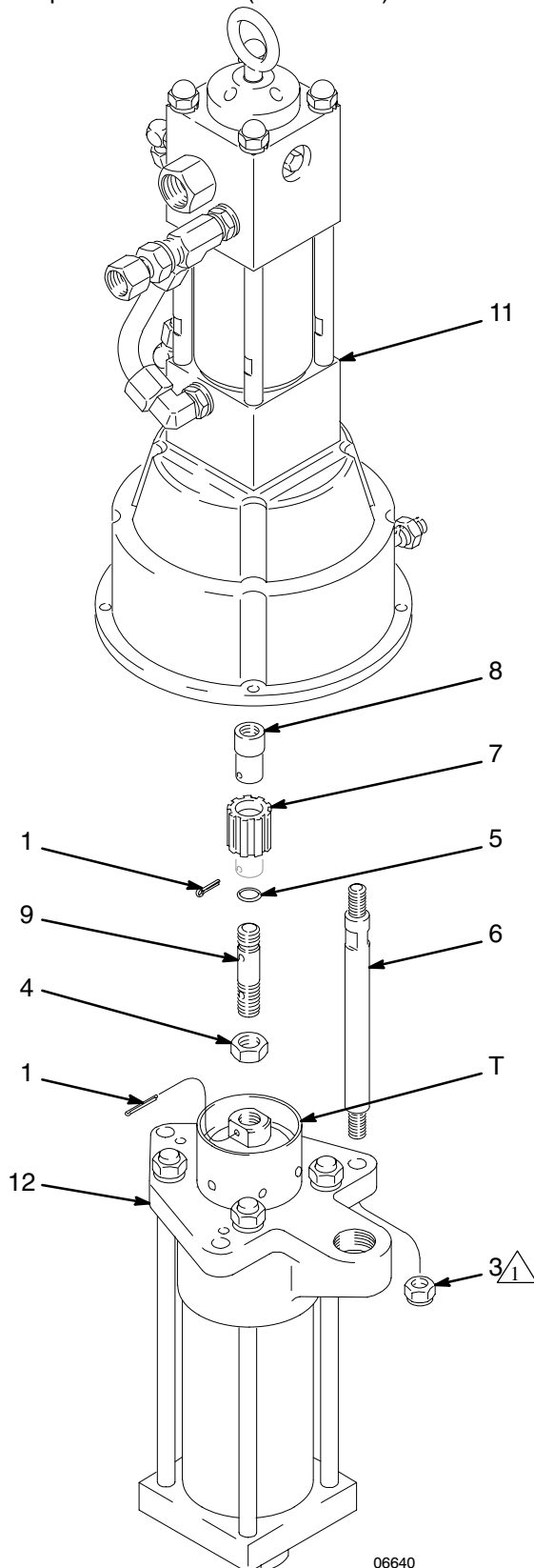

## Disassembly (See Fig. 3)

### **WARNING**

To reduce the risk of serious injury whenever you are instructed to relieve pressure, always follow the **Pressure Relief Procedure** on page 8.

1. Flush the pump with a compatible solvent, if possible. Stop the pump at the bottom of its stroke. **Relieve the pressure.**
2. Disconnect the hoses from the pump. Plug the hydraulic lines to prevent contamination. Remove the pump from its mounting and clamp it in a vise.
3. Remove the upper cotter pin (1). Unscrew the coupling nut (7). Unscrew the three tie rod locknuts (3), then unscrew the three tie rods (6) from the hydraulic motor (11). Carefully pull the displacement pump (12) away from the motor (11).
4. Remove the lower cotter pin (1). Loosen the locknut (4). Unscrew the connecting rod (9) from the displacement rod (T).

## Reassembly (See Fig. 3)

1. Screw the three tie rods (6) into the motor (11). Torque to 40–50 ft-lb (54–68 N•m).
2. Screw the connecting rod (9) into the displacement rod (T). Install the cotter pin (1) and tighten the locknut (4).
3. Guide the displacement pump (12) onto the tie rods (6).
4. Install the locknuts (3) on the tie rods. Torque the nuts to 40–50 ft-lb (54–68 N•m).
5. Tighten the coupling nut (7). Insert the upper cotter pin (1) through the coupling (8)
6. Connect the hoses to the pump. Run the pump slowly to be sure it runs smoothly and does not bind. If necessary, adjust the displacement pump tie rods and locknuts (see manual 308043), or the tie rods (6) and locknuts (3) which attach the motor, to eliminate binding.
7. Reconnect the ground wire to the motor.

Fig. 3

06640

# Parts

Ref. No.	Part No.	Description	Qty.
1	100103	PIN, cotter; 1.5" (38.1 mm) long	2
3	101712	LOCKNUT; 5/8-11; with nylon insert	3
4	101936	NUT, hex, jam; 3/4-10	1
5	158674	O-RING; nitrile rubber	1
6	167911	ROD, tie; 7" (177.8 mm) long, shoulder-to-shoulder	3
7	168210	NUT, shouldered	1
8	168211	COUPLING, connecting rod	1
9	168212	ROD, connecting; 3.69" (93.7 mm) long	1
11	210107	HYDRAULIC MOTOR See manual 307158 for parts	1
12	210208	DISPLACEMENT PUMP See manual 308043 for parts	1

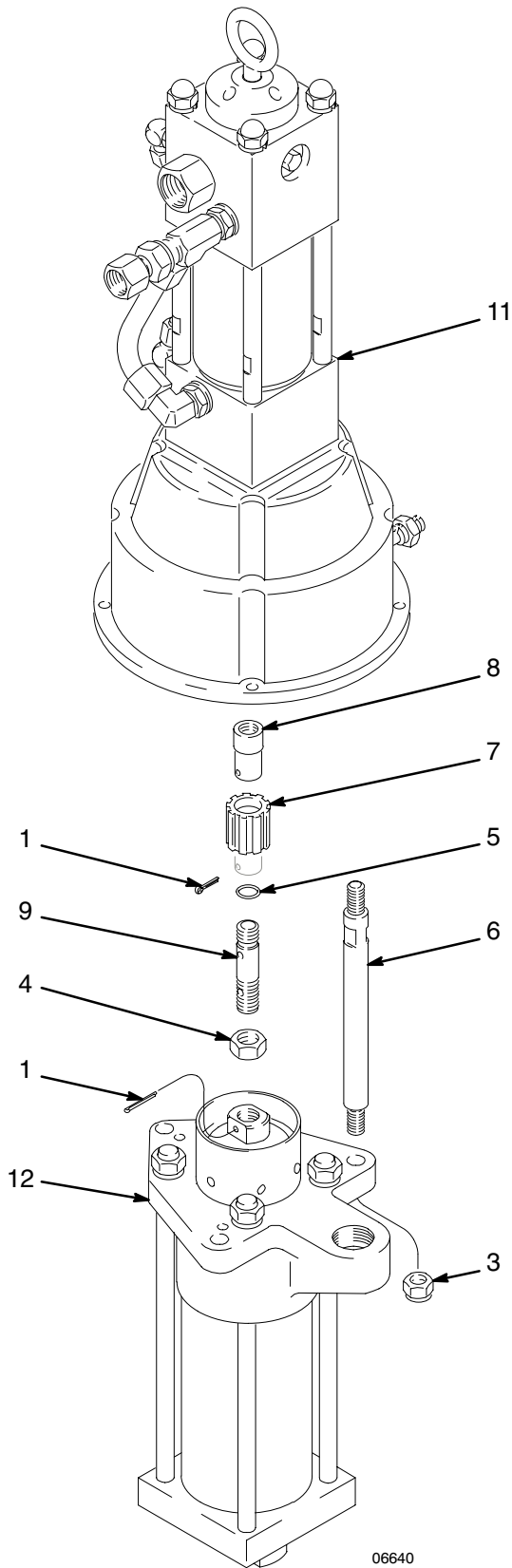

06640

# Dimensions

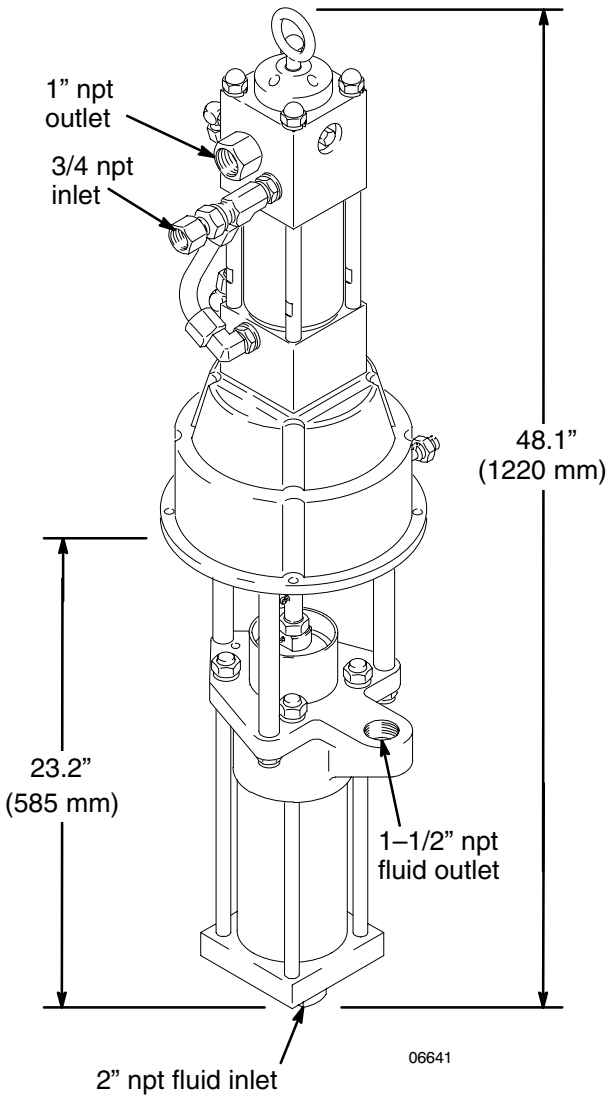

# Mounting Hole Layout

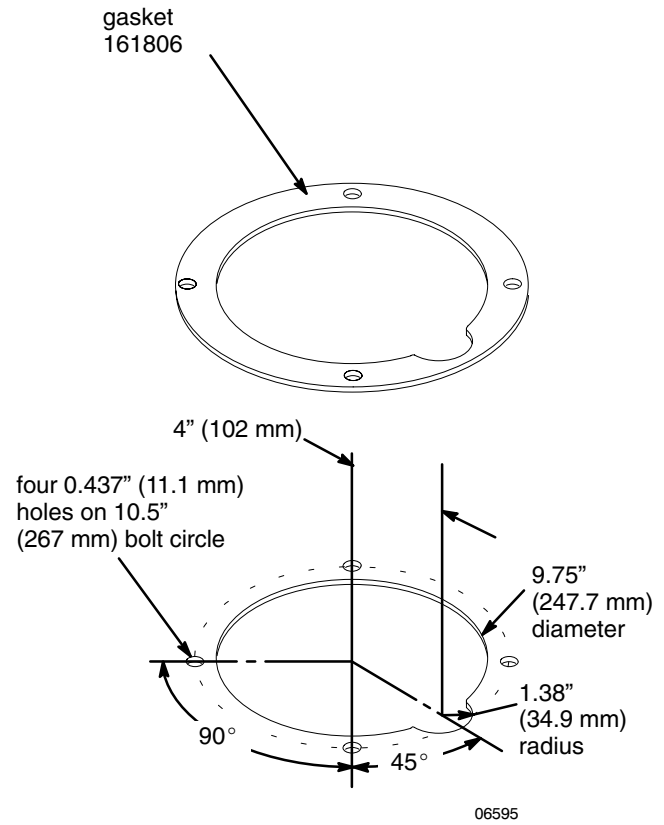

# Technical Data

Maximum hydraulic input pressure ..... 1500 psi (10.3 MPa, 103 bar)  
 Maximum pump outlet pressure ..... 1000 psi (7.0 MPa, 69 bar)  
 Hydraulic fluid consumption ..... 0.2 gal (0.76 liter) per cycle  
 Maximum Recommended Pump Speed ..... 50 cycles/min; 15 gpm (56.8 liter/min)  
 Wetted parts ..... *Displacement Pump: See manual 308043*

## Pump Performance Charts

**Pump Pressure Developed**

Hydraulic Input Pressure	Pump Outlet Pressure
100 psi (0.7 MPa, 7 bar)	66 psi (0.45 MPa, 4.5 bar)
200 psi (1.4 MPa, 14 bar)	132 psi (0.9 MPa, 9 bar)
300 psi (2.1 MPa, 21 bar)	199 psi (1.4 MPa, 14 bar)
400 psi (2.8 MPa, 28 bar)	265 psi (1.8 MPa, 18 bar)
500 psi (3.4 MPa, 34 bar)	331 psi (2.3 MPa, 23 bar)
600 psi (4.1 MPa, 41 bar)	397 psi (2.7 MPa, 27 bar)
700 psi (4.8 MPa, 48 bar)	463 psi (3.2 MPa, 32 bar)
800 psi (5.5 MPa, 55 bar)	530 psi (3.6 MPa, 36 bar)
900 psi (6.2 MPa, 62 bar)	596 psi (4.0 MPa, 40 bar)
1000 psi (6.9 MPa, 69 bar)	662 psi (4.5 MPa, 45 bar)
1100 psi (7.6 MPa, 76 bar)	728 psi (5.0 MPa, 50 bar)
1200 psi (8.3 MPa, 83 bar)	794 psi (5.4 MPa, 54 bar)
1300 psi (9.0 MPa, 90 bar)	861 psi (5.9 MPa, 59 bar)
1400 psi (9.7 MPa, 97 bar)	927 psi (6.4 MPa, 64 bar)
1500 psi (10.3 MPa, 103 bar)	993 psi (6.8 MPa, 68 bar)

**Pump Output**

Pump Speed (Cycles/min)	Hydraulic Fluid Required		Pump Output	
	gpm	liter/min	gpm	liter/min
5	1.0	3.8	1.5	5.6
10	2.0	7.6	3.0	11.4
15	3.0	11.4	4.5	17.0
20	4.0	15.1	6.0	22.7
25	5.0	18.9	7.5	28.4
30	6.0	22.7	9.0	34.1
35	7.0	26.5	10.5	39.7
40	8.0	30.3	12.0	45.4
45	9.0	34.1	13.5	51.0
50	10.0	37.8	15.0	56.8

# Graco Standard Warranty

Graco warrants all equipment manufactured by Graco and bearing its name to be free from defects in material and workmanship on the date of sale by an authorized Graco distributor to the original purchaser for use. With the exception of any special, extended, or limited warranty published by Graco, Graco will, for a period of twelve months from the date of sale, repair or replace any part of the equipment determined by Graco to be defective. This warranty applies only when the equipment is installed, operated and maintained in accordance with Graco's written recommendations.

This warranty does not cover, and Graco shall not be liable for general wear and tear, or any malfunction, damage or wear caused by faulty installation, misapplication, abrasion, corrosion, inadequate or improper maintenance, negligence, accident, tampering, or substitution of non-Graco component parts. Nor shall Graco be liable for malfunction, damage or wear caused by the incompatibility of Graco equipment with structures, accessories, equipment or materials not supplied by Graco, or the improper design, manufacture, installation, operation or maintenance of structures, accessories, equipment or materials not supplied by Graco.

This warranty is conditioned upon the prepaid return of the equipment claimed to be defective to an authorized Graco distributor for verification of the claimed defect. If the claimed defect is verified, Graco will repair or replace free of charge any defective parts. The equipment will be returned to the original purchaser transportation prepaid. If inspection of the equipment does not disclose any defect in material or workmanship, repairs will be made at a reasonable charge, which charges may include the costs of parts, labor, and transportation.

**THIS WARRANTY IS EXCLUSIVE, AND IS IN LIEU OF ANY OTHER WARRANTIES, EXPRESS OR IMPLIED, INCLUDING BUT NOT LIMITED TO WARRANTY OF MERCHANTABILITY OR WARRANTY OF FITNESS FOR A PARTICULAR PURPOSE.**

Graco's sole obligation and buyer's sole remedy for any breach of warranty shall be as set forth above. The buyer agrees that no other remedy (including, but not limited to, incidental or consequential damages for lost profits, lost sales, injury to person or property, or any other incidental or consequential loss) shall be available. Any action for breach of warranty must be brought within two (2) years of the date of sale.

Graco makes no warranty, and disclaims all implied warranties of merchantability and fitness for a particular purpose in connection with accessories, equipment, materials or components sold but not manufactured by Graco. These items sold, but not manufactured by Graco (such as electric motors, switches, hose, etc.), are subject to the warranty, if any, of their manufacturer. Graco will provide purchaser with reasonable assistance in making any claim for breach of these warranties.

In no event will Graco be liable for indirect, incidental, special or consequential damages resulting from Graco supplying equipment hereunder, or the furnishing, performance, or use of any products or other goods sold hereto, whether due to a breach of contract, breach of warranty, the negligence of Graco, or otherwise.

## **FOR GRACO CANADA CUSTOMERS**

The parties acknowledge that they have required that the present document, as well as all documents, notices and legal proceedings entered into, given or instituted pursuant hereto or relating directly or indirectly hereto, be drawn up in English. Les parties reconnaissent avoir convenu que la rédaction du présente document sera en Anglais, ainsi que tous documents, avis et procédures judiciaires exécutés, donnés ou intentés à la suite de ou en rapport, directement ou indirectement, avec les procédures concernées.

## Graco Information

**TO PLACE AN ORDER**, contact your Graco distributor, or call one of the following numbers to identify the distributor closest to you:

**1-800-367-4023 Toll Free**

**612-623-6921**

**612-378-3505 Fax**

*All written and visual data contained in this document reflects the latest product information available at the time of publication. Graco reserves the right to make changes at any time without notice.*

**Sales Offices:** Minneapolis, Detroit  
**International Offices:** Belgium, Korea, Hong Kong, Japan

**[www.graco.com](http://www.graco.com)**

PRINTED IN USA 307160 05/1975 Revised 05/2003