

OneWireless
XYR 6000 Pressure Transmitter
R120 User's Manual

34-XY-25-15
Revision 9
January 2012

Notices and Trademarks

**Copyright 2008-10 by Honeywell International Inc.
Revision 9 January 2012**

While this information is presented in good faith and believed to be accurate, Honeywell disclaims the implied warranties of merchantability and fitness for a particular purpose and makes no express warranties except as may be stated in its written agreement with and for its customers.

In no event is Honeywell liable to anyone for any indirect, special or consequential damages. The information and specifications in this document are subject to change without notice.

Honeywell, PlantScape, Experion PKS, and **TotalPlant** are registered trademarks of Honeywell International Inc.

Other brand or product names are trademarks of their respective owners.

Honeywell Process Solutions

1860 West Rose Garden Lane

Phoenix, Arizona 85027

About This Document

This document describes preparation, operation and maintenance of the XYR 6000 Wireless Pressure Transmitters. Mounting, installation and wiring are covered in other documents.

Honeywell does not recommend using devices for critical control where there is a single point of failure or where single points of failure result in unsafe conditions. OneWireless is targeted at open loop control, supervisory control, and controls that do not have environmental or safety consequences. As with any process control solution, the end-user must weigh the risks and benefits to determine if the products used are the right match for the application based on security, safety, and performance. Additionally, it is up to the end-user to ensure that the control strategy sheds to a safe operating condition if any crucial segment of the control solution fails.

Revision Information

Document Name	Document ID	Revision Number	Publication Date
XYR 6000 Pressure Transmitter R120 User's Manual	34-XY-25-15		
10KPSI and IS battery holder		8	November 2010
O'Ring part number (K7) update		9	January 2012

References

The following list identifies all documents that may be sources of reference for material discussed in this publication.

Document Title

XYR 6000 Transmitters Quick Start Guide
Getting Started with Honeywell OneWireless Solutions
OneWireless Wireless Builder User's Guide
OneWireless Builder Parameter Reference

Support and contact info

See back page for all country specific contact details

World Wide Web

Honeywell Solution Support Online:

<http://www.honeywell.com/ps/hfs>

Elsewhere

Call your nearest Honeywell office.











Training Classes

Honeywell Automation College:





<http://www.automationcollege.com>

Symbol Definitions

The following table lists those symbols used in this document to denote certain conditions.

Symbol	Definition
	ATTENTION: Identifies information that requires special consideration.
	TIP: Identifies advice or hints for the user, often in terms of performing a task.
CAUTION	Indicates a situation which, if not avoided, may result in equipment or work (data) on the system being damaged or lost, or may result in the inability to properly operate the process.
	CAUTION: Indicates a potentially hazardous situation which, if not avoided, may result in minor or moderate injury. It may also be used to alert against unsafe practices. CAUTION symbol on the equipment refers the user to the product manual for additional information. The symbol appears next to required information in the manual.
	WARNING: Indicates a potentially hazardous situation, which, if not avoided, could result in serious injury or death. WARNING symbol on the equipment refers the user to the product manual for additional information. The symbol appears next to required information in the manual.
	WARNING, Risk of electrical shock: Potential shock hazard where HAZARDOUS LIVE voltages greater than 30 Vrms, 42.4 Vpeak, or 60 VDC may be accessible.
	ESD HAZARD: Danger of an electro-static discharge to which equipment may be sensitive. Observe precautions for handling electrostatic sensitive devices.
	Protective Earth (PE) terminal: Provided for connection of the protective earth (green or green/yellow) supply system conductor.
	Functional earth terminal: Used for non-safety purposes such as noise immunity improvement. NOTE: This connection shall be bonded to Protective Earth at the source of supply in accordance with national local electrical code requirements.
	Earth Ground: Functional earth connection. NOTE: This connection shall be bonded to Protective Earth at the source of supply in accordance with national and local electrical code requirements.
	Chassis Ground: Identifies a connection to the chassis or frame of the equipment shall be bonded to Protective Earth at the source of supply in accordance with national and local electrical code requirements.

continued

Symbol	Description
	<p>The Factory Mutual[®] Approval mark means the equipment has been rigorously tested and certified to be reliable.</p>
	<p>The Canadian Standards mark means the equipment has been tested and meets applicable standards for safety and/or performance.</p>
	<p>The Ex mark means the equipment complies with the requirements of the European standards that are harmonized with the 94/9/EC Directive (ATEX Directive, named after the French "ATmosphere EXplosible").</p>
	<p>For radio equipment used in the European Union in accordance with the R&TTE Directive the CE Mark and the notified body (NB) identification number is used when the NB is involved in the conformity assessment procedure. The alert sign must be used when a restriction on use (output power limit by a country at certain frequencies) applies to the equipment and must follow the CE marking.</p>
	<p>The C-Tick mark is a certification trade mark registered to ACMA (Australian Communications and Media Authority) in Australia under the Trade Marks Act 1995 and to RSM in New Zealand under section 47 of the NZ Trade Marks Act. The mark is only to be used in accordance with conditions laid down by ACMA and RSM. This mark is equal to the CE Mark used in the European Union.</p> <p>N314 directly under the logo is Honeywell's unique supplier identification number.</p>

Contents

Support and contact info.....	iv
1. INTRODUCTION	1
1.1 Purpose	1
1.2 Scope.....	1
1.3 OneWireless network overview	1
1.4 About the transmitter.....	1
2. SPECIFICATIONS	3
2.1 European Union Usage.....	3
2.2 Certifications and approvals.....	4
Transmitter	4
Provisioning Device	5
2.3 Agency compliance information.....	5
FCC compliance statements	5
IC compliance statements	5
Radio Frequency (RF) statement	6
European Union restriction	6
Japanese Restrictions	6
2.4 Honeywell European (CE) Declaration of Conformity (DoC).....	7
For more information about the R&TTE Directive.....	9
2.5 IECEx Conditions of Certification.....	9
ATEX Conditions for Safe Use	9
3. PREPARATION	10
3.1 Installation	10
3.2 Configuration.....	10
3.3 Connecting to network	10
3.4 Calibrating the transmitter	10
Overview	10
Calibrate zero	10
4. FUNCTION BLOCKS.....	12
4.1 Introduction	12
4.2 Block description	12
Block types	12
Block diagram.....	12
4.3 Parameter details	13

- 5. OPERATION 14**
 - 5.1 Overview 14**
 - Display modes 14
 - Authentication Device 14
 - 5.2 Transmitter connection status..... 15**
 - 5.3 Transmitter PV display 16**
 - 5.4 Transmitter quick view of parameters 20**
 - 5.5 Transmitter menu 21**
 - Menu tree 21
 - 5.6 Authentication device menus 22**
 - Overview 22
 - Main menu 22
 - Security and Node Deployment 23
 - Device Local Configuration 25
 - Read Node Information 26
 - Advanced Options 28

- 6. MAINTENANCE/REPAIR 29**
 - 6.1 Introduction 29**
 - 6.2 Preventive maintenance 29**
 - 6.3 Inspecting and cleaning barrier diaphragms 29**
 - Tools required 29
 - Procedure 30
 - Torque ratings 31
 - 6.4 Replacing sensor module 32**
 - Tools required 32
 - Procedure 32
 - 6.5 Replacing batteries 34**
 - When to replace 34
 - Tools required 34
 - Procedure 34
 - 6.6 Replacing 24V external power module 36**
 - When to replace 36
 - Tools required 36
 - Procedure 36
 - 6.7 Replacing antenna 39**
 - Tools required 39
 - Procedure 39
 - 6.8 Parts 42**
 - Transmitter body 42
 - Meter body 43
 - 6.9 Dimension drawings 48**

Tables

Table 1 Calibrate zero	11
Table 2 Transmitter connection status	15
Table 3 PV engineering units	16
Table 4 PV status	17
Table 5 Device status	17
Table 6 Menu tree.....	21
Table 7 Buttons for Device Local Configuration	25
Table 8 Advanced Options	28
Table 9 Inspecting and Cleaning Barrier Diaphragms.....	30
Table 10 Process Head Bolt Torque Ratings	31
Table 11 Sensor module replacement.....	32
Table 12: IS Battery Pack replacement procedure.....	35
Table 13 24V External power module	38
Table 14 Antenna replacement procedure	40
Table 15 Parts (see Figure 13, Figure 14).....	44
Table 16 Parts	47
Table 17 Drawing numbers for DP models STDW924, STDW930, STDW974	48
Table 18 Drawing numbers for DHGP models STGW944, STGW974	48
Table 19 Drawing numbers for GP/AP models STGW94L, STGW97L, STGW98L, STAW94L, STGW99L.....	48

Figures

Figure 1 XYR 6000 Functional Diagram	2
Figure 2 Block Diagram	12
Figure 3 Main menu	22
Figure 4 Security and Node Deployment.....	23
Figure 5 Device Local Configuration screen.....	25
Figure 6 Read Node Information	26
Figure 7 Advanced Options	28
Figure 8 Assembly of DP Transmitter Process Heads	31
Figure 9 Sensor module removal and replacement	33
Figure 10: IS Battery Pack.....	35
Figure 11 24V Power Supply Module Assembly	37
Figure 12 Antenna replacement	41
Figure 13 STDW924, STDW930, STDW974.....	43
Figure 14 STGW944, STGW974	43
Figure 15 GP/AP models STGW94L, STGW97L, STGW98L, STGW99L, STAW94L.....	47

1. Introduction

1.1 Purpose

This manual describes the Honeywell OneWireless XYR 6000 Pressure Transmitter function, operation and maintenance.

1.2 Scope

The manual includes:

- Details of topics that relate uniquely to the Honeywell XYR 6000 Pressure Transmitter,
- This manual does not cover installation, mounting, or wiring. See XYR 6000 Transmitter Quick Start Guide (document 34-XY-25-21).

1.3 OneWireless network overview

OneWireless is an all digital, serial, two-way communication mesh network that interconnects industrial field sensors to a central system.

OneWireless has defined standards to which field devices and operator stations communicate with one another. The communications protocol is built as an "open system" to allow all field devices and equipment that are built to OneWireless standard to be integrated into a system, regardless of the device manufacturer. This interoperability of devices using OneWireless technology is to become an industry standard for automation systems.

1.4 About the transmitter

The XYR 6000 Pressure Transmitter is furnished with OneWireless interface to operate in a compatible distributed OneWireless system. The transmitter will interoperate with any OneWireless-registered device.

The transmitter includes OneWireless electronics for operating in a 2.4GHz network. It features function block architecture.

The XYR 6000 Pressure Transmitter comes in a variety of models for measurement applications involving one of these basic types of pressure:

- Differential pressure,
- Gauge pressure,
- Absolute pressure.

The transmitter measures the process pressure and transmits the measured value as a digital output signal in user-configured engineering units. Its major components are electronics housing and a meter body as shown in Figure 1 (a typical differential pressure model transmitter).

The XYR 6000 transmits its output in a digital OneWireless protocol format for direct digital communications with systems.

The Process Variable (PV) is available for monitoring and alarm purposes. Available PV update rates: 1, 5, 10, 30 seconds and are set on Wireless Builder. Slower update rates extend battery life. The meter body temperature is also available as a secondary variable for monitoring. Figure 1 shows a block diagram of the XYR 6000 Pressure transmitter's operating functions.

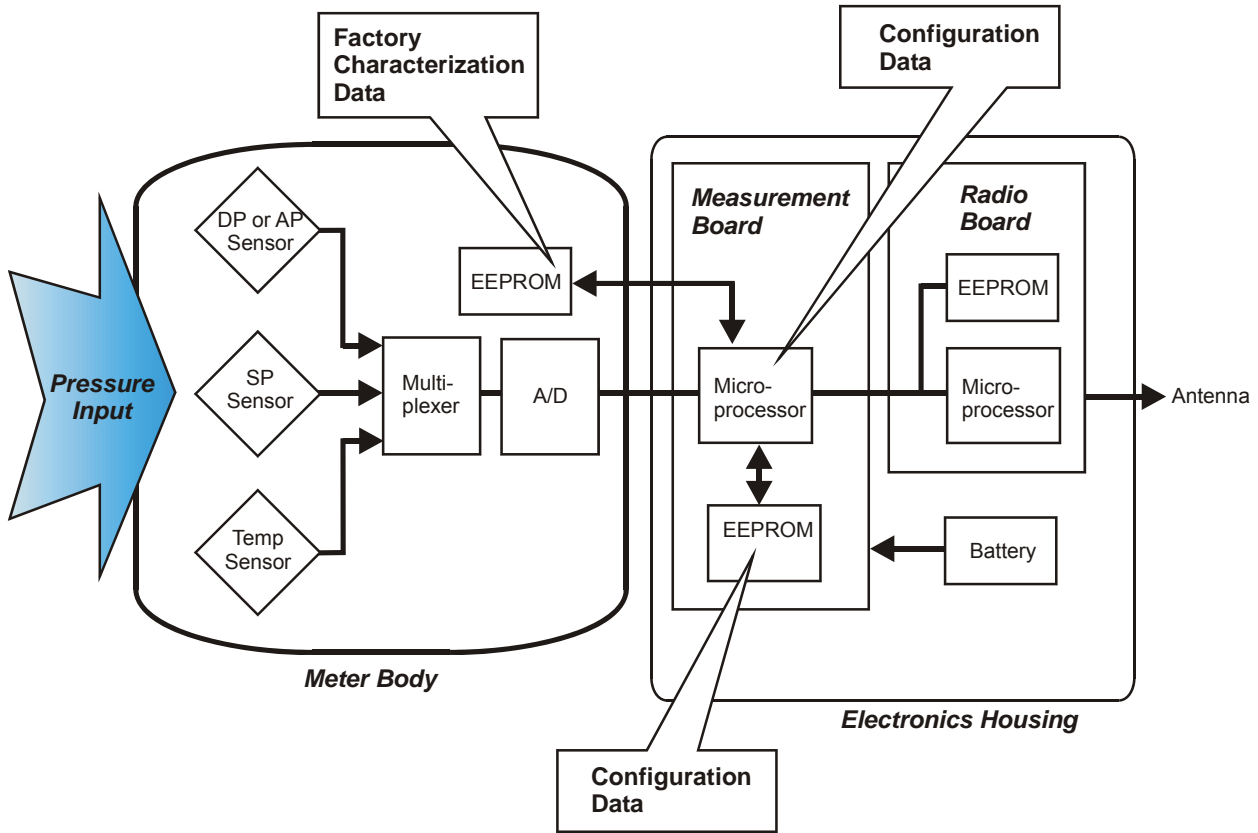

Figure 1 XYR 6000 Functional Diagram

2. Specifications

2.1 European Union Usage

This product may be used in any of the following European Union nations.

Country	ISO 3166 2 letter code	Country	ISO 3166 2 letter code
Austria	AT	Latvia	LV
Belgium	BE	Liechtenstein	LI
Bulgaria	BG	Lithuania	LT
Cyprus	CY	Malta	MT
Czech Republic	CZ	Netherlands	NL
Denmark	DK	Norway	NO
Estonia	EE	Poland	PL
Finland	FI	Portugal	PT
France	FR	Romania	RO
Germany	DE	Slovakia	SK
Greece	GR	Slovenia	SI
Hungary	HU	Spain	ES
Iceland	IS	Sweden	SE
Ireland	IE	Switzerland	CH
Italy	IT	United Kingdom	BG





2. Specifications

2.2. Certifications and approvals

2.2 Certifications and approvals

Transmitter

Refer to product label for applicable ratings.

Approval / Item	Ratings / Description
CSAcus Intrinsically Safe	CL I, Div 1, Groups A, B, C, & D; CL II, Div 1, Groups E, F & G; CL III, T4 CL I, Zone 0: Ex ia IIC, T4; CL I, Zone 0: AEx ia IIC, T4
CSAcus Explosionproof	CL I, Div 1, Groups A, B, C, & D; CL II, Div 1, Groups E, F & G; CL III, T4 CL I, Zone 1: Ex d IIC, T4; CL I, Zone 1: AEx d IIC, T4
CSAcus Nonincendive	CL I, Div 2, Groups A, B, C & D; CL II, Div 2, Groups F & G; CL III, Div 2, T4 CL I, Zone 2: Ex nA IIC, T4; CL I, Zone 2: AEx nA IIC, T4
FM Approvals Intrinsically Safe	CL I, Div 1, Groups A, B, C, & D; CL II, Div 1, Groups E, F & G; CL III, T4 CL I, Zone 0: AEx ia IIC, T4
FM Approvals Explosionproof	CL I, Div 1, Groups A, B, C, & D; CL II, Div 1, Groups E, F & G; CL III, T4 CL I, Zone 1: AEx d IIC, T4
FM Approvals Nonincendive	CL I, Div 2, Groups A, B, C & D; CL II, Div 2, Groups F & G; CL III, Div 2, T4 CL I, Zone 2: AEx nA IIC, T4
HON – ATEX Non-Sparking	 II 3 GD , Ex nA IIC, T4; Ta = 85°C, Zone 2
KEMA 08 ATEX0062X Intrinsically Safe Flameproof Non-Sparking	 II 1 GD Ex ia IIB; T4 Ta = 70°C; Ex tD A20 IP66 T90°C  II 2 GD Ex d [ia] IIB; T4 Ta = 70°C; Ex tD A21 IP66 T90°C  II 3 GD Ex nA [nL] IIC; T4 Ta = 84°C; Ex tD A22 IP66 T90°C
IECEX CSA 09.0001X Intrinsically Safe Flameproof Non-Sparking	Ex ia IIB; T4 Ta = 70°C; DIP A20 IP66 T90°C Ex d [ia] IIB; T4 Ta = 70°C; DIP A21 IP66 T90°C Ex nA [nL] IIC; T4 Ta = 84°C; DIP A22 IP66 T90°C
Process Connections in Division 2 / Zone 2	 Division 2 / Zone 2 apparatus may only be connected to processes classified as non-hazardous or Division 2 / Zone 2. Connection to hazardous (flammable or ignition capable) Division 1 / Zone 0, or 1 process is not permitted.
Enclosure Type	Type 4X, IP 66
CRN	Canadian Registration Number
Class II and III installations and Type 4X/IP66 applications require that all cable and unused entries be sealed with a NRTL (National Recognized Testing Laboratory) listed cable gland or conduit plug. Cable glands and conduit plugs are not supplied with the product.	

For detailed transmitter specifications see the following Specification and Model Selection Guides.

- XYR 6000 Wireless Transmitter Differential Pressure (document 34-XY-03-22)
- XYR 6000 Wireless Transmitter Absolute Pressure (document 34-XY-03-23)
- XYR 6000 Wireless Transmitter Gauge Pressure (document 34-XY-03-24)

Provisioning Device

Install the Provisioning Device application on any PDA having

- Windows Mobile version 4.2+
- Infrared port.

2.3 Agency compliance information

This section contains the Federal Communications Commission (FCC), Industry Canada (IC) and Radio Frequency compliance statements for the OneWireless XYR 6000 Wireless Transmitters device.



ATTENTION

XYR 6000 units must be professionally installed in accordance with the requirements specified in the *OneWireless XYR 6000 Agency Compliance Professional Installation Guide*.

FCC compliance statements

- This device complies with Part 15 of FCC Rules and Regulations. Operation is subject to the following two conditions: (1) This device may not cause harmful interference and (2) this device must accept any interference received, including interference that may cause undesired operation.
- This equipment has been tested and found to comply with the limits for a Class A digital device, pursuant to Part 15 of the FCC Rules. These limits are designed to provide reasonable protection against harmful interference in a residential installation. This equipment generates, uses, and can radiate radiofrequency energy and, if not installed and used in accordance with these instructions, may cause harmful interference to radio communications. Operation of this equipment in a residential area is likely to cause harmful interference in which case the user will be required to correct the interference at their own expense.
- Intentional or unintentional changes or modifications must not be made to the XYR 6000 Wireless Transmitters unless under the express consent of the party responsible for compliance. Any such modifications could void the user's authority to operate the equipment and will void the manufacturer's warranty.

IC compliance statements

- To reduce potential radio interference to other users, the antenna type and its gain should be so chosen that the equivalent isotropic radiated power (EIRP) is not more than that permitted for successful communication.
- Operation is subject to the following two conditions: (1) this device may not cause interference, and (2) this device must accept any interference, including interference that may cause undesired operation of the device.
- This Class A digital apparatus complies with Canadian ICES-003.
- French: Cet appareil numérique de la classe A est conforme à la norme NMB-003 du Canada.

2. Specifications

2.3. Agency compliance information

Radio Frequency (RF) statement

To comply with FCC's and Industry Canada's RF exposure requirements, the following antenna installation and device operating configurations must be satisfied.

- Remote Point-to-Multi-Point antenna(s) for this unit must be fixed and mounted on outdoor permanent structures with a separation distance between the antenna(s) of greater than 20cm and a separation distance of at least 20cm from all persons.
- Remote Fixed Point-to-Point antenna(s) for this unit must be fixed and mounted on outdoor permanent structures with a separation distance between the antenna(s) of greater than 20cm and a separation distance of at least 100cm from all persons.
- Furthermore, when using integral antenna(s) the XYR 6000 Wireless Transmitter unit must not be co-located with any other antenna or transmitter device and have a separation distance of at least 20cm from all persons.

European Union restriction

The XYR 6000 Wireless Transmitters are in conformity with the applicable portions of the ETSI standards as required by the R&TTE Directive 1999/5/EC.

France restricts outdoor use to 10mW (10dBm) EIRP in the frequency range of 2,454-2,483.5 MHz. Installations in France must limit EIRP to 10dBm, for operating modes utilizing frequencies in the range of 2,454 – 2,483.5MHz.

Japanese Restrictions

For locations in Japan the transmitter power is restricted to 12.14dBm/Mhz {(32mW (15.4 dBm)} maximum EIRP including the antenna.

2.4 Honeywell European (CE) Declaration of Conformity (DoC)

This section contains the European Declaration of Conformity (DoC) statement, for the XYR 6000 OneWireless products.

R&TTE Directive	1999/5/EC	LVD Directive	73/23/EEC	EMC Directive	2004/108/EC	ATEX Directive	94/9/EC
Harmonized Standards							
EN 300 328 V1.7.1	Emissions Specification and Method:						
EN 301 893 V1.4.1	Emissions Spec and Method						
EN 301 489-17 V1.2.1	Immunity Specification:						
EN 301 489-1 V1.6.1	Immunity Method:						
IEC61326-1 : 2006	Electrical equipment for measurement, control and laboratory use – EMC requirements – Part 1: General requirements						
EN 60079-0 : 2006	Electrical apparatus for explosive gas atmospheres - Part 0: General requirements						
EN 60079-1 : 2004	Electrical apparatus for explosive gas atmospheres - Part 1: Flameproof enclosure 'd'						
EN 60079-11 : 2007	Electrical apparatus for explosive gas atmospheres - Part 11: Intrinsic safety 'i'						
EC 60079-15 : 2005	Electrical apparatus for explosive gas atmospheres - Part 15: Type of protection 'n'						
EN 61241-0 : 2007	Electrical apparatus for use in the presence of combustible dust - Part 0: General Requirements						
EN 61241-1 : 2004	Electrical apparatus for use in the presence of combustible dust - Part 1-1: Electrical apparatus for use in the presence of combustible dust – Part 1: Protection by enclosures "tD"						
Manufacturer's Name and Address	Honeywell Process Solutions 525 East Market Street, York, PA 17403 USA						
Compliance Statement	The product herewith complies with the harmonized standards listed above. Typical product line systems and configurations have been tested, for compliance.						

2. Specifications

2.4. Honeywell European (CE) Declaration of Conformity (DoC)

European Declaration of Conformity statements

Language	Statement
Česky (Czech):	Honeywell tímto prohlašuje, že tento XYR 6000 Wireless Transmitters je ve shodě se základními požadavky a dalšími příslušnými ustanoveními směrnice 1999/5/ES.
Dansk (Danish):	Undertegnede Honeywell erklærer herved, at følgende udstyr XYR 6000 Wireless Transmitters overholder de væsentlige krav og øvrige relevante krav i direktiv 1999/5/EF.
Deutsch (German):	Hiermit erkläre Honeywell , dass sich das Gerät XYR 6000 Wireless Transmitters in Übereinstimmung mit den grundlegenden Anforderungen und den übrigen einschlägigen Bestimmungen der Richtlinie 1999/5/EG befindet.
Eesti (Estonian):	Käesolevaga kinnitab Honeywell seadme XYR 6000 Wireless Transmitters vastavust direktiivi 1999/5/EÜ põhinõuetele ja nimetatud direktiivist tulenevatele teistele asjakohastele sätetele.
English	Hereby, Honeywell , declares that this XYR 6000 Wireless Transmitters is in compliance with the essential requirements and other relevant provisions of Directive 1999/5/EC.
Español (Spanish):	Por medio de la presente Honeywell declara que el XYR 6000 Wireless Transmitters cumple con los requisitos esenciales y cualesquiera otras disposiciones aplicables o exigibles de la Directiva 1999/5/CE.
Ελληνική (Greek):	ΜΕ ΤΗΝ ΠΑΡΟΥΣΑ Honeywell ΔΗΛΩΝΕΙ ΟΤΙ XYR 6000 Wireless Transmitters ΣΥΜΜΟΡΦΩΝΕΤΑΙ ΠΡΟΣ ΤΙΣ ΟΥΣΙΩΔΕΙΣ ΑΠΑΙΤΗΣΕΙΣ ΚΑΙ ΤΙΣ ΛΟΙΠΕΣ ΣΧΕΤΙΚΕΣ ΔΙΑΤΑΞΕΙΣ ΤΗΣ ΟΔΗΓΙΑΣ 1999/5/ΕΚ.
Français (French):	Par la présente Honeywell déclare que l'appareil XYR 6000 Wireless Transmitters est conforme aux exigences essentielles et aux autres dispositions pertinentes de la directive 1999/5/CE.
Italiano (Italian):	Con la presente Honeywell dichiara che questo XYR 6000 Wireless Transmitters è conforme ai requisiti essenziali ed alle altre disposizioni pertinenti stabilite dalla direttiva 1999/5/CE.
Latviski (Latvian):	Ar šo Honeywell deklarē, ka XYR 6000 Wireless Transmitters atbilst Direktīvas 1999/5/EK būtiskajām prasībām un citiem ar to saistītajiem noteikumiem.
Lietuvių (Lithuanian):	Šiuo Honeywell deklaruoja, kad šis XYR 6000 Wireless Transmitters atitinka esminius reikalavimus ir kitas 1999/5/EB Direktyvos nuostatas.
Nederlands (Dutch):	Hierbij verklaart Honeywell dat het toestel XYR 6000 Wireless Transmitters in overeenstemming is met de essentiële eisen en de andere relevante bepalingen van richtlijn 1999/5/EG.
Malti (Maltese):	Hawnhekk, Honeywell , jiddikjara li dan XYR 6000 Wireless Transmitters jikkonforma mal-ftigijiet essenzjali u ma provvedimenti oħrajn rilevanti li hemm fid-Dirrettiva 1999/5/EC.
Magyar (Hungarian):	Alulírott, Honeywell nyilatkozom, hogy a XYR 6000 Wireless Transmitters megfelel a vonatkozó alapvető követelményeknek és az 1999/5/EC irányelv egyéb előírásainak.
Polski (Polish):	Niniejszym Honeywell oświadcza, że XYR 6000 Wireless Transmitters jest zgodny z zasadniczymi wymogami oraz pozostałymi stosownymi postanowieniami Dyrektywy 1999/5/EC.

Language	Statement
Português (Portuguese):	Honeywell declara que este XYR 6000 Wireless Transmitters está conforme com os requisitos essenciais e outras disposições da Directiva 1999/5/CE.
Slovensko (Slovenian):	Honeywell izjavlja, da je ta XYR 6000 Wireless Transmitters v skladu z bistvenimi zahtevami in ostalimi relevantnimi določili direktive 1999/5/ES.
Slovensky (Slovak):	Honeywell týmto vyhlasuje, že XYR 6000 Wireless Transmitters spĺňa základné požiadavky a všetky príslušné ustanovenia Smernice 1999/5/ES.
Suomi (Finnish):	Honeywell vakuuttaa täten että XYR 6000 Wireless Transmitters tyyppinen laite on direktiivin 1999/5/EY oleellisten vaatimusten ja sitä koskevien direktiivin muiden ehtojen mukainen.
Svenska (Swedish):	Härmed intygar Honeywell att denna XYR 6000 Wireless Transmitters står i överensstämmelse med de väsentliga egenskapskrav och övriga relevanta bestämmelser som framgår av direktiv 1999/5/EG.
Íslenska (Icelandic):	Hér með lýsir Honeywell yfir því að XYR 6000 Wireless Transmitters er í samræmi við grunnkröfur og aðrar kröfur, sem gerðar eru í tilskipun 1999/5/EC.
Norsk (Norwegian):	Honeywell erklærer herved at utstyret XYR 6000 Wireless Transmitters er i samsvar med de grunnleggende krav og øvrige relevante krav i direktiv 1999/5/EF.

For more information about the R&TTE Directive

The following website contains additional information about the Radio and Telecommunications Terminal Equipment (R&TTE) directive:

<http://ec.europa.eu/enterprise/rtte/faq.htm>

2.5 IECEx Conditions of Certification

Parts of the antenna are non-conducting and the area of the non-conducting part exceeds the maximum permissible areas for Category II 1 G (Zone 0) according to IEC 60079-0. Therefore when the antenna is used within a potentially explosive atmosphere, appropriate measures must be taken to prevent electrostatic discharge.

Impact and friction hazards need to be considered according to IEC 60079-0 when the transmitter that is exposed to the exterior atmosphere is made of light metal alloys, and used in Category II 1 G (Zone).

ATEX Conditions for Safe Use

Because the enclosure of the enclosure of the XYR 6000 Wireless Transmitter is made from aluminum, if it mounted in an area where the use of category 1G apparatus is required, it must be installed such that even in the event of rare incidents, ignition sources due to impact and friction sparks are excluded.

Special precautions shall be taken to prevent the surface of the antenna of the XYR 6000 Wireless Transmitter from being electrostatically charged

3. Preparation

3.1. Installation

3. Preparation

3.1 Installation

Refer to the XYR 6000 Transmitter Quick Start Guide (document 34-XY-25-21) for installation, mounting and wiring of your XYR 6000 transmitter.

3.2 Configuration

The XYR 6000 Transmitter contains the electronics interface compatible for connecting to the OneWireless network. An operator uses the Wireless Builder application to configure blocks, to change operating parameters, and to create linkages between blocks that make up the transmitter's configuration. These changes are written to the transmitter when it is authenticated by a security key.

3.3 Connecting to network

Use Authentication Device to connect your transmitter to the OneWireless network. See page 23.

3.4 Calibrating the transmitter

Overview

For all calibration methods, Wireless Builder must be used to unlock and take the channel out of service. You can set the zero offset at the transmitter by use of the infrared port. Additional calibration commands such as upper and lower trim are available in Wireless Builder.

Calibrate zero

Calibrates the sensor to correct the input measurement due to fill fluid and transmitter position effects once the transmitter is installed and operating under process conditions.



ATTENTION

Setting user trim points will effectively override the calibration zero. Normally the calibration zero is only required if you do not intend to provide process-specific trim points.

Table 1 Calibrate zero

Step	Action
1	<p>Apply zero input pressure for your transmitter's pressure type as follows.</p> <p>Differential: With process pressure applied, connect HP and LP inputs together using the crossover valve on the 3-valve manifold or other equivalent method.</p> <p>Gauge: Isolate the input pressure from the process and vent to the atmosphere.</p> <p>Absolute: Due to the difficulty of applying absolute 0 psi, zero calibration of the AP transmitter is not recommended.</p>
2	<p>In Wireless Builder, set the transmitter's Write Lock to Unlocked.</p>
3	<p>In Wireless Builder, set the transmitter's channel to OOS (Out of Service).</p>
4	<p>At the transmitter, verify the PV value is followed by an out of service (OUT SVC) message.</p> <p>Use Authentication Device's Device Local Configuration buttons to navigate to the transmitter's CAL menu.</p> <p>If the transmitter is locked a LOCKED message will be displayed. Go to step 2.</p> <p>If CAL menu is passcode protected, enter the passcode.</p> <p>If the channel is not out of service a WRONG MODE message will be displayed. Go to step 3.</p>
5	<p>Select CAL ZERO. With CAL ZERO displayed, press Enter to set the current applied pressure to zero. If successful the display will briefly show "ZERO SET". If unsuccessful the display will briefly show "ERROR".</p>
6	<p>Exit the menu.</p>
7	<p>Reverse step 1.</p>
8	<p>When ready, in Wireless Builder return the transmitter's channel to service and set Write Lock to Locked.</p>

4. Function blocks

4.1 Introduction

This section explains the construction and contents of the XYR 6000 Pressure Transmitter Function Blocks.

4.2 Block description

Block types

Blocks are the key elements that make up the transmitter’s configuration. The blocks contain data (block objects and parameters) which define the application, such as the inputs and outputs, signal processing and connections to other applications. The XYR 6000 Transmitter contains the following block types.

Block Type	Function
Device	Contains parameters related to the overall field device rather than a specific input or output channel within it. A field device has exactly one device block.
AITB	Contains parameters related to a specific process input or output channel in a measurement or actuation device. An AITB defines a measurement sensor channel for an analog process variable represented by a floating-point value. There is one AITB per sensor.
Radio	Contains parameters related to radio communication between the transmitter and the multimode(s).

Block diagram

Figure 2 shows the blocks of the XYR 6000 Transmitter.

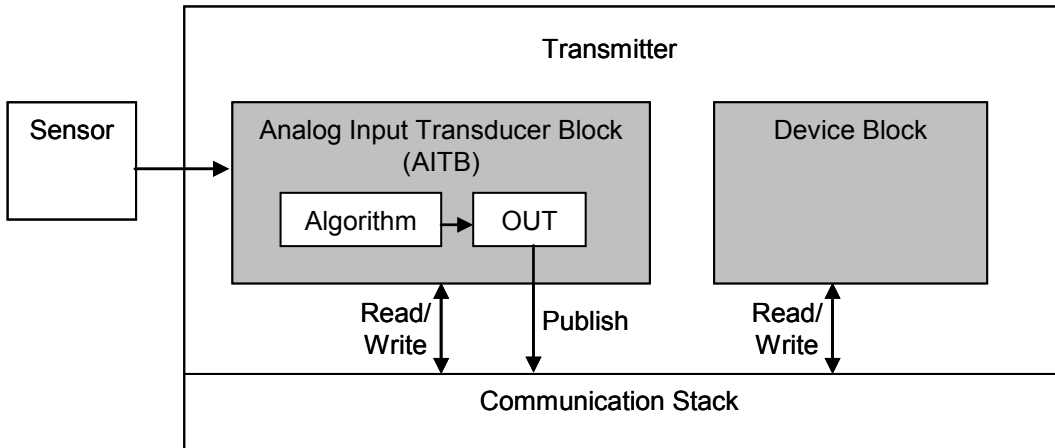

Figure 2 Block Diagram

Each of these blocks contains parameters that are standard WNSIA-transmitter defined parameters. The AITB and device blocks contain standard parameters common to all XYR 6000 transmitter models (that is, pressure, temperature, DI, corrosion, HLAI) as well as pressure-specific parameters. The radio block contains parameters for communication with the wireless network.

4.3 Parameter details

The transmitter itself displays a few basic parameters, such as tag, serial number, device revision, build, device address and WFN ID by accessing the quick view mode using the Authentication Device navigation keys.

For more information on parameters, refer to the following documents.

- OneWireless Wireless Builder User's Guide
- OneWireless Parameter Reference

5. Operation

5.1 Overview

Display modes

The transmitter has the following display modes.

- Test. Appears briefly after power-up to self-test the display.
- Connection status. Appears when transmitter is not fully connected to the OneWireless network. See section 5.2.
- PV display. Default mode of the transmitter displays the PV and any status messages. See section 5.3 on page 16.
- Quick view of transmitter identification parameters. Displays read-only parameters then returns to PV display. See section 5.4 on page 20.
- Menu. See section 5.5 on page 21.

Authentication Device

To navigate the transmitter displays and menus, hold the Authentication Device no more than 6" from the transmitter and aim the infrared beam at the transmitter display while tapping the Device Local Configuration buttons (Table 7).

Authentication Device menus are described in section 5.6 starting on page 22.

5.2 Transmitter connection status

Table 2 Transmitter connection status

Displayed status	Definition	What to do
NO KEY	Transmitter needs a key from the Authentication Device and is not transmitting.	Transmit a key to the transmitter. See page 23.
NOT CONN	Transmitter is in between discovery attempts.	<p>If Transmitter does not make a connection within five minutes, do the following:</p> <ul style="list-style-type: none"> • Check that Key is correct for the network you are trying to join. • Check that Multinode(s) in the local area are turned on and are already a secure part of the network. • Check if KeyServer is active. • Check the KeyServer Event Log to see if the Transmitter is actively trying to join. Errors in the Event Log show that the Transmitter is trying to join but that there are problems. Consult the OneWireless Wireless Builder documentation for troubleshooting errors.
DISCOVER	Transmitter has not made a connection to a Multinode and is in discovery (searching for a connection to a Multinode). Transmitter will automatically enter a power saving mode if it cannot make a connection and will retry later.	Wait for connection. If Transmitter does not make a connection within five minutes, see NOT CONN in this table.
SECURING	Transmitter has connected with the network and is validating its key.	Wait for connection. If Transmitter does not make a connection within five minutes, see NOT CONN in this table.
CONNECTD	<p>For units with radio firmware build* 53 or higher:</p> <p>Transmitter has validated the key and has made a secure connection with at least two Multinodes. Transmitter should appear in Wireless Builder as an uncommissioned device.</p> <p>For units with radio firmware build* 52:</p> <p>Transmitter has validated the key and has made a secure connection with at least one Multinode. Transmitter should appear in Wireless Builder as an uncommissioned device.</p>	<p>For units with radio firmware build* 53 or higher: No action required.</p> <p>For units with radio firmware build* 52: Transmitter will periodically look for a second Multinode in order to form a redundant connection to the network. If connected with only one Multinode Wireless Builder will display a Secondary Multinode Address of 0.</p>
NO REDUN	Appears only on units with radio firmware build* 53 or higher. No redundancy, that is, Transmitter has connected with only one Multinode.	No action required. The Transmitter will periodically look for a second Multinode in order to form a redundant connection to the network
*Use the PDA to determine your radio firmware build number (page 21).		

5.3 Transmitter PV display

In PV display, the following information is displayed in sequence.

Item displayed	Example	Details
PV value	+14.7	Latest PV value.
PV engineering units	PSI	See Table 3.
PV status	BAD	See Table 4. If PV status is not displayed then the PV value is good.
Device status	LOW BAT	See Table 5. If multiple device status messages are in effect, they are displayed one message per channel until all messages have been displayed. If no device status is displayed then the device status is normal.

Table 3 PV engineering units

Engineering units	Description
MPa	milliPascals
kPa	kilopascals
bar	Bars
mbar	Millibars
PSI	Pounds per square inch
G/CM2	Grams per square centimeter
KG/CM2	Kilograms per square centimeter
INH2O 4C	Inches of water at 4° C
INH2O 68F	Inches of water at 68° F
MMH2O 4C	Millimeters of water at 4° C
MMH2O 68F	Millimeters of water at 68° F
INHG 0C	Inches of mercury at 0° C
MMHG 0C	Millimeters of mercury at 0° C
PERCENT	Percent

Table 4 PV status

PV status	Cause - Action
(blank)	<ul style="list-style-type: none"> PV is normal – no action required
BAD	<ul style="list-style-type: none"> Possible calibration error – Clear calibration AITB can not execute due to internal firmware state – Attempt cold restart of device. AITB can not execute due to hardware fault – Replace sensor board Sensor failure – Check Connection between Sensor board and Meter Body. Meter Body Characterization Data is Bad – Replace Meter Body Meter Body A/D Failure – Replace Meter Body Meter Body Sensor Fail – Replace Meter Body
BAD CONFIG	<ul style="list-style-type: none"> Configuration is bad – Check possible units and range settings for input type and correct AITB configuration.
BAD E FAIL	<ul style="list-style-type: none"> Hardware fault detected - Replace sensor board
UNC	<ul style="list-style-type: none"> Warning: Calibration (zero or trim) is causing excessive adjustment to characterization value. Warning: Input inaccurate due to uncertain input data integrity. Warning: Input inaccurate due to input conversion limitations or resolution. Warning: Input outside of characterized range. Value is estimated.

Table 5 Device status

Transmitter display	Wireless Builder display	Definition	What to do
OUT SVC	OOS	All channels are out of service.	Restore mode to Auto in Wireless Builder.
SENS ERR	Sensor Error	Sensor can not access meter body A/D converter.	Check connection between sensor module and meter body. If still doesn't work, replace sensor. See page 32.
CHAR ERR	Characterization Error	Sensor can not access meter body characterization or the characterization is invalid.	Check connection between sensor module and meter body. If still doesn't work, replace sensor. See page 32.
OVR TEMP	Over Temperature	The meter body has exceeded the maximum temperature as defined by the meter body characterization data.	Determine cause excessive temperature.

5. Operation

5.3. Transmitter PV display

Transmitter display	Wireless Builder display	Definition	What to do
OVR LOAD	Over Load	The applied pressure has exceeded the limit defined by the meter body characterization data.	Determine cause of over pressure.
CAL ERR	Calibration Error	Calibration Data Invalid or could not be read.	Use Cal Clear, Restore, or User Calibrate.
LOW BAT	Low Battery	Battery Voltage Critically Low	Replace batteries as soon as possible. See page 34.
LOW PWR	Low Power	External Power Critically Low	Check external 24V power supply
NO RADIO	Radio Interprocessor Comm Error	Radio Board is not accessible.	Restart both the radio and sensor. If condition persists, replace sensor module. See page 32.
BAD RADIO SPI	Sensor Radio SPI Communication Failure	Radio detected loss of communication with sensor board over the inter-processor communication link.	Restart both the radio and sensor. If condition persists, replace sensor module. See page 32.
BAD RADIO EEPROM	EEPROM SPI Communication Failure	Radio EEPROM SPI Communication failure	The radio will not be able to perform firmware upgrades but will operate normally using installed code. Replace sensor module. See page 32.
RADIO WDT RESET	WDT Reset Occurred	Radio Watch Dog Timeout detected	Restart both the radio and sensor. If condition persists, replace sensor module. See page 32.
BAD RADIO	Radio Circuitry Failure	Radio circuitry has failed	The radio processor detected error on internal radio circuitry. Replace sensor module. See page 32.
The following status messages have multiple meanings. Refer to Wireless Builder Device Status for exact cause.			
INP FAIL	Input Failure	Input Error	Possible meter body sensor failure.
INP FAIL	A/D Failure	Diagnostics detected defect with Analog to Digital Converter.	Replace sensor module. See page 32.
E FAIL	A/D Failure	Diagnostics detected defect with Analog to Digital Converter.	Replace sensor module. See page 32.
E FAIL	Electronics Failure	Electronic Failure detected on Sensor Board. Could be caused by one of the status items marked by *.	Restart both the radio and sensor. If condition persists, replace sensor module. See page 32.

Transmitter display	Wireless Builder display	Definition	What to do
E FAIL*	NVM Fault*	Startup diagnostics detected defect in Sensor Non-Volatile Memory	Replace sensor module. See page 32.
E FAIL*	Program Memory Fault*	Startup diagnostics detected defect in Sensor Read Only Memory	Replace sensor module. See page 32.
E FAIL*	RAM Fault*	Startup diagnostics detected defect in Processor Random Access Memory	Replace sensor module. See page 32.
The following statuses are displayed only in Wireless Builder Device Status.			
blank	Excess Zero Calibration	The selected zero offset or the lower calibration trim point is beyond 5% of the lower end of the characterized range of the device.	Clear Calibration
blank	Excess Span Calibration	The calibrated upper and lower trim has produced a span that is greater than 5% of the characterized span of the transmitter.	Clear Calibration Or Set Factory Calibration Or Check the applied trim points and re-attempt lower and upper (trim) calibration.
blank	Excess Calibrated Range	The selected calibration points used for upper and lower trim are outside the characterized range of the transmitter.	Check that the upper and lower trim points are both within the characterized range of the transmitter and re-attempt upper and lower (trim) calibration.
blank	Calibration Cleared	Indicates that both the upper and lower trim points as well as the zero offset has been cleared. The calibration source is none.	Select Factory Calibration Or Calibration the zero offset Or Calibrate using the lower and upper trim points.
blank*	Device/Firmware Mismatch*	Sensor Board Firmware Error. The software did not pass verification tests.	Replace sensor module. See page 32.

5. Operation

5.4. Transmitter quick view of parameters

Transmitter display	Wireless Builder display	Definition	What to do
blank*	Heap Memory Not Available*	Heap Allocation Failure. Software detected heap shortage and some communication packets may have been dropped.	Clear by warm restart of device. If condition persists contact Honeywell service.
blank*	Watchdog Timer Error*	Sensor Watchdog Timeout. The processor was restarted due to unexpected operation.	Clear by warm restart of device. If condition persists contact Honeywell service.

5.4 Transmitter quick view of parameters

If the Up or Down key is pressed using the Authentication Device while in PV display mode, the display will enter parameter quick view mode. Successive presses of the Up key will increment to the next parameter in the following table, or exit to PV mode if at the last parameter. The Down key will decrement to the previous parameter or exit if at the first parameter. The Enter key will exit to PV display mode at any time.

Position	Parameter	Description
1	Vendor Name	HONEYWELL
2	HONEYWELL	XYR 6000 MULTI AI DI DO
3	Tag Name	HON_XYR6000_MAIDIDO_1234567890
4	SDREV	Sensor device revision
5	SBLD	Sensor build number
6	Radio Type	DSSS
7	RBLD	Radio build number
8	WFN	Wireless field network identifier
9	NET	Network device address
10	MODE/CHANNEL	Frequency hopping mode & channel

5.5 Transmitter menu

Menu tree

At the PV display, press Enter to access the menus. To interact with the menus use the Device Local Configuration onscreen buttons (page 25) or the buttons on your PDA.

Table 6 Menu tree

Menu item	Description																																	
CAL	Calibration menu. May be password-protected. See Table 7 on page 25 for password number entry.																																	
CAL ZERO	Calibrate zero. See page 10.																																	
RADIO	Radio menu																																	
PRI RSSI	<p>Primary receive signal strength. Read only. Signal strength 00 is too weak to connect to the network.</p> <table border="1"> <thead> <tr> <th><u>Displayed Value</u></th> <th><u>Value dBm</u></th> <th><u>Rx Margin dB</u></th> </tr> </thead> <tbody> <tr> <td>00</td> <td>< -86</td> <td>< 10</td> </tr> <tr> <td>01</td> <td>-86 to -81</td> <td>10 to 15</td> </tr> <tr> <td>02</td> <td>-80 to -75</td> <td>16 to 21</td> </tr> <tr> <td>03</td> <td>-74 to -69</td> <td>22 to 27</td> </tr> <tr> <td>04</td> <td>-68 to -63</td> <td>28 to 33</td> </tr> <tr> <td>05</td> <td>-62 to -57</td> <td>34 to 39</td> </tr> <tr> <td>06</td> <td>-56 to -51</td> <td>40 to 45</td> </tr> <tr> <td>07</td> <td>-50 to -45</td> <td>46 to 51</td> </tr> <tr> <td>08</td> <td>-44 to -11</td> <td>52 to 85</td> </tr> <tr> <td>09</td> <td>≥ -10</td> <td>Saturation</td> </tr> </tbody> </table>	<u>Displayed Value</u>	<u>Value dBm</u>	<u>Rx Margin dB</u>	00	< -86	< 10	01	-86 to -81	10 to 15	02	-80 to -75	16 to 21	03	-74 to -69	22 to 27	04	-68 to -63	28 to 33	05	-62 to -57	34 to 39	06	-56 to -51	40 to 45	07	-50 to -45	46 to 51	08	-44 to -11	52 to 85	09	≥ -10	Saturation
<u>Displayed Value</u>	<u>Value dBm</u>	<u>Rx Margin dB</u>																																
00	< -86	< 10																																
01	-86 to -81	10 to 15																																
02	-80 to -75	16 to 21																																
03	-74 to -69	22 to 27																																
04	-68 to -63	28 to 33																																
05	-62 to -57	34 to 39																																
06	-56 to -51	40 to 45																																
07	-50 to -45	46 to 51																																
08	-44 to -11	52 to 85																																
09	≥ -10	Saturation																																
SEC RSSI	Secondary receive signal strength. Same as PRI RSSI. Read only.																																	
WFN ID	Wireless Field Network ID. Read only.																																	
DEV ADD	Device address. Read only.																																	
TX POWER	Radio transmit power. Read only.																																	

5.6 Authentication device menus

Overview

Hold the Authentication Device no more than 6" from the transmitter and aim the infrared beam at the transmitter display while tapping on the screen command or button.

Main menu

The main menu is shown below. Details start on the next page.

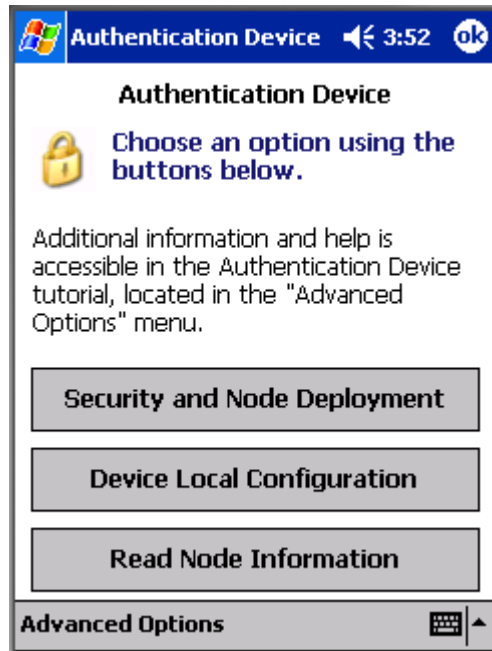

Figure 3 Main menu

Security and Node Deployment

Use this to:

- receive new security keys,
- transmit security keys for connecting the transmitter (or other nodes) to the OneWireless network,
- clear all security keys from the PDA,
- clear the transmitter's key and reset its configuration to factory default (such as for decommissioning).

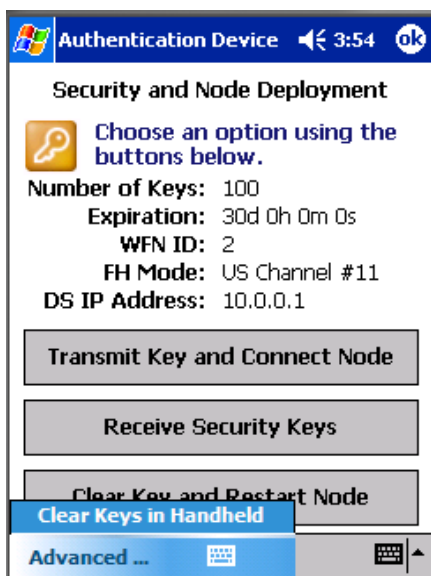

Figure 4 Security and Node Deployment

5. Operation

5.6. Authentication device menus

To connect your transmitter to the OneWireless network perform the following steps.

Step	Action
1	<p>If the PDA contains no keys, obtain new security keys from the PC application Key Server Manager.</p> <p>To do this, select Receive Security Keys. Keys can be received either through Infrared (by aiming PDA at the infrared dongle) or through an ActiveSync/USB connection. See Key Server Communication Method under Advanced options on page 28 for details.</p> <p>Important: The Comm Method settings must match in the PC's Key Server Manager and in the Authentication Device (both must be set to Infrared or both to ActiveSync) in order for your PDA to receive security keys. See Key Server Communication Method under Advanced options on page 28 for details.</p>
2	<p>When the Authentication Device has valid unexpired keys, aim it at the transmitter and transmit a key to the transmitter. The transmitter will validate the key and then use it to make a connection to the OneWireless Network. The Transmitter may continue to show the diagnostic message "NO KEY" for a brief time while it validates the key before showing the "DISCOVER" message.</p> <p>To verify your transmitter has been authenticated, see the Connection prompt on the Read Node Info screen (page 26).</p>

To decommission your transmitter from the OneWireless network, select **Clear Key and Restart Node**. This clears the transmitter's key, network and security configurations, and resets the transmitter to its factory default settings. perform the following steps.

Select **Clear Keys from Handheld** (under Advanced Options) when:

- The PDA has keys from one system, but you have moved your Authentication Device to another system, or
- you want to clear all keys so that you cannot deploy any more keys without going to the key server manager and getting more.

For more details on keys, refer to Getting Started with Honeywell OneWireless Solutions.

Device Local Configuration

Use Device Local Configuration buttons (Table 7) to navigate the transmitter menus (Table 6) and to make selections and changes. You can also use the PDA buttons.

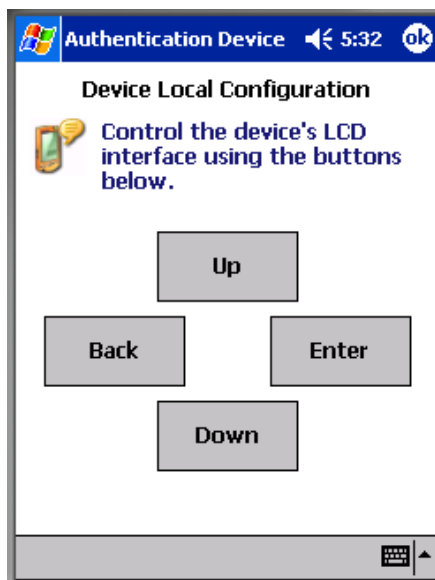

Figure 5 Device Local Configuration screen

Table 7 Buttons for Device Local Configuration

Button	Function
Enter	<ul style="list-style-type: none"> • Enter the Menu Tree. • Enter submenu of the menu that is appearing on the screen. • Execute action. • Submit the entered number while doing number entry. • Read value of certain displayed parameters.
Up	<ul style="list-style-type: none"> • Go to the next menu in the same level. • View quick view parameters in Normal Display Sequence (PV Display). • During number entry, increment the digit or change +/- sign.
Down	<ul style="list-style-type: none"> • Go to the previous menu in the same level. • View quick view parameters in Normal Display Sequence (PV Display). • During number entry, decrement the digit or change +/- sign.
Back	<ul style="list-style-type: none"> • Go to the upper menu level. • When changing a number value, move cursor to the left/more significant digit, then wrap around to the least significant digit.

5. Operation

5.6. Authentication device menus

Read Node Information

Use this to read the transmitter information shown in Figure 6. Similar to quick view parameters on the transmitter display. (See page 20.)

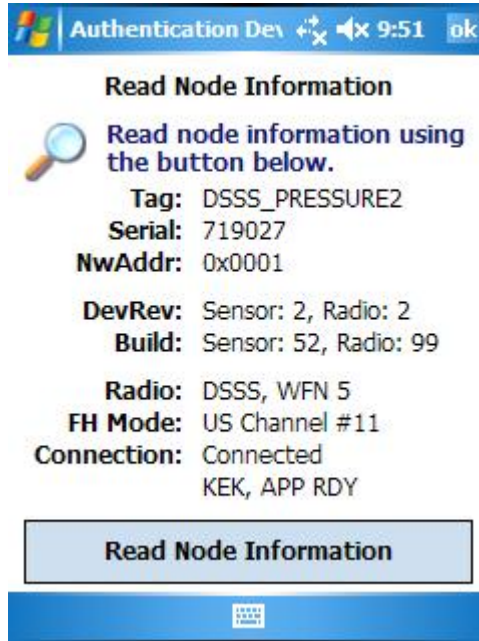

Figure 6 Read Node Information

Item	Description
Tag	The name given to this transmitter
Serial	Transmitter serial number. This is the WBSN on the transmitter's nameplate. Do not confuse this with the other nameplate item marked "Serial."
NwAddr	Network Address of the device in hexadecimal.
DevRev	Device Revision. This parameter changes whenever objects and parameters are added, deleted, or their data type or range changes. It does not change if the application firmware changes without affecting the device description. Range: 0 to 65535.
Build	Sensor firmware and radio firmware build numbers.
Radio	Hardware radio type, FHSS or DSSS WFN ID: Wireless Field Network ID. Range: 0 to 255.

Item	Description
FH Mode	<p>Frequency group or frequency channel selection used by the wireless network of the device. The value must match the value set in the gateway and interface nodes to allow communication between the device and the wireless network.</p> <p>Modes:</p> <ul style="list-style-type: none"> US Channel #1 US Channel #6 US Channel #11 US Guard Bands EU Channel #1 EU Channel #7 EU Channel #13 EU Guard Bands US/EU Spec Div A US/EU Spec Div B US/EU Channel #3 US/EU Channel #10 Complete Spectrum
Connection	<p>The first line displays one of the following connection states.</p> <p>No Security Key – No security key has been deployed to the device or multinode. The user must give a security key to the device or multinode before it will join the wireless sensor network.</p> <p>No Connection – A security key exists in the device or multinode, but no connection has been formed. The device or multinode is waiting to form a connection and will automatically retry shortly. Users may transmit a new security key in order to force the device or multinode to immediately retry to form a connection.</p> <p>Discovering – The device is attempting to form a connection to the wireless sensor network. The device is discovering multinodes and, if a multinode is found, will transition to the securing state.</p> <p>Securing – The device is attempting to form a connection to the wireless sensor network. The device has discovered one or two multinodes and is attempting to form a secure session. If successful, the device will transition to the connected state.</p> <p>Connected – A secure connection is formed with one or two multinodes.</p> <p>The second line contains detailed state information useful for problem reporting.</p>

5. Operation

5.6. Authentication device menus

Advanced Options

Advanced options are non-typical configuration commands.

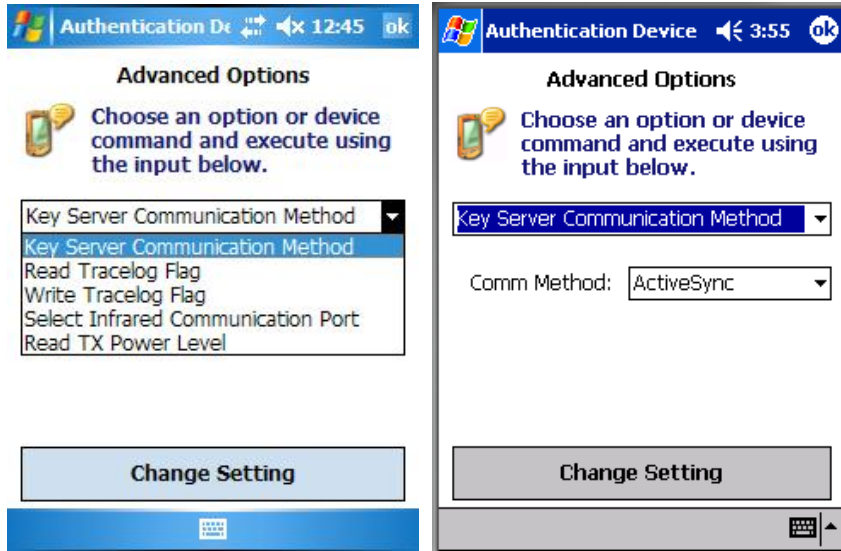

Figure 7 Advanced Options

Table 8 Advanced Options

Item	Description
Key Server Communication Method	<p>Determines how the PDA will receive security keys from the PC's Key Server Manager application. From the Comm Method menu select one of the following methods.</p> <p>ActiveSync – Select this to receive keys over a USB connection, such as while the PDA battery is being charged in its base.</p> <p>Infrared – Select this to receive keys over the infrared port.</p> <p>Important: The Comm Method settings match in the PC's Key Server Manager and in the Authentication Device (both must be set to Infrared or both to ActiveSync) in order for your PDA to receive security keys.</p>
Read Tracelog Flag	Not available for transmitters. Used with multinodes. Reads conditional tracelog flag value. Tracelog flags are used to enable and disable logging functionality used for field support.
Write Tracelog Flag	Not available for transmitters. Used with multinodes. Writes conditional tracelog flag value. Tracelog flags are used to enable and disable logging functionality used for field support .
Select Infrared Communication Port	Overrides the detected infrared communication port detected on your PDA. If infrared communication is not functioning, you can override the detected settings using this option.
Read TX Power Level	Reads the transmission power level of the transmitter radio.

6. Maintenance/Repair

6.1 Introduction

This section provides information about preventive maintenance routines and replacing damaged parts. The topics covered in this section are:

Preventive maintenance of the meter body barrier diaphragms and process piping to the transmitter.

Replacement of damaged parts such as the transmitter display/sensor and batteries.

6.2 Preventive maintenance

The XYR 6000 transmitter itself does not require any specific maintenance routine at regularly scheduled intervals. However, you should consider carrying out these typical inspection and maintenance routines on a schedule that is dictated by the characteristics of the process medium being measured and whether blow-down facilities or purge systems are being used.

Check piping for leaks.

Clear the piping of sediment or other foreign matter.

Clean the transmitter's pressure chambers including the barrier diaphragms.

6.3 Inspecting and cleaning barrier diaphragms

Depending on the characteristics of the process medium being measured, sediment or other foreign particles may collect in the process head cavity/chamber and cause faulty measurement. In addition, the barrier diaphragm or diaphragms in the transmitter's meter body may become coated with a residue from the process medium. The latter is also true for external diaphragms on flange mount and remote seal type transmitters.

In most cases, you can readily remove the process head or heads from the transmitter's meter body to clean the process head cavity and inspect the barrier diaphragm or diaphragms. For flange mount and remote seal diaphragms, you may only need to run a purge line in the tank to rinse off the face of the diaphragm.

The procedure in Table 9 outlines the general steps for inspecting and cleaning barrier diaphragms. You may have to modify the steps to meet your particular process or transmitter model requirements. Figure 8 shows an exploded view of a DP transmitter's meter body for reference.



WARNING

Risk of death or serious injury by explosion. Do not open transmitter enclosure when an explosive gas atmosphere is present.

Tools required



- 5/8" Wrench or Socket for 7/16" Dia. Hex Bolt
- 3/4" Wrench or Socket for 7/16" Hex Nut
- Calibrated torque wrench. For the most accurate performance, select a torque wrench with which the applied torque value is near the middle of the tool's torque range. For example, if applying 68 N-M (50 Lb-Ft), select a torque wrench with range of 7 N-M to 136 N-M (5 to 100 Lb-Ft).

6. Maintenance/Repair

6.3. Inspecting and cleaning barrier diaphragms

Procedure

Table 9 Inspecting and Cleaning Barrier Diaphragms

Step	Action
1	Close all valves and isolate transmitter from process. Open vent in process head to drain fluid from transmitter's meter body, if required.
	ATTENTION We recommend that you remove the transmitter from service and move it to a clean area before taking it apart.
	WARNING Risk of death or serious injury by explosion. Do not open transmitter enclosure when an explosive gas atmosphere is present.
2	Remove nuts from bolts that hold process head or heads to meter body. Remove process heads and bolts. See Figure 8.
3	Remove gasket and clean interior of process head using soft bristle brush and suitable solvent.
	CAUTION Diaphragm surface is fragile. Be very gentle, do not damage.
4	Inspect barrier diaphragm for any signs of deterioration or corrosion. Look for possible residue and clean if necessary. If diaphragm is dented, has distorted convolutions or radial wrinkles, performance may be affected. Contact Honeywell for assistance.
5	Replace process head gasket.
	ATTENTION <ul style="list-style-type: none">We recommend that you install a new gasket whenever a process head is removed for cleaning.
	For process heads of a GP or AP transmitter with dual-head design, see illustration for differential pressure transmitters in Figure 8.
6	Coat threads on process head bolts with anti-seize compound such as "Neverseize" or equivalent.
7	Replace process head or heads and bolts. Finger tighten nuts.
8	Use a torque wrench to gradually tighten nuts to torque rating shown in Table 10, in sequence shown in Figure 8. Tighten head bolts in stages of 1/3 full torque, 2/3 full torque, and then full torque.
9	Return transmitter to service.

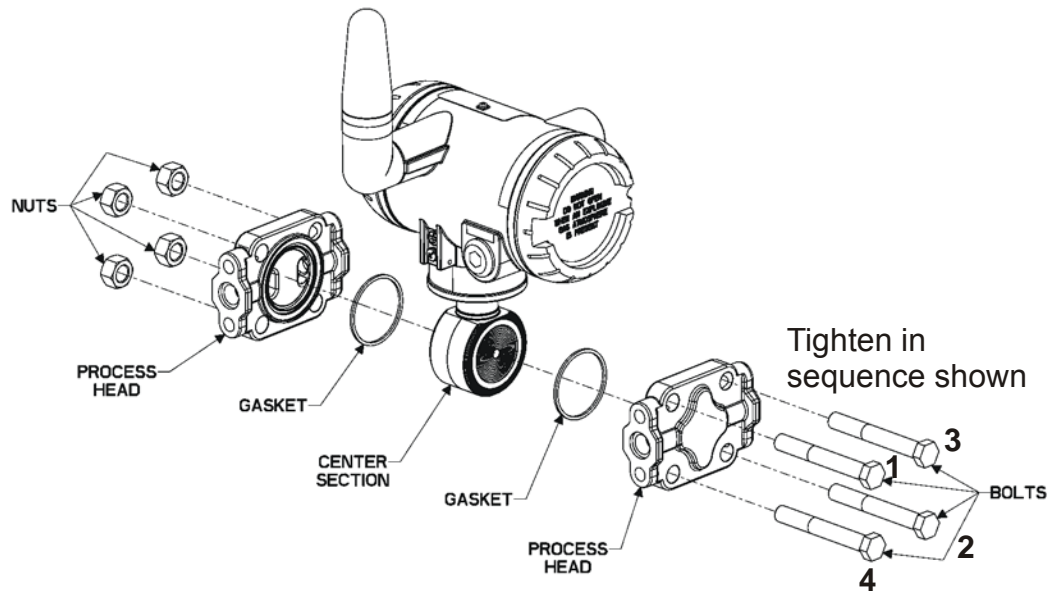

Figure 8 Assembly of DP Transmitter Process Heads

Torque ratings

Table 10 lists process head bolt torque ratings for given transmitter type.

Table 10 Process Head Bolt Torque Ratings

Meterbody Type	Bolt Type 7/16 x 14 UNC		
	51452557-001 (Carbon Steel - standard; no option specified)	51452557-002 and -003 (NACE ["CR" option], Non- NACE ["SS" option] 316 Stainless Steel)	51452557-004 (B7M Alloy Steel ["B7" option])
50019775XXXX	67,8 N•M +/- 3,4 N•M (50.0 Lb-Ft +/- 2.5 Lb-Ft)	56,9 N•M +/- 2,8 N•M (42.0 Lb-Ft +/- 2.1 Lb-Ft)	48,8 N•M +/- 2,4 N•M (36.0 Lb-Ft +/- 1.8 Lb-Ft)

6.4 Replacing sensor module

Tools required

- #1 Phillips Screwdriver or 1/8" Slotted Screwdriver
- Torque Screwdriver
- 1.5 mm hex key

Procedure



WARNING

Risk of death or serious injury by explosion. Do not open transmitter enclosure when an explosive gas atmosphere is present.



CAUTION

Take precautions against electrostatic discharge to prevent damaging the sensor module.

Table 11 Sensor module replacement

Step	Action
1	Honeywell recommends that the transmitter be removed from service and moved to a clean area before servicing.
2	Loosen the M3 locking set screw on the display end-cap. See item 1 in Figure 9. Unscrew and remove the end cap.
3	Loosen the two screws on the sensor module. See items 2 in Figure 9.
4	Disconnect each connector on the sensor module. See items 3 in Figure 9.
5	Install new sensor module. Be sure to orient sensor module in the proper viewing orientation before tightening two sensor compartment screws.
	Reverse steps 1-4.
	Torque screws to 0,4 – 0,6 N-M (3.5 – 5.3 Lb-in).
	Honeywell recommends lubricating the end cap O-ring with a Silicone Grease such as Dow Corning #55 or equivalent before replacing the end cap.
	Return transmitter to service.

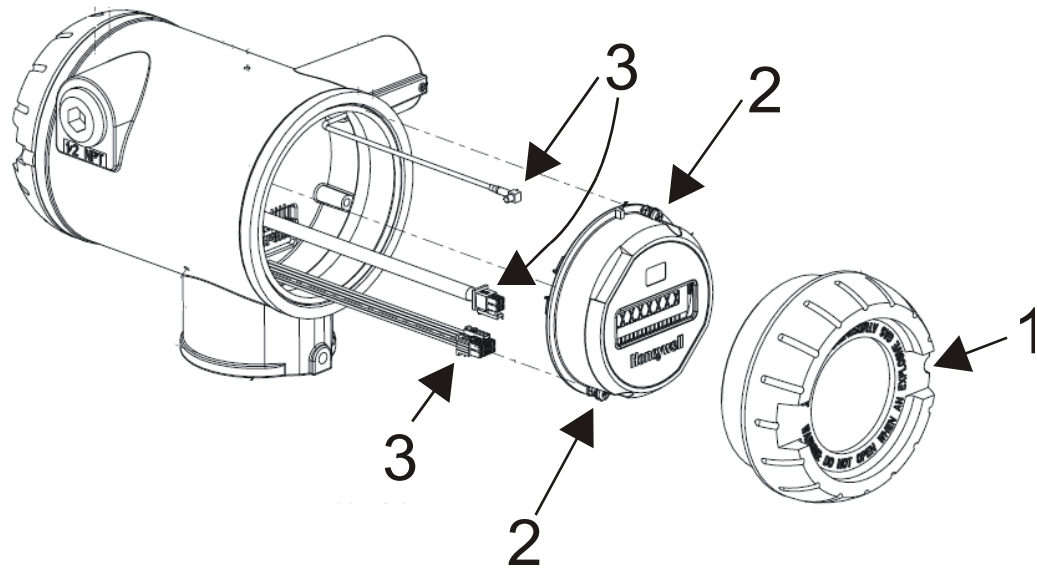

Figure 9 Sensor module removal and replacement

6.5 Replacing batteries

When to replace

When the transmitter displays a LOW BAT message you have 2-4 weeks to replace both batteries before they expire. When batteries are removed or expired, all transmitter data is retained in the transmitter's non-volatile memory.

Tools required

- #1 Phillips Screwdriver or 1/8" Slotted Screwdriver
- Torque Screwdriver
- 1.5 mm hex key

Procedure



ATTENTION

Batteries must be replaced only by a trained service technician.



WARNINGS

- Risk of death or serious injury by explosion. Do not open transmitter enclosure when an explosive gas atmosphere is present.
 - Batteries must not be changed in an explosive gas atmosphere.
 - If IS Battery Pack, Honeywell 50047517-001, has been installed in the Wireless Transmitter, the transmitter enclosure maybe opened when an explosive gas atmosphere is present. Otherwise, do not open transmitter enclosure when and explosive gas atmosphere is present.

- When not in use the Battery Pack must be stored in a non Hazardous Area
 - The batteries used in this device may present a risk of fire or chemical burn if mistreated. Do not recharge, disassemble, heat above 100°C (212°F), or incinerate.
 - When installing batteries, do not snag the battery terminal on the clip or the battery may be damaged. Do not apply excessive force.
 - Do not drop. Dropping the battery may cause damage. If a battery is dropped, do not install the dropped battery into the transmitter. Dispose of dropped battery promptly per local regulations or per the battery manufacturer's recommendations.
-



SHOCK HAZARD

Depending on your installation, transmitter input wiring sources may contain high voltage. Disconnect all power from transmitter input sources before accessing the batteries. Failure to do so could result in death or serious injury if the input terminals or wires are accidentally touched.

IS Battery Pack, 50047517-501

Table 12: IS Battery Pack replacement procedure

Step	Action
1	WARNING  DO NOT DISASSEMBLE OR ASSEMBLE WHEN AN EXPLOSIVE ATMOSPHERE IS PRESENT

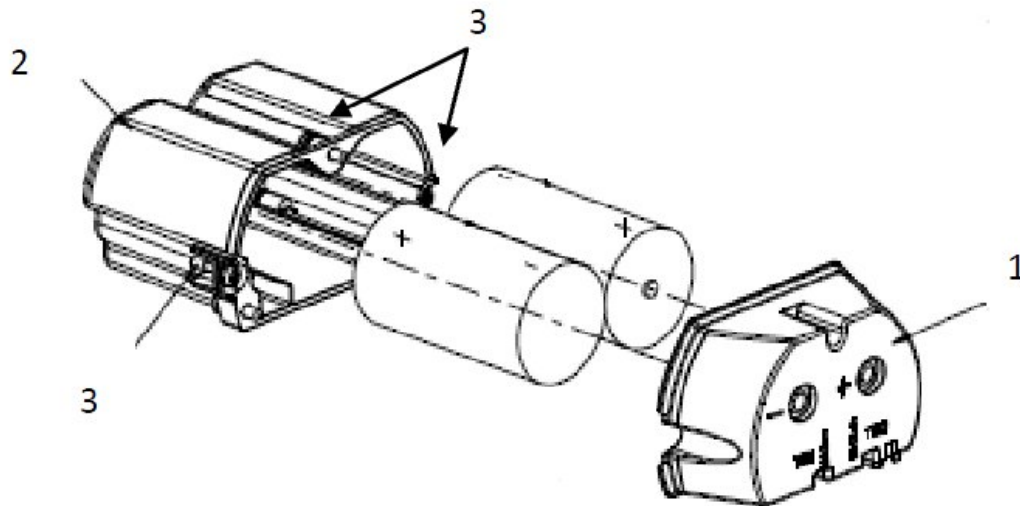

Figure 10: IS Battery Pack

- 2 Loosen the M3 locking set screw on the battery end-cap (opposite end from display). See item 1 in Figure 1. Unscrew and remove the end cap.
- 3 Using thumb and forefinger, squeeze the battery connector at top and bottom to disengage the locking mechanism, then pull to disconnect. See item 2 in Figure 1.
- 4 Loosen the two battery holder retaining screws (closest to the batteries). See item 3 in Figure 1. The screws are captive.
- 5 Pull the battery holder out of the transmitter.
- 6 Remove top of battery pack by using a #1 Philips or 1/8" slotted screwdriver for the screws identified as #3 in Figure 10.
- 7 Remove the old batteries and dispose of them promptly according to local regulations of the battery manufacturer's recommendations.
- 8 Install the batteries following the polarity as noted on the lid
- 9 Re-install top of the battery pack and tighten screws
- 10 Insert the Battery pack into the transmitter. Reattach the screws as indicated in Figure 10, item 3, to 0.4 to 0.6 N-M (3.5 – 5.3 Lb-in).
Reconnect the Battery Pack connector
Honeywell recommends lubricating the end cap with a silicone grease such as Dow Corning #55 or equivalent before replacing the end cap
- 11 Screw the cap back on and tighten the M3 locking screw

6. Maintenance/Repair

6.6. Replacing 24V external power module

6.6 Replacing 24V external power module

When to replace

When the transmitter displays LOW PWR and external power is present and sufficient. When the external power is removed to allow replacement of the module, all transmitter data is retained in the transmitter's nonvolatile memory.

Tools required

- #1 Phillips Screwdriver or 1/8" Slotted Screwdriver
- Torque Screwdriver
- 1.5 mm hex key

Procedure



ATTENTION

24V power module must be replaced only by a trained service technician.



WARNINGS

- Risk of death or serious injury by explosion. Do not open transmitter enclosure when an explosive gas atmosphere is present.
-



SHOCK HAZARD

- Depending on your installation, transmitter input wiring sources may contain high voltage. Disconnect all power from transmitter input sources before accessing the 24V power module. Failure to do so could result in death or serious injury if the input terminals or wires are accidentally touched.
-

Figure 11 24V Power Supply Module Assembly

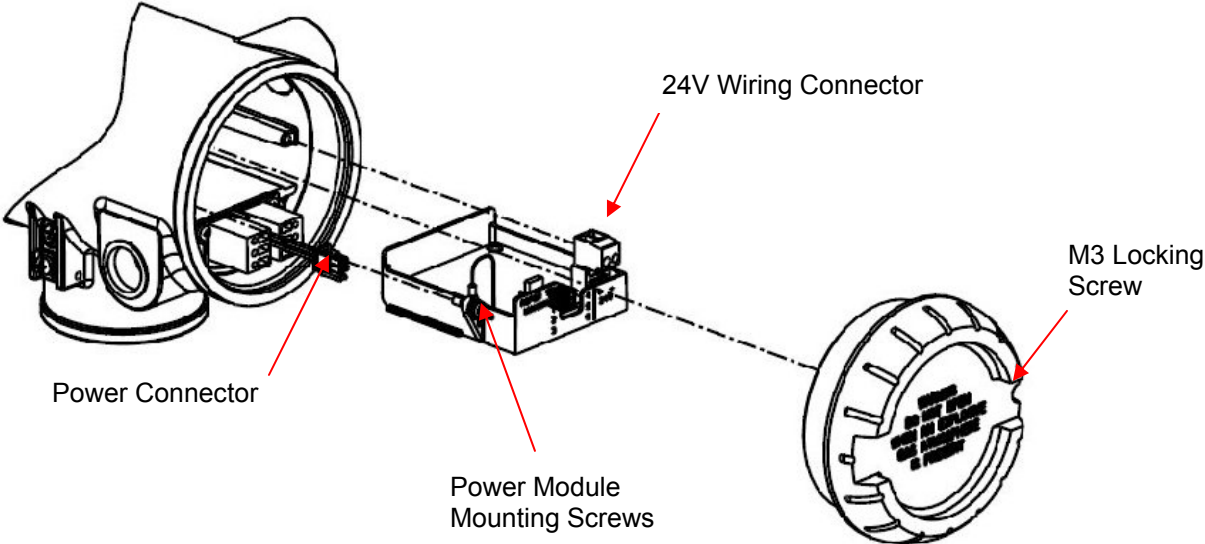
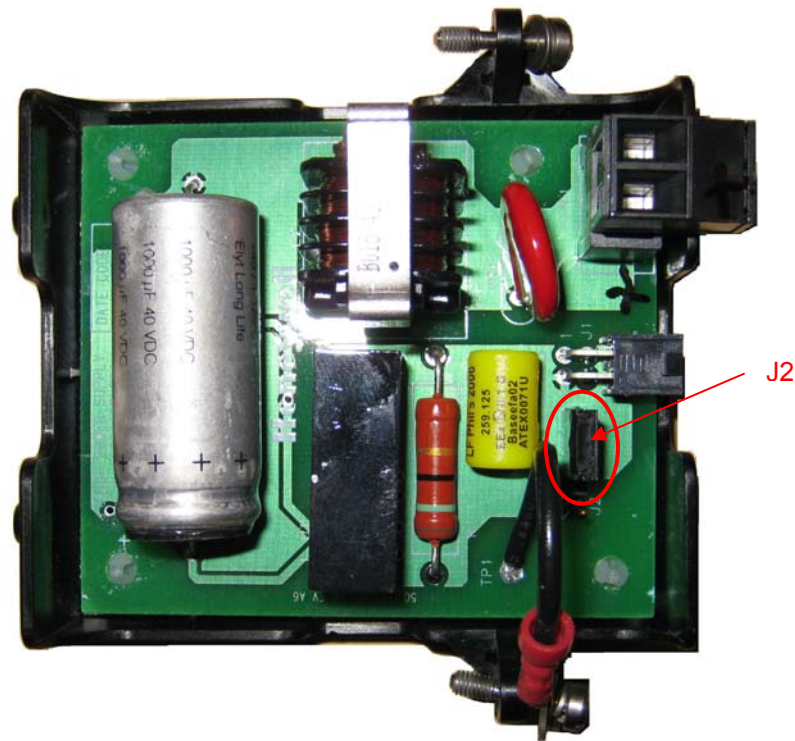

Table 13 24V External power module



Step	Action
1	Loosen the M3 locking set screw on the end-cap (opposite end from display). See Figure 10. Unscrew and remove the end cap.
2	Using thumb and forefinger squeeze the power connector at top and bottom to disengage the locking mechanism then pull to disconnect. See Figure 10.
3	Unplug the 24V wiring from the module
4	Loosen the two 24V power module retaining screws. The screws are captive.
5	Pull the 24V power module out of the transmitter.
6	The replacement 24V Power Modules are supplied with the “J2” Jumper in the NON-RTD position. For 24V Transmitters utilizing RTD sensors, move the “J2” jumper to the “RTD” position on the power module shown above in Table 13.
7	Insert the replacement 24V power module into the transmitter. Reattach the screws and tighten to 0,4 – 0,6 N-M (3.5 – 5.3 Lb-in). Re-connect battery connector.
	Honeywell recommends lubricating the end cap O-ring with a Silicone Grease such as Dow Corning #55 or equivalent before replacing the end cap.
8	Screw the end cap back on and tighten the M3 locking screw.
9	Dispose of the Power Module according to local regulations

6.7 Replacing antenna

Tools required

- #1 Phillips Screwdriver or 1/8" Slotted Screwdriver
- Torque Screwdriver
- 1.5 mm hex key

Procedure



ATTENTION

You must replace your antenna with the same type, that is, elbow, straight, or remote. Changing to a different antenna type is not permitted by approval agencies.



CAUTION

Take precautions against electrostatic discharge to prevent damaging the sensor module.



WARNING

POTENTIAL ELECTROSTATIC CHARGING HAZARD

The integrally mounted antenna shroud is made of Teflon® and has a surface resistance greater than 1G ohm per square. When the XYR 6000 transmitter is installed in potentially hazardous locations care should be taken not to electrostatically charge the surface of the antenna shroud by rubbing the surface with a cloth, or cleaning the surface with a solvent. If electrostatically charged, discharge of the antenna shroud to a person or a tool could possibly ignite a surrounding hazardous atmosphere.

Table 14 Antenna replacement procedure

Step	Action
1	Honeywell recommends that the transmitter be removed from service and moved to a clean area before servicing.
2	Loosen the M3 locking set screw on the display end-cap. See item 1 in Figure 12. Unscrew and remove the front end cap.
3	Loosen the two screws on the sensor module. See items 2 in Figure 12.
4	Remove the sensor module from the transmitter body and disconnect the antenna connector from CN2 connector on the sensor module. See item 3 in Figure 12.
5	Loosen the locking set screw at the antenna base. Unscrew the antenna from the transmitter. Remove the antenna and its connector from the transmitter. See Figure 12.
6	Feed the new antenna's connector through the antenna hole to the front of the transmitter. Do not connect to sensor module yet. Lubricate O-ring with a Silicone Grease such as Dow Corning #55 Screw new antenna into transmitter body until finger-tight, then back off 180 degrees to permit adjustment later.
7	Attach antenna connector to CN2 connector on sensor module. See item 3 in Figure 12.
8	Insert sensor module. Orient in the proper viewing orientation before tightening two sensor compartment screws. See items 2 in Figure 12. Torque screws to 0,4 – 0,6 N-M (3.5 – 5.3 Lb-in).
9	Replace the front end cap. Honeywell recommends lubricating the front end cap O-ring with a Silicone Grease such as Dow Corning #55 or equivalent before replacing the end cap.
10	Adjust antenna for best reception. Don't rotate antenna more than 180 degrees either direction or you could twist and break the antenna wiring inside. Tighten the antenna locking set screw.

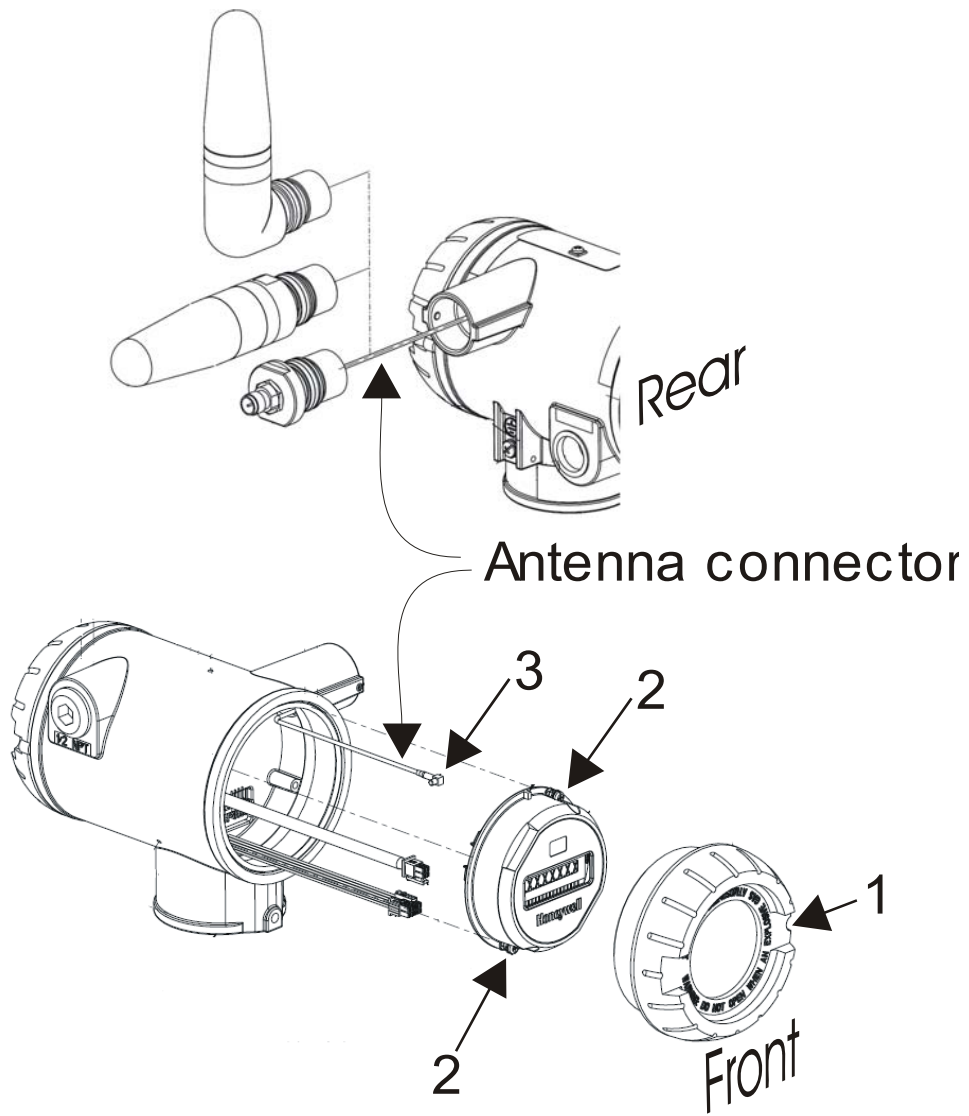

Figure 12 Antenna replacement

6.8 Parts

Transmitter body

The following replacement parts may be ordered from Honeywell.

Part number	Qty.	Description
50015866-502	1	ELECTRONICS MODULE ASSEMBLY aka SENSOR MODULE for Pressure
50015866-506	1	ELECTRONICS MODULE ASSEMBLY aka SENSOR MODULE for Pressure-Intrinsically Safe
50015866-510	1	ELECTRONICS MODULE ASSEMBLY aka SENSOR MODULE for Pressure-DSSS Intrinsically Safe
50015623-501	1	CAP ASSEMBLY, BATTERY, ALUMINUM, DARK BEIGE
50016190-501	1	CAP ASSEMBLY, LCD, ALUMINUM, DARK BEIGE
50026009-501	1	CAP ASSEMBLY, BATTERY, STAINLESS STEEL
50026127-501	1	CAP ASSEMBLY, LCD, STAINLESS STEEL
50016229-501	1	ANTENNA ASSEMBLY, 2 dBi INTEGRAL RIGHT-ANGLE, ALUMINUM
50016229-502	1	ANTENNA ASSEMBLY, 2 dBi INTEGRAL RIGHT-ANGLE, STAINLESS STEEL
50020767-501	1	ANTENNA ASSEMBLY, 2 dBi INTEGRAL STRAIGHT, STAINLESS STEEL
50020767-502	1	ANTENNA ASSEMBLY, 2 dBi INTEGRAL STRAIGHT, ALUMINUM
50031715-501	1	ANTENNA ASSEMBLY, 4 dBi INTEGRAL RIGHT-ANGLE, ALUMINUM
50031715-502	1	ANTENNA ASSEMBLY, 4 dBi INTEGRAL RIGHT-ANGLE, STAINLESS STEEL
50018414-001	1	REMOTE OMNI-DIRECTIONAL ANTENNA, 8 dBi
50018415-001	1	REMOTE DIRECTIONAL ANTENNA, 14 dBi
50016577-502	1	ANTENNA ADAPTER ASSEMBLY, REMOTE, TYPE TNC, ALUMINUM
50028364-501	1	ANTENNA ADAPTER ASSEMBLY, REMOTE, TYPE N, ALUMINUM
50028364-502	1	ANTENNA ADAPTER ASSEMBLY, REMOTE, TYPE N, STAINLESS STEEL
50018110-001	1	COAX CABLE ASSY, 1.0M (3.3 Ft) LONG, RP-TNC - N-MALE
50018110-002	1	COAX CABLE ASSY, 3.0M (10.0 Ft) LONG, RP-TNC - N-MALE
50018110-003	1	COAX CABLE ASSY, 10.0M (33.0 Ft) LONG, RP-TNC - N-MALE
50018278-001	1	COAX CABLE ASSY, 1.0M (3.3 Ft) LONG, N-MALE - N-MALE
50018278-002	1	COAX CABLE ASSY, 3.0M (10.0 Ft) LONG, N-MALE - N-MALE
50018278-003	1	COAX CABLE ASSY, 10.0M (33.0 Ft) LONG, N-MALE - N-MALE
50018279-090	1	LIGHTNING SURGE ARRESTOR
50047517-501	1	I.S. BATTERY PACK HOUSING ASSEMBLY
50031428-501	1	24V EXTERNAL POWER MODULE
50026010-001	2	3.6V LITHIUM THIONYL CHLORIDE (Li-SOCI ₂) BATTERY
50026010-002	4	3.6V LITHIUM THIONYL CHLORIDE (Li-SOCI ₂) BATTERY
50026010-003	10	3.6V LITHIUM THIONYL CHLORIDE (Li-SOCI ₂) BATTERY

Meter body

Use the following figures and table to find replacement parts.

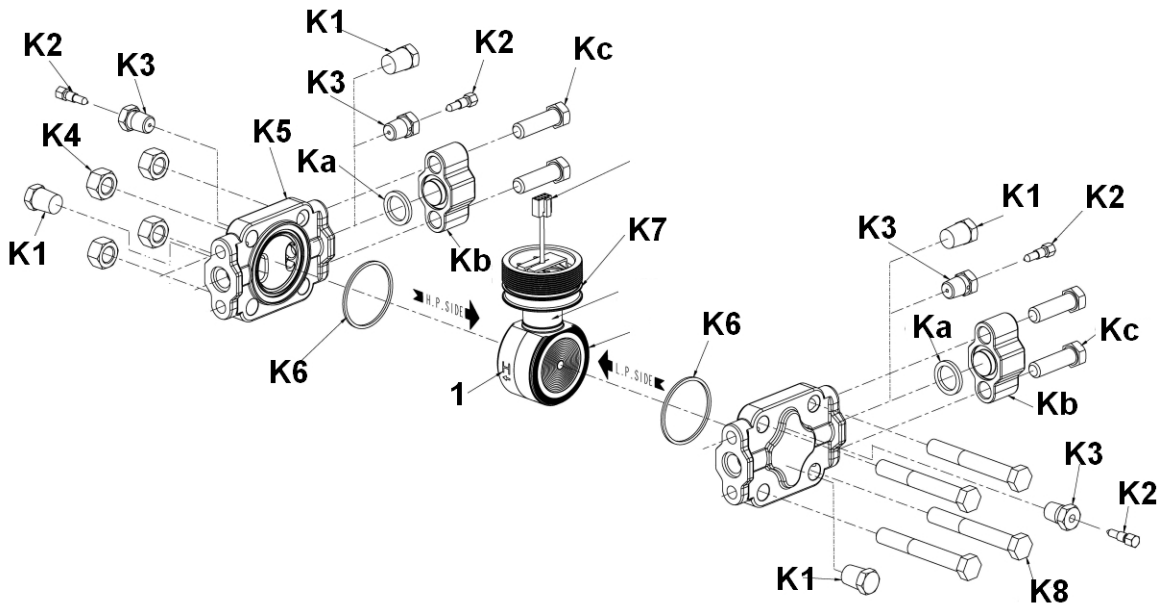

Figure 13 STDW924, STDW930, STDW974

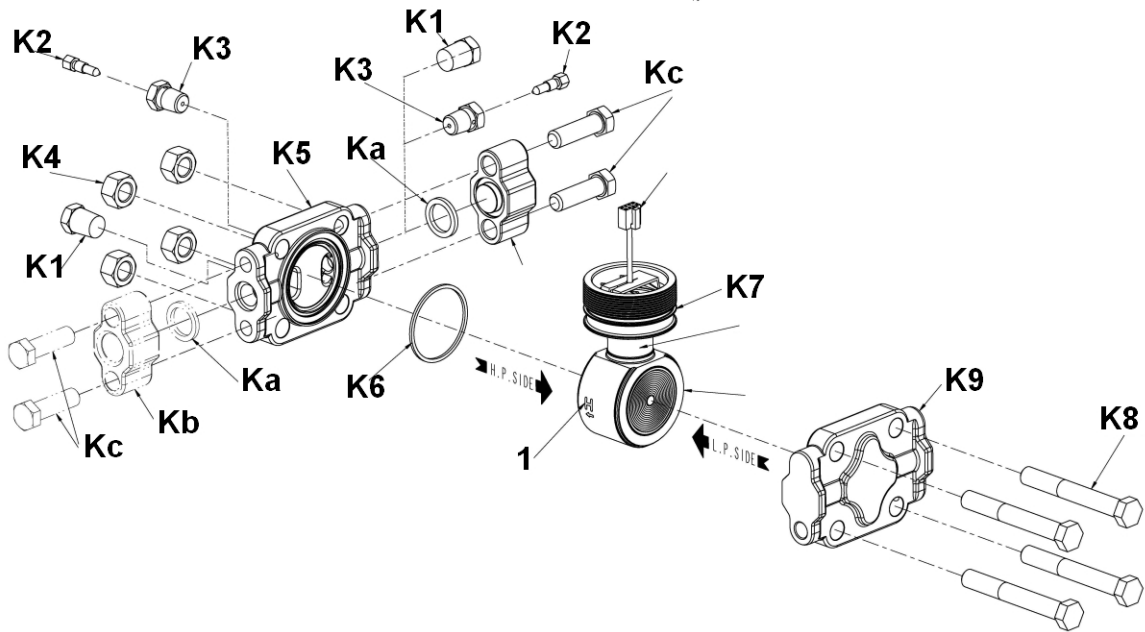

Figure 14 STGW944, STGW974

6. Maintenance/Repair

6.8. Parts

Table 15 Parts (see Figure 13, Figure 14)

Key No.	Part Number	Description	Qty/ Unit
1	Specify complete model number from nameplate	Series 100 Meter Body replacement kit includes: Meter body (without Process Heads) Neoprene O-ring, Meter Body to Electronic Housing (K7 ; Part no. 30752785-009; 1/unit) Process Head Gasket; PTFE (K6 ; Part No. 51452560-002; 2/unit)	1
	Specify complete model number from nameplate	Series 900 Meter Body replacement kit includes: Meter body (without Process Heads) Neoprene O-ring, Meter Body to Electronic Housing (K7 ; Part no. 30752785-009; 1/unit) Process Head Gasket; PTFE (K6 ; Part No. 51452560-002; 2/unit)	1
		Bolting Kits:	
Kc K4 K8	51452866-001	Bolts and Nuts Kit, Carbon Steel	
	51452866-002	Bolts A286 SS (NACE) and Nuts, 304 SS (NACE) Kit	
	51452866-003	Bolts, 316 SS (non-NACE) and Nuts, 316 SS (non-NACE) Kit	
	51452866-004	Bolts B7M and Nuts 7M Kit	
	Each Bolts and Nuts Kit includes: Bolt, Hex head, 7/16-20 UNF, 1.50 Inches long (Flange Adapter).....	4
	Nut, Hex, 7/16 UNC (Process Head).....	4
	Bolt, Hex Head, 7/16 UNC X 3.25 inches long (Process Head).....	4
		Vent and Plug Kits:	
K1 K2 K3	30753785-001	Drain and Plug Kit, stainless steel	
	30753787-001	Drain and Plug Kit, Monel	
	30753786-001	Drain and Plug Kit, Hastelloy C	
	Each Drain and Plug Kit includes: Pipe Plug	4
	Vent Plug	2
	Vent Bushing	2
		Meterbody Gasket Kits:	
K6 Ka K7	51452865-001	Meterbody Gasket Kit (PTFE Material); Kit includes:	
	51452865-002	Meterbody Gasket Kit (Viton Material); Kit includes:	
	Gasket, Process Head	6
	Gasket, Flange Adapter	6
	30757503-003	O-Ring, Meterbody to Electronics Housing	3

Key No.	Part Number	Description	Qty/ Unit
		Process Head Gasket Kits:	
K6	51452868-001	Gasket only, Process Head (12 PTFE Gaskets/pack)	12
K6	51452868-002	Gasket only, Process Head (6 Viton Head O-Rings)	6
K6	51452868-007	Gasket only, Process Head Graphite Gasket (use only as replacement of existing graphite gasket)	6
		Flange Adapter Gasket Kits:	
Ka	51452868-004	Gasket only, Flange Adapter, 6 PTFE Adapter Gaskets	6
Ka	51452868-005	Gasket only, Flange Adapter, 6 VITON Adapter O-Rings	6
Ka	51452868-078	Gasket only, Flange Adapter Graphite Gasket (use only as replacement of existing graphite gasket)	6
		½ inch NPT Flange Adapter Kits:	
	51452867-110	Flange Adapter Kit, with: SS Flange Adapters and with carbon steel bolts	
	51452867-210	SS Flange Adapters and with A286 SS (NACE) bolts	
	51452867-310	SS Flange Adapters and with 316 SS (non-NACE) bolts	
	51452867-410	SS Flange Adapters and with B7M alloy steel bolts	
	51452867-150	Monel Flange Adapters and with carbon steel bolts	
	51452867-350	Monel Flange Adapters and with 316 SS (non-NACE) bolts	
	51452867-130	Hastelloy C Flange Adapters and with carbon steel bolts	
	51452867-330	Hastelloy C Flange Adapters and with 316 SS (non-NACE) bolts	
		Each 1/2-inch NPT Flange Adapter Kit includes:	
Ka	Gasket, Flange Adapter	2
Kb	1/2-inch NPT Flange Adapter	2
Kc	Bolt, hex head, 7/16-20 UNF, 1.50 inches long, Flange Adapter ..	4
		Blind Flange Adapter Kits:	
	51452867-100	SS Blind Flange Adapter Kit, with Carbon Steel bolts	
	51452867-200	SS Blind Flange Adapter Kit, with A286 SS (NACE) bolts	
	51452867-300	SS Blind Flange Adapter Kit, with 316 SS (non-NACE) bolts	
	51452867-400	SS Blind Flange Adapters and B7M alloy steel bolts	
		Each Blind Flange Adapter Kit includes:	
Ka	Gasket, Flange Adapter	2
Kb	Blind Flange Adapter	2
Kc	Bolt, hex head, 7/16-20 UNF, 1.50 inches long, Flange Adapter ..	4

6. Maintenance/Repair

6.8. Parts

Key No.	Part Number	Description	Qty/ Unit
		Process Head Kits:	
	51452864-010 51452864-012	Process Head Assembly Kit, with PTFE Gasket and with: Carbon steel head (zinc plated) without side vent/drain Carbon steel head (zinc plated) with side vent/drain	
	51452864-020 51452864-022	Stainless steel head without side vent/drain Stainless steel head with side vent/drain	
	51452864-030 51452864-032	Hastelloy C head without side vent/drain Hastelloy C head with side vent/drain	
	51452864-040 51452864-042	Monel head without side vent/drain Monel head with side vent/drain	
	51452864-050 51452864-052	Carbon steel head (nickel plated) without side vent/drain Carbon steel head (nickel plated) with side vent/drain	
	51452864-110 51452864-112	Process Head Assembly Kit, with VITON Gasket and with: Carbon steel head (zinc plated) without side vent/drain Carbon steel head (zinc plated) with side vent/drain	
	51452864-120 51452864-122	Stainless steel head without side vent/drain Stainless steel head with side vent/drain	
	51452864-130 51452864-132	Hastelloy C head without side vent/drain Hastelloy C head with side vent/drain	
	51452864-140 51452864-142	Monel head without side vent/drain Monel head with side vent/drain	
	51452864-150 51452864-152	Carbon steel head (nickel plated) without side vent/drain Carbon steel head (nickel plated) with side vent/drain	
K1	Each Process head Assembly Kit includes: Pipe Plug (See Note 1, 2.).....	2
K2	Vent Plug (See Note 1.).....	1
K3	Vent Bushing (See Note 1.).....	1
K5	Process Head	1
K6	Gasket (PTFE), Process Head	1
Ka	Gasket (PTFE), Flange Adapter.....	1
		NOTE 1 : This item is made of the same material as the Process Heads, except for Kits with carbon steel Process Heads, which include stainless steel Pipe Plug, Vent Plug, and Vent Bushing. NOTE 2: The Kit for Process Heads without side vent/drain does not include Pipe Plugs (K1).	
		Reference Head:	
K9	51452951-001	Carbon Steel Blind Reference Head	1
K9	51452951-002	316 SS Blind Reference Head (Model Selection Guide HR Option)	1

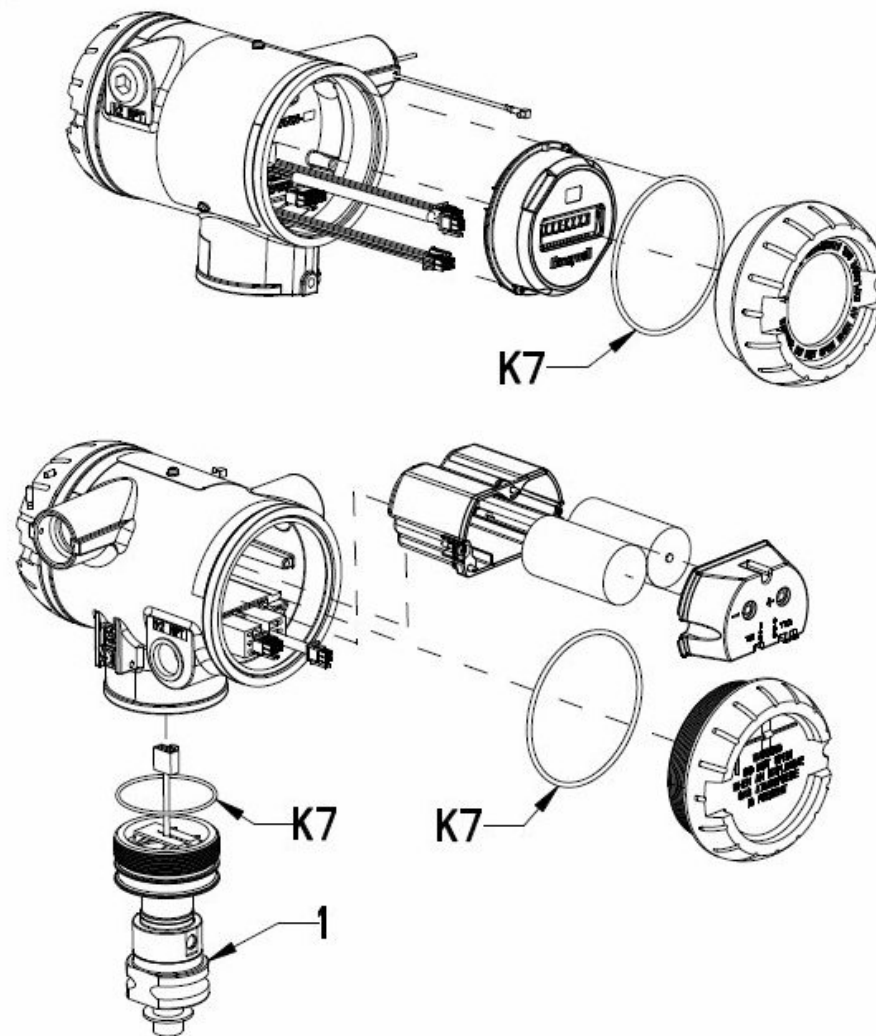

Figure 15 GP/AP models STGW94L, STGW97L, STGW98L, STGW99L, STAW94L

Table 16 Parts

Key No.	Part Number	Description	Qty/ Unit
1	Specify complete model number from nameplate	Meter Body replacement kit includes: Meter body	1
K7	30757503-001	Electronics enclosure seals kit for LGP/LAP models. Kit includes: O-ring for transmitter end caps O-ring, meter body to electronics housing	6 3

6.9 Dimension drawings

Dimension drawings are available for each transmitter model. If you need a copy of a drawing, please determine the appropriate drawing number from the following tables and contact your Honeywell representative.

Table 17 Drawing numbers for DP models STDW924, STDW930, STDW974

Angle Bracket ("MB" or "SB")		Flat Bracket ("FB")	
Vertical Pipe	Horizontal Pipe	Vertical Pipe	Horizontal Pipe
50022275	50022274	50022273	50022272

Table 18 Drawing numbers for DHGP models STGW944, STGW974

Angle Bracket ("MB" or "SB")		Flat Bracket ("FB")	
Vertical Pipe	Horizontal Pipe	Vertical Pipe	Horizontal Pipe
50022279	50022278	50022277	50022276

Table 19 Drawing numbers for GP/AP models STGW94L, STGW97L, STGW98L, STAW94L, STGW99L

Angle Bracket ("MB" or "SB")		Flat Bracket ("FB")	
Vertical Pipe	Horizontal Pipe	Vertical Pipe	Horizontal Pipe
50022287	50022286	50022285	50022284

Sales and Service

For application assistance, current specifications, pricing, or name of the nearest Authorized Distributor, contact one of the offices below.

ASIA PACIFIC

(TAC)

hfs-tac-support@honeywell.com

Australia

Honeywell Limited
Phone: +(61) 7-3846 1255
FAX: +(61) 7-3840 6481
Toll Free 1300-36-39-36
Toll Free Fax:
1300-36-04-70

China – PRC - Shanghai

Honeywell China Inc.
Phone: (86-21) 5257-4568
Fax: (86-21) 6237-2826

Singapore

Honeywell Pte Ltd.
Phone: +(65) 6580 3278
Fax: +(65) 6445-3033

South Korea

Honeywell Korea Co Ltd
Phone: +(822) 799 6114
Fax: +(822) 792 9015

EMEA

Phone: + 80012026455 or +44
(0)1202645583

FAX: +44 (0) 1344 655554

Email: (Sales)

sc-cp-apps-salespa62@honeywell.com

(TAC)

hfs-tac-support@honeywell.com

NORTH AMERICA

Honeywell Process Solutions,

Phone: 1-800-423-9883

Or 1-800-343-0228

Email: (Sales)

ask-ssc@honeywell.com or

(TAC)

hfs-tac-support@honeywell.com

SOUTH AMERICA

Honeywell do Brasil & Cia

Phone: +(55-11) 7266-1900

FAX: +(55-11) 7266-1905

Email: (Sales)

ask-ssc@honeywell.com or

(TAC)

hfs-tac-support@honeywell.com

Honeywell

Honeywell Process Solutions

1860 West Rose Garden Lane
Phoenix, Arizona 85027

www.honeywellprocess.com

34-XY-25-15 Rev.9

January 2012

©2012 Honeywell International Inc.