

Dyna-Star®

HYDRAULIC RECIPROCATOR AND PUMP

312350E

- For lubricating fluids only -

10:1 Ratio Universal Pump and Reciprocator

600 psi (4.1 MPa, 41 bar) Maximum Hydraulic Input Pressure

7500 psi (51 MPa, 517 bar) Maximum Fluid Outlet Pressure

Model 247540: Pump, 60 lb Automatic Lube Pump Module Length

Model 247443: Pump, 120 lb Drum Length

Model 247450: Pump, 400 lb Drum Length



Important Safety Instructions

Read all warnings and instructions in this manual.
Save these instructions.

Table of Contents

Warnings	2
Installation	4
Operation	7
Troubleshooting	9
Service	10
Reciprocator Parts	18
Pump Parts	20
Technical Data	21
Graco Standard Warranty	23
Graco Information	23

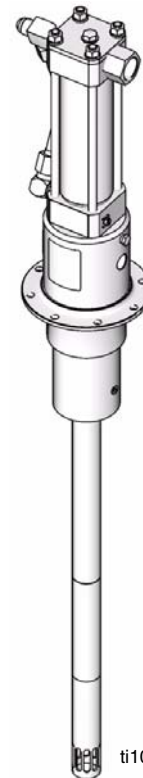









ti10604a

Model 247443 Shown

Warnings

The following warnings are for the setup, use, grounding, maintenance, and repair of this equipment. The exclamation point symbol alerts you to a general warning and the hazard symbol refers to procedure-specific risk. Refer back to these warnings. Additional, product-specific warnings may be found throughout the body of this manual where applicable.

 WARNING	
	<p>FIRE AND EXPLOSION HAZARD</p> <p>When flammable fluids are present in the work area, such as gasoline and windshield wiper fluid, be aware that flammable fumes can ignite or explode. To help prevent fire and explosion:</p> <ul style="list-style-type: none"> • Use equipment only in well ventilated area. • Eliminate all ignition sources, such as cigarettes and portable electric lamps. • Keep work area free of debris, including rags and spilled or open containers of solvent and gasoline. • Do not plug or unplug power cords or turn lights on or off when flammable fumes are present. • Ground all equipment in the work area. • Use only grounded hoses. • If there is static sparking or you feel a shock, stop operation immediately. Do not use equipment until you identify and correct the problem. • Keep a working fire extinguisher in the work area.
	<p>EQUIPMENT MISUSE HAZARD</p> <p>Misuse can cause death or serious injury.</p> <ul style="list-style-type: none"> • Do not operate the unit when fatigued or under the influence of drugs or alcohol. • Do not exceed the maximum working pressure or temperature rating of the lowest rated system component. See Technical Data in all equipment manuals. • Use fluids and solvents that are compatible with equipment wetted parts. See Technical Data in all equipment manuals. Read fluid and solvent manufacturer's warnings. For complete information about your material, request MSDS forms from distributor or retailer. • Check equipment daily. Repair or replace worn or damaged parts immediately with genuine manufacturer's replacement parts only. • Do not alter or modify equipment. • Use equipment only for its intended purpose. Call your distributor for information. • Route hoses and cables away from traffic areas, sharp edges, moving parts, and hot surfaces. • Do not kink or over bend hoses or use hoses to pull equipment. • Keep children and animals away from work area. • Comply with all applicable safety regulations.
	<p>SKIN INJECTION HAZARD</p> <p>High-pressure fluid from dispense valve, hose leaks, or ruptured components will pierce skin. This may look like just a cut, but it is a serious injury that can result in amputation. Get immediate surgical treatment.</p> <ul style="list-style-type: none"> • Do not point dispense valve at anyone or at any part of the body. • Do not put your hand over the end of the dispense nozzle. • Do not stop or deflect leaks with your hand, body, glove, or rag. • Follow Pressure Relief Procedure in this manual, when you stop spraying and before cleaning, checking, or servicing equipment.

 WARNING	
	<p>MOVING PARTS HAZARD</p> <p>Moving parts can pinch or amputate fingers and other body parts.</p> <ul style="list-style-type: none"> • Keep clear of moving parts. • Do not operate equipment with protective guards or covers removed. • Pressurized equipment can start without warning. Before checking, moving, or servicing equipment, follow the Pressure Relief Procedure in this manual. Disconnect power or air supply.
	<p>BURN HAZARD</p> <p>Equipment surfaces and fluid that's heated can become very hot during operation. To avoid severe burns, do not touch hot fluid or equipment. Wait until equipment/fluid has cooled completely.</p>
	<p>TOXIC FLUID OR FUMES HAZARD</p> <p>Toxic fluids or fumes can cause serious injury or death if splashed in the eyes or on skin, inhaled, or swallowed.</p> <ul style="list-style-type: none"> • Read MSDS's to know the specific hazards of the fluids you are using. • Store hazardous fluid in approved containers, and dispose of it according to applicable guidelines. • Always wear impervious gloves when spraying or cleaning equipment.
	<p>PERSONAL PROTECTIVE EQUIPMENT</p> <p>You must wear appropriate protective equipment when operating, servicing, or when in the operating area of the equipment to help protect you from serious injury, including eye injury, inhalation of toxic fumes, burns, and hearing loss. This equipment includes but is not limited to:</p> <ul style="list-style-type: none"> • Protective eyewear • Clothing and respirator as recommended by the fluid and solvent manufacturer • Gloves • Hearing protection

Installation

Typical Installation of a Suction Feed System

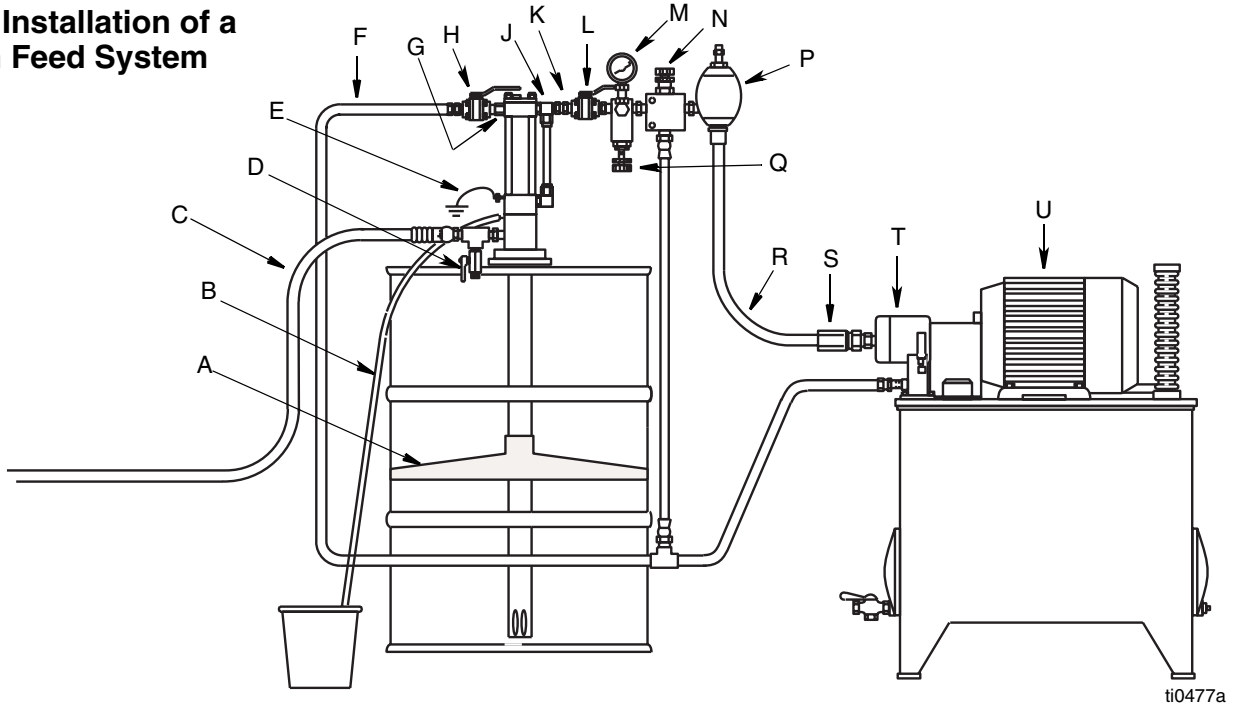

Key:

- A Follower plate
- B Weep tube
- C Fluid outlet line (to gun)
- D Drain valve (required)
- E Ground wire
- F Hydraulic return line, minimum 3/4 inch I.D. (required)
- G Hydraulic outlet, 3/4" npt (f)
- H Return line shut-off valve, minimum 3/4 inch (required)
- J Hydraulic inlet, 3/4" npt (m)
- K Tee, 3/4" npt
- L Supply line shut-off valve (required)
- M *Pressure gauge
- N *Pressure reducing valve (required in systems over 600 psi [4.1 MPa, 41 bar])
- P Accumulator
- Q *Flow control valve (required in systems over 3 gpm [11 lpm])
- R Hydraulic supply line
- S Check valve
- T Variable volume pressure compensated pump
- U Hydraulic power supply
- V Drain line, accumulator

*Included in Hydraulic Fluid Control Kit 247538 or 247705, which can be ordered separately.

FIG. 1

Although the installation shown in FIG. 1 is only a guide for selecting and installing system components and accessories, some of the equipment is required, as noted in the key. For assistance in designing a system to suit your needs, contact your Graco distributor. Mount pump to suit the type of installation planned.

CAUTION

Do not operate pump without it being securely mounted to a drum cover or support.

--	--	--	--

Maximum Working Pressure of Accessories
 To reduce the risk of serious injury including fluid injection and splashing in the eyes or on the skin which may be caused if component ruptures, all accessories added to the reciprocator power supply side must have at least 600 psi (4.1 MPa, 41 bar) maximum working pressure.

All accessories added to the pump fluid outlet side must have at least 7500 psi (51 MPa, 517 bar) maximum working pressure.

Pump Accessories

Follower Plate (A): ensures a good prime. Place follower plate on grease and rotate while pressing firmly to level material. Order part number 247700 for 60# and 90# automatic lube pump modules; 247701 for 120# refinery reservoir; or 247702 for 400# refinery reservoir.



Pump Outlet Drain Valve

- A pump outlet drain (D) is required in your system. This valve helps relieve pressure in the displacement pump and hose when shutting down system and in case of a clogged outlet hose. Install valve close to pump outlet.
- Mount pump securely so it cannot move around during operation. Failure to do so could result in personal injury and/or equipment damage.

Pump Outlet Drain Valve (D): helps relieve fluid pressure in pump when pump is shut off. Install valve close to pump fluid outlet. Order valve, Part No. 111229.

Hydraulic Power Supply

See FIG. 1.



Limit Fluid Flow to Reciprocator

To reduce the risk of overpressurizing the hydraulic reciprocator which could cause a rupture and serious injury, including fluid injection, a hydraulic system must have a means to limit the incoming fluid flow to the reciprocator to a maximum of 3 gpm (11 lpm) and 600 psi (4.1 MPa, 41 bar). See description below.

The hydraulic power supply system (U) must have a pressure reducing valve and a pressure-compensated flow control. A flow control valve (Q) is required to limit the incoming flow to the reciprocator to a *maximum of 3 gpm (11 lpm)*.

 Pressure gauge (M), pressure reducing valve (N) and a flow control valve (Q) are included in the Hydraulic Fluid Control Kit 247538 or 247705, which can be ordered separately.

Hydraulic Lines

Shut-off Valves (H, L): installed on the hydraulic supply and return lines. Order Part No. 108537 and 112578.

Drain Line: Monitor the weepage of hydraulic fluid or lubricant. If it seems excessive or increases suddenly, the reciprocator/pump seals may need to be changed. See FIG. 2.

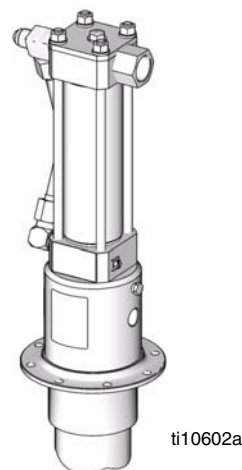

FIG. 2

Hoses: Use a minimum 1/2 inch supply line (R) and minimum 3/4 inch return line (F) on the reciprocator. Contact your Graco representative for details of line sizing.

Pressure Reducing Valve (N): circulates excess hydraulic fluid pressure back to the hydraulic power supply. Install this valve (N) in the hydraulic supply line with a drain hose (W) teed into the hydraulic return line (F). Limit supply pressure to a maximum 600 psi (4.1 MPa, 41 bar).

Accumulator (P): reduces hammering effect caused by the motor when it reverses direction.

Fluid-filled Pressure Gauge (M), Part No. 112567: monitors hydraulic pressure to the reciprocator during startup. See FIG. 1. Use the gauge for initial adjustment of the reciprocator. It can be removed after adjustment.

Grounding

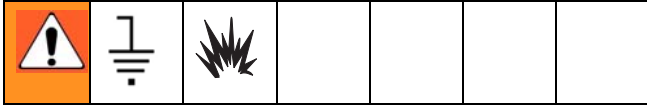

To reduce the risk of static sparking, ground pump. Check your local electrical code for detailed grounding instructions for your area and type of equipment.

- **Pump:** Use ground wire and clamp as shown in FIG. 3. Order Grounding Wire and Clamp Kit, Part No. 222011.
- **Hydraulic Hoses and Fluid Outlet Hoses:** Use electrically conductive hoses only.
- **Hydraulic Power Supply:** Follow manufacturer's recommendations.
- **Flushing Pails:** When flushing, only use metal, grounded pails. Make firm, metal-to-metal contact between the metal part of the dispense valve and the pail. Use lowest possible pressure.

Grounding the Pump

To ground pump (See FIG. 3):

1. Remove ground screw (Z) and insert through eye of ring terminal at end of ground wire.
2. Fasten ground screw back onto pump and tighten securely.
3. Connect other end of wire to a true earth ground.

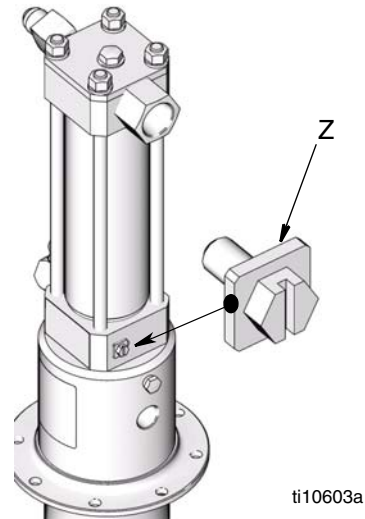

FIG. 3

ti10603a

Operation

Pressure Relief Procedure



The system pressure must be manually relieved to prevent the system from starting or dispensing accidentally. Follow this pressure relief procedure whenever you are instructed to:

- relieve pressure.
- check or service any system equipment.
- install or clean nozzle.

For the following instructions, see FIG. 1.

1. Shut off hydraulic power supply.
2. Close supply line shut-off valve (L).
3. Open dispensing valve to relieve pressure.
4. Open pump outlet drain valve. Have a container ready to catch drainage.
5. Close return line shut-off valve (H).

 Leave drain valve open until you are ready to dispense again.

*If you suspect the nozzle or hose is completely clogged or that pressure has not been fully relieved after following steps 1-5 above, **very slowly** loosen the hose end coupling to relieve pressure, then clear obstruction.*

Before Starting Pump



COMPONENT RUPTURE HAZARD

Overpressurizing any component can result in serious injury or property damage as a result of rupture, fire, and/or explosion. The maximum working pressure of each component in the system may not be the same. To reduce the risk of overpressurizing any component in the system:

- Be sure you know the maximum working pressure of each component.
- **Never** exceed the maximum working pressure of the lowest rated component in the system.
- Do not exceed the maximum pump cycle rate.
- The pump has a rated ratio of 10:1. However, it is capable of reaching stall pressures equal to 12.5 times the hydraulic input pressure. To calculate the fluid output pressure, multiply the hydraulic pressure shown on the hydraulic control module gauge by 12.5.

For example:

$$600 \text{ psi hydraulic} \times 12.5 = 7500 \text{ psi fluid output}$$

$$4.14 \text{ MPa hydraulic} \times 12.5 = 51.8 \text{ MPa fluid output}$$

$$41.4 \text{ bar hydraulic} \times 12.5 = 518 \text{ bar fluid output}$$



- Regulate hydraulic pressure to the pump so that no fluid line component or accessory is overpressurized.

- Check hydraulic fluid level in hydraulic power supply before each use. Add fluid as necessary to fill the lines.
- Flush pump before using it for the first time to remove the light oil that was left in after factory testing to protect pump from corrosion. Be sure solvent used is compatible with the fluid to be pumped and the pump's wetted parts. See **Technical Data**, page 20. Flush until clean solvent comes out of hose.

Starting Pump

1. Turn on hydraulic power supply.
2. Open return line shut-off valve (H) first, then slowly open the hydraulic supply shut-off valve (L).
3. Adjust flow control valve (Q) to limit the hydraulic flow to no more than 3 gpm (11 lpm), which is approximately 60 cycles per minute.
4. Adjust pressure reducing valve (N) to increase hydraulic inlet pressure from 50 to 600 psi (0.34 to 4.1 MPa, 3.4 to 41 bar).
 - Increasing inlet pressure, increases outlet pressure.
 - Decreasing inlet pressure, decreases outlet pressure.
5. Open drain valve while priming pump.
6. When pump is primed, close drain valve.

Always use lowest pressure possible to obtain desired results. This reduces pump wear.

						
<p>Maximum Working Pressures</p> <p>To reduce the risk of serious injury, including fluid injection and splashing in the eyes or on the skin, which may be caused if a component ruptures:</p> <ul style="list-style-type: none"> • Never exceed <i>600 psi (4.1 MPa, 41 bar) Maximum Hydraulic Pressure</i> to the reciprocator. • Never exceed <i>7500 psi (51 MPa, 517 bar) Maximum Outlet Pressure</i> from the displacement pump. • Accessories added to the pump fluid outlet side should have at least a <i>7500 psi (51 MPa, 517 bar) Maximum Working Pressure</i>. • Read and understand COMPONENT RUPTURE HAZARD instructions, page 7. 						

If the Pump Leaks at the Fluid Fittings

Tighten fittings (1, 5, 60) which are self-sealing and have replaceable o-rings. If leaking persists, change o-rings.

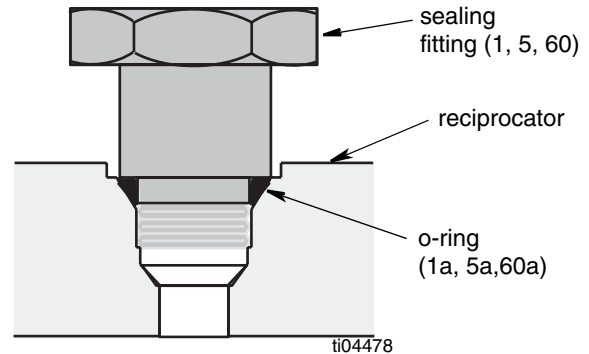

FIG. 4

Shutdown

Relieve pressure, page 7, whenever you shutdown.

Troubleshooting

Problem	Cause	Solution
Pump does not run.	Closed dispense valve.	Pump only runs with valve open.
	Pressure too low.	Increase supply pressure using a pressure adjusting valve.
	Insufficient hydraulic fluid supply.	Check hydraulic supply. Adjust to a maximum of 3 gpm (11 lpm) flow.
	Clogged fluid outlet line, intake valve, dispense valve, suction line.	Relieve pressure , page 7. Check. Clear obstructions.
	Reciprocator damaged.	Repair.
Pump speeds up or runs erratically.	Pump piston and/or intake valve worn.	Relieve pressure , page 7. Check and repair.
	Empty supply container.	Refill and repair. Do not allow pump to run dry. Monitor closely or use a low-level cutoff valve.
Pump runs but output low on up and/or down stroke.	Pump piston and/or intake valve worn.	Relieve pressure , page 7. Check and repair.
Pump run but output low on both up and down strokes.	Insufficient hydraulic fluid supply.	Check hydraulic supply. Adjust to maximum 3 gpm (11 lpm) flow.
	Pressure too low.	Increase supply pressure using a pressure adjusting valve.
	Clogged fluid outlet line, intake valve, dispense valve, suction line.	Relieve pressure , page 7. Check. Clear obstructions.
Excessive weepage from weep tube (B), page 4.	Worn throat packings.	Repair.
	Worn displacement seal.	Repair.
Hydraulic oil leaks from fittings in the upper or lower reciprocator blocks (31, 32) [Parts page 18].	Fittings 1, 5, 58, (Parts, page 18), are loose, or their o-rings are worn or damaged.	Tighten the self-sealing fittings. If leaking persists, change o-rings.

Service

<p>Use of a hydraulic power supply with fluid temperatures above 154°F (68°C) can create hot surfaces which can burn if touched.</p> <ul style="list-style-type: none"> • Do not touch pump, motor, or if hydraulic system fluid is above 154°F (68°C). • Allow sufficient time for pump and motor to cool before attempting any service or repair. 						

Replacing Throat Seals

See FIG. 5.

Replace throat seals if fluid leaks excessively through the weep tube (B), page 4. This procedure can be done without disassembling entire reciprocator.

1. **Relieve pressure**, page 7.
2. Disconnect reciprocator from pump.
3. Remove four capscrews (15) from bottom of adapter (43). Tap adapter to loosen it and pull it off the bottom cap (32).
4. Remove seal (44, included in Reciprocator Repair Kit 247455) from top of adapter (43).
5. Install seal (16) in adapter (43) in the order shown in FIG. 5.
6. Reassemble. Torque the capscrews (15) to 28-32 ft-lb (38 to 43 N.m). Install displacement pump, see Step 23 on page 15.

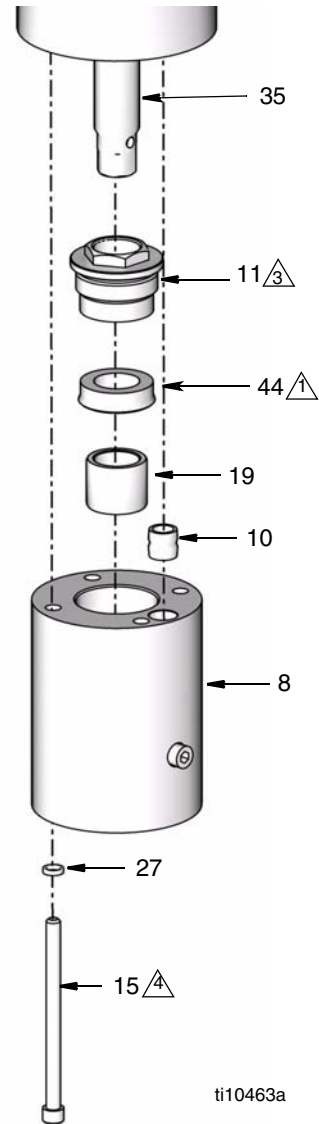

- Lips face down.
- Torque to 54-56 ft-lbs (73-76 N.m).
- Torque to 170 - 180 in-lbs (19-20 N.m)

FIG. 5

Disconnecting Reciprocator and Displacement Pump

See FIG. 6 and Displacement Pump Parts, page 18.

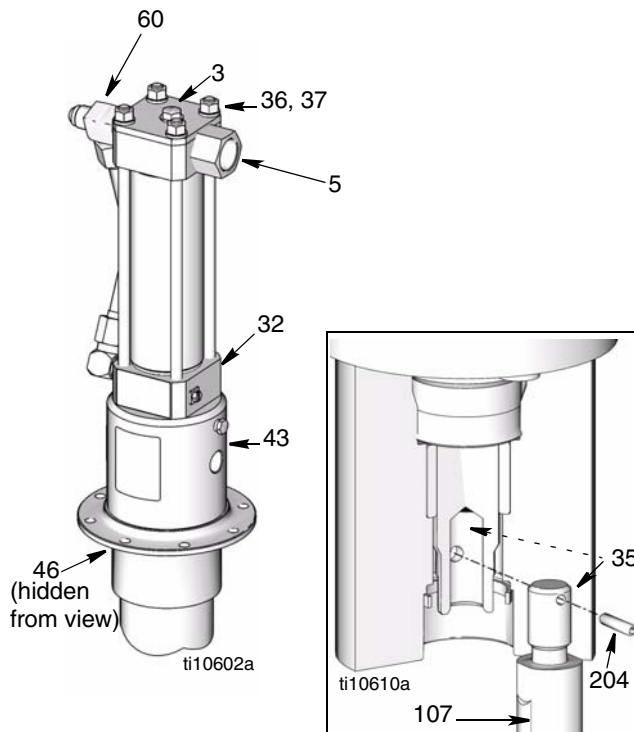

FIG. 6

1. Flush pump if possible and stop it with displacement rod in lowest position.
2. **Relieve pressure**, page 7.
3. Disconnect outlet hose from displacement pump.
4. Slowly loosen hydraulic supply (60) and return (5) fittings to relieve any pressure. Then remove hoses.
5. Install plugs on tube fittings and in hose ends.
6. Check o-rings (5a and 60a) on fittings and replace them if they are worn or damaged. See FIG. 4 and Reciprocator parts drawing, page 18.
7. Using a strap wrench on displacement cylinder (109) screw it out of motor housing (43) and slide it down as far as it will go.
8. Pull connecting rod (35) down as far as it will go. Remove pin (204).
9. Unscrew connecting rod (107) to remove pump.

Reciprocator Repair

See FIG. 7 and FIG. 9 and Reciprocator Parts, page 18.



- Clean and inspect all parts for wear or damage. Replace worn parts as needed. For best results, always replace all the o-rings and seals when you disassemble the pump. **Repair Kit 247455** is available. Parts included in the kit are marked with an asterisk, for example (23*), in the text and drawings. Always replace seals (23* and 24*) and seals (16* and 44*) together.
- Assembly tool 189305 is required for reassembling the reciprocator.
- Loctite® 242 thread sealant and Loctite® Primer T or Perma-Loc® 115 thread sealant and Perma-Bond® Surface Conditioner I are required. Be sure their shelf life is within the manufacturer's recommendations.
- Use Loctite® 609 on yoke (9) and rod (12) on page 13, step 9 only. Use Loctite® 242 or Perma-Loc® 115 on other threaded surfaces as required.

Drain Oil Out of Reciprocator

Before you begin, drain oil out of reciprocator.

1. **Relieve pressure**, page 7.
2. Place reciprocator in a drain pan.

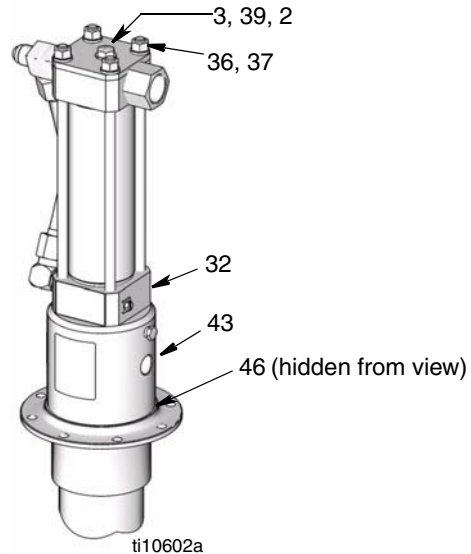
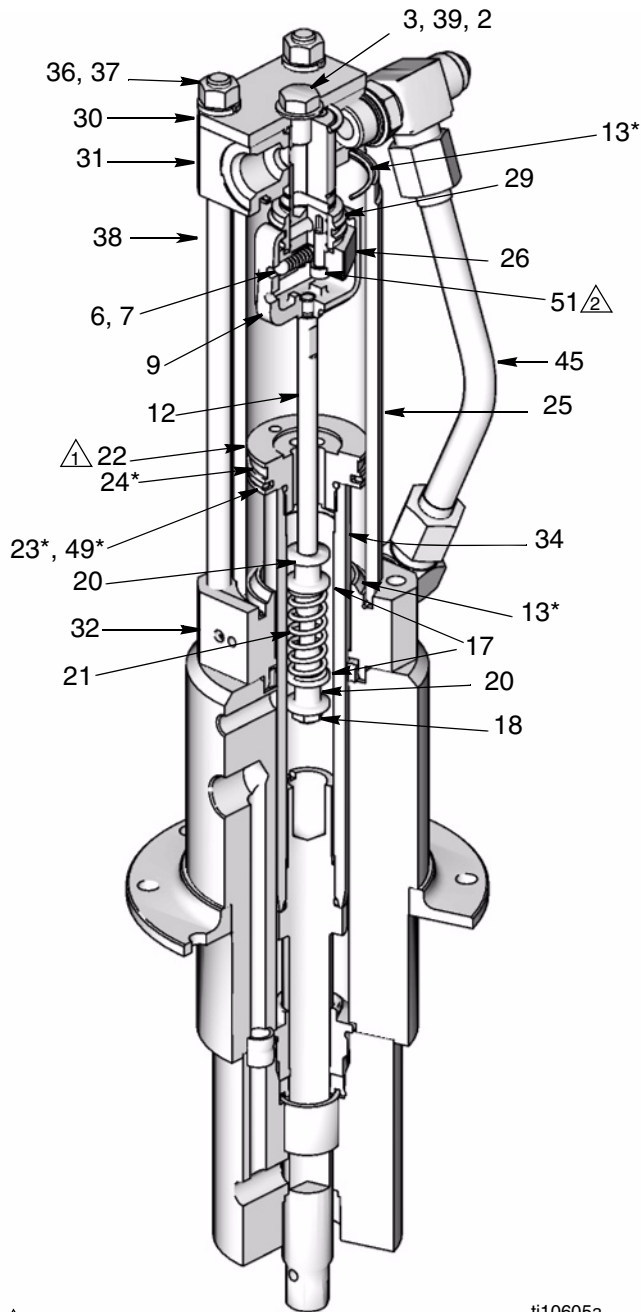

FIG. 7

See FIG. 7 for steps 1-3, except where noted.

1. Place adapter (43) in a vise. Remove four cap screws (46). Pull bottom cap (32) off adapter (43). If needed, replace seals as described on page 10.
2. Loosen both nuts on fluid tube (45). Use a wrench to rotate tube fittings (1, 60) to the side and then remove tube (45). Check o-rings (1a, 60a) on fittings and replace them if they are worn or damaged. Install plugs in fittings to prevent contamination. See FIG. 4 and Reciprocator Parts drawing, page 18.
3. Remove capscrew (3), nuts (36) and lockwashers (37) on top of reciprocator.



- 1 Torque to 40 to 48 ft-lbs (54 to 65 N.m)
- 2 Torque to 54 to 56 in-lbs (6.1 to 6.3 N.m)

ti10605a

FIG. 8

See FIG. 8 and Reciprocator Parts page 18 for steps 4-20, except where noted.

4. Tap bottom of displacement rod (34) with a plastic mallet to loosen cylinder (25).
5. Grasp valve spool (31) and pull it off cylinder and tie rods (38). Pull cylinder and piston off bottom cap (32). It is not necessary to remove tie rods from bottom cap.

6. Lay assembly on its side. Place a clean rag around yoke (9) to prevent losing detent balls. Slide yoke (9) sideways off valve sleeve (29) while holding the balls (7) and spring (6) in place.
7. Slide cylinder (25) off displacement rod (34). Hold hex end of displacement rod in a vise and use a spanner wrench in pin holes of the piston (22) to screw it off the rod.

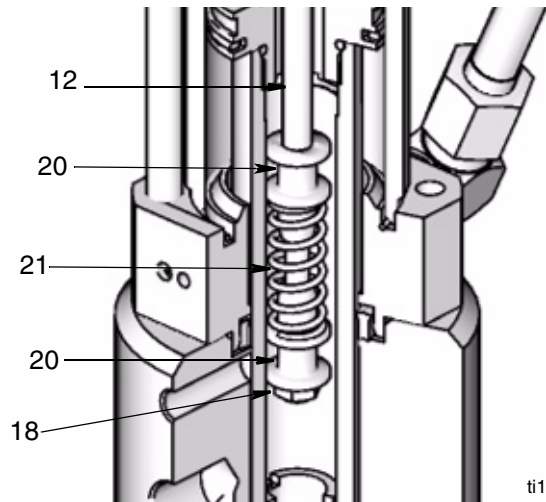

ti10605a

FIG. 9

8. (FIG. 9) Visually inspect the spring (21). If there is wear or damage, remove nut (18), spring (21) and retainers (20) from trip rod (12). Reassemble with a retainer (20) on each end of the new spring (21). You must thread nut onto rod until it runs out of thread, so that it bottoms out on rod's shoulder.



- If you are re-using or reassembling any parts, use a surface cleaner such as chlorinated solvent on the threads and blow with compressed air. A 1/4-28 UNF-2A tap can be used to remove adhesive from internal threads of yoke (9).
- Thread sealant and primer are required. See Reciprocator Repair Notes, page 12 for specifications. Loctite® 609 is used only in Step 9.

9. Apply fresh Loctite® 609 thread sealant to first two or three internal threads of yoke (9). Apply primer to external threads of rod (12). Let primer dry for 3-4 minutes. Assemble, torquing screw to 54-56 in-lbs (6.1 to 6.3 N.m). Remove excess sealant.

Allow 24 hours to cure before operating reciprocator.

- Clean all sealant from threads of any part you are reusing. Apply Loctite® 242 or Perma-Loc® 115 thread sealant to first two or three internal threads of valve assembly (31).

If you removed capscrew (51) apply thread sealant to first two or three internal threads of valve stop (26). Apply primer to external threads of valve sleeve (29). Let dry for three or four minutes. Assemble. Remove excess sealant.

 Allow 24 hours to cure before operating reciprocator.

- Remove o-ring (13*) from bottom of spool valve (31) and replace it with a new o-ring.
- Use a spanner wrench to screw piston (22) onto displacement rod (34). Torque to 40 to 48 ft-lb (54 to 65 N.m).

See FIG. 10 for steps 13-16.

- Lay Assembly A and Assembly B on work bench.
- Slide Assembly B in into center of tool (D), Part No. 189305. Align upper detent holes (C) of yoke (9) with center line of tool (D).
- Insert spring (6) and one ball (7) into valve stop (26) of Assembly A. Tilt valve stop and start guiding it into tool (D), making sure ball is sliding into rounded slot in tool (D). Place other ball at the other end of spring and push it in with your thumb while rotating valve stop (26) until spring is horizontal and balls are in place. Continue holding this assembly together.
- Slide valve stop assembly down into tool. Make sure balls (7) snap into upper set of holes (C) in yoke (9) and curved ends of guide clamp have engaged valve sleeve (29) groove. Slide tool (D) back over rod (12) to remove it.

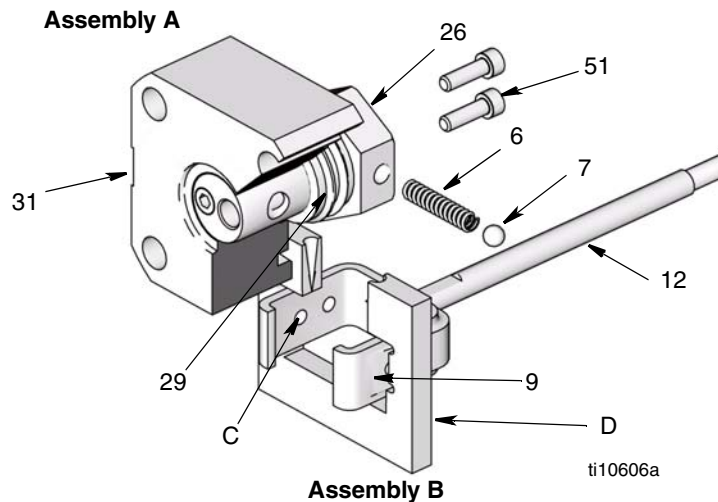

FIG. 10

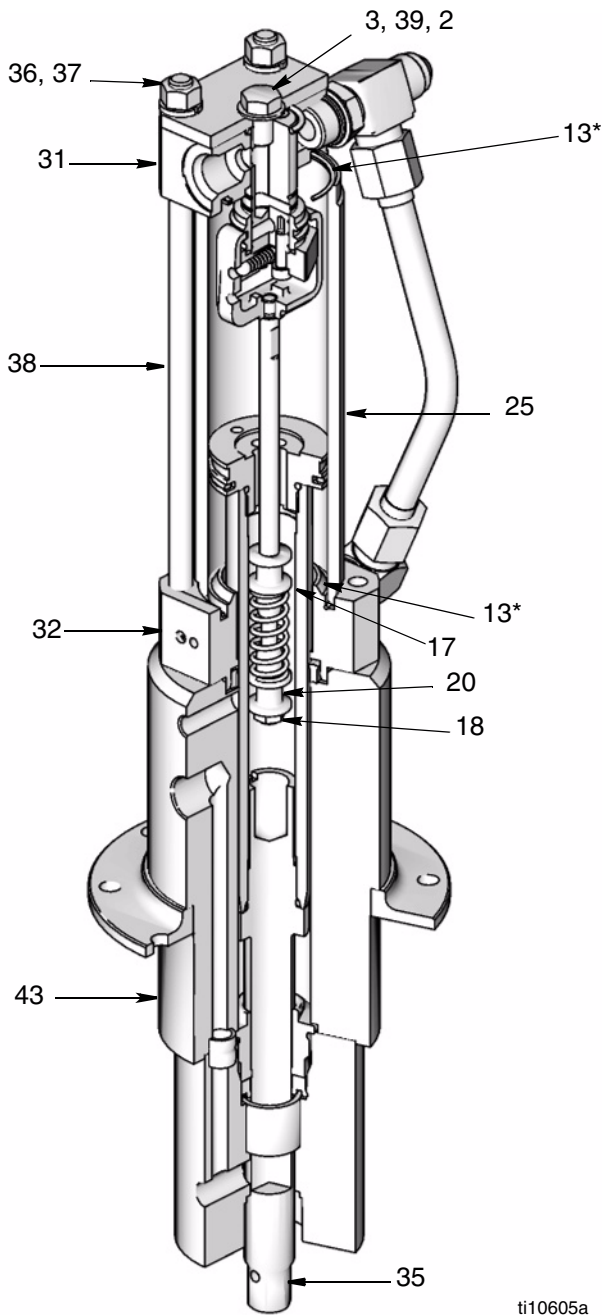



FIG. 11

ti10605a

See FIG. 11 for steps 17- 24 except where noted.

- 17. Place adapter (43) in a vise. Install seals as described on page 10. Install cylinder cap (32).
- 18. If tie rods (38) were removed, reinstall them with short threaded end up. The other end should be screwed about 9/16" into bottom cylinder cap (32).

 When reinstalling cylinder (25), Step 19, be sure port in valve spool (31) and port in the bottom cylinder cap (32) are in line with each other. Be sure o-rings (13*) are in place in valve spool and cylinder cap.

- 19. Place cylinder (25) on cylinder cap (32). Install piston (22) and valve assembly (31).
- 20. Install o-ring (49*) in deep, lower groove of piston (22). Install seal (23*) over o-ring. Install piston bearing (24*) around upper groove of piston. Holding piston bearing in place to avoid damage, slide cylinder over piston and press it down.
- 21. Install capscrew (3), o-ring (39) and washer (2). Install lockwashers (37) and nuts (36). Torque nuts to 28 to 32 ft-lb (38 to 43 N.m).
- 22. Reinstall fluid tube (45) and fittings (1). Torque fittings to 28 to 32 ft-lb (38 to 43 N.m). See Reciprocator Parts drawing, page 18.

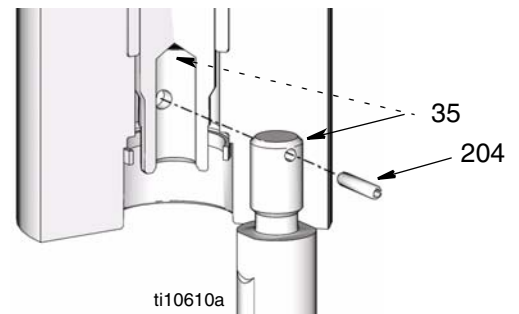

 Make sure the displacement rod (35) on the assembled reciprocator is exposed so the pump can be connected to it.



ti10610a

FIG. 12

- 23. To reconnect reciprocator and pump, install o-ring (17). Screw connecting rod (35) into displacement rod (34). Install cotter pin (204). Install a new gasket (202*). Push cylinder up into adapter and engage the threads. Screw in pump using a strap wrench for the final tightening (See FIG. 12 and Pump Parts, page 20).
- 24. Connect hydraulic supply and return hoses to fittings (5, 60).

					
<p>To reduce risk of static sparking, be sure to reconnect ground wire before operating pump.</p>					

Displacement Pump Repair

Disassembly

See FIG. 13 for steps 1-10, except where noted.



- Be sure you have all necessary parts on hand before you start. If using a repair kit, use all parts in the kit for the best results.
- Displacement Pump Repair Kit 241623 is available. Parts included in the kit are marked with a dagger (†) symbol in the parts drawing and list, page 20.

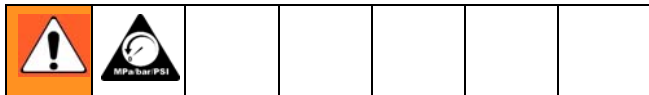

1. If possible, flush pump. **Relieve pressure**, page 7.
2. Follow instruction for **Disconnecting the Reciprocator and Displacement Pump**, page 11.

CAUTION
To avoid damaging shovel tube, do not use slots in tube to tighten or loosen tube.

3. Clamp pump in vise.
4. Use strap wrench to screw shovel tube (117) off pump cylinder (109).

5. Use wrench to screw shovel (116) off of shovel rod (108).
6. Use strap wrench on pump cylinder (109) to screw it out of extension tube (114). Screw tube connector (113) out of pump cylinder. Remove bearing (111†) and seal (112†).
7. Screw the shovel rod (108) out of the piston (101). Remove lower ball (106†). Screw piston out of extension rod (107). Remove upper ball (106†), retaining washer (103) and seal (104†).
8. Clean all the parts in a compatible solvent and inspect them for wear or damage. Use all parts in the repair kit, replace other parts as necessary.
9. Generously lubricate all parts with light, water-resistant grease and reassemble pump. See provided notes on FIG. 13 for torque values.

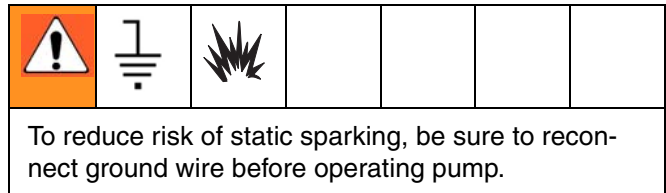

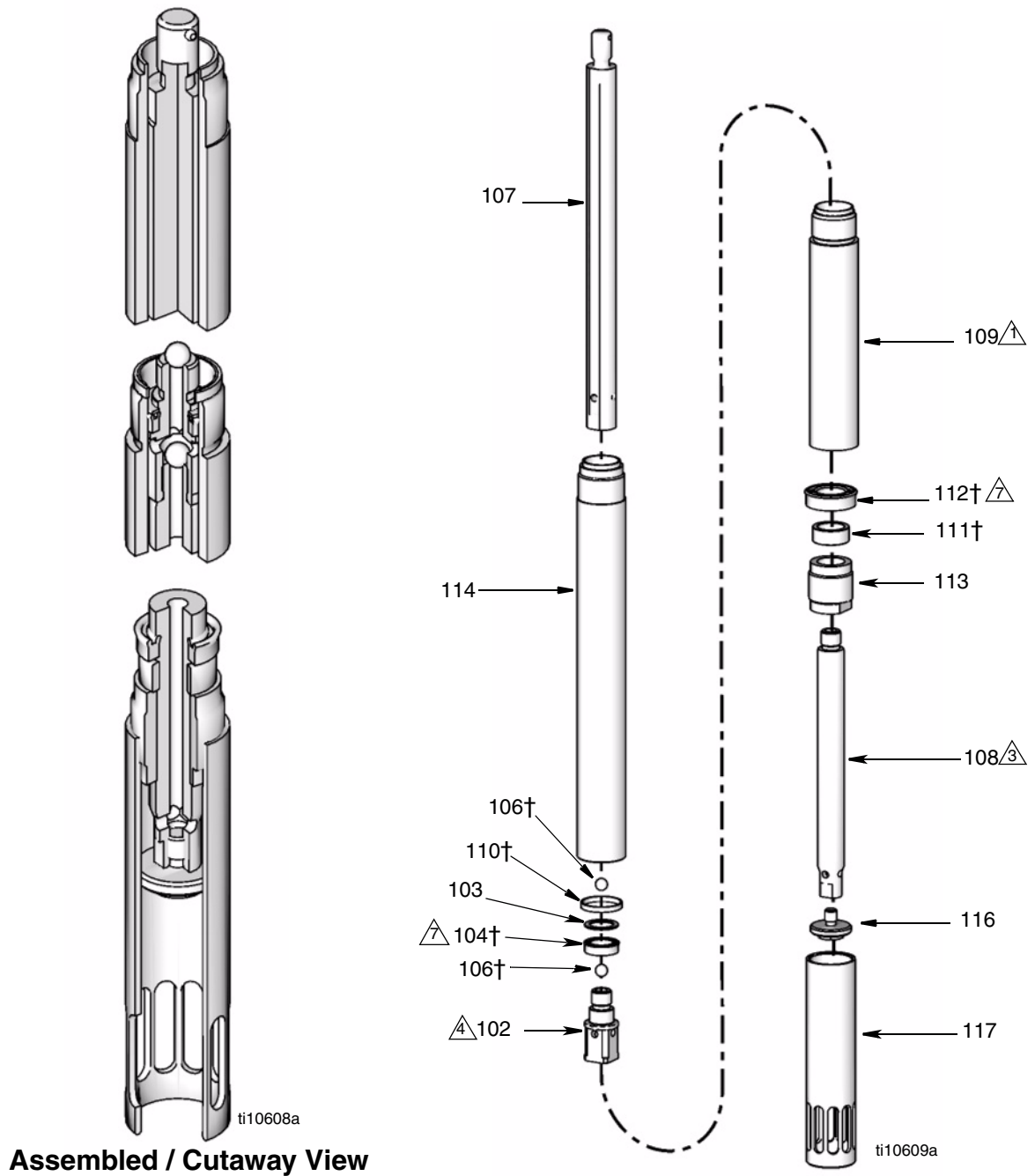

Assembled / Cutaway View

- △1 Using nut (113), torque the pump cylinder 109 to the extension tube (114) at 45 to 55 ft-lb (61 to 75 N.m).
- △3 Torque the shovel rod (108) to the piston (102) at 25 to 30 ft-lb (34 to 41 N.m).
- △4 Torque the piston (102) to the extension rod (107) at 25 to 30 ft-lb (34 to 41 N.m).
- △7 Assemble with lips facing up.

FIG. 13

Reciprocator Parts

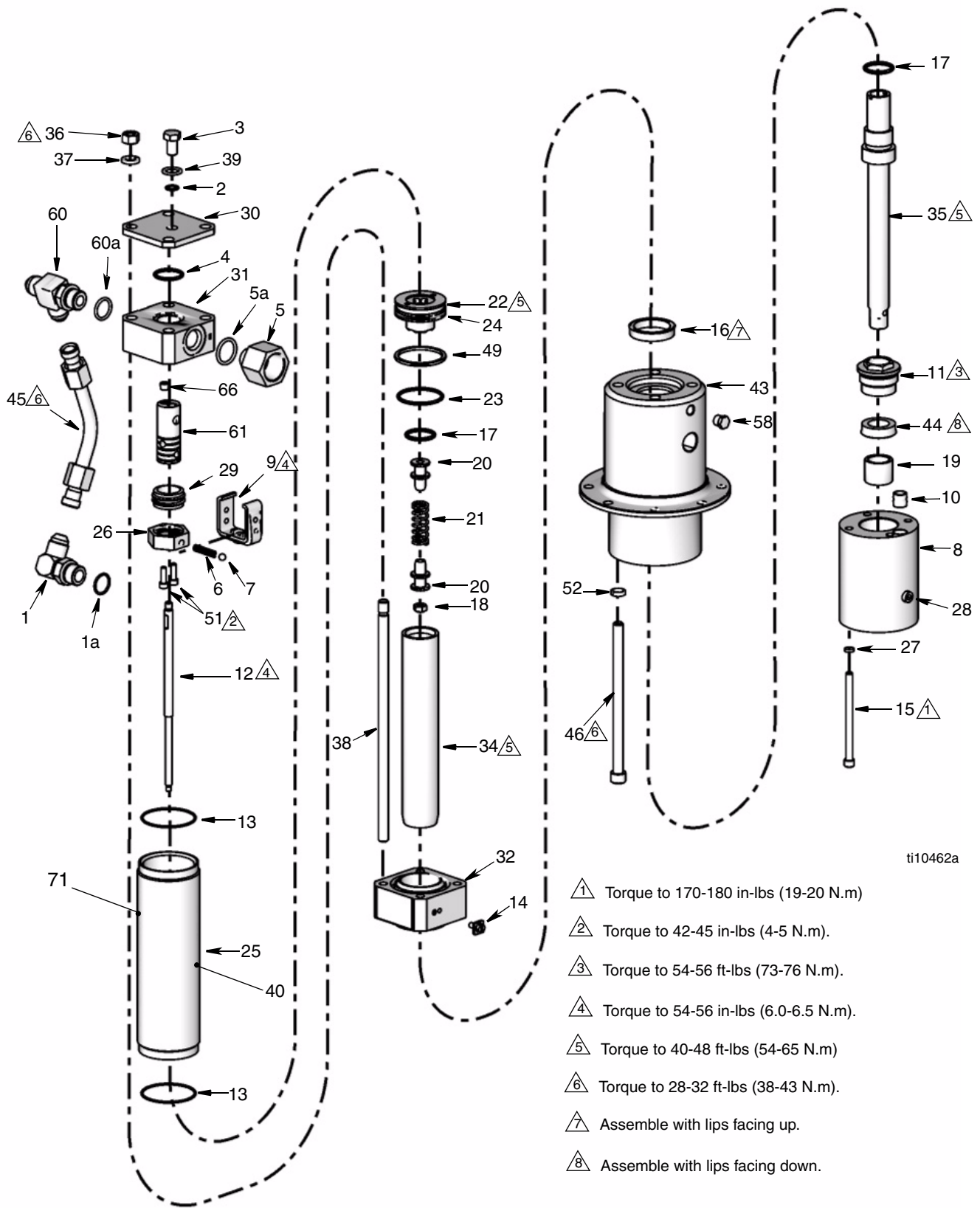

ti10462a

Reciprocator Parts

Ref. No.	Part No.	Description	Qty.	Ref. No.	Part No.	Description	Qty.
1	106470	ELBOW, straight thread, 3/4-16 unf-2a x 3/4-16 unf-2a, 37° flare includes item 1a	1	51	104092	CAPSCREW, sch; 10-24, unrc-3a x 5/8"	2
1a	110987	O-RING	1	52	106115	LOCKWASHER, spring, 3/8"	4
2	178179	WASHER, sealing	1	58	110064	PLUG, pipe, vented, 1/8-27 npt (f)	1
3	160276	CAPSCREW, hex hd, 3/8-24 x 5/8"	1	60	107197	TEE, includes item 60a	1
4*	104093	O-RING	1	60a	110987	O-RING	1
5	112568	ADAPTER, pip, 3/4 unf (m) 1/2 npt (f), steel, includes item 5a	1	61	192653	VALVE, spool	1
5a	110987	O-RING	1	66	103147	PLUG, pipe	1
6	108437	SPRING, compression, steel	1	71▲	189285	LABEL, hot surface	1
7	100069	BALL, 1/4" dia. steel	2	▲ Replacement Danger and Warning labels, tags, and cards are available at no cost.			
8		ADAPTER, pump	1	* These parts and items 202 on page 20 are included in Kit 247455 (purchase separately).			
9	189077	YOKE, valve	1	† These parts are included in Kit 241623 (purchase separately).			
10*		GASKET, seal	1	Assembly Tool 189305 required for repairing the reciprocator.			
11	192537	NUT, retainer	1				
12		ROD, trip	1				
13*	106274	O-RING, buna-N	2				
14	116343	SCREW, grounding	1				
15	113194	SCREW, cap, socket hd	2				
16*	108952	PACKING, v-block	1				
17	105765	O-RING	2				
18	114231	LOCKNUT, hex, 1/4-28 unf-3b steel and nylon	1				
19	193757	BEARING	1				
20		RETAINER, spring	2				
21	178189	SPRING, compression, steel	1				
22	192656	PISTON, cs	1				
23*	178226	SEAL, piston, glass-filled PTFE	1				
24*	178207	BEARING, piston, bronze-filled PTFE	1				
25	178229	CYLINDER, motor, cs	1				
26	192654	STOP, valve, cs	1				
27	105510	WASHER, lock, spring	1				
28	100139	PLUG, pipe	1				
29	189072	SLEEVE, valve, steel	1				
30	178181	PLATE, cap	1				
31	187176	CAP, cylinder, top	1				
32	186225	CAP, cylinder, bottom	1				
34	188078	ROD, displacement	1				
35		ROD, displacement	1				
36	100307	NUT, full, hex; 3/8-16 unc-2b	4				
37	100133	LOCKWASHER, 3/8"	4				
38	187405	ROD, tie, 8.5" shoulder to shoulder, 3/8-16 unc-2a, cs	4				
39	155685	O-RING	1				
40▲	179885	LABEL, Warning	1				
43		HOUSING, motor	1				
44*†	114179	PACKING, u-cup	1				
45	217221	TUBE, inlet	1				
46	120557	CAPSCREW, sch, 3/18-16 unc-2a x 4.5"	4				
49*	108014	PACKING, o-ring	1				
				102	196184	PISTON, 50:1	1
				103	196185	WASHER, retainer	1
				104†	114171	PACKING, u-cup	1
				106†	100065	BALL	1
				107	15R104	ROD, connecting, model 247540	1
					15M382	ROD, connecting, model 247443	1
					15M445	ROD, connecting, model 247450	1
				108	192540	ROD, shovel, 50:1	1
				109	192538	CYLINDER, pump, 50:1	1
				110†	192533	GASKET, seal	1
				111†	192534	BEARING	1
				112†	114178	PACKING, u-cup	1
				113	192531	RETAINER, seal	1
				114	15R103	TUBE, spacer, model 247540	1
					15M381	TUBE, spacer, model 247443	1
					15M444	TUBE, spacer, model 247450	1
				116	192660	PISTON, shovel, 50:1	1
				117	192539	TUBE, shovel	1
				† These parts are included in Kit 241623 (purchase separately).			

Displacement Pump Parts

See FIG. 13, page 17.

Model 247540, 60# Automatic Lube Pump

Module Length

Model 247443, 120# Drum Length

Model 247450, 400# Drum Length

Ref. No.	Part No.	Description	Qty.
	102	196184 PISTON, 50:1	1
	103	196185 WASHER, retainer	1
	104†	114171 PACKING, u-cup	1
	106†	100065 BALL	1
	107	15R104 ROD, connecting, model 247540	1
		15M382 ROD, connecting, model 247443	1
		15M445 ROD, connecting, model 247450	1
	108	192540 ROD, shovel, 50:1	1
	109	192538 CYLINDER, pump, 50:1	1
	110†	192533 GASKET, seal	1
	111†	192534 BEARING	1
	112†	114178 PACKING, u-cup	1
	113	192531 RETAINER, seal	1
	114	15R103 TUBE, spacer, model 247540	1
		15M381 TUBE, spacer, model 247443	1
		15M444 TUBE, spacer, model 247450	1
	116	192660 PISTON, shovel, 50:1	1
	117	192539 TUBE, shovel	1

† These parts are included in Kit 241623 (purchase separately).

Pump Parts

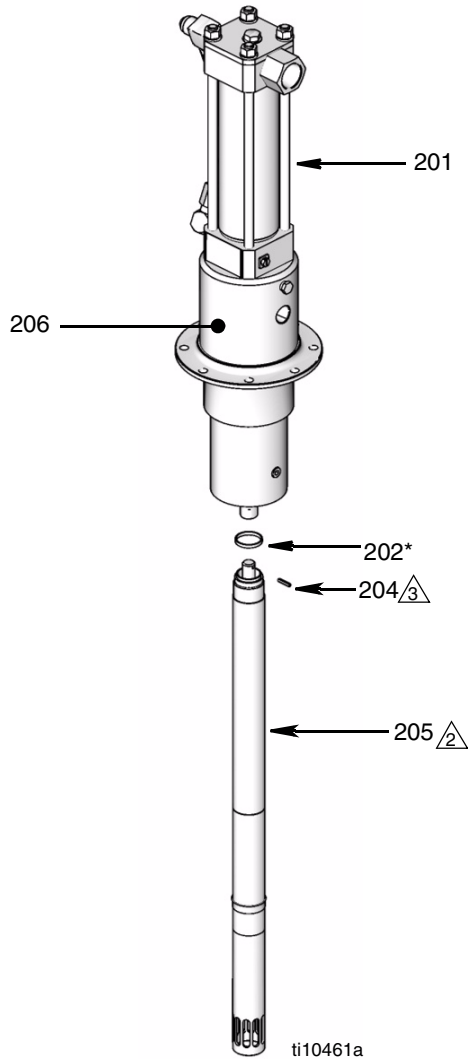

Model 247540

60# Automatic Lube Pump Module Length

Ref	No.	Part No.	Description	Qty
	201		RECIPROCATOR, page 18	1
	202*	192533	SEAL, gasket	1
	204	112154	PIN	1
	205		DISPLACEMENT PUMP	1
	206▲	183741	LABEL, identification	1

Model 247443

120# Drum Length

Ref	No.	Part No.	Description	Qty
	201		RECIPROCATOR, page 18	1
	202*	192533	SEAL, gasket	1
	204	112154	PIN	1
	205		DISPLACEMENT PUMP	1
	206▲	183741	LABEL, identification	1

Model 247450

400# Drum Length

Ref	No.	Part No.	Description	Qty
	201		RECIPROCATOR, page 18	1
	202*	192533	SEAL, gasket	1
	204	112154	PIN	1
	205		DISPLACEMENT PUMP	1
	206▲	183741	LABEL, identification	1

▲ Replacement Danger and Warning labels, tags, and cards are available at no cost.

* These parts are included in Kit 247455 (purchase separately). See page 18 for other parts included in this kit.

△ Apply thread lubricant, Part No. 070268 to threads and torque to 45-55 ft. lbs (61.0 to 74.5 N.m)

△ Coupling joint should have free play after pin (204) is installed

Technical Data

Max grease output pressure.....	7500 psi (51 MPa, 517 bar)
Max hydraulic fluid input pressure.....	600 psi (4.1 MPa, 41 bar)
Max hydraulic fluid input volume	3 gpm (11.7 lpm), 60 cpm
Hydraulic fluid consumption rate.....	6.5 ounces (0.195 liter) per cycle or 1 gallon per 19.5 cycles
Maximum fluid temperature.....	250°F (121°C)
Output per cycle.....	0.6 in ³ /cycle
Maximum flow rate.....	1.1 lbs/min @ 60 cycles/min
Stroke.....	3 in. (76.2 mm)
Displacement pump wetted parts.....	steel, polyurethane, acetal, buna-N, polyester elastomer
Hydraulic reciprocator wetted parts.....	steel, buna-N rubber, glass and bronze filled PTFE, nylon, polyurethane
Weight.....	Model 247443: 43.5 lb (19.7 kg) Model 247450: 48 lb (21.8 kg) Model 247540: 41 lb (18.6 kg)

Typical Fluid Outlet Pressure

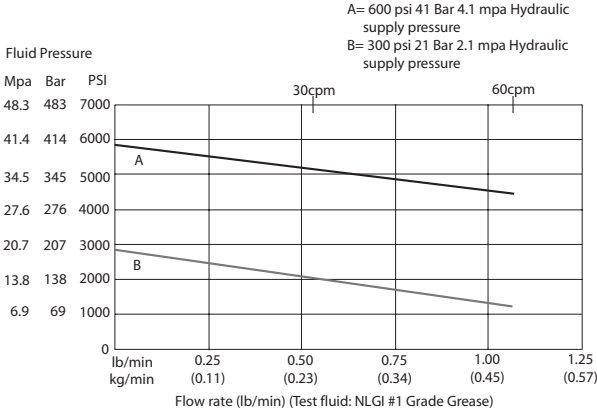

Dimensions and Mounting Hole Layout

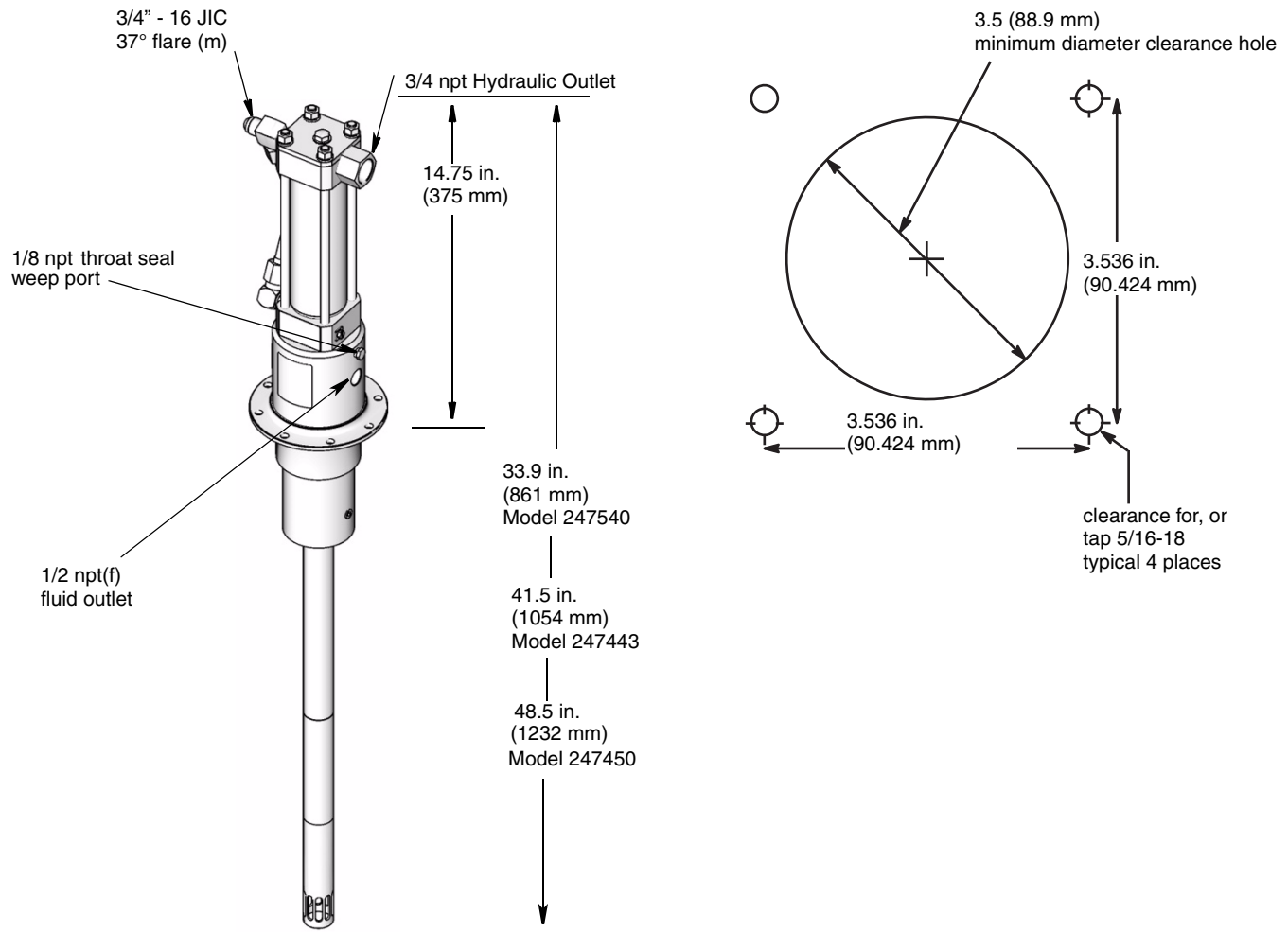

Graco Standard Warranty

Graco warrants all equipment referenced in this document which is manufactured by Graco and bearing its name to be free from defects in material and workmanship on the date of sale to the original purchaser for use. With the exception of any special, extended, or limited warranty published by Graco, Graco will, for a period of twelve months from the date of sale, repair or replace any part of the equipment determined by Graco to be defective. This warranty applies only when the equipment is installed, operated and maintained in accordance with Graco's written recommendations.

This warranty does not cover, and Graco shall not be liable for general wear and tear, or any malfunction, damage or wear caused by faulty installation, misapplication, abrasion, corrosion, inadequate or improper maintenance, negligence, accident, tampering, or substitution of non-Graco component parts. Nor shall Graco be liable for malfunction, damage or wear caused by the incompatibility of Graco equipment with structures, accessories, equipment or materials not supplied by Graco, or the improper design, manufacture, installation, operation or maintenance of structures, accessories, equipment or materials not supplied by Graco.

This warranty is conditioned upon the prepaid return of the equipment claimed to be defective to an authorized Graco distributor for verification of the claimed defect. If the claimed defect is verified, Graco will repair or replace free of charge any defective parts. The equipment will be returned to the original purchaser transportation prepaid. If inspection of the equipment does not disclose any defect in material or workmanship, repairs will be made at a reasonable charge, which charges may include the costs of parts, labor, and transportation.

THIS WARRANTY IS EXCLUSIVE, AND IS IN LIEU OF ANY OTHER WARRANTIES, EXPRESS OR IMPLIED, INCLUDING BUT NOT LIMITED TO WARRANTY OF MERCHANTABILITY OR WARRANTY OF FITNESS FOR A PARTICULAR PURPOSE.

Graco's sole obligation and buyer's sole remedy for any breach of warranty shall be as set forth above. The buyer agrees that no other remedy (including, but not limited to, incidental or consequential damages for lost profits, lost sales, injury to person or property, or any other incidental or consequential loss) shall be available. Any action for breach of warranty must be brought within two (2) years of the date of sale.

GRACO MAKES NO WARRANTY, AND DISCLAIMS ALL IMPLIED WARRANTIES OF MERCHANTABILITY AND FITNESS FOR A PARTICULAR PURPOSE, IN CONNECTION WITH ACCESSORIES, EQUIPMENT, MATERIALS OR COMPONENTS SOLD BUT NOT MANUFACTURED BY GRACO. These items sold, but not manufactured by Graco (such as electric motors, switches, hose, etc.), are subject to the warranty, if any, of their manufacturer. Graco will provide purchaser with reasonable assistance in making any claim for breach of these warranties.

In no event will Graco be liable for indirect, incidental, special or consequential damages resulting from Graco supplying equipment hereunder, or the furnishing, performance, or use of any products or other goods sold hereto, whether due to a breach of contract, breach of warranty, the negligence of Graco, or otherwise.

FOR GRACO CANADA CUSTOMERS

The Parties acknowledge that they have required that the present document, as well as all documents, notices and legal proceedings entered into, given or instituted pursuant hereto or relating directly or indirectly hereto, be drawn up in English. Les parties reconnaissent avoir convenu que la rédaction du présente document sera en Anglais, ainsi que tous documents, avis et procédures judiciaires exécutés, donnés ou intentés, à la suite de ou en rapport, directement ou indirectement, avec les procédures concernées.

Graco Information

To place an order, contact your Graco distributor or to identify the nearest distributor call:
612-623-6928 or Toll Free: 1-800-533-9655; Fax 612-378-3590

*All written and visual data contained in this document reflects the latest product information available at the time of publication.
Graco reserves the right to make changes at any time without notice.*

This manual contains English. MM 312350

Graco Headquarters: Minneapolis

International Offices: Belgium, China, Japan, Korea

GRACO INC. P.O. BOX 1441 MINNEAPOLIS, MN 55440-1441

Copyright 2007, Graco Inc. is registered to I.S. EN ISO 9001

www.graco.com

Revised 2/2008